

Eyal Buks

Quantum Mechanics - Lecture Notes

May 2, 2024

Springer-Verlag

Berlin Heidelberg New York

London Paris Tokyo

Hong Kong Barcelona

Budapest

Contents

0.1	Preface	1
1.	Hamilton's Formalism of Classical Physics	3
1.1	Action and Lagrangian	3
1.2	Principle of Least Action	4
1.3	Hamiltonian	7
1.4	Poisson's Brackets	9
1.5	Problems	10
1.6	Solutions	11
2.	State Vectors and Operators	19
2.1	Linear Vector Space	19
2.2	Operators	21
2.3	Dirac's notation	21
2.4	Dual Correspondence	22
2.5	Matrix Representation	24
2.6	Observables	26
2.6.1	Hermitian Adjoint	26
2.6.2	Eigenvalues and Eigenvectors	27
2.7	Quantum Measurement	32
2.8	Example - Spin 1/2	33
2.9	Unitary Operators	37
2.10	Trace	38
2.11	Commutation Relation	39
2.12	Simultaneous Diagonalization of Commuting Operators	40
2.13	Uncertainty Principle	41
2.14	Problems	42
2.15	Solutions	45
3.	The Position and Momentum Observables	57
3.1	The One-Dimensional Case	57
3.1.1	Position Representation	58
3.1.2	Momentum Representation	62
3.2	Transformation Function	63
3.3	Generalization for 3D	65

3.4	Problems	66
3.5	Solutions	68
4.	Quantum Dynamics	79
4.1	Time Evolution Operator	79
4.2	Time Independent Hamiltonian	80
4.3	Example - Spin 1/2	81
4.4	Connection to Classical Dynamics	83
4.5	Symmetric Ordering	84
4.6	Problems	86
4.7	Solutions	95
5.	The Harmonic Oscillator	127
5.1	Eigenstates	128
5.2	Coherent States	130
5.3	Problems	133
5.4	Solutions	142
6.	Angular Momentum	179
6.1	Angular Momentum and Rotation	180
6.2	General Angular Momentum	182
6.3	Simultaneous Diagonalization of \mathbf{J}^2 and J_z	182
6.4	Example - Spin 1/2	187
6.5	Orbital Angular Momentum	187
6.6	Problems	193
6.7	Solutions	210
7.	Central Potential	267
7.1	Simultaneous Diagonalization of the Operators \mathcal{H} , \mathbf{L}^2 and L_z	268
7.2	The Radial Equation	270
7.3	Hydrogen Atom	272
7.4	Problems	278
7.5	Solutions	282
8.	Density Operator	297
8.1	Pure and mixed states	299
8.2	Time Evolution	300
8.3	Quantum Statistical Mechanics	300
8.4	Problems	301
8.5	Solutions	325
9.	Time Independent Perturbation Theory	421
9.1	The Level E_n	422
9.1.1	Nondegenerate Case	423
9.1.2	Degenerate Case	425

9.2	Example	426
9.3	Problems	428
9.4	Solutions	437
10.	Time-Dependent Perturbation Theory	479
10.1	Time Evolution	479
10.2	Perturbation Expansion	480
10.3	Transition Probability	482
10.3.1	The Stationary Case	484
10.3.2	The Near-Resonance Case	486
10.3.3	\mathcal{H}_1 is Separable	487
10.4	Problems	487
10.5	Solutions	492
11.	WKB Approximation	509
11.1	WKB Wavefunction	509
11.2	Turning Point	512
11.3	Bohr-Sommerfeld Quantization Rule	516
11.4	Tunneling	518
11.5	Problems	519
11.6	Solutions	521
12.	Path Integration	535
12.1	Charged Particle in Electromagnetic Field	535
12.2	Classical Limit	539
12.3	Aharonov-Bohm Effect	540
12.3.1	Two-slit Interference	542
12.3.2	Gauge Invariance	543
12.4	One-Dimensional Path Integrals	545
12.4.1	One-Dimensional Free Particle	546
12.4.2	Expansion Around the Classical Path	547
12.4.3	One-Dimensional Harmonic Oscillator	549
12.5	Semiclassical Limit	553
12.6	Problems	554
12.7	Solutions	556
13.	Adiabatic Approximation	567
13.1	Momentary Diagonalization	567
13.2	Gauge Transformation	569
13.3	Adiabatic Limit	569
13.4	The Case of Two-Dimensional Hilbert Space	570
13.5	Transition Probability	572
13.5.1	The Case of Two-Dimensional Hilbert Space	573
13.6	Slow and Fast Coordinates	576
13.7	Problems	579

13.8 Solutions	581
14. The Quantized Electromagnetic Field	591
14.1 Classical Electromagnetic Cavity	591
14.2 Quantum Electromagnetic Cavity	597
14.3 Periodic Boundary Conditions	598
14.4 The Poincaré sphere	600
14.4.1 Colinear birefringence	602
14.4.2 Circular birefringence	603
14.4.3 Polarizer	603
14.4.4 Mirror	604
14.4.5 Time reversal symmetry	604
14.4.6 Reverse propagation	604
14.5 Problems	606
14.6 Solutions	609
15. Light Matter Interaction	625
15.1 Hamiltonian	625
15.2 Transition Rates	626
15.2.1 Spontaneous Emission	626
15.2.2 Stimulated Emission and Absorption	627
15.2.3 Selection Rules	628
15.3 Semiclassical Case	630
15.4 Problems	633
15.5 Solutions	635
16. Identical Particles	647
16.1 Basis for the Hilbert Space	647
16.2 Bosons	650
16.3 Fermions	651
16.4 Changing the Basis	653
16.5 Many Particle Observables	655
16.5.1 One-Particle Observables	655
16.5.2 Two-Particle Observables	656
16.6 Hamiltonian	658
16.7 Momentum Representation	661
16.8 Spin	663
16.9 The Electron Gas	663
16.10 Problems	665
16.11 Solutions	669

17. Open Quantum Systems	693
17.1 Classical Resonator	693
17.2 Quantum Resonator Coupled to Thermal Bath	694
17.2.1 The closed System	694
17.2.2 Coupling to Thermal Bath	695
17.2.3 Thermal Equilibrium	698
17.3 Two Level System Coupled to Thermal Bath	701
17.3.1 The Closed System	701
17.3.2 Coupling to Thermal Baths	702
17.3.3 Thermal Equilibrium	706
17.3.4 Correlation Functions	707
17.3.5 The Bloch Equations	709
17.4 Problems	711
17.5 Solutions	724
18. Superconductivity	757
18.1 Macroscopic Wavefunction	757
18.1.1 Single Particle in Electromagnetic Field	757
18.1.2 The Macroscopic Quantum Model	759
18.1.3 London Equations	759
18.2 The Josephson Effect	763
18.2.1 Two-State Model	763
18.2.2 The First Josephson Relation	764
18.2.3 The Second Josephson Relation	764
18.2.4 The Energy of a Josephson Junction	765
18.2.5 Gauge Invariant Phase	765
18.3 RF SQUID	766
18.3.1 Lagrangian	767
18.3.2 Readout with LC Resonator	769
18.3.3 Hamiltonian	775
18.3.4 Flux Quantum Bit	776
18.3.5 Superconducting Cavity Quantum Electrodynamics	778
18.3.6 Damping	783
18.4 Circuit graph representation	784
18.4.1 Lagrangian	785
18.4.2 DC SQUID	786
18.5 Dielectric Response	789
18.5.1 Dielectric Function	789
18.5.2 Two-Fluid Model	794
18.5.3 Phonon Mediated Electron-Electron Interaction	795
18.6 BCS Model	797
18.6.1 The Hamiltonian	797
18.6.2 Bogoliubov Transformation	798
18.6.3 The Energy Gap	802
18.6.4 The Ground State	804

Contents

18.6.5 Pairing Wavefunction	806
18.7 The Josephson Effect	807
18.7.1 The Second Josephson Relation	809
18.7.2 The Energy of a Josephson Junction	810
18.7.3 The First Josephson Relation	813
18.8 Problems	814
18.9 Solutions	832
References	871
Index	873

0.1 Preface

The dynamics of a quantum system is governed by the celebrated Schrödinger equation

$$i\hbar \frac{d}{dt} |\psi\rangle = \mathcal{H} |\psi\rangle , \quad (0.1)$$

where $i = \sqrt{-1}$ and $\hbar = 1.05457266 \times 10^{-34}$ J s is Planck's h-bar constant. However, what is the meaning of the symbols $|\psi\rangle$ and \mathcal{H} ? The answers will be given in the first part of the course (chapters 1-4), which reviews several physical and mathematical concepts that are needed to formulate the theory of quantum mechanics. We will learn that $|\psi\rangle$ in Eq. (0.1) represents the ket-vector state of the system and \mathcal{H} represents the Hamiltonian operator. The operator \mathcal{H} is directly related to the Hamiltonian function in classical physics, which will be defined in the first chapter. The ket-vector state and its physical meaning will be introduced in the second chapter. Chapter 3 reviews the position and momentum operators, whereas chapter 4 discusses dynamics of quantum systems. The second part of the course (chapters 5-7) is devoted to some relatively simple quantum systems including a harmonic oscillator, spin, hydrogen atom and more. In chapter 8 we will study quantum systems in thermal equilibrium. The third part of the course (chapters 9-13) is devoted to approximation methods such as perturbation theory, semiclassical and adiabatic approximations. Light and its interaction with matter are the subjects of chapter 14-15. Finally, systems of identical particles will be discussed in chapter 16 and open quantum systems in chapter 17. Most of the material in these lecture notes is based on the textbooks [1, 2, 3, 4, 6, 7].

1. Hamilton's Formalism of Classical Physics

In this chapter the Hamilton's formalism of classical physics is introduced, with a special emphasis on the concepts that are needed for quantum mechanics.

1.1 Action and Lagrangian

Consider a classical physical system having N degrees of freedom. The classical state of the system can be described by N independent coordinates q_n , where $n = 1, 2, \dots, N$. The vector of coordinates is denoted by

$$Q = (q_1, q_2, \dots, q_N) . \quad (1.1)$$

Consider the case where the vector of coordinates takes the value Q_1 at time t_1 and the value Q_2 at a later time $t_2 > t_1$, namely

$$Q(t_1) = Q_1 , \quad (1.2)$$

$$Q(t_2) = Q_2 . \quad (1.3)$$

The *action* S associated with the evolution of the system from time t_1 to time t_2 is defined by

$$S = \int_{t_1}^{t_2} dt \mathcal{L} , \quad (1.4)$$

where \mathcal{L} is the Lagrangian function of the system. In general, the Lagrangian is a function of the coordinates Q , the velocities \dot{Q} and time t , namely

$$\mathcal{L} = \mathcal{L}(Q, \dot{Q}; t) , \quad (1.5)$$

where

$$\dot{Q} = (\dot{q}_1, \dot{q}_2, \dots, \dot{q}_N) , \quad (1.6)$$

and where overdot denotes time derivative. The time evolution of Q , in turn, depends on the trajectory taken by the system from point Q_1 at time t_1

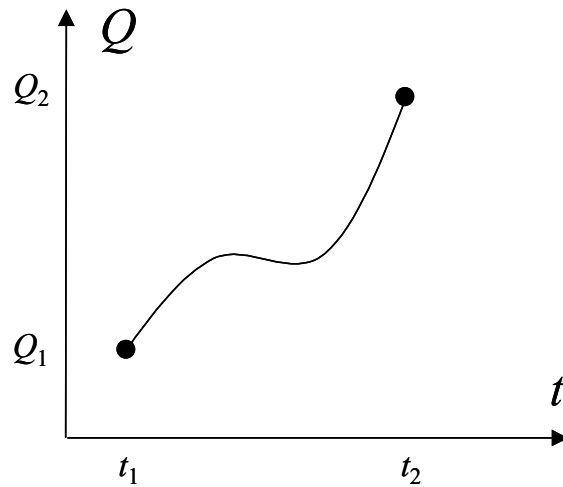

Fig. 1.1. A trajectory taken by the system from point Q_1 at time t_1 to point Q_2 at time t_2 .

to point Q_2 at time t_2 (see Fig. 1.1). For a given trajectory Γ the time dependency is denoted as

$$Q(t) = Q_\Gamma(t) . \quad (1.7)$$

1.2 Principle of Least Action

For any given trajectory $Q(t)$ the action can be evaluated using Eq. (1.4). Consider a classical system evolving in time from point Q_1 at time t_1 to point Q_2 at time t_2 along the trajectory $Q_\Gamma(t)$. The trajectory $Q_\Gamma(t)$, which is obtained from the laws of classical physics, has the following unique property known as the principle of least action:

Proposition 1.2.1 (principle of least action). *Among all possible trajectories from point Q_1 at time t_1 to point Q_2 at time t_2 the action obtains its minimal value by the classical trajectory $Q_\Gamma(t)$.*

In a weaker version of this principle, the action obtains a local minimum for the trajectory $Q_\Gamma(t)$. As the following theorem shows, the principle of least action leads to a set of equations of motion, known as Euler-Lagrange equations.

Theorem 1.2.1. *The classical trajectory $Q_\Gamma(t)$, for which the action obtains its minimum value, obeys the Euler-Lagrange equations of motion, which are given by*

$$\frac{d}{dt} \frac{\partial \mathcal{L}}{\partial \dot{q}_n} = \frac{\partial \mathcal{L}}{\partial q_n}, \quad (1.8)$$

where $n = 1, 2, \dots, N$.

Proof. Consider another trajectory $Q_{\Gamma'}(t)$ from point Q_1 at time t_1 to point Q_2 at time t_2 (see Fig. 1.2). The difference

$$\delta Q = Q_{\Gamma'}(t) - Q_{\Gamma}(t) = (\delta q_1, \delta q_2, \dots, \delta q_N) \quad (1.9)$$

is assumed to be infinitesimally small. To lowest order in δQ the change in the action δS is given by

$$\begin{aligned} \delta S &= \int_{t_1}^{t_2} dt \delta \mathcal{L} \\ &= \int_{t_1}^{t_2} dt \left[\sum_{n=1}^N \frac{\partial \mathcal{L}}{\partial q_n} \delta q_n + \sum_{n=1}^N \frac{\partial \mathcal{L}}{\partial \dot{q}_n} \delta \dot{q}_n \right] \\ &= \int_{t_1}^{t_2} dt \left[\sum_{n=1}^N \frac{\partial \mathcal{L}}{\partial q_n} \delta q_n + \sum_{n=1}^N \frac{\partial \mathcal{L}}{\partial \dot{q}_n} \frac{d}{dt} \delta q_n \right]. \end{aligned} \quad (1.10)$$

Integrating the second term by parts leads to

$$\begin{aligned} \delta S &= \int_{t_1}^{t_2} dt \sum_{n=1}^N \left(\frac{\partial \mathcal{L}}{\partial q_n} - \frac{d}{dt} \frac{\partial \mathcal{L}}{\partial \dot{q}_n} \right) \delta q_n \\ &\quad + \sum_{n=1}^N \left[\frac{\partial \mathcal{L}}{\partial \dot{q}_n} \delta q_n \right]_{t_1}^{t_2}. \end{aligned} \quad (1.11)$$

The last term vanishes since

$$\delta Q(t_1) = \delta Q(t_2) = 0. \quad (1.12)$$

The principle of least action implies that

$$\delta S = 0. \quad (1.13)$$

This has to be satisfied for *any* δQ , therefore the following must hold

$$\frac{d}{dt} \frac{\partial \mathcal{L}}{\partial \dot{q}_n} = \frac{\partial \mathcal{L}}{\partial q_n}. \quad (1.14)$$

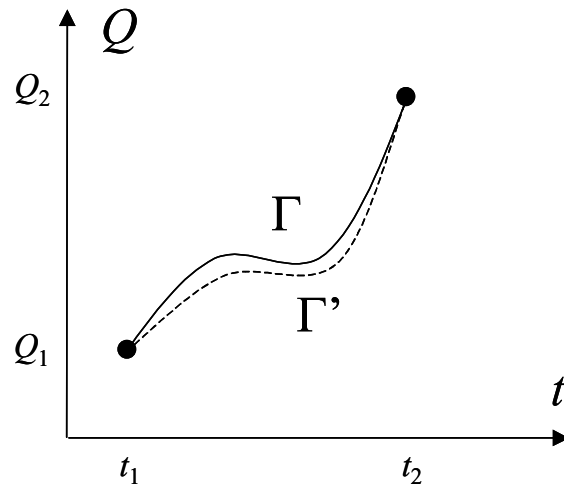

Fig. 1.2. The classical trajectory $Q_{\Gamma}(t)$ and the trajectory $Q_{\Gamma'}(t)$.

In what follows we will assume for simplicity that the kinetic energy T of the system can be expressed as a function of the velocities \dot{Q} only (namely, it does not explicitly depend on the coordinates Q). The components of the generalized force F_n , where $n = 1, 2, \dots, N$, are derived from the potential energy U of the system as follows

$$F_n = -\frac{\partial U}{\partial q_n} + \frac{d}{dt} \frac{\partial U}{\partial \dot{q}_n} . \quad (1.15)$$

When the potential energy can be expressed as a function of the coordinates Q only (namely, when it is independent on the velocities \dot{Q}), the system is said to be *conservative*. For that case, the Lagrangian can be expressed in terms of T and U as

$$\mathcal{L} = T - U . \quad (1.16)$$

Example 1.2.1. Consider a point particle having mass m moving in a one-dimensional potential $U(x)$. The Lagrangian is given by

$$\mathcal{L} = T - U = \frac{m\dot{x}^2}{2} - U(x) . \quad (1.17)$$

From the Euler-Lagrange equation

$$\frac{d}{dt} \frac{\partial \mathcal{L}}{\partial \dot{x}} = \frac{\partial \mathcal{L}}{\partial x} , \quad (1.18)$$

one finds that

$$m\ddot{x} = -\frac{\partial U}{\partial x} . \quad (1.19)$$

1.3 Hamiltonian

The set of Euler-Lagrange equations contains N second order differential equations. In this section we derive an alternative and equivalent set of equations of motion, known as Hamilton-Jacobi equations, that contains twice the number of equations, namely $2N$, however, of first, instead of second, order.

Definition 1.3.1. *The variable canonically conjugate to q_n is defined by*

$$p_n = \frac{\partial \mathcal{L}}{\partial \dot{q}_n} . \quad (1.20)$$

Definition 1.3.2. *The Hamiltonian of a physical system is a function of the vector of coordinates Q , the vector of canonical conjugate variables $P = (p_1, p_2, \dots, p_N)$ and time, namely*

$$\mathcal{H} = \mathcal{H}(Q, P; t) , \quad (1.21)$$

is defined by

$$\mathcal{H} = \sum_{n=1}^N p_n \dot{q}_n - \mathcal{L} , \quad (1.22)$$

where \mathcal{L} is the Lagrangian.

Theorem 1.3.1. *The classical trajectory satisfies the Hamilton-Jacobi equations of motion, which are given by*

$$\dot{q}_n = \frac{\partial \mathcal{H}}{\partial p_n} , \quad (1.23)$$

$$\dot{p}_n = - \frac{\partial \mathcal{H}}{\partial q_n} , \quad (1.24)$$

where $n = 1, 2, \dots, N$.

Proof. The differential of \mathcal{H} is given by

$$\begin{aligned} d\mathcal{H} &= d \sum_{n=1}^N p_n \dot{q}_n - d\mathcal{L} \\ &= \sum_{n=1}^N \left(\dot{q}_n dp_n + p_n d\dot{q}_n - \underbrace{\frac{\partial \mathcal{L}}{\partial q_n}}_{\frac{d}{dt} \frac{\partial \mathcal{L}}{\partial \dot{q}_n}} dq_n - \underbrace{\frac{\partial \mathcal{L}}{\partial \dot{q}_n}}_{p_n} d\dot{q}_n \right) - \frac{\partial \mathcal{L}}{\partial t} dt \\ &= \sum_{n=1}^N (\dot{q}_n dp_n - \dot{p}_n dq_n) - \frac{\partial \mathcal{L}}{\partial t} dt . \end{aligned} \quad (1.25)$$

Thus the following holds

$$\dot{q}_n = \frac{\partial \mathcal{H}}{\partial p_n}, \quad (1.26)$$

$$\dot{p}_n = -\frac{\partial \mathcal{H}}{\partial q_n}, \quad (1.27)$$

$$-\frac{\partial \mathcal{L}}{\partial t} = \frac{\partial \mathcal{H}}{\partial t}. \quad (1.28)$$

Corollary 1.3.1. *The following holds*

$$\frac{d\mathcal{H}}{dt} = \frac{\partial \mathcal{H}}{\partial t}. \quad (1.29)$$

Proof. Using Eqs. (1.23) and (1.24) one finds that

$$\frac{d\mathcal{H}}{dt} = \sum_{n=1}^N \underbrace{\left(\frac{\partial \mathcal{H}}{\partial q_n} \dot{q}_n + \frac{\partial \mathcal{H}}{\partial p_n} \dot{p}_n \right)}_{=0} + \frac{\partial \mathcal{H}}{\partial t} = \frac{\partial \mathcal{H}}{\partial t}. \quad (1.30)$$

The last corollary implies that \mathcal{H} is time independent provided that \mathcal{H} does not depend on time explicitly, namely, provided that $\partial \mathcal{H} / \partial t = 0$. This property is referred to as the law of energy conservation. The theorem below further emphasizes the relation between the Hamiltonian and the total energy of the system.

Theorem 1.3.2. *Assume that the kinetic energy of a conservative system is given by*

$$T = \sum_{n,m} \alpha_{nm} \dot{q}_n \dot{q}_m, \quad (1.31)$$

where α_{nm} are constants. Then, the Hamiltonian of the system is given by

$$\mathcal{H} = T + U, \quad (1.32)$$

where T is the kinetic energy of the system and where U is the potential energy.

Proof. For a conservative system the potential energy is independent on velocities, thus

$$p_l = \frac{\partial \mathcal{L}}{\partial \dot{q}_l} = \frac{\partial T}{\partial \dot{q}_l}, \quad (1.33)$$

where $\mathcal{L} = T - U$ is the Lagrangian. The Hamiltonian is thus given by

$$\begin{aligned}
\mathcal{H} &= \sum_{l=1}^N p_l \dot{q}_l - \mathcal{L} \\
&= \sum_l \frac{\partial T}{\partial \dot{q}_l} \dot{q}_l - (T - U) \\
&= \sum_{l,n,m} \alpha_{nm} \left(\underbrace{\dot{q}_m \frac{\partial \dot{q}_n}{\partial \dot{q}_l}}_{\delta_{nl}} + \underbrace{\dot{q}_n \frac{\partial \dot{q}_m}{\partial \dot{q}_l}}_{\delta_{ml}} \right) \dot{q}_l - T + U \\
&= 2 \underbrace{\sum_{n,m} \alpha_{nm} \dot{q}_n \dot{q}_m}_T - T + U \\
&= T + U .
\end{aligned} \tag{1.34}$$

1.4 Poisson's Brackets

Consider two physical quantities F and G that can be expressed as a function of the vector of coordinates Q , the vector of canonical conjugate variables P and time t , namely

$$F = F(Q, P; t) , \tag{1.35}$$

$$G = G(Q, P; t) , \tag{1.36}$$

The Poisson's brackets are defined by

$$\{F, G\} = \sum_{n=1}^N \left(\frac{\partial F}{\partial q_n} \frac{\partial G}{\partial p_n} - \frac{\partial F}{\partial p_n} \frac{\partial G}{\partial q_n} \right) , \tag{1.37}$$

The Poisson's brackets are employed for writing an equation of motion for a general physical quantity of interest, as the following theorem shows.

Theorem 1.4.1. *Let F be a physical quantity that can be expressed as a function of the vector of coordinates Q , the vector of canonical conjugate variables P and time t , and let \mathcal{H} be the Hamiltonian. Then, the following holds*

$$\frac{dF}{dt} = \{F, \mathcal{H}\} + \frac{\partial F}{\partial t} . \tag{1.38}$$

Proof. Using Eqs. (1.23) and (1.24) one finds that the time derivative of F is given by

$$\begin{aligned}
 \frac{dF}{dt} &= \sum_{n=1}^N \left(\frac{\partial F}{\partial q_n} \dot{q}_n + \frac{\partial F}{\partial p_n} \dot{p}_n \right) + \frac{\partial F}{\partial t} \\
 &= \sum_{n=1}^N \left(\frac{\partial F}{\partial q_n} \frac{\partial \mathcal{H}}{\partial p_n} - \frac{\partial F}{\partial p_n} \frac{\partial \mathcal{H}}{\partial q_n} \right) + \frac{\partial F}{\partial t} \\
 &= \{F, \mathcal{H}\} + \frac{\partial F}{\partial t}.
 \end{aligned}
 \tag{1.39}$$

Corollary 1.4.1. *If F does not explicitly depend on time, namely if $\partial F/\partial t = 0$, and if $\{F, \mathcal{H}\} = 0$, then F is a constant of the motion, namely*

$$\frac{dF}{dt} = 0.
 \tag{1.40}$$

1.5 Problems

1. Consider a particle having charge q and mass m in electromagnetic field characterized by the scalar potential φ and the vector potential \mathbf{A} . The electric field \mathbf{E} and the magnetic field \mathbf{B} are given by

$$\mathbf{E} = -\nabla\varphi - \frac{1}{c} \frac{\partial \mathbf{A}}{\partial t},
 \tag{1.41}$$

and

$$\mathbf{B} = \nabla \times \mathbf{A}.
 \tag{1.42}$$

Let $\mathbf{r} = (x, y, z)$ be the Cartesian coordinates of the particle.

- a) Verify that the Lagrangian of the system can be chosen to be given by

$$\mathcal{L} = \frac{1}{2} m \dot{\mathbf{r}}^2 - q\varphi + \frac{q}{c} \mathbf{A} \cdot \dot{\mathbf{r}},
 \tag{1.43}$$

by showing that the corresponding Euler-Lagrange equations are equivalent to Newton's 2nd law (i.e., $\mathbf{F} = m\ddot{\mathbf{r}}$).

- b) Show that the Hamilton-Jacobi equations are equivalent to Newton's 2nd law.
- c) **Gauge transformation** – The electromagnetic field is invariant under the gauge transformation of the scalar and vector potentials

$$\mathbf{A} \rightarrow \mathbf{A} + \nabla\chi,
 \tag{1.44}$$

$$\varphi \rightarrow \varphi - \frac{1}{c} \frac{\partial \chi}{\partial t}
 \tag{1.45}$$

where $\chi = \chi(\mathbf{r}, t)$ is an arbitrary smooth and continuous function of \mathbf{r} and t . What effect does this gauge transformation have on the Lagrangian and Hamiltonian? Is the motion affected?

Fig. 1.3. LC resonator.

2. Consider an LC resonator made of a capacitor having capacitance C in parallel with an inductor having inductance L (see Fig. 1.3). The state of the system is characterized by the coordinate q , which is the charge stored by the capacitor.

- a) Find the Euler-Lagrange equation of the system.
- b) Find the Hamilton-Jacobi equations of the system.
- c) Show that $\{q, p\} = 1$.

3. Show that Poisson brackets satisfy the following relations

$$\{q_j, q_k\} = 0, \quad (1.46)$$

$$\{p_j, p_k\} = 0, \quad (1.47)$$

$$\{q_j, p_k\} = \delta_{jk}, \quad (1.48)$$

$$\{F, G\} = -\{G, F\}, \quad (1.49)$$

$$\{F, F\} = 0, \quad (1.50)$$

$$\{F, K\} = 0 \text{ if } K \text{ constant or } F \text{ depends only on } t, \quad (1.51)$$

$$\{E + F, G\} = \{E, G\} + \{F, G\}, \quad (1.52)$$

$$\{E, FG\} = \{E, F\}G + F\{E, G\}. \quad (1.53)$$

4. Show that the Lagrange equations are coordinate invariant.
5. Consider a point particle having mass m moving in a 3D central potential, namely a potential $V(r)$ that depends only on the distance $r = \sqrt{x^2 + y^2 + z^2}$ from the origin. Show that the angular momentum $\mathbf{L} = \mathbf{r} \times \mathbf{p}$ is a constant of the motion.

1.6 Solutions

1. The Lagrangian of the system (in Gaussian units) is taken to be given by

$$\mathcal{L} = \frac{1}{2}m\dot{\mathbf{r}}^2 - q\varphi + \frac{q}{c}\mathbf{A} \cdot \dot{\mathbf{r}}. \quad (1.54)$$

a) The Euler-Lagrange equation (1.8) for the coordinate x is given by

$$\frac{d}{dt} \frac{\partial \mathcal{L}}{\partial \dot{x}} = \frac{\partial \mathcal{L}}{\partial x}, \quad (1.55)$$

where

$$\frac{d}{dt} \frac{\partial \mathcal{L}}{\partial \dot{x}} = m\ddot{x} + \frac{q}{c} \left(\frac{\partial A_x}{\partial t} + \dot{x} \frac{\partial A_x}{\partial x} + \dot{y} \frac{\partial A_x}{\partial y} + \dot{z} \frac{\partial A_x}{\partial z} \right), \quad (1.56)$$

and

$$\frac{\partial \mathcal{L}}{\partial x} = -q \frac{\partial \varphi}{\partial x} + \frac{q}{c} \left(\dot{x} \frac{\partial A_x}{\partial x} + \dot{y} \frac{\partial A_y}{\partial x} + \dot{z} \frac{\partial A_z}{\partial x} \right), \quad (1.57)$$

thus

$$m\ddot{x} = \underbrace{-q \frac{\partial \varphi}{\partial x} - \frac{q}{c} \frac{\partial A_x}{\partial t}}_{qE_x} + \frac{q}{c} \left[\underbrace{\dot{y} \left(\frac{\partial A_y}{\partial x} - \frac{\partial A_x}{\partial y} \right) - \dot{z} \left(\frac{\partial A_x}{\partial z} - \frac{\partial A_z}{\partial x} \right)}_{(\mathbf{r} \times (\nabla \times \mathbf{A}))_x} \right], \quad (1.58)$$

or

$$m\ddot{x} = qE_x + \frac{q}{c} (\mathbf{r} \times \mathbf{B})_x. \quad (1.59)$$

Similar equations are obtained for \dot{y} and \dot{z} in the same way. These 3 equations can be written in a vector form as

$$m\ddot{\mathbf{r}} = q \left(\mathbf{E} + \frac{1}{c} \dot{\mathbf{r}} \times \mathbf{B} \right). \quad (1.60)$$

b) The variable vector canonically conjugate to the coordinates vector \mathbf{r} is given by

$$\mathbf{p} = \frac{\partial \mathcal{L}}{\partial \dot{\mathbf{r}}} = m\dot{\mathbf{r}} + \frac{q}{c} \mathbf{A}. \quad (1.61)$$

The Hamiltonian is thus given by

$$\begin{aligned}
\mathcal{H} &= \mathbf{p} \cdot \dot{\mathbf{r}} - \mathcal{L} \\
&= \dot{\mathbf{r}} \cdot \left(\mathbf{p} - \frac{1}{2}m\dot{\mathbf{r}} - \frac{q}{c}\mathbf{A} \right) + q\varphi \\
&= \frac{1}{2}m\dot{\mathbf{r}}^2 + q\varphi \\
&= \frac{\left(\mathbf{p} - \frac{q}{c}\mathbf{A} \right)^2}{2m} + q\varphi .
\end{aligned} \tag{1.62}$$

The Hamilton-Jacobi equation for the coordinate x is given by

$$\dot{x} = \frac{\partial \mathcal{H}}{\partial p_x} , \tag{1.63}$$

thus

$$\dot{x} = \frac{p_x - \frac{q}{c}A_x}{m} , \tag{1.64}$$

or

$$p_x = m\dot{x} + \frac{q}{c}A_x . \tag{1.65}$$

The Hamilton-Jacobi equation for the canonically conjugate variable p_x is given by

$$\dot{p}_x = -\frac{\partial \mathcal{H}}{\partial x} , \tag{1.66}$$

where

$$\dot{p}_x = m\ddot{x} + \frac{q}{c} \left(\dot{x} \frac{\partial A_x}{\partial x} + \dot{y} \frac{\partial A_x}{\partial y} + \dot{z} \frac{\partial A_x}{\partial z} \right) + \frac{q}{c} \frac{\partial A_x}{\partial t} , \tag{1.67}$$

and

$$\begin{aligned}
-\frac{\partial \mathcal{H}}{\partial x} &= \frac{q}{c} \left(\frac{p_x - \frac{q}{c}A_x}{m} \frac{\partial A_x}{\partial x} + \frac{p_y - \frac{q}{c}A_y}{m} \frac{\partial A_y}{\partial x} + \frac{p_z - \frac{q}{c}A_z}{m} \frac{\partial A_z}{\partial x} \right) - q \frac{\partial \varphi}{\partial x} \\
&= \frac{q}{c} \left(\dot{x} \frac{\partial A_x}{\partial x} + \dot{y} \frac{\partial A_y}{\partial x} + \dot{z} \frac{\partial A_z}{\partial x} \right) - q \frac{\partial \varphi}{\partial x} ,
\end{aligned} \tag{1.68}$$

thus

$$m\ddot{x} = -q \frac{\partial \varphi}{\partial x} - \frac{q}{c} \frac{\partial A_x}{\partial t} + \frac{q}{c} \left[\dot{y} \left(\frac{\partial A_y}{\partial x} - \frac{\partial A_x}{\partial y} \right) - \dot{z} \left(\frac{\partial A_x}{\partial z} - \frac{\partial A_z}{\partial x} \right) \right] . \tag{1.69}$$

The last result is identical to Eq. (1.59).

- c) Clearly, the fields \mathbf{E} and \mathbf{B} , which are given by Eqs. (1.41) and (1.42) respectively, are unchanged since

$$\nabla \left(\frac{\partial \chi}{\partial t} \right) - \frac{\partial (\nabla \chi)}{\partial t} = 0, \quad (1.70)$$

and

$$\nabla \times (\nabla \chi) = 0. \quad (1.71)$$

Thus, even though both \mathcal{L} and \mathcal{H} are modified, the motion, which depends on \mathbf{E} and \mathbf{B} only, is unaffected. Note that the Lagrangian \mathcal{L} is transformed according to [see Eqs. (1.44), (1.45) and (1.54)]

$$\begin{aligned} \mathcal{L} &\rightarrow \mathcal{L} + \frac{q}{c} \left(\frac{\partial \chi}{\partial t} + \nabla \chi \cdot \dot{\mathbf{r}} \right) \\ &= \mathcal{L} + \frac{q}{c} \frac{d\chi}{dt}, \end{aligned} \quad (1.72)$$

and thus the action S is transformed according to [see Eq. (1.4)]

$$S \rightarrow S + \frac{q}{c} [\chi(\mathbf{r}(t_2)) - \chi(\mathbf{r}(t_1))]. \quad (1.73)$$

2. The kinetic energy in this case $T = L\dot{q}^2/2$ is the energy stored in the inductor, and the potential energy $U = q^2/2C$ is the energy stored in the capacitor.

- a) The Lagrangian is given by

$$\mathcal{L} = T - U = \frac{L\dot{q}^2}{2} - \frac{q^2}{2C}. \quad (1.74)$$

The Euler-Lagrange equation (1.8) for the coordinate q is given by

$$\frac{d}{dt} \frac{\partial \mathcal{L}}{\partial \dot{q}} = \frac{\partial \mathcal{L}}{\partial q}, \quad (1.75)$$

thus

$$L\ddot{q} + \frac{q}{C} = 0. \quad (1.76)$$

This equation expresses the requirement that the voltage across the capacitor is the same as the one across the inductor.

- b) The canonical conjugate momentum is given by

$$p = \frac{\partial \mathcal{L}}{\partial \dot{q}} = L\dot{q}, \quad (1.77)$$

and the Hamiltonian is given by

$$\mathcal{H} = p\dot{q} - \mathcal{L} = \frac{p^2}{2L} + \frac{q^2}{2C}. \quad (1.78)$$

Hamilton-Jacobi equations read

$$\dot{q} = \frac{p}{L} \quad (1.79)$$

$$\dot{p} = -\frac{q}{C}, \quad (1.80)$$

thus

$$L\ddot{q} + \frac{q}{C} = 0. \quad (1.81)$$

c) Using the definition (1.37) one has

$$\{q, p\} = \frac{\partial q}{\partial q} \frac{\partial p}{\partial p} - \frac{\partial q}{\partial p} \frac{\partial p}{\partial q} = 1. \quad (1.82)$$

3. All these relations are easily proven using the definition (1.37).
 4. Let $\mathcal{L} = \mathcal{L}(Q, \dot{Q}; t)$ be a Lagrangian of a system, where $Q = (q_1, q_2, \dots)$ is the vector of coordinates, $\dot{Q} = (\dot{q}_1, \dot{q}_2, \dots)$ is the vector of velocities, and where overdot denotes time derivative. Consider the coordinates transformation

$$x_a = x_a(q_1, q_2, \dots, t), \quad (1.83)$$

where $a = 1, 2, \dots$. The following holds

$$\dot{x}_a = \frac{\partial x_a}{\partial q_b} \dot{q}_b + \frac{\partial x_a}{\partial t}, \quad (1.84)$$

where the summation convention is being used, namely, repeated indices are summed over. Moreover

$$\frac{\partial \mathcal{L}}{\partial q_a} = \frac{\partial \mathcal{L}}{\partial x_b} \frac{\partial x_b}{\partial q_a} + \frac{\partial \mathcal{L}}{\partial \dot{x}_b} \frac{\partial \dot{x}_b}{\partial q_a}, \quad (1.85)$$

and

$$\frac{d}{dt} \left(\frac{\partial \mathcal{L}}{\partial \dot{q}_a} \right) = \frac{d}{dt} \left(\frac{\partial \mathcal{L}}{\partial \dot{x}_b} \frac{\partial \dot{x}_b}{\partial \dot{q}_a} \right). \quad (1.86)$$

As can be seen from Eq. (1.84), one has

$$\frac{\partial \dot{x}_b}{\partial \dot{q}_a} = \frac{\partial x_b}{\partial q_a}. \quad (1.87)$$

Thus, using Eqs. (1.85) and (1.86) one finds

$$\begin{aligned}
 \frac{d}{dt} \left(\frac{\partial \mathcal{L}}{\partial \dot{q}_a} \right) - \frac{\partial \mathcal{L}}{\partial q_a} &= \frac{d}{dt} \left(\frac{\partial \mathcal{L}}{\partial \dot{x}_b} \frac{\partial x_b}{\partial q_a} \right) \\
 &\quad - \frac{\partial \mathcal{L}}{\partial x_b} \frac{\partial x_b}{\partial q_a} - \frac{\partial \mathcal{L}}{\partial \dot{x}_b} \frac{\partial \dot{x}_b}{\partial q_a} \\
 &= \left[\frac{d}{dt} \left(\frac{\partial \mathcal{L}}{\partial \dot{x}_b} \right) - \frac{\partial \mathcal{L}}{\partial x_b} \right] \frac{\partial x_b}{\partial q_a} \\
 &\quad + \left[\frac{d}{dt} \left(\frac{\partial x_b}{\partial q_a} \right) - \frac{\partial \dot{x}_b}{\partial q_a} \right] \frac{\partial \mathcal{L}}{\partial \dot{x}_b} .
 \end{aligned} \tag{1.88}$$

As can be seen from Eq. (1.84), the second term vanishes since

$$\frac{\partial \dot{x}_b}{\partial q_a} = \frac{\partial^2 x_b}{\partial q_a \partial q_c} \dot{q}_c + \frac{\partial^2 x_b}{\partial t \partial q_a} = \frac{d}{dt} \left(\frac{\partial x_b}{\partial q_a} \right) ,$$

thus

$$\frac{d}{dt} \left(\frac{\partial \mathcal{L}}{\partial \dot{q}_a} \right) - \frac{\partial \mathcal{L}}{\partial q_a} = \left[\frac{d}{dt} \left(\frac{\partial \mathcal{L}}{\partial \dot{x}_b} \right) - \frac{\partial \mathcal{L}}{\partial x_b} \right] \frac{\partial x_b}{\partial q_a} . \tag{1.89}$$

The last result shows that if the coordinate transformation is reversible, namely if $\det(\partial x_b / \partial q_a) \neq 0$ then Lagrange equations are coordinate invariant.

5. The angular momentum \mathbf{L} is given by

$$\mathbf{L} = \mathbf{r} \times \mathbf{p} = \det \begin{pmatrix} \hat{\mathbf{x}} & \hat{\mathbf{y}} & \hat{\mathbf{z}} \\ x & y & z \\ p_x & p_y & p_z \end{pmatrix} , \tag{1.90}$$

where $\mathbf{r} = (x, y, z)$ is the position vector and where $\mathbf{p} = (p_x, p_y, p_z)$ is the momentum vector. The Hamiltonian is given by

$$\mathcal{H} = \frac{\mathbf{p}^2}{2m} + V(r) . \tag{1.91}$$

Using

$$\{x_i, p_j\} = \delta_{ij} , \tag{1.92}$$

$$L_z = xp_y - yp_x , \tag{1.93}$$

one finds that

$$\begin{aligned}
 \{\mathbf{p}^2, L_z\} &= \{p_x^2, L_z\} + \{p_y^2, L_z\} + \{p_z^2, L_z\} \\
 &= \{p_x^2, xp_y\} - \{p_y^2, yp_x\} \\
 &= -2p_x p_y + 2p_y p_x \\
 &= 0 ,
 \end{aligned} \tag{1.94}$$

and

$$\begin{aligned}\{\mathbf{r}^2, L_z\} &= \{x^2, L_z\} + \{y^2, L_z\} + \{z^2, L_z\} \\ &= -y\{x^2, p_x\} + \{y^2, p_y\}x \\ &= 0.\end{aligned}\tag{1.95}$$

Thus $\{f(\mathbf{r}^2), L_z\} = 0$ for arbitrary smooth function $f(\mathbf{r}^2)$, and consequently $\{\mathcal{H}, L_z\} = 0$. In a similar way one can show that $\{\mathcal{H}, L_x\} = \{\mathcal{H}, L_y\} = 0$, and therefore $\{\mathcal{H}, \mathbf{L}^2\} = 0$.

2. State Vectors and Operators

In quantum mechanics the state of a physical system is described by a state vector $|\alpha\rangle$, which is a vector in a vector space \mathcal{F} , namely

$$|\alpha\rangle \in \mathcal{F}. \quad (2.1)$$

Here, we have employed the Dirac's *ket-vector* notation $|\alpha\rangle$ for the state vector, which contains all information about the state of the physical system under study. The dimensionality of \mathcal{F} is finite in some specific cases (notably, spin systems), however, it can also be infinite in many other cases of interest. The basic mathematical theory dealing with vector spaces having infinite dimensionality was mainly developed by David Hilbert. Under some conditions, vector spaces having infinite dimensionality have properties similar to those of their finite dimensionality counterparts. A mathematically rigorous treatment of such vector spaces having infinite dimensionality, which are commonly called Hilbert spaces, can be found in textbooks that are devoted to this subject. In this chapter, however, we will only review the main properties that are useful for quantum mechanics. In some cases, when the generalization from the case of finite dimensionality to the case of arbitrary dimensionality is nontrivial, results will be presented without providing a rigorous proof and even without accurately specifying what are the validity conditions for these results.

2.1 Linear Vector Space

A linear vector space \mathcal{F} is a set $\{|\alpha\rangle\}$ of mathematical objects called vectors. The space is assumed to be closed under vector addition and scalar multiplication. Both, operations (i.e., vector addition and scalar multiplication) are commutative. That is:

1. $|\alpha\rangle + |\beta\rangle = |\beta\rangle + |\alpha\rangle \in \mathcal{F}$ for every $|\alpha\rangle \in \mathcal{F}$ and $|\beta\rangle \in \mathcal{F}$
2. $c|\alpha\rangle = |\alpha\rangle c \in \mathcal{F}$ for every $|\alpha\rangle \in \mathcal{F}$ and $c \in \mathcal{C}$ (where \mathcal{C} is the set of complex numbers)

A vector space with an inner product is called an inner product space. An inner product of the ordered pair $|\alpha\rangle, |\beta\rangle \in \mathcal{F}$ is denoted as $\langle\beta|\alpha\rangle$. The inner product is a function $\mathcal{F}^2 \rightarrow \mathcal{C}$ that satisfies the following properties:

$$\langle \beta | \alpha \rangle \in \mathcal{C} , \quad (2.2)$$

$$\langle \beta | \alpha \rangle = \langle \alpha | \beta \rangle^* , \quad (2.3)$$

$$\langle \alpha | (c_1 |\beta_1\rangle + c_2 |\beta_2\rangle) = c_1 \langle \alpha | \beta_1 \rangle + c_2 \langle \alpha | \beta_2 \rangle , \text{ where } c_1, c_2 \in \mathcal{C} , \quad (2.4)$$

$$\langle \alpha | \alpha \rangle \in \mathcal{R} \text{ and } \langle \alpha | \alpha \rangle \geq 0. \text{ Equality holds iff } |\alpha\rangle = 0 . \quad (2.5)$$

Note that the asterisk in Eq. (2.3) denotes complex conjugate. Below we list some important definitions and comments regarding inner product:

- The real number $\sqrt{\langle \alpha | \alpha \rangle}$ is called the *norm* of the vector $|\alpha\rangle \in \mathcal{F}$.
- A *normalized* vector has a unity norm, namely $\langle \alpha | \alpha \rangle = 1$.
- Every nonzero vector $0 \neq |\alpha\rangle \in \mathcal{F}$ can be normalized using the transformation

$$|\alpha\rangle \rightarrow \frac{|\alpha\rangle}{\sqrt{\langle \alpha | \alpha \rangle}} . \quad (2.6)$$

- The vectors $|\alpha\rangle \in \mathcal{F}$ and $|\beta\rangle \in \mathcal{F}$ are said to be orthogonal if $\langle \beta | \alpha \rangle = 0$.
- A set of vectors $\{|\phi_n\rangle\}_n$, where $|\phi_n\rangle \in \mathcal{F}$ is called a *complete orthonormal basis* if
 - The vectors are all normalized and orthogonal to each other, namely

$$\langle \phi_m | \phi_n \rangle = \delta_{nm} . \quad (2.7)$$

- Every $|\alpha\rangle \in \mathcal{F}$ can be written as a superposition of the basis vectors, namely

$$|\alpha\rangle = \sum_n c_n |\phi_n\rangle , \quad (2.8)$$

where $c_n \in \mathcal{C}$.

- By evaluating the inner product $\langle \phi_m | \alpha \rangle$, where $|\alpha\rangle$ is given by Eq. (2.8) one finds with the help of Eq. (2.7) and property (2.4) of inner products that

$$\langle \phi_m | \alpha \rangle = \langle \phi_m | \left(\sum_n c_n |\phi_n\rangle \right) = \sum_n c_n \underbrace{\langle \phi_m | \phi_n \rangle}_{=\delta_{nm}} = c_m . \quad (2.9)$$

- The last result allows rewriting Eq. (2.8) as

$$|\alpha\rangle = \sum_n c_n |\phi_n\rangle = \sum_n |\phi_n\rangle c_n = \sum_n |\phi_n\rangle \langle \phi_n | \alpha \rangle . \quad (2.10)$$

2.2 Operators

Operators, as the definition below states, are function from \mathcal{F} to \mathcal{F} :

Definition 2.2.1. An operator $A : \mathcal{F} \rightarrow \mathcal{F}$ on a vector space maps vectors onto vectors, namely $A|\alpha\rangle \in \mathcal{F}$ for every $|\alpha\rangle \in \mathcal{F}$.

Some important definitions and comments are listed below:

- The operators $X : \mathcal{F} \rightarrow \mathcal{F}$ and $Y : \mathcal{F} \rightarrow \mathcal{F}$ are said to be equal, namely $X = Y$, if for every $|\alpha\rangle \in \mathcal{F}$ the following holds

$$X|\alpha\rangle = Y|\alpha\rangle . \quad (2.11)$$

- Operators can be added, and the addition is both, commutative and associative, namely

$$X + Y = Y + X , \quad (2.12)$$

$$X + (Y + Z) = (X + Y) + Z . \quad (2.13)$$

- An operator $A : \mathcal{F} \rightarrow \mathcal{F}$ is said to be linear if

$$A(c_1|\gamma_1\rangle + c_2|\gamma_2\rangle) = c_1A|\gamma_1\rangle + c_2A|\gamma_2\rangle \quad (2.14)$$

for every $|\gamma_1\rangle, |\gamma_2\rangle \in \mathcal{F}$ and $c_1, c_2 \in \mathcal{C}$.

- The operators $X : \mathcal{F} \rightarrow \mathcal{F}$ and $Y : \mathcal{F} \rightarrow \mathcal{F}$ can be multiplied, where

$$XY|\alpha\rangle = X(Y|\alpha\rangle) \quad (2.15)$$

for any $|\alpha\rangle \in \mathcal{F}$.

- Operator multiplication is associative

$$X(YZ) = (XY)Z = XYZ . \quad (2.16)$$

- However, in general operator multiplication needs not be commutative

$$XY \neq YX . \quad (2.17)$$

2.3 Dirac's notation

In Dirac's notation the inner product is considered as a multiplication of two mathematical objects called 'bra' and 'ket'

$$\langle\beta|\alpha\rangle = \underbrace{\langle\beta|}_{\text{bra}} \underbrace{|\alpha\rangle}_{\text{ket}} . \quad (2.18)$$

While the ket-vector $|\alpha\rangle$ is a vector in \mathcal{F} , the bra-vector $\langle\beta|$ represents a functional that maps any ket-vector $|\alpha\rangle \in \mathcal{F}$ to the complex number $\langle\beta|\alpha\rangle$.

While the multiplication of a bra-vector on the left and a ket-vector on the right represents inner product, the *outer product* is obtained by reversing the order

$$A_{\alpha\beta} = |\alpha\rangle \langle\beta| . \quad (2.19)$$

The outer product $A_{\alpha\beta}$ is clearly an operator since for any $|\gamma\rangle \in \mathcal{F}$ the object $A_{\alpha\beta} |\gamma\rangle$ is a ket-vector

$$A_{\alpha\beta} |\gamma\rangle = (|\beta\rangle \langle\alpha|) |\gamma\rangle = |\beta\rangle \underbrace{\langle\alpha|\gamma\rangle}_{\in \mathcal{C}} \in \mathcal{F} . \quad (2.20)$$

Moreover, according to property (2.4), $A_{\alpha\beta}$ is linear since for every $|\gamma_1\rangle, |\gamma_2\rangle \in \mathcal{F}$ and $c_1, c_2 \in \mathcal{C}$ the following holds

$$\begin{aligned} A_{\alpha\beta} (c_1 |\gamma_1\rangle + c_2 |\gamma_2\rangle) &= |\alpha\rangle \langle\beta| (c_1 |\gamma_1\rangle + c_2 |\gamma_2\rangle) \\ &= |\alpha\rangle (c_1 \langle\beta|\gamma_1\rangle + c_2 \langle\beta|\gamma_2\rangle) \\ &= c_1 A_{\alpha\beta} |\gamma_1\rangle + c_2 A_{\alpha\beta} |\gamma_2\rangle . \end{aligned} \quad (2.21)$$

With Dirac's notation Eq. (2.10) can be rewritten as

$$|\alpha\rangle = \left(\sum_n |\phi_n\rangle \langle\phi_n| \right) |\alpha\rangle . \quad (2.22)$$

Since the above identity holds for any $|\alpha\rangle \in \mathcal{F}$ one concludes that the quantity in brackets is the identity operator, which is denoted as 1, namely

$$1 = \sum_n |\phi_n\rangle \langle\phi_n| . \quad (2.23)$$

This result, which is called the *closure relation*, implies that any complete orthonormal basis can be used to express the identity operator.

2.4 Dual Correspondence

As we have mentioned above, the bra-vector $\langle\beta|$ represents a functional mapping any ket-vector $|\alpha\rangle \in \mathcal{F}$ to the complex number $\langle\beta|\alpha\rangle$. Moreover, since the inner product is linear [see property (2.4) above], such a mapping is linear, namely for every $|\gamma_1\rangle, |\gamma_2\rangle \in \mathcal{F}$ and $c_1, c_2 \in \mathcal{C}$ the following holds

$$\langle\beta| (c_1 |\gamma_1\rangle + c_2 |\gamma_2\rangle) = c_1 \langle\beta|\gamma_1\rangle + c_2 \langle\beta|\gamma_2\rangle . \quad (2.24)$$

The set of linear functionals from \mathcal{F} to \mathcal{C} , namely, the set of functionals $F : \mathcal{F} \rightarrow \mathcal{C}$ that satisfy

$$F(c_1 |\gamma_1\rangle + c_2 |\gamma_2\rangle) = c_1 F(|\gamma_1\rangle) + c_2 F(|\gamma_2\rangle) \quad (2.25)$$

for every $|\gamma_1\rangle, |\gamma_2\rangle \in \mathcal{F}$ and $c_1, c_2 \in \mathcal{C}$, is called the dual space \mathcal{F}^* . As the name suggests, there is a dual correspondence (DC) between \mathcal{F} and \mathcal{F}^* , namely a one to one mapping between these two sets, which are both linear vector spaces. The duality relation is presented using the notation

$$\langle \alpha | \Leftrightarrow |\alpha\rangle, \quad (2.26)$$

where $|\alpha\rangle \in \mathcal{F}$ and $\langle \alpha | \in \mathcal{F}^*$. What is the dual of the ket-vector $|\gamma\rangle = c_1 |\gamma_1\rangle + c_2 |\gamma_2\rangle$, where $|\gamma_1\rangle, |\gamma_2\rangle \in \mathcal{F}$ and $c_1, c_2 \in \mathcal{C}$? To answer this question we employ the above mentioned general properties (2.3) and (2.4) of inner products and consider the quantity $\langle \gamma | \alpha \rangle$ for an arbitrary ket-vector $|\alpha\rangle \in \mathcal{F}$

$$\begin{aligned} \langle \gamma | \alpha \rangle &= \langle \alpha | \gamma \rangle^* \\ &= (c_1 \langle \alpha | \gamma_1 \rangle + c_2 \langle \alpha | \gamma_2 \rangle)^* \\ &= c_1^* \langle \gamma_1 | \alpha \rangle + c_2^* \langle \gamma_2 | \alpha \rangle \\ &= (c_1^* \langle \gamma_1 | + c_2^* \langle \gamma_2 |) |\alpha\rangle. \end{aligned} \quad (2.27)$$

From this result we conclude that the duality relation takes the form

$$c_1^* \langle \gamma_1 | + c_2^* \langle \gamma_2 | \Leftrightarrow c_1 |\gamma_1\rangle + c_2 |\gamma_2\rangle. \quad (2.28)$$

The last relation describes how to map any given ket-vector $|\beta\rangle \in \mathcal{F}$ to its dual $F = \langle \beta | : \mathcal{F} \rightarrow \mathcal{C}$, where $F \in \mathcal{F}^*$ is a linear functional that maps any ket-vector $|\alpha\rangle \in \mathcal{F}$ to the complex number $\langle \beta | \alpha \rangle$. What is the inverse mapping? The answer can take a relatively simple form provided that a complete orthonormal basis exists, and consequently the identity operator can be expressed as in Eq. (2.23). In that case the dual of a given linear functional $F : \mathcal{F} \rightarrow \mathcal{C}$ is the ket-vector $|F_D\rangle \in \mathcal{F}$, which is given by

$$|F_D\rangle = \sum_n (F(|\phi_n\rangle))^* |\phi_n\rangle. \quad (2.29)$$

The duality is demonstrated by proving the two claims below:

Claim. $|\beta_{\text{DD}}\rangle = |\beta\rangle$ for any $|\beta\rangle \in \mathcal{F}$, where $|\beta_{\text{DD}}\rangle$ is the dual of the dual of $|\beta\rangle$.

Proof. The dual of $|\beta\rangle$ is the bra-vector $\langle \beta |$, whereas the dual of $\langle \beta |$ is found using Eqs. (2.29) and (2.23), thus

$$\begin{aligned}
 |\beta_{\text{DD}}\rangle &= \sum_n \underbrace{\langle\beta|\phi_n\rangle^*}_{=\langle\phi_n|\beta\rangle} |\phi_n\rangle \\
 &= \sum_n |\phi_n\rangle \langle\phi_n|\beta\rangle \\
 &= \underbrace{\sum_n |\phi_n\rangle \langle\phi_n|}_{=1} |\beta\rangle \\
 &= |\beta\rangle .
 \end{aligned} \tag{2.30}$$

Claim. $F_{\text{DD}} = F$ for any $F \in \mathcal{F}^*$, where F_{DD} is the dual of the dual of F .

Proof. The dual $|F_{\text{D}}\rangle \in \mathcal{F}$ of the functional $F \in \mathcal{F}^*$ is given by Eq. (2.29). Thus with the help of the duality relation (2.28) one finds that dual $F_{\text{DD}} \in \mathcal{F}^*$ of $|F_{\text{D}}\rangle$ is given by

$$F_{\text{DD}} = \sum_n F(|\phi_n\rangle) \langle\phi_n| . \tag{2.31}$$

Consider an arbitrary ket-vector $|\alpha\rangle \in \mathcal{F}$ that is written as a superposition of the complete orthonormal basis vectors, namely

$$|\alpha\rangle = \sum_m c_m |\phi_m\rangle . \tag{2.32}$$

Using the above expression for F_{DD} and the linearity property one finds that

$$\begin{aligned}
 F_{\text{DD}} |\alpha\rangle &= \sum_{n,m} c_m F(|\phi_n\rangle) \underbrace{\langle\phi_n|\phi_m\rangle}_{\delta_{mn}} \\
 &= \sum_n c_n F(|\phi_n\rangle) \\
 &= F\left(\sum_n c_n |\phi_n\rangle\right) \\
 &= F(|\alpha\rangle) ,
 \end{aligned} \tag{2.33}$$

therefore, $F_{\text{DD}} = F$.

2.5 Matrix Representation

Given a complete orthonormal basis, ket-vectors, bra-vectors and linear operators can be represented using matrices. Such representations are easily obtained using the closure relation (2.23).

- The inner product between the bra-vector $\langle\beta|$ and the ket-vector $|\alpha\rangle$ can be written as

$$\begin{aligned}\langle\beta|\alpha\rangle &= \langle\beta|1|\alpha\rangle \\ &= \sum_n \langle\beta|\phi_n\rangle \langle\phi_n|\alpha\rangle \\ &= (\langle\beta|\phi_1\rangle \langle\beta|\phi_2\rangle \cdots) \begin{pmatrix} \langle\phi_1|\alpha\rangle \\ \langle\phi_2|\alpha\rangle \\ \vdots \end{pmatrix}.\end{aligned}\tag{2.34}$$

Thus, the inner product can be viewed as a product between the row vector

$$\langle\beta| \doteq (\langle\beta|\phi_1\rangle \langle\beta|\phi_2\rangle \cdots),\tag{2.35}$$

which is the matrix representation of the bra-vector $\langle\beta|$, and the column vector

$$|\alpha\rangle \doteq \begin{pmatrix} \langle\phi_1|\alpha\rangle \\ \langle\phi_2|\alpha\rangle \\ \vdots \end{pmatrix},\tag{2.36}$$

which is the matrix representation of the ket-vector $|\alpha\rangle$. Obviously, both representations are basis dependent.

- Multiplying the relation $|\gamma\rangle = X|\alpha\rangle$ from the left by the basis bra-vector $\langle\phi_m|$ and employing again the closure relation (2.23) yields

$$\langle\phi_m|\gamma\rangle = \langle\phi_m|X|\alpha\rangle = \langle\phi_m|X1|\alpha\rangle = \sum_n \langle\phi_m|X|\phi_n\rangle \langle\phi_n|\alpha\rangle,\tag{2.37}$$

or in matrix form

$$\begin{pmatrix} \langle\phi_1|\gamma\rangle \\ \langle\phi_2|\gamma\rangle \\ \vdots \end{pmatrix} = \begin{pmatrix} \langle\phi_1|X|\phi_1\rangle & \langle\phi_1|X|\phi_2\rangle & \cdots \\ \langle\phi_2|X|\phi_1\rangle & \langle\phi_2|X|\phi_2\rangle & \cdots \\ \vdots & \vdots & \ddots \end{pmatrix} \begin{pmatrix} \langle\phi_1|\alpha\rangle \\ \langle\phi_2|\alpha\rangle \\ \vdots \end{pmatrix}.\tag{2.38}$$

In view of this expression, the matrix representation of the linear operator X is given by

$$X \doteq \begin{pmatrix} \langle\phi_1|X|\phi_1\rangle & \langle\phi_1|X|\phi_2\rangle & \cdots \\ \langle\phi_2|X|\phi_1\rangle & \langle\phi_2|X|\phi_2\rangle & \cdots \\ \vdots & \vdots & \ddots \end{pmatrix}.\tag{2.39}$$

Alternatively, the last result can be written as

$$X_{nm} = \langle\phi_n|X|\phi_m\rangle,\tag{2.40}$$

where X_{nm} is the element in row n and column m of the matrix representation of the operator X .

- Such matrix representation of linear operators can be useful also for multiplying linear operators. The matrix elements of the product $Z = XY$ are given by

$$\langle \phi_m | Z | \phi_n \rangle = \langle \phi_m | XY | \phi_n \rangle = \langle \phi_m | X1Y | \phi_n \rangle = \sum_l \langle \phi_m | X | \phi_l \rangle \langle \phi_l | Y | \phi_n \rangle . \quad (2.41)$$

- Similarly, the matrix representation of the outer product $|\beta\rangle\langle\alpha|$ is given by

$$\begin{aligned} |\beta\rangle\langle\alpha| &\doteq \begin{pmatrix} \langle \phi_1 | \beta \rangle \\ \langle \phi_2 | \beta \rangle \\ \vdots \end{pmatrix} (\langle \alpha | \phi_1 \rangle \langle \alpha | \phi_2 \rangle \cdots) \\ &= \begin{pmatrix} \langle \phi_1 | \beta \rangle \langle \alpha | \phi_1 \rangle & \langle \phi_1 | \beta \rangle \langle \alpha | \phi_2 \rangle & \cdots \\ \langle \phi_2 | \beta \rangle \langle \alpha | \phi_1 \rangle & \langle \phi_2 | \beta \rangle \langle \alpha | \phi_2 \rangle & \cdots \\ \vdots & \vdots & \ddots \end{pmatrix} . \end{aligned} \quad (2.42)$$

2.6 Observables

Measurable physical variables are represented in quantum mechanics by Hermitian operators.

2.6.1 Hermitian Adjoint

Definition 2.6.1. *The Hermitian adjoint of an operator X is denoted as X^\dagger and is defined by the following duality relation*

$$\langle \alpha | X^\dagger \Leftrightarrow X | \alpha \rangle . \quad (2.43)$$

Namely, for any ket-vector $|\alpha\rangle \in \mathcal{F}$, the dual to the ket-vector $X|\alpha\rangle$ is the bra-vector $\langle \alpha | X^\dagger$.

Definition 2.6.2. *An operator is said to be Hermitian if $X = X^\dagger$.*

Below we prove some simple relations:

Claim. $\langle \beta | X | \alpha \rangle = \langle \alpha | X^\dagger | \beta \rangle^*$

Proof. Using the general property (2.3) of inner products one has

$$\langle \beta | X | \alpha \rangle = \langle \beta | (X | \alpha \rangle) = ((\langle \alpha | X^\dagger) | \beta \rangle)^* = \langle \alpha | X^\dagger | \beta \rangle^* . \quad (2.44)$$

Note that this result implies that if $X = X^\dagger$ then $\langle \beta | X | \alpha \rangle = \langle \alpha | X | \beta \rangle^*$.

Claim. $(X^\dagger)^\dagger = X$

Proof. For any $|\alpha\rangle, |\beta\rangle \in \mathcal{F}$ the following holds

$$\langle\beta|X|\alpha\rangle = (\langle\beta|X|\alpha\rangle^*)^* = \langle\alpha|X^\dagger|\beta\rangle^* = \langle\beta|(X^\dagger)^\dagger|\alpha\rangle, \quad (2.45)$$

thus $(X^\dagger)^\dagger = X$.

Claim. $(XY)^\dagger = Y^\dagger X^\dagger$

Proof. Applying XY on an arbitrary ket-vector $|\alpha\rangle \in \mathcal{F}$ and employing the duality correspondence yield

$$XY|\alpha\rangle = X(Y|\alpha\rangle) \Leftrightarrow (\langle\alpha|Y^\dagger)X^\dagger = \langle\alpha|Y^\dagger X^\dagger, \quad (2.46)$$

thus

$$(XY)^\dagger = Y^\dagger X^\dagger. \quad (2.47)$$

Claim. If $X = |\beta\rangle\langle\alpha|$ then $X^\dagger = |\alpha\rangle\langle\beta|$

Proof. By applying X on an arbitrary ket-vector $|\gamma\rangle \in \mathcal{F}$ and employing the duality correspondence one finds that

$$X|\gamma\rangle = (|\beta\rangle\langle\alpha|)|\gamma\rangle = |\beta\rangle(\langle\alpha|\gamma\rangle) \Leftrightarrow (\langle\alpha|\gamma\rangle)^*|\beta\rangle = \langle\gamma|\alpha\rangle|\beta\rangle = \langle\gamma|X^\dagger, \quad (2.48)$$

where $X^\dagger = |\alpha\rangle\langle\beta|$.

2.6.2 Eigenvalues and Eigenvectors

Each operator is characterized by its set of eigenvalues, which is defined below:

Definition 2.6.3. A number $a_n \in \mathcal{C}$ is said to be an eigenvalue of an operator $A : \mathcal{F} \rightarrow \mathcal{F}$ if for some nonzero ket-vector $|a_n\rangle \in \mathcal{F}$ the following holds

$$A|a_n\rangle = a_n|a_n\rangle. \quad (2.49)$$

The ket-vector $|a_n\rangle$ is then said to be an eigenvector of the operator A with an eigenvalue a_n .

The set of eigenvectors associated with a given eigenvalue of an operator A is called eigensubspace and is denoted as

$$\mathcal{F}_n = \{|a_n\rangle \in \mathcal{F} \text{ such that } A|a_n\rangle = a_n|a_n\rangle\}. \quad (2.50)$$

Clearly, \mathcal{F}_n is closed under vector addition and scalar multiplication, namely $c_1 |\gamma_1\rangle + c_2 |\gamma_2\rangle \in \mathcal{F}_n$ for every $|\gamma_1\rangle, |\gamma_2\rangle \in \mathcal{F}_n$ and for every $c_1, c_2 \in \mathcal{C}$. Thus, the set \mathcal{F}_n is a subspace of \mathcal{F} . The dimensionality of \mathcal{F}_n (i.e., the minimum number of vectors that are needed to span \mathcal{F}_n) is called the *level of degeneracy* g_n of the eigenvalue a_n , namely

$$g_n = \dim \mathcal{F}_n . \quad (2.51)$$

As the theorem below shows, the eigenvalues and eigenvectors of a Hermitian operator have some unique properties.

Theorem 2.6.1. *The eigenvalues of a Hermitian operator A are real. The eigenvectors of A corresponding to different eigenvalues are orthogonal.*

Proof. Let a_1 and a_2 be two eigenvalues of A with corresponding eigen vectors $|a_1\rangle$ and $|a_2\rangle$

$$A |a_1\rangle = a_1 |a_1\rangle , \quad (2.52)$$

$$A |a_2\rangle = a_2 |a_2\rangle . \quad (2.53)$$

Multiplying Eq. (2.52) from the left by the bra-vector $\langle a_2|$, and multiplying the dual of Eq. (2.53), which since $A = A^\dagger$ is given by

$$\langle a_2| A = a_2^* \langle a_2| , \quad (2.54)$$

from the right by the ket-vector $|a_1\rangle$ yield

$$\langle a_2| A |a_1\rangle = a_1 \langle a_2 |a_1\rangle , \quad (2.55)$$

$$\langle a_2| A |a_1\rangle = a_2^* \langle a_2 |a_1\rangle . \quad (2.56)$$

Thus, we have found that

$$(a_1 - a_2^*) \langle a_2 |a_1\rangle = 0 . \quad (2.57)$$

The first part of the theorem is proven by employing the last result (2.57) for the case where $|a_1\rangle = |a_2\rangle$. Since $|a_1\rangle$ is assumed to be a nonzero ket-vector one concludes that $a_1 = a_1^*$, namely a_1 is real. Since this is true for any eigenvalue of A , one can rewrite Eq. (2.57) as

$$(a_1 - a_2) \langle a_2 |a_1\rangle = 0 . \quad (2.58)$$

The second part of the theorem is proven by considering the case where $a_1 \neq a_2$, for which the above result (2.58) can hold only if $\langle a_2 |a_1\rangle = 0$. Namely eigenvectors corresponding to different eigenvalues are orthogonal.

Consider a Hermitian operator A having a set of eigenvalues $\{a_n\}_n$. Let g_n be the degree of degeneracy of eigenvalue a_n , namely g_n is the dimension of the corresponding eigensubspace, which is denoted by \mathcal{F}_n . For simplicity, assume that g_n is finite for every n . Let $\{|a_{n,1}\rangle, |a_{n,2}\rangle, \dots, |a_{n,g_n}\rangle\}$ be

an orthonormal basis of the eigensubspace \mathcal{F}_n , namely $\langle a_{n,i'} | a_{n,i} \rangle = \delta_{ii'}$. Constructing such an orthonormal basis for \mathcal{F}_n can be done by the so-called *Gram-Schmidt process*. Moreover, since eigenvectors of A corresponding to different eigenvalues are orthogonal, the following holds

$$\langle a_{n',i'} | a_{n,i} \rangle = \delta_{nn'} \delta_{ii'} , \quad (2.59)$$

In addition, all the ket-vectors $|a_{n,i}\rangle$ are eigenvectors of A

$$A |a_{n,i}\rangle = a_n |a_{n,i}\rangle . \quad (2.60)$$

Projectors. Projector operators are useful for expressing the properties of an observable.

Definition 2.6.4. *An Hermitian operator P is called a projector if*

$$P^2 = P . \quad (2.61)$$

Claim. The only possible eigenvalues of a projector are 0 and 1.

Proof. Assume that $|p\rangle$ is an eigenvector of P with an eigenvalue p , namely $P|p\rangle = p|p\rangle$. Applying the operator P on both sides and using the fact that $P^2 = P$ yield $P|p\rangle = p^2|p\rangle$, thus $p(1-p)|p\rangle = 0$, therefore since $|p\rangle$ is assumed to be nonzero, either $p = 0$ or $p = 1$.

A projector is said to project any given vector onto the eigensubspace corresponding to the eigenvalue $p = 1$.

Let $\{|a_{n,1}\rangle, |a_{n,2}\rangle, \dots, |a_{n,g_n}\rangle\}$ be an orthonormal basis of an eigensubspace \mathcal{F}_n corresponding to an eigenvalue of an observable A . Such an orthonormal basis can be used to construct a projection P_n onto \mathcal{F}_n , which is given by

$$P_n = \sum_{i=1}^{g_n} |a_{n,i}\rangle \langle a_{n,i}| . \quad (2.62)$$

Clearly, P_n is a projector since $P_n^\dagger = P_n$ and since

$$P_n^2 = \sum_{i,i'=1}^{g_n} |a_{n,i}\rangle \underbrace{\langle a_{n,i} | a_{n,i'} \rangle}_{\delta_{ii'}} \langle a_{n,i'}| = \sum_{i=1}^{g_n} |a_{n,i}\rangle \langle a_{n,i}| = P_n . \quad (2.63)$$

Moreover, it is easy to show using the orthonormality relation (2.59) that the following holds

$$P_n P_m = P_m P_n = P_n \delta_{nm} . \quad (2.64)$$

For linear vector spaces of finite dimensionality, it can be shown that the set $\{|a_{n,i}\rangle\}_{n,i}$ forms a complete orthonormal basis of eigenvectors of a given

Hermitian operator A . The generalization of this result for the case of arbitrary dimensionality is nontrivial, since generally such a set needs not be complete. On the other hand, it can be shown that if a given Hermitian operator A satisfies some conditions (e.g., A needs to be completely continuous) then completeness is guaranteed. For all Hermitian operators of interest for this course we will assume that all such conditions are satisfied. That is, for any such Hermitian operator A there exists a set of ket vectors $\{|a_{n,i}\rangle\}$, such that:

1. The set is orthonormal, namely

$$\langle a_{n',i'} | a_{n,i} \rangle = \delta_{nn'} \delta_{ii'} , \quad (2.65)$$

2. The ket-vectors $|a_{n,i}\rangle$ are eigenvectors, namely

$$A |a_{n,i}\rangle = a_n |a_{n,i}\rangle , \quad (2.66)$$

where $a_n \in \mathcal{R}$.

3. The set is complete, namely closure relation [see also Eq. (2.23)] is satisfied

$$1 = \sum_n \sum_{i=1}^{g_n} |a_{n,i}\rangle \langle a_{n,i}| = \sum_n P_n , \quad (2.67)$$

where

$$P_n = \sum_{i=1}^{g_n} |a_{n,i}\rangle \langle a_{n,i}| \quad (2.68)$$

is the projector onto eigen subspace \mathcal{F}_n with the corresponding eigenvalue a_n .

The closure relation (2.67) can be used to express the operator A in terms of the projectors P_n

$$A = A1 = \sum_n \sum_{i=1}^{g_n} A |a_{n,i}\rangle \langle a_{n,i}| = \sum_n a_n \sum_{i=1}^{g_n} |a_{n,i}\rangle \langle a_{n,i}| , \quad (2.69)$$

that is

$$A = \sum_n a_n P_n . \quad (2.70)$$

The last result is very useful when dealing with a function $f(A)$ of the operator A . The meaning of a function of an operator can be understood in terms of the Taylor expansion of the function

$$f(x) = \sum_m f_m x^m , \quad (2.71)$$

where

$$f_m = \frac{1}{m!} \frac{d^m f}{dx^m} . \quad (2.72)$$

With the help of Eqs. (2.64) and (2.70) one finds that

$$\begin{aligned} f(A) &= \sum_m f_m A^m \\ &= \sum_m f_m \left(\sum_n a_n P_n \right)^m \\ &= \sum_m f_m \sum_n a_n^m P_n \\ &= \sum_n \underbrace{\sum_m f_m a_n^m}_{f(a_n)} P_n , \end{aligned} \quad (2.73)$$

thus

$$f(A) = \sum_n f(a_n) P_n . \quad (2.74)$$

Exercise 2.6.1. Express the projector P_n in terms of the operator A and its set of eigenvalues.

Solution 2.6.1. We seek a function f such that $f(A) = P_n$. Multiplying from the right by a basis ket-vector $|a_{m,i}\rangle$ yields

$$f(A) |a_{m,i}\rangle = \delta_{mn} |a_{m,i}\rangle . \quad (2.75)$$

On the other hand

$$f(A) |a_{m,i}\rangle = f(a_m) |a_{m,i}\rangle . \quad (2.76)$$

Thus we seek a function that satisfy

$$f(a_m) = \delta_{mn} . \quad (2.77)$$

The polynomial function

$$f(a) = K \prod_{m \neq n} (a - a_m) , \quad (2.78)$$

where K is a constant, satisfies the requirement that $f(a_m) = 0$ for every $m \neq n$. The constant K is chosen such that $f(a_n) = 1$, that is

$$f(a) = \prod_{m \neq n} \frac{a - a_m}{a_n - a_m} , \quad (2.79)$$

Thus, the desired expression is given by

$$P_n = \prod_{m \neq n} \frac{A - a_m}{a_n - a_m}. \quad (2.80)$$

2.7 Quantum Measurement

Consider a measurement of a physical variable denoted as $A^{(c)}$ performed on a quantum system. The standard textbook description of such a process is described below. The physical variable $A^{(c)}$ is represented in quantum mechanics by an observable, namely by a Hermitian operator, which is denoted as A . The correspondence between the variable $A^{(c)}$ and the operator A will be discussed below in chapter 4. As we have seen above, it is possible to construct a complete orthonormal basis made of eigenvectors of the Hermitian operator A having the properties given by Eqs. (2.65), (2.66) and (2.67). In that basis, the vector state $|\alpha\rangle$ of the system can be expressed as

$$|\alpha\rangle = 1 |\alpha\rangle = \sum_n \sum_{i=1}^{g_n} \langle a_{n,i} | \alpha \rangle |a_{n,i}\rangle. \quad (2.81)$$

Even when the state vector $|\alpha\rangle$ is given, quantum mechanics does not generally provide a deterministic answer to the question: what will be the outcome of the measurement. Instead it predicts that:

1. The possible results of the measurement are the eigenvalues $\{a_n\}$ of the operator A .
2. The probability p_n to measure the eigenvalue a_n is given by

$$p_n = \langle \alpha | P_n | \alpha \rangle = \sum_{i=1}^{g_n} |\langle a_{n,i} | \alpha \rangle|^2. \quad (2.82)$$

Note that the state vector $|\alpha\rangle$ is assumed to be normalized.

3. After a measurement of A with an outcome a_n the state vector *collapses* onto the corresponding eigensubspace and becomes

$$|\alpha\rangle \rightarrow \frac{P_n |\alpha\rangle}{\sqrt{\langle \alpha | P_n | \alpha \rangle}}. \quad (2.83)$$

It is easy to show that the probability to measure something is unity provided that $|\alpha\rangle$ is normalized:

$$\sum_n p_n = \sum_n \langle \alpha | P_n | \alpha \rangle = \langle \alpha | \left(\sum_n P_n \right) | \alpha \rangle = 1. \quad (2.84)$$

We also note that a direct consequence of the collapse postulate is that two subsequent measurements of the same observable performed one immediately after the other will yield the same result. It is also important to note that the above 'standard textbook description' of the measurement process is highly controversial, especially, the collapse postulate. However, a thorough discussion of this issue is beyond the scope of this course.

Quantum mechanics cannot generally predict the outcome of a specific measurement of an observable A , however it can predict the average, namely the *expectation value*, which is denoted as $\langle A \rangle$. The expectation value is easily calculated with the help of Eq. (2.70)

$$\langle A \rangle = \sum_n a_n p_n = \sum_n a_n \langle \alpha | P_n | \alpha \rangle = \langle \alpha | A | \alpha \rangle . \quad (2.85)$$

2.8 Example - Spin 1/2

Spin is an internal degree of freedom of elementary particles. Electrons, for example, have spin 1/2. This means, as we will see in chapter 6, that the state of a spin 1/2 can be described by a state vector $|\alpha\rangle$ in a vector space of dimensionality 2. In other words, spin 1/2 is said to be a two-level system. The spin was first discovered in 1921 by Stern and Gerlach in an experiment in which the magnetic moment of neutral silver atoms was measured. Silver atoms have 47 electrons, 46 out of which fill closed shells. It can be shown that only the electron in the outer shell contributes to the total magnetic moment of the atom. The force \mathbf{F} acting on a magnetic moment $\boldsymbol{\mu}$ moving in a magnetic field \mathbf{B} is given by $\mathbf{F} = \nabla (\boldsymbol{\mu} \cdot \mathbf{B})$. Thus by applying a nonuniform magnetic field \mathbf{B} and by monitoring the atoms' trajectories one can measure the magnetic moment.

It is important to keep in mind that generally in addition to the spin contribution to the magnetic moment of an electron, also the orbital motion of the electron can contribute. For both cases, the magnetic moment is related to angular momentum by the gyromagnetic ratio. However this ratio takes different values for these two cases. The orbital gyromagnetic ratio can be evaluated by considering a simple example of an electron of charge e moving in a circular orbit of radius r with velocity v . The magnetic moment is given by

$$\mu_{\text{orbital}} = \frac{AI}{c} , \quad (2.86)$$

where $A = \pi r^2$ is the area enclosed by the circular orbit and $I = ev / (2\pi r)$ is the electrical current carried by the electron, thus

$$\mu_{\text{orbital}} = \frac{erv}{2c} . \quad (2.87)$$

This result can be also written as

$$\mu_{\text{orbital}} = \frac{\mu_{\text{B}}}{\hbar} L, \quad (2.88)$$

where $L = m_e v r$ is the orbital angular momentum, and where

$$\mu_{\text{B}} = \frac{e\hbar}{2m_e c} \quad (2.89)$$

is the Bohr's magneton constant. The proportionality factor μ_{B}/\hbar is the orbital gyromagnetic ratio. In vector form and for a more general case of orbital motion (not necessarily circular) the orbital gyromagnetic relation is given by

$$\boldsymbol{\mu}_{\text{orbital}} = \frac{\mu_{\text{B}}}{\hbar} \mathbf{L}. \quad (2.90)$$

On the other hand, as was first shown by Dirac, the gyromagnetic ratio for the case of spin angular momentum takes twice this value

$$\boldsymbol{\mu}_{\text{spin}} = \frac{2\mu_{\text{B}}}{\hbar} \mathbf{S}. \quad (2.91)$$

Note that we follow here the convention of using the letter \mathbf{L} for orbital angular momentum and the letter \mathbf{S} for spin angular momentum.

The Stern-Gerlach apparatus allows measuring any component of the magnetic moment vector. Alternatively, in view of relation (2.91), it can be said that any component of the spin angular momentum \mathbf{S} can be measured. The experiment shows that the only two possible results of such a measurement are $+\hbar/2$ and $-\hbar/2$. As we have seen above, one can construct a complete orthonormal basis to the vector space made of eigenvectors of any given observable. Choosing the observable $S_z = \mathbf{S} \cdot \hat{\mathbf{z}}$ for this purpose we construct a basis made of two vectors $\{|+; \hat{\mathbf{z}}\rangle, |-; \hat{\mathbf{z}}\rangle\}$. Both vectors are eigenvectors of S_z

$$S_z |+; \hat{\mathbf{z}}\rangle = \frac{\hbar}{2} |+; \hat{\mathbf{z}}\rangle, \quad (2.92)$$

$$S_z |-; \hat{\mathbf{z}}\rangle = -\frac{\hbar}{2} |-; \hat{\mathbf{z}}\rangle. \quad (2.93)$$

In what follow we will use the more compact notation

$$|+\rangle = |+; \hat{\mathbf{z}}\rangle, \quad (2.94)$$

$$|-\rangle = |-; \hat{\mathbf{z}}\rangle. \quad (2.95)$$

The orthonormality property implied that

$$\langle + | + \rangle = \langle - | - \rangle = 1, \quad (2.96)$$

$$\langle - | + \rangle = 0. \quad (2.97)$$

The closure relation in the present case is expressed as

$$|+\rangle \langle +| + |-\rangle \langle -| = 1 . \quad (2.98)$$

In this basis any ket-vector $|\alpha\rangle$ can be written as

$$|\alpha\rangle = |+\rangle \langle +|\alpha\rangle + |-\rangle \langle -|\alpha\rangle . \quad (2.99)$$

The closure relation (2.98) and Eqs. (2.92) and (2.93) yield

$$S_z = \frac{\hbar}{2} (|+\rangle \langle +| - |-\rangle \langle -|) \quad (2.100)$$

It is useful to define also the operators S_+ and S_-

$$S_+ = \hbar |+\rangle \langle -| , \quad (2.101)$$

$$S_- = \hbar |-\rangle \langle +| . \quad (2.102)$$

In chapter 6 we will see that the x and y components of \mathbf{S} are given by

$$S_x = \frac{\hbar}{2} (|+\rangle \langle -| + |-\rangle \langle +|) , \quad (2.103)$$

$$S_y = \frac{\hbar}{2} (-i |+\rangle \langle -| + i |-\rangle \langle +|) . \quad (2.104)$$

All these ket-vectors and operators have matrix representation, which for the basis $\{|+; \hat{\mathbf{z}}\rangle, |-; \hat{\mathbf{z}}\rangle\}$ is given by

$$|+\rangle \doteq \begin{pmatrix} 1 \\ 0 \end{pmatrix} , \quad (2.105)$$

$$|-\rangle \doteq \begin{pmatrix} 0 \\ 1 \end{pmatrix} , \quad (2.106)$$

$$S_x \doteq \frac{\hbar}{2} \begin{pmatrix} 0 & 1 \\ 1 & 0 \end{pmatrix} , \quad (2.107)$$

$$S_y \doteq \frac{\hbar}{2} \begin{pmatrix} 0 & -i \\ i & 0 \end{pmatrix} , \quad (2.108)$$

$$S_z \doteq \frac{\hbar}{2} \begin{pmatrix} 1 & 0 \\ 0 & -1 \end{pmatrix} , \quad (2.109)$$

$$S_+ \doteq \hbar \begin{pmatrix} 0 & 1 \\ 0 & 0 \end{pmatrix} , \quad (2.110)$$

$$S_- \doteq \hbar \begin{pmatrix} 0 & 0 \\ 1 & 0 \end{pmatrix} . \quad (2.111)$$

Exercise 2.8.1. Given that the state vector of a spin 1/2 is $|+; \hat{\mathbf{z}}\rangle$ calculate (a) the expectation values $\langle S_x \rangle$ and $\langle S_z \rangle$ (b) the probability to obtain a value of $+\hbar/2$ in a measurement of S_x .

Solution 2.8.1. (a) Using the matrix representation one has

$$\langle S_x \rangle = \langle + | S_x | + \rangle = \frac{\hbar}{2} (1 \ 0) \begin{pmatrix} 0 & 1 \\ 1 & 0 \end{pmatrix} \begin{pmatrix} 1 \\ 0 \end{pmatrix} = 0, \quad (2.112)$$

$$\langle S_z \rangle = \langle + | S_z | + \rangle = \frac{\hbar}{2} (1 \ 0) \begin{pmatrix} 1 & 0 \\ 0 & -1 \end{pmatrix} \begin{pmatrix} 1 \\ 0 \end{pmatrix} = \frac{\hbar}{2}. \quad (2.113)$$

(b) First, the eigenvectors of the operator S_x are found by solving the equation $S_x |\alpha\rangle = \lambda |\alpha\rangle$, which is done by diagonalization of the matrix representation of S_x . The relation $S_x |\alpha\rangle = \lambda |\alpha\rangle$ for the two eigenvectors is written in a matrix form as

$$\frac{\hbar}{2} \begin{pmatrix} 0 & 1 \\ 1 & 0 \end{pmatrix} \begin{pmatrix} \frac{1}{\sqrt{2}} \\ \frac{1}{\sqrt{2}} \end{pmatrix} = \frac{\hbar}{2} \begin{pmatrix} \frac{1}{\sqrt{2}} \\ \frac{1}{\sqrt{2}} \end{pmatrix}, \quad (2.114)$$

$$\frac{\hbar}{2} \begin{pmatrix} 0 & 1 \\ 1 & 0 \end{pmatrix} \begin{pmatrix} \frac{1}{\sqrt{2}} \\ -\frac{1}{\sqrt{2}} \end{pmatrix} = -\frac{\hbar}{2} \begin{pmatrix} \frac{1}{\sqrt{2}} \\ -\frac{1}{\sqrt{2}} \end{pmatrix}. \quad (2.115)$$

That is, in ket notation

$$S_x |\pm; \hat{\mathbf{x}}\rangle = \pm \frac{\hbar}{2} |\pm; \hat{\mathbf{x}}\rangle, \quad (2.116)$$

where the eigenvectors of S_x are given by

$$|\pm; \hat{\mathbf{x}}\rangle = \frac{1}{\sqrt{2}} (|+\rangle \pm |-\rangle). \quad (2.117)$$

Using this result the probability p_+ is easily calculated

$$p_+ = |\langle + | +; \hat{\mathbf{x}} \rangle|^2 = \left| \langle + | \frac{1}{\sqrt{2}} (|+\rangle + |-\rangle) \right|^2 = \frac{1}{2}. \quad (2.118)$$

Alternatively, the probability p_+ can be calculated using Eq. (2.82)

$$p_+ = \langle \alpha | P_{+; \hat{\mathbf{x}}} | \alpha \rangle, \quad (2.119)$$

where the projection $P_{+; \hat{\mathbf{x}}}$ is evaluated with the help of Eq. (2.80)

$$P_{+; \hat{\mathbf{x}}} = \frac{S_x - (-\frac{\hbar}{2})}{\frac{\hbar}{2} - (-\frac{\hbar}{2})}, \quad (2.120)$$

thus [see Eq. (2.107)]

$$P_{+; \hat{\mathbf{x}}} \doteq \begin{pmatrix} \frac{1}{2} & \frac{1}{2} \\ \frac{1}{2} & \frac{1}{2} \end{pmatrix}, \quad (2.121)$$

and therefore

$$p_+ = (1 \ 0) \begin{pmatrix} \frac{1}{2} & \frac{1}{2} \\ \frac{1}{2} & \frac{1}{2} \end{pmatrix} \begin{pmatrix} 1 \\ 0 \end{pmatrix} = \frac{1}{2}. \quad (2.122)$$

2.9 Unitary Operators

Unitary operators are useful for transforming from one orthonormal basis to another.

Definition 2.9.1. An operator U is said to be unitary if $U^\dagger = U^{-1}$, namely if $UU^\dagger = U^\dagger U = 1$.

Consider two observables A and B , and two corresponding complete and orthonormal bases of eigenvectors

$$A|a_n\rangle = a_n|a_n\rangle, \langle a_m|a_n\rangle = \delta_{nm}, \sum_n |a_n\rangle\langle a_n| = 1, \quad (2.123)$$

$$B|b_n\rangle = b_n|b_n\rangle, \langle b_m|b_n\rangle = \delta_{nm}, \sum_n |b_n\rangle\langle b_n| = 1. \quad (2.124)$$

The operator U , which is given by

$$U = \sum_n |b_n\rangle\langle a_n|, \quad (2.125)$$

transforms each of the basis vector $|a_n\rangle$ to the corresponding basis vector $|b_n\rangle$

$$U|a_n\rangle = |b_n\rangle. \quad (2.126)$$

It is easy to show that the operator U is unitary

$$U^\dagger U = \sum_{n,m} |a_n\rangle\langle b_n| \underbrace{\langle b_m|b_n\rangle}_{\delta_{nm}} \langle a_m| = \sum_n |a_n\rangle\langle a_n| = 1. \quad (2.127)$$

The matrix elements of U in the basis $\{|a_n\rangle\}$ are given by

$$\langle a_n|U|a_m\rangle = \langle a_n|b_m\rangle, \quad (2.128)$$

and those of U^\dagger by

$$\langle a_n|U^\dagger|a_m\rangle = \langle b_n|a_m\rangle.$$

Consider a ket vector

$$|\alpha\rangle = \sum_n |a_n\rangle\langle a_n|\alpha\rangle, \quad (2.129)$$

which can be represented as a column vector in the basis $\{|a_n\rangle\}$. The n th element of such a column vector is $\langle a_n|\alpha\rangle$. The operator U can be employed for finding the corresponding column vector representation of the same ket-vector $|\alpha\rangle$ in the other basis $\{|b_n\rangle\}$

$$\langle b_n|\alpha\rangle = \sum_m \langle b_n|a_m\rangle\langle a_m|\alpha\rangle = \sum_m \langle a_n|U^\dagger|a_m\rangle\langle a_m|\alpha\rangle. \quad (2.130)$$

Similarly, Given an operator X the relation between the matrix elements $\langle a_n | X | a_m \rangle$ in the basis $\{|a_n\rangle\}$ to the matrix elements $\langle b_n | X | b_m \rangle$ in the basis $\{|b_n\rangle\}$ is given by

$$\begin{aligned} \langle b_n | X | b_m \rangle &= \sum_{k,l} \langle b_n | a_k \rangle \langle a_k | X | a_l \rangle \langle a_l | b_m \rangle \\ &= \sum_{k,l} \langle a_n | U^\dagger | a_k \rangle \langle a_k | X | a_l \rangle \langle a_l | U | a_m \rangle . \end{aligned} \tag{2.131}$$

2.10 Trace

Given an operator X and an orthonormal and complete basis $\{|a_n\rangle\}$, the trace of X is given by

$$\text{Tr}(X) = \sum_n \langle a_n | X | a_n \rangle . \tag{2.132}$$

It is easy to show that $\text{Tr}(X)$ is independent on basis, as is shown below:

$$\begin{aligned} \text{Tr}(X) &= \sum_n \langle a_n | X | a_n \rangle \\ &= \sum_{n,k,l} \langle a_n | b_k \rangle \langle b_k | X | b_l \rangle \langle b_l | a_n \rangle \\ &= \sum_{n,k,l} \langle b_l | a_n \rangle \langle a_n | b_k \rangle \langle b_k | X | b_l \rangle \\ &= \sum_{k,l} \underbrace{\langle b_l | b_k \rangle}_{\delta_{kl}} \langle b_k | X | b_l \rangle \\ &= \sum_k \langle b_k | X | b_k \rangle . \end{aligned} \tag{2.133}$$

Claim. The following holds

$$\text{Tr}(XY) = \text{Tr}(YX) . \tag{2.134}$$

Proof. With the help of the closure relation (2.23) one finds that

$$\begin{aligned}
 \text{Tr}(XY) &= \sum_n \langle a_n | XY | a_n \rangle \\
 &= \sum_{n,m} \langle a_n | X | a_m \rangle \langle a_m | Y | a_n \rangle \\
 &= \sum_{n,m} \langle a_m | Y | a_n \rangle \langle a_n | X | a_m \rangle \\
 &= \sum_m \langle a_m | YX | a_m \rangle \\
 &= \text{Tr}(YX) .
 \end{aligned} \tag{2.135}$$

2.11 Commutation Relation

The commutation relation of the operators A and B is defined as

$$[A, B] = AB - BA . \tag{2.136}$$

As an example, the components S_x , S_y and S_z of the spin angular momentum operator, satisfy the following commutation relations

$$[S_i, S_j] = i\hbar \varepsilon_{ijk} S_k , \tag{2.137}$$

where

$$\varepsilon_{ijk} = \begin{cases} 0 & i, j, k \text{ are not all different} \\ 1 & i, j, k \text{ is an even permutation of } x, y, z \\ -1 & i, j, k \text{ is an odd permutation of } x, y, z \end{cases} \tag{2.138}$$

is the Levi-Civita symbol. Equation (2.137) employs the Einstein's convention, according to which if an index symbol appears twice in an expression, it is to be summed over all its allowed values. Namely, the repeated index k should be summed over the values x , y and z :

$$\varepsilon_{ijk} S_k = \varepsilon_{ijx} S_x + \varepsilon_{ijy} S_y + \varepsilon_{ijz} S_z . \tag{2.139}$$

Moreover, the following relations hold

$$S_x^2 = S_y^2 = S_z^2 = \frac{1}{4} \hbar^2 , \tag{2.140}$$

$$\mathbf{S}^2 = S_x^2 + S_y^2 + S_z^2 = \frac{3}{4} \hbar^2 . \tag{2.141}$$

The relations below, which are easy to prove using the above definition, are very useful for evaluating commutation relations

$$[F, G] = -[G, F] , \tag{2.142}$$

$$[F, F] = 0 , \tag{2.143}$$

$$[E + F, G] = [E, G] + [F, G] , \tag{2.144}$$

$$[E, FG] = [E, F]G + F[E, G] . \tag{2.145}$$

2.12 Simultaneous Diagonalization of Commuting Operators

Consider an observable A having a set of eigenvalues $\{a_n\}$. Let g_n be the degree of degeneracy of eigenvalue a_n , namely g_n is the dimension of the corresponding eigensubspace, which is denoted by \mathcal{F}_n . Thus the following holds

$$A |a_{n,i}\rangle = a_n |a_{n,i}\rangle , \quad (2.146)$$

where $i = 1, 2, \dots, g_n$, and

$$\langle a_{n',i'} | a_{n,i}\rangle = \delta_{nn'} \delta_{ii'} . \quad (2.147)$$

The set of vectors $\{|a_{n,1}\rangle, |a_{n,2}\rangle, \dots, |a_{n,g_n}\rangle\}$ forms an orthonormal basis for the eigensubspace \mathcal{F}_n . The closure relation can be written as

$$1 = \sum_n \sum_{i=1}^{g_n} |a_{n,i}\rangle \langle a_{n,i}| = \sum_n P_n , \quad (2.148)$$

where

$$P_n = \sum_{i=1}^{g_n} |a_{n,i}\rangle \langle a_{n,i}| . \quad (2.149)$$

Now consider another observable B , which is assumed to commute with A , namely $[A, B] = 0$.

Claim. The operator B has a block diagonal matrix in the basis $\{|a_{n,i}\rangle\}$, namely $\langle a_{m,j} | B |a_{n,i}\rangle = 0$ for $n \neq m$.

Proof. Multiplying Eq. (2.146) from the left by $\langle a_{m,j} | B$ yields

$$\langle a_{m,j} | BA |a_{n,i}\rangle = a_n \langle a_{m,j} | B |a_{n,i}\rangle . \quad (2.150)$$

On the other hand, since $[A, B] = 0$ one has

$$\langle a_{m,j} | BA |a_{n,i}\rangle = \langle a_{m,j} | AB |a_{n,i}\rangle = a_m \langle a_{m,j} | B |a_{n,i}\rangle , \quad (2.151)$$

thus

$$(a_n - a_m) \langle a_{m,j} | B |a_{n,i}\rangle = 0 . \quad (2.152)$$

For a given n , the $g_n \times g_n$ matrix $\langle a_{n,i'} | B |a_{n,i}\rangle$ is Hermitian, namely $\langle a_{n,i'} | B |a_{n,i}\rangle = \langle a_{n,i} | B |a_{n,i'}\rangle^*$. Thus, there exists a unitary transformation U_n , which maps \mathcal{F}_n onto \mathcal{F}_n , and which diagonalizes the block of B in the subspace \mathcal{F}_n . Since \mathcal{F}_n is an eigensubspace of A , the block matrix of A in the new basis remains diagonal (with the eigenvalue a_n). Thus, we conclude that a complete and orthonormal basis of common eigenvectors of both operators A and B exists. For such a basis, which is denoted as $\{|n, m\rangle\}$, the following holds

$$A |n, m\rangle = a_n |n, m\rangle , \quad (2.153)$$

$$B |n, m\rangle = b_m |n, m\rangle . \quad (2.154)$$

2.13 Uncertainty Principle

Consider a quantum system in a state $|n, m\rangle$, which is a common eigenvector of the commuting observables A and B . The outcome of a measurement of the observable A is expected to be a_n with unity probability, and similarly, the outcome of a measurement of the observable B is expected to be b_m with unity probability. In this case it is said that there is no uncertainty corresponding to both of these measurements.

Definition 2.13.1. *The variance in a measurement of a given observable A of a quantum system in a state $|\alpha\rangle$ is given by $\langle(\Delta A)^2\rangle$, where $\Delta A = A - \langle A\rangle$, namely*

$$\langle(\Delta A)^2\rangle = \langle A^2 - 2A\langle A\rangle + \langle A\rangle^2\rangle = \langle A^2\rangle - \langle A\rangle^2, \quad (2.155)$$

where

$$\langle A\rangle = \langle\alpha|A|\alpha\rangle, \quad (2.156)$$

$$\langle A^2\rangle = \langle\alpha|A^2|\alpha\rangle. \quad (2.157)$$

Example 2.13.1. Consider a spin 1/2 system in a state $|\alpha\rangle = |+\hat{z}\rangle$. Using Eqs. (2.100), (2.103) and (2.140) one finds that

$$\langle(\Delta S_z)^2\rangle = \langle S_z^2\rangle - \langle S_z\rangle^2 = 0, \quad (2.158)$$

$$\langle(\Delta S_x)^2\rangle = \langle S_x^2\rangle - \langle S_x\rangle^2 = \frac{1}{4}\hbar^2. \quad (2.159)$$

The last example raises the question: can one find a state $|\alpha\rangle$ for which the variance in the measurements of both S_z and S_x vanishes? According to the uncertainty principle the answer is no.

Theorem 2.13.1. *The uncertainty principle - Let A and B be two observables. For any ket-vector $|\alpha\rangle$ the following holds*

$$\langle(\Delta A)^2\rangle\langle(\Delta B)^2\rangle \geq \frac{1}{4}|\langle[A, B]\rangle|^2. \quad (2.160)$$

Proof. Applying the Schwartz inequality [see Eq. (2.172)], which is given by

$$\langle u|u\rangle\langle v|v\rangle \geq |\langle u|v\rangle|^2, \quad (2.161)$$

for the ket-vectors

$$|u\rangle = \Delta A|\alpha\rangle, \quad (2.162)$$

$$|v\rangle = \Delta B|\alpha\rangle, \quad (2.163)$$

and exploiting the fact that $(\Delta A)^\dagger = \Delta A$ and $(\Delta B)^\dagger = \Delta B$ yield

$$\langle (\Delta A)^2 \rangle \langle (\Delta B)^2 \rangle \geq |\langle \Delta A \Delta B \rangle|^2 . \quad (2.164)$$

The term $\Delta A \Delta B$ can be written as

$$\Delta A \Delta B = \frac{1}{2} [\Delta A, \Delta B] + \frac{1}{2} [\Delta A, \Delta B]_+ , \quad (2.165)$$

where

$$[\Delta A, \Delta B] = \Delta A \Delta B - \Delta B \Delta A , \quad (2.166)$$

$$[\Delta A, \Delta B]_+ = \Delta A \Delta B + \Delta B \Delta A . \quad (2.167)$$

While the term $[\Delta A, \Delta B]$ is anti-Hermitian, the term $[\Delta A, \Delta B]_+$ is Hermitian, namely

$$\begin{aligned} ([\Delta A, \Delta B])^\dagger &= (\Delta A \Delta B - \Delta B \Delta A)^\dagger = \Delta B \Delta A - \Delta A \Delta B = -[\Delta A, \Delta B] , \\ ([\Delta A, \Delta B]_+)^\dagger &= (\Delta A \Delta B + \Delta B \Delta A)^\dagger = \Delta B \Delta A + \Delta A \Delta B = [\Delta A, \Delta B]_+ . \end{aligned}$$

In general, the following holds

$$\langle \alpha | X | \alpha \rangle = \langle \alpha | X^\dagger | \alpha \rangle^* = \begin{cases} \langle \alpha | X | \alpha \rangle^* & \text{if } X \text{ is Hermitian} \\ -\langle \alpha | X | \alpha \rangle^* & \text{if } X \text{ is anti-Hermitian} \end{cases} , \quad (2.168)$$

thus

$$\langle \Delta A \Delta B \rangle = \frac{1}{2} \underbrace{\langle [\Delta A, \Delta B] \rangle}_{\in \mathcal{I}} + \frac{1}{2} \underbrace{\langle [\Delta A, \Delta B]_+ \rangle}_{\in \mathcal{R}} , \quad (2.169)$$

and consequently

$$|\langle \Delta A \Delta B \rangle|^2 = \frac{1}{4} |[\Delta A, \Delta B]|^2 + \frac{1}{4} |[\Delta A, \Delta B]_+|^2 . \quad (2.170)$$

Finally, with the help of the identity $[\Delta A, \Delta B] = [A, B]$ one finds that

$$\langle (\Delta A)^2 \rangle \langle (\Delta B)^2 \rangle \geq \frac{1}{4} |[A, B]|^2 . \quad (2.171)$$

2.14 Problems

1. Derive the Schwartz inequality

$$|\langle u | v \rangle| \leq \sqrt{\langle u | u \rangle} \sqrt{\langle v | v \rangle} , \quad (2.172)$$

where $|u\rangle$ and $|v\rangle$ are any two vectors of a vector space \mathcal{F} .

2. Derive the triangle inequality:

$$\sqrt{\langle (|u\rangle + |v\rangle) | (|u\rangle + |v\rangle) \rangle} \leq \sqrt{\langle u | u \rangle} + \sqrt{\langle v | v \rangle} . \quad (2.173)$$

3. Show that if a unitary operator U can be written in the form $U = 1 + i\epsilon F$, where ϵ is a real infinitesimally small number, then the operator F is Hermitian.
4. A Hermitian operator A is said to be positive-definite if, for any vector $|u\rangle$, $\langle u|A|u\rangle \geq 0$. Show that the operator $A = |a\rangle\langle a|$ is Hermitian and positive-definite.
5. Show that if A is a Hermitian positive-definite operator then the following hold

$$|\langle u|A|v\rangle| \leq \sqrt{\langle u|A|u\rangle}\sqrt{\langle v|A|v\rangle}. \quad (2.174)$$

6. Let A and B be Hermitian operators.
a) Show that

$$\text{Tr}(A^2B^2) \geq \text{Tr}((AB)^2), \quad (2.175)$$

- b) Show that

$$\text{Tr}(AB) \leq \frac{\text{Tr}(A^2) + \text{Tr}(B^2)}{2}. \quad (2.176)$$

- c) Show that

$$\text{Tr}(AB) \leq \sqrt{\text{Tr}(A^2)}\sqrt{\text{Tr}(B^2)}. \quad (2.177)$$

7. Find the expansion of the operator $(A - \lambda B)^{-1}$ in a power series in λ , assuming that the inverse A^{-1} of A exists.
8. The derivative of an operator $A(\lambda)$ which depends explicitly on a parameter λ is defined to be

$$\frac{dA(\lambda)}{d\lambda} = \lim_{\epsilon \rightarrow 0} \frac{A(\lambda + \epsilon) - A(\lambda)}{\epsilon}. \quad (2.178)$$

Show that

$$\frac{d}{d\lambda}(AB) = \frac{dA}{d\lambda}B + A\frac{dB}{d\lambda}. \quad (2.179)$$

9. Show that

$$\frac{d}{d\lambda}(A^{-1}) = -A^{-1}\frac{dA}{d\lambda}A^{-1}. \quad (2.180)$$

10. Let $|u\rangle$ and $|v\rangle$ be two vectors of finite norm. Show that

$$\text{Tr}(|u\rangle\langle v|) = \langle v|u\rangle. \quad (2.181)$$

11. If A is any linear operator, show that $A^\dagger A$ is a positive-definite Hermitian operator whose trace is equal to the sum of the square moduli of the matrix elements of A in any arbitrary representation. Deduce that $\text{Tr}(A^\dagger A) = 0$ is true if and only if $A = 0$.

12. Show that if A and B are two positive-definite observables, then $\text{Tr}(AB) \geq 0$.

13. Show that for any two operators A and L

$$e^L A e^{-L} = A + [L, A] + \frac{1}{2!} [L, [L, A]] + \frac{1}{3!} [L, [L, [L, A]]] + \dots \quad (2.182)$$

14. Show that if A and B are two operators satisfying the relation $[[A, B], A] = 0$, then the relation

$$[A^m, B] = mA^{m-1}[A, B] \quad (2.183)$$

holds for all positive integers m .

15. Show that

$$e^A e^B = e^{A+B} e^{(1/2)[A, B]}, \quad (2.184)$$

provided that $[[A, B], A] = 0$ and $[[A, B], B] = 0$.

16. For given two operators X and Y , show that

$$\text{Tr} \left(\frac{d \log(X + \epsilon Y)}{d\epsilon} X \right) = \text{Tr} Y. \quad (2.185)$$

17. Proof Kubo's identity

$$[A, e^{-\beta H}] = e^{-\beta H} \int_0^\beta e^{\lambda H} [H, A] e^{-\lambda H} d\lambda, \quad (2.186)$$

where A and H are any two operators and β is real.

18. Show that

$$[A_\rho, \log \rho] = [A, \rho], \quad (2.187)$$

where ρ is Hermitian, and where

$$A_\rho = \int_0^1 dq \rho^q A \rho^{1-q}. \quad (2.188)$$

19. Show that

$$\frac{d}{dt} e^{A(t)} = \int_0^1 d\eta e^{\eta A} \frac{dA}{dt} e^{(1-\eta)A}. \quad (2.189)$$

20. Show that $\text{Tr}(XY) = \text{Tr}(YX)$.

21. Consider the two normalized spin 1/2 states $|\alpha\rangle$ and $|\beta\rangle$. The operator A is defined as

$$A = |\alpha\rangle \langle \alpha| - |\beta\rangle \langle \beta|. \quad (2.190)$$

Find the eigenvalues of the operator A .

22. A one-dimensional equally-spaced array of N atoms is arranged along a circular ring. An electron occupies the ring. The state in which the electron is localized on the n 'th atom is denoted by $|\varphi_n\rangle$, where $n = 0, 1, 2, \dots, N-1$. The set of states $\{|\varphi_n\rangle\}_{n=0}^{N-1}$ forms a complete orthonormal basis. Each site interacts with its two nearest neighbors. The Hamiltonian of the system is given by

$$\mathcal{H} = E_0 \sum_{n=0}^{N-1} |\varphi_n\rangle \langle \varphi_n| - a \sum_{n=0}^{N-1} \left(|\varphi_n\rangle \langle \varphi_{(n+1)'}| + |\varphi_n\rangle \langle \varphi_{(n-1)'}| \right) . \quad (2.191)$$

where both E_0 and a are positive constants, and where prime denotes modulo N , i.e.

$$m' = \begin{cases} m & \text{if } 0 \leq m' \leq N-1 \\ 0 & \text{if } m' = N \\ N-1 & \text{if } m = -1 \end{cases} . \quad (2.192)$$

Find the eigenvalues and eigenvectors of \mathcal{H} .

23. A given Hermitian operator A has two distinct eigenvalues a_1 and a_2 .
- Express $f(A)$ in terms of A , $f(a_1)$ and $f(a_2)$, where f is a given smooth function.
 - Express the operator A^2 as $A^2 = q_0 + q_1 A$, where both numbers q_0 and q_1 are expressed in terms of the eigenvalues a_1 and a_2 .
24. The operators A , B and C are Hermitian. Given that $[A, C] = 0$, $[B, C] = 0$ and $[A, B] \neq 0$, show that C has at least one degenerate eigenvalue.

2.15 Solutions

1. Let

$$|\gamma\rangle = |u\rangle + \lambda |v\rangle , \quad (2.193)$$

where $\lambda \in \mathcal{C}$. The requirement $\langle \gamma | \gamma \rangle \geq 0$ leads to

$$\langle u | u \rangle + \lambda \langle u | v \rangle + \lambda^* \langle v | u \rangle + |\lambda|^2 \langle v | v \rangle \geq 0 . \quad (2.194)$$

By choosing

$$\lambda = -\frac{\langle v | u \rangle}{\langle v | v \rangle} , \quad (2.195)$$

one has

$$\langle u | u \rangle - \frac{\langle v | u \rangle}{\langle v | v \rangle} \langle u | v \rangle - \frac{\langle u | v \rangle}{\langle v | v \rangle} \langle v | u \rangle + \left| \frac{\langle v | u \rangle}{\langle v | v \rangle} \right|^2 \langle v | v \rangle \geq 0, \quad (2.196)$$

thus

$$|\langle u | v \rangle| \leq \sqrt{\langle u | u \rangle} \sqrt{\langle v | v \rangle}. \quad (2.197)$$

2. The following holds

$$\begin{aligned} (\langle u | + \langle v |) (|u\rangle + |v\rangle) &= \langle u | u \rangle + \langle v | v \rangle + 2 \operatorname{Re}(\langle u | v \rangle) \\ &\leq \langle u | u \rangle + \langle v | v \rangle + 2 |\langle u | v \rangle|. \end{aligned} \quad (2.198)$$

Thus, using Schwartz inequality one has

$$\begin{aligned} (\langle u | + \langle v |) (|u\rangle + |v\rangle) &\leq \langle u | u \rangle + \langle v | v \rangle + 2 \sqrt{\langle u | u \rangle} \sqrt{\langle v | v \rangle} \\ &= \left(\sqrt{\langle u | u \rangle} + \sqrt{\langle v | v \rangle} \right)^2. \end{aligned} \quad (2.199)$$

3. Since

$$1 = U^\dagger U = (1 - i\epsilon F^\dagger)(1 + i\epsilon F) = 1 + i\epsilon(F - F^\dagger) + O(\epsilon^2), \quad (2.200)$$

one has $F = F^\dagger$.

4. In general, $(|\beta\rangle \langle \alpha|)^\dagger = |\alpha\rangle \langle \beta|$, thus clearly the operator A is Hermitian. Moreover it is positive-definite since for every $|u\rangle$ the following holds

$$\langle u | A | u \rangle = \langle u | a \rangle \langle a | u \rangle = |\langle a | u \rangle|^2 \geq 0. \quad (2.201)$$

5. Let

$$|\gamma\rangle = |u\rangle - \frac{\langle v | A | u \rangle}{\langle v | A | v \rangle} |v\rangle.$$

Since A is Hermitian and positive-definite the following holds

$$\begin{aligned} 0 &\leq \langle \gamma | A | \gamma \rangle \\ &= \left(\langle u | - \frac{\langle u | A | v \rangle}{\langle v | A | v \rangle} \langle v | \right) A \left(|u\rangle - \frac{\langle v | A | u \rangle}{\langle v | A | v \rangle} |v\rangle \right) \\ &= \langle u | A | u \rangle - \frac{|\langle u | A | v \rangle|^2}{\langle v | A | v \rangle} - \frac{|\langle u | A | v \rangle|^2}{\langle v | A | v \rangle} + \frac{|\langle u | A | v \rangle|^2}{\langle v | A | v \rangle}, \end{aligned} \quad (2.202)$$

thus

$$|\langle u | A | v \rangle| \leq \sqrt{\langle u | A | u \rangle} \sqrt{\langle v | A | v \rangle}. \quad (2.203)$$

Note that this result allows easy proof of the following: Under the same conditions (namely, A is a Hermitian positive-definite operator) $\operatorname{Tr}(A) = 0$ if and only if $A = 0$.

6. Recall that the eigenvalues of a positive-definite operator are positive.

- a) The operator $C_1 = i[A, B]$ is Hermitian, hence the operator C_1^2 is positive-definite, and thus the following holds

$$0 \leq \text{Tr}(C_1^2) = \text{Tr}(-[A, B]^2), \quad (2.204)$$

where [see Eq. (2.134)]

$$\begin{aligned} \text{Tr}(-[A, B]^2) &= \text{Tr}(-ABAB + ABBA + BAAB - BABA) \\ &= 2\text{Tr}(A^2B^2 - (AB)^2), \end{aligned} \quad (2.205)$$

hence inequality (2.175) holds.

- b) The operator $C_2 = A - B$ is Hermitian, hence the operator C_2^2 is positive-definite, and thus the following holds

$$0 \leq \text{Tr}(C_2^2) = \text{Tr}((A - B)^2), \quad (2.206)$$

where [see Eq. (2.134)]

$$\text{Tr}((A - B)^2) = \text{Tr}(A^2 + B^2 - 2AB), \quad (2.207)$$

hence inequality (2.176) holds.

- c) The inequality (2.177) is obtained from inequality (2.176) by replacing the operators A and B by the operators $A' = A/\sqrt{\text{Tr}(A^2)}$ and $B' = B/\sqrt{\text{Tr}(B^2)}$, respectively [note that $\text{Tr}(A'^2) = \text{Tr}(B'^2) = 1$].

7. The expansion is given by

$$\begin{aligned} (A - \lambda B)^{-1} &= (A(1 - \lambda A^{-1}B))^{-1} \\ &= (1 - \lambda A^{-1}B)^{-1} A^{-1} \\ &= \left(1 + \lambda A^{-1}B + (\lambda A^{-1}B)^2 + (\lambda A^{-1}B)^3 + \dots\right) A^{-1}. \end{aligned} \quad (2.208)$$

8. By definition:

$$\begin{aligned} \frac{d}{d\lambda}(AB) &= \lim_{\epsilon \rightarrow 0} \frac{A(\lambda + \epsilon)B(\lambda + \epsilon) - A(\lambda)B(\lambda)}{\epsilon} \\ &= \lim_{\epsilon \rightarrow 0} \frac{(A(\lambda + \epsilon) - A(\lambda))B(\lambda)}{\epsilon} + \lim_{\epsilon \rightarrow 0} \frac{A(\lambda + \epsilon)(B(\lambda + \epsilon) - B(\lambda))}{\epsilon} \\ &= \frac{dA}{d\lambda}B + A\frac{dB}{d\lambda}. \end{aligned} \quad (2.209)$$

9. Taking the derivative of both sides of the identity $1 = AA^{-1}$ one has

$$0 = \frac{dA}{d\lambda}A^{-1} + A\frac{dA^{-1}}{d\lambda}, \quad (2.210)$$

thus

$$\frac{d}{d\lambda}(A^{-1}) = -A^{-1}\frac{dA}{d\lambda}A^{-1}. \quad (2.211)$$

10. Let $\{|n\rangle\}$ be a complete orthonormal basis, namely

$$\sum_n |n\rangle\langle n| = 1. \quad (2.212)$$

In this basis

$$\text{Tr}(|u\rangle\langle v|) = \sum_n \langle n|u\rangle\langle v|n\rangle = \langle v|\left(\sum_n |n\rangle\langle n|\right)|u\rangle = \langle v|u\rangle. \quad (2.213)$$

11. The operator $A^\dagger A$ is Hermitian since $(A^\dagger A)^\dagger = A^\dagger A$, and positive-definite since the norm of $A|u\rangle$ is nonnegative for every $|u\rangle$, thus one has $\langle u|A^\dagger A|u\rangle \geq 0$. Moreover, using a complete orthonormal basis $\{|n\rangle\}$ one has

$$\begin{aligned} \text{Tr}(A^\dagger A) &= \sum_n \langle n|A^\dagger A|n\rangle \\ &= \sum_{n,m} \langle n|A^\dagger|m\rangle\langle m|A|n\rangle \\ &= \sum_{n,m} |\langle m|A|n\rangle|^2. \end{aligned} \quad (2.214)$$

12. Let $\{|b'\rangle\}$ be a complete orthonormal basis made of eigenvectors of B (i.e., $B|b'\rangle = b'|b'\rangle$). Using this basis for evaluating the trace one has

$$\text{Tr}(AB) = \sum_{b'} \langle b'|AB|b'\rangle = \sum_{b'} \underbrace{b'}_{\geq 0} \underbrace{\langle b'|A|b'\rangle}_{\geq 0} \geq 0. \quad (2.215)$$

13. Let $f(s) = e^{sL}Ae^{-sL}$, where s is real. Using Taylor expansion one has

$$f(1) = f(0) + \frac{1}{1!} \left. \frac{df}{ds} \right|_{s=0} + \frac{1}{2!} \left. \frac{d^2f}{ds^2} \right|_{s=0} + \dots, \quad (2.216)$$

thus

$$e^L A e^{-L} = A + \frac{1}{1!} \left. \frac{df}{ds} \right|_{s=0} + \frac{1}{2!} \left. \frac{d^2f}{ds^2} \right|_{s=0} + \dots, \quad (2.217)$$

where

$$\frac{df}{ds} = Le^{sL}Ae^{-sL} - e^{sL}Ae^{-sL}L = [L, f(s)] , \quad (2.218)$$

$$\frac{d^2f}{ds^2} = \left[L, \frac{df}{ds} \right] = [L, [L, f(s)]] , \quad (2.219)$$

therefore

$$e^L A e^{-L} = A + [L, A] + \frac{1}{2!} [L, [L, A]] + \frac{1}{3!} [L, [L, [L, A]]] + \dots . \quad (2.220)$$

14. The identity clearly holds for the case $m = 1$. Moreover, assuming it holds for m , namely assuming that

$$[A^m, B] = mA^{m-1} [A, B] , \quad (2.221)$$

one has

$$\begin{aligned} [A^{m+1}, B] &= A[A^m, B] + [A, B]A^m \\ &= mA^m[A, B] + [A, B]A^m . \end{aligned} \quad (2.222)$$

It is easy to show that if $[[A, B], A] = 0$ then $[[A, B], A^m] = 0$, thus one concludes that

$$[A^{m+1}, B] = (m+1)A^m[A, B] . \quad (2.223)$$

15. Define the function $f(s) = e^{sA}e^{sB}$, where s is real. The following holds

$$\begin{aligned} \frac{df}{ds} &= Ae^{sA}e^{sB} + e^{sA}Be^{sB} \\ &= (A + e^{sA}Be^{-sA})e^{sA}e^{sB} \end{aligned}$$

Using Eq. (2.183) one has

$$\begin{aligned} e^{sA}B &= \sum_{m=0}^{\infty} \frac{(sA)^m}{m!} B \\ &= \sum_{m=0}^{\infty} \frac{s^m (BA^m + [A^m, B])}{m!} \\ &= \sum_{m=0}^{\infty} \frac{s^m (BA^m + mA^{m-1}[A, B])}{m!} \\ &= Be^{sA} + s \sum_{m=1}^{\infty} \frac{(sA)^{m-1}}{(m-1)!} [A, B] \\ &= Be^{sA} + se^{sA} [A, B] , \end{aligned} \quad (2.224)$$

thus

$$\begin{aligned} \frac{df}{ds} &= Ae^{sA}e^{sB} + Be^{sA}e^{sB} + se^{sA}[A, B]e^{sB} \\ &= (A + B + [A, B]s) f(s) . \end{aligned} \quad (2.225)$$

The above differential equation can be easily integrated since $[[A, B], A] = 0$ and $[[A, B], B] = 0$. Thus

$$f(s) = e^{(A+B)s} e^{[A, B] \frac{s^2}{2}} . \quad (2.226)$$

For $s = 1$ one gets

$$e^A e^B = e^{A+B} e^{(1/2)[A, B]} . \quad (2.227)$$

16. For complex numbers x and y the following holds

$$[\log(x + \epsilon y) - \log(x)] x = y\epsilon + O(\epsilon^2) , \quad (2.228)$$

hence Eq. (2.185) holds [see Eq. (2.134)].

17. Define

$$f(\beta) \equiv [A, e^{-\beta H}] , \quad (2.229)$$

$$g(\beta) \equiv e^{-\beta H} \int_0^\beta e^{\lambda H} [H, A] e^{-\lambda H} d\lambda . \quad (2.230)$$

Clearly, $f(0) = g(0) = 0$. Moreover, the following holds

$$\frac{df}{d\beta} = -AH e^{-\beta H} + H e^{-\beta H} A = -Hf + [H, A] e^{-\beta H} , \quad (2.231)$$

$$\frac{dg}{d\beta} = -Hg + [H, A] e^{-\beta H} , \quad (2.232)$$

namely, both functions satisfy the same differential equation. Therefore $f = g$.

18. The matrix elements of $[A_\rho, \log \rho]$ in the basis of the eigenvectors $|m\rangle$ of ρ , which satisfy $\rho|m\rangle = \rho_m|m\rangle$, where the real numbers ρ_m are the corresponding eigenvalues, are given by

$$\begin{aligned} &\langle m' | [A_\rho, \log \rho] | m'' \rangle \\ &= \langle m' | A | m'' \rangle \int_0^1 dq \left(\rho_{m'}^q \rho_{m''}^{1-q} \log \rho_{m''} - \log \rho_{m'} \rho_{m'}^q \rho_{m''}^{1-q} \right) \\ &= \langle m' | A | m'' \rangle (\rho_{m''} - \rho_{m'}) , \end{aligned} \quad (2.233)$$

hence Eq. (2.187) holds.

19. The following holds [see Eq. (2.179)]

$$\begin{aligned} \frac{d}{dt} e^{A(t)} &= \frac{d}{dt} \sum_{n=0}^{\infty} \frac{A^n}{n!} \\ &= \sum_{n=0}^{\infty} \sum_{m=0}^{n-1} \frac{1}{n!} A^m \frac{dA}{dt} A^{n-m-1}, \end{aligned} \quad (2.234)$$

thus

$$\frac{d}{dt} e^{A(t)} = \sum_{k=0}^{\infty} \sum_{l=0}^{\infty} \frac{1}{(k+l+1)!} A^k \frac{dA}{dt} A^l. \quad (2.235)$$

With the help of the identity

$$\frac{k!l!}{(k+l+1)!} = \int_0^1 d\eta \eta^k (1-\eta)^l, \quad (2.236)$$

this becomes

$$\begin{aligned} \frac{d}{dt} e^{A(t)} &= \sum_{k=0}^{\infty} \sum_{l=0}^{\infty} \frac{1}{k!l!} \int_0^1 d\eta \eta^k (1-\eta)^l A^k \frac{dA}{dt} A^l \\ &= \int_0^1 d\eta \sum_{k=0}^{\infty} \frac{(\eta A)^k}{k!} \frac{dA}{dt} \sum_{l=0}^{\infty} \frac{((1-\eta)A)^l}{l!} \\ &= \int_0^1 d\eta e^{\eta A} \frac{dA}{dt} e^{(1-\eta)A}. \end{aligned} \quad (2.237)$$

Alternatively, Eq. (2.189) can be derived by introducing the function $\mathcal{A}(\eta, t)$, which is defined by

$$\mathcal{A}(\eta, t) = \frac{\partial e^{\eta A(t)}}{\partial t} e^{-\eta A(t)}, \quad (2.238)$$

where both η and t are real. The following holds

$$\begin{aligned} \frac{\partial \mathcal{A}}{\partial \eta} &= \left(\frac{\partial}{\partial \eta} \frac{\partial}{\partial t} e^{\eta A} \right) e^{-\eta A} + \frac{\partial e^{\eta A}}{\partial t} \frac{\partial e^{-\eta A}}{\partial \eta} \\ &= \left(\frac{\partial}{\partial t} \frac{\partial}{\partial \eta} e^{\eta A} \right) e^{-\eta A} + \frac{\partial e^{\eta A}}{\partial t} \frac{\partial e^{-\eta A}}{\partial \eta} \\ &= \frac{\partial (e^{\eta A} A)}{\partial t} e^{-\eta A} - \frac{\partial e^{\eta A}}{\partial t} A e^{-\eta A} \\ &= \left(\frac{\partial e^{\eta A}}{\partial t} A + e^{\eta A} \frac{dA}{dt} \right) e^{-\eta A} - \frac{\partial e^{\eta A}}{\partial t} A e^{-\eta A} \\ &= e^{\eta A} \frac{dA}{dt} e^{-\eta A}. \end{aligned} \quad (2.239)$$

The above result together with the relation [see Eq. (2.238)]

$$\frac{de^A}{dt}e^{-A} = \mathcal{A}(1, 1) , \quad (2.240)$$

lead to [note that $\mathcal{A}(0, 1) = 0$]

$$\begin{aligned} \frac{d}{dt}e^{A(t)} &= \mathcal{A}(1, 1) e^A \\ &= \left(\mathcal{A}(0, 1) + \int_0^1 d\eta \frac{\partial \mathcal{A}}{\partial \eta} \right) e^A \\ &= \int_0^1 d\eta e^{\eta A} \frac{dA}{dt} e^{(1-\eta)A} . \end{aligned} \quad (2.241)$$

20. Using a complete orthonormal basis $\{|n\rangle\}$ one has

$$\begin{aligned} \text{Tr}(XY) &= \sum_n \langle n| XY |n\rangle \\ &= \sum_{n,m} \langle n| X |m\rangle \langle m| Y |n\rangle \\ &= \sum_{n,m} \langle m| Y |n\rangle \langle n| X |m\rangle \\ &= \sum_m \langle m| YX |m\rangle \\ &= \text{Tr}(YX) . \end{aligned} \quad (2.242)$$

Note that using this result it is easy to show that $\text{Tr}(U^+ X U) = \text{Tr}(X)$, provided that U is a unitary operator.

21. Clearly A is Hermitian, namely $A^\dagger = A$, thus the two eigenvalues λ_1 and λ_2 are expected to be real. Since the trace of an operator is basis independent, the following must hold

$$\text{Tr}(A) = \lambda_1 + \lambda_2 , \quad (2.243)$$

and

$$\text{Tr}(A^2) = \lambda_1^2 + \lambda_2^2 . \quad (2.244)$$

On the other hand, with the help of Eq. (2.181) one finds that

$$\text{Tr}(A) = \text{Tr}(|\alpha\rangle \langle \alpha|) - \text{Tr}(|\beta\rangle \langle \beta|) = 0 , \quad (2.245)$$

and

$$\begin{aligned}
\text{Tr}(A^2) &= \text{Tr}(|\alpha\rangle\langle\alpha| |\alpha\rangle\langle\alpha|) + \text{Tr}(|\beta\rangle\langle\beta| |\beta\rangle\langle\beta|) \\
&\quad - \text{Tr}(|\alpha\rangle\langle\alpha| |\beta\rangle\langle\beta|) - \text{Tr}(|\beta\rangle\langle\beta| |\alpha\rangle\langle\alpha|) \\
&= 2 - \langle\alpha|\beta\rangle \text{Tr}(|\alpha\rangle\langle\beta|) - \langle\beta|\alpha\rangle \text{Tr}(|\beta\rangle\langle\alpha|) \\
&= 2 \left(1 - |\langle\alpha|\beta\rangle|^2\right),
\end{aligned} \tag{2.246}$$

thus

$$\lambda_{\pm} = \pm \sqrt{1 - |\langle\alpha|\beta\rangle|^2}. \tag{2.247}$$

Alternatively, this problem can also be solved as follows. In general, the state $|\beta\rangle$ can be decomposed into a parallel to and a perpendicular to $|\alpha\rangle$ terms, namely

$$|\beta\rangle = a|\alpha\rangle + c|\gamma\rangle, \tag{2.248}$$

where $a, c \in \mathcal{C}$, the vector $|\gamma\rangle$ is orthogonal to $|\alpha\rangle$, namely $\langle\gamma|\alpha\rangle = 0$, and in addition $|\gamma\rangle$ is assumed to be normalized, namely $\langle\gamma|\gamma\rangle = 1$. Since $|\beta\rangle$ is normalized one has $|a|^2 + |c|^2 = 1$. The matrix representation of A in the orthonormal basis $\{|\alpha\rangle, |\gamma\rangle\}$ is given by

$$A \doteq \begin{pmatrix} \langle\alpha|A|\alpha\rangle & \langle\alpha|A|\gamma\rangle \\ \langle\gamma|A|\alpha\rangle & \langle\gamma|A|\gamma\rangle \end{pmatrix} = \begin{pmatrix} |c|^2 & -ac^* \\ -a^*c & -|c|^2 \end{pmatrix} \equiv \hat{A}. \tag{2.249}$$

Thus,

$$\text{Tr}(\hat{A}) = 0, \tag{2.250}$$

and

$$\text{Det}(\hat{A}) = -|c|^2(|c|^2 + |a|^2) = -\left(1 - |\langle\alpha|\beta\rangle|^2\right), \tag{2.251}$$

therefore the eigenvalues are

$$\lambda_{\pm} = \pm \sqrt{1 - |\langle\alpha|\beta\rangle|^2}. \tag{2.252}$$

22. Consider a solution having the form

$$|k\rangle = \sum_{n=0}^{N-1} e^{ink} |\varphi_n\rangle, \tag{2.253}$$

for which the eigenvalue equation given by

$$\mathcal{H}|k\rangle = E_k|k\rangle, \tag{2.254}$$

yields

$$\begin{aligned}
 & E_0 \sum_{n=0}^{N-1} |\varphi_n\rangle \langle \varphi_n| \sum_{m=0}^{N-1} e^{imk} |\varphi_m\rangle \\
 & - a \sum_{n=0}^{N-1} \left(|\varphi_n\rangle \langle \varphi_{(n+1)'}| + |\varphi_n\rangle \langle \varphi_{(n-1)'}| \right) \sum_{m=0}^{N-1} e^{imk} |\varphi_m\rangle \\
 & = E_k \sum_{m=0}^{N-1} e^{imk} |\varphi_m\rangle ,
 \end{aligned} \tag{2.255}$$

thus (recall that $\langle \varphi_n | \varphi_m \rangle = \delta_{n,m}$)

$$\sum_{n=0}^{N-1} \left[E_0 - E_k - a \left(e^{i((n+1)'-n)k} + e^{i((n-1)'-n)k} \right) \right] e^{ink} |\varphi_n\rangle = 0 . \tag{2.256}$$

A solution is obtained provided that the term $\left(e^{i((n+1)'-n)k} + e^{i((n-1)'-n)k} \right)$ is independent on n . This condition is satisfied when

$$e^{iNk} = 1 . \tag{2.257}$$

For this case the following holds for all n

$$e^{i((n+1)'-n)k} + e^{i((n-1)'-n)k} = e^{ik} + e^{-ik} = 2 \cos k . \tag{2.258}$$

The m 'th solution of $e^{iNk} = 1$ is denoted by k_m , which is given by

$$k_m = \frac{2\pi m}{N} , \tag{2.259}$$

where $m = 0, 1, \dots, N-1$, and the corresponding eigenvalue E_k is given by $E(k_m)$, where

$$E(k) = E_0 - 2a \cos k . \tag{2.260}$$

23. The following holds

$$A = P_1 a_1 + P_2 a_2 , \tag{2.261}$$

and

$$f(A) = P_1 f(a_1) + P_2 f(a_2) , \tag{2.262}$$

where the projection operators P_1 and P_2 are given by [see Eq. (2.80)]

$$P_1 = \frac{A - a_2}{a_1 - a_2} , \tag{2.263}$$

$$P_2 = \frac{A - a_1}{a_2 - a_1} . \tag{2.264}$$

a) Using Eqs. (2.262), (2.263) and (2.264) one finds that

$$f(A) = \frac{A - a_2}{a_1 - a_2} f(a_1) + \frac{A - a_1}{a_2 - a_1} f(a_2) . \quad (2.265)$$

b) For this case Eq. (2.265) yields

$$\begin{aligned} A^2 &= \frac{A - a_2}{a_1 - a_2} a_1^2 + \frac{A - a_1}{a_2 - a_1} a_2^2 \\ &= (a_1 + a_2) A - a_1 a_2 . \end{aligned} \quad (2.266)$$

24. In the basis of eigenvectors of C , the matrix representation of C is diagonal, and the matrices of both A and B have block form [see Eq. (2.152)]. The block corresponding to the n 'th eigenvalue of C has size $g_n \times g_n$, where g_n is the degree of degeneracy of the n 'th eigenvalue. The assumption that $g_n = 1$ for all n values implies that $[A, B] = 0$, thus C has at least one degenerate eigenvalue (since it is given that $[A, B] \neq 0$).

3. The Position and Momentum Observables

Consider a point particle moving in a 3 dimensional space. We first treat the system classically. The position of the particle is described using the Cartesian coordinates q_x , q_y and q_z . Let

$$p_j = \frac{\partial \mathcal{L}}{\partial \dot{q}_j} \quad (3.1)$$

be the canonically conjugate variable to the coordinate q_j , where $j \in \{x, y, z\}$ and where \mathcal{L} is the Lagrangian. As we have seen in exercise 3 of set 1, the following Poisson's brackets relations hold

$$\{q_j, q_k\} = 0, \quad (3.2)$$

$$\{p_j, p_k\} = 0, \quad (3.3)$$

$$\{q_j, p_k\} = \delta_{jk}. \quad (3.4)$$

In quantum mechanics, each of the 6 variables q_x , q_y , q_z , p_x , p_y and p_z is represented by an Hermitian operator, namely by an observable. It is postulated that the commutation relations between each pair of these observables is related to the corresponding Poisson's brackets according to the rule

$$\{, \} \rightarrow \frac{1}{i\hbar} [,] . \quad (3.5)$$

Namely the following is postulated to hold

$$[q_j, q_k] = 0, \quad (3.6)$$

$$[p_j, p_k] = 0, \quad (3.7)$$

$$[q_j, p_k] = i\hbar\delta_{jk}. \quad (3.8)$$

Note that here we use the same notation for a classical variable and its quantum observable counterpart. In this chapter we will derive some results that are solely based on Eqs. (3.6), (3.7) and (3.8).

3.1 The One-Dimensional Case

In this section, which deals with the relatively simple case of a one-dimensional motion of a point particle, we employ the less cumbersome notation x and

p for the observables q_x and p_x . The commutation relation between these operators is given by [see Eq. (3.8)]

$$[x, p] = i\hbar . \quad (3.9)$$

The uncertainty principle (2.160) employed for x and p yields

$$\langle (\Delta x)^2 \rangle \langle (\Delta p)^2 \rangle \geq \frac{\hbar^2}{4} . \quad (3.10)$$

3.1.1 Position Representation

Let x' be an eigenvalue of the observable x , and let $|x'\rangle$ be the corresponding eigenvector, namely

$$x|x'\rangle = x'|x'\rangle . \quad (3.11)$$

Note that $x' \in \mathcal{R}$ since x is Hermitian. As we will see below transformation between different eigenvectors $|x'\rangle$ can be performed using the translation operator $J(\Delta_x)$.

Definition 3.1.1. *The translation operator is given by*

$$J(\Delta_x) = \exp\left(-\frac{i\Delta_x p}{\hbar}\right) , \quad (3.12)$$

where $\Delta_x \in \mathcal{R}$.

Recall that in general the meaning of a function of an operator can be understood in terms of the Taylor expansion of the function, that is, for the present case

$$J(\Delta_x) = \sum_{n=0}^{\infty} \frac{1}{n!} \left(-\frac{i\Delta_x p}{\hbar}\right)^n . \quad (3.13)$$

It is easy to show that $J(\Delta_x)$ is unitary

$$J^\dagger(\Delta_x) = J(-\Delta_x) = J^{-1}(\Delta_x) . \quad (3.14)$$

Moreover, the following composition property holds

$$J(\Delta_{x1}) J(\Delta_{x2}) = J(\Delta_{x1} + \Delta_{x2}) . \quad (3.15)$$

Theorem 3.1.1. *Let x' be an eigenvalue of the observable x , and let $|x'\rangle$ be the corresponding eigenvector. Then the ket-vector $J(\Delta_x)|x'\rangle$ is a normalized eigenvector of x with an eigenvalue $x' + \Delta_x$.*

Proof. With the help of Eq. (3.77), which is given by

$$[x, B(p)] = i\hbar \frac{dB}{dp}, \quad (3.16)$$

and which is proven in exercise 1 of set 3, one finds that

$$[x, J(\Delta_x)] = i\hbar \frac{\Delta_x}{i\hbar} J(\Delta_x). \quad (3.17)$$

Using this result one has

$$xJ(\Delta_x)|x'\rangle = ([x, J(\Delta_x)] + J(\Delta_x)x)|x'\rangle = (x' + \Delta_x)J(\Delta_x)|x'\rangle, \quad (3.18)$$

thus the ket-vector $J(\Delta_x)|x'\rangle$ is an eigenvector of x with an eigenvalue $x' + \Delta_x$. Moreover, $J(\Delta_x)|x'\rangle$ is normalized since J is unitary.

In view of the above theorem we will in what follows employ the notation

$$J(\Delta_x)|x'\rangle = |x' + \Delta_x\rangle. \quad (3.19)$$

An important consequence of the last result is that the spectrum of eigenvalues of the operator x is continuous and contains all real numbers. This point will be further discussed below.

The position *wavefunction* $\psi_\alpha(x')$ of a state vector $|\alpha\rangle$ is defined as:

$$\psi_\alpha(x') = \langle x' | \alpha \rangle. \quad (3.20)$$

Given the wavefunction $\psi_\alpha(x')$ of a state vector $|\alpha\rangle$, what is the wavefunction of the state $O|\alpha\rangle$, where O is an operator? We will answer this question below for some cases:

1. The operator $O = x$. In this case

$$\langle x' | x | \alpha \rangle = x' \langle x' | \alpha \rangle = x' \psi_\alpha(x'), \quad (3.21)$$

namely, the desired wavefunction is obtained by multiplying $\psi_\alpha(x')$ by x' .

2. The operator O is a function $A(x)$ of the operator x . Let

$$A(x) = \sum_n a_n x^n. \quad (3.22)$$

be the Taylor expansion of $A(x)$. Exploiting the fact that x is Hermitian one finds that

$$\langle x' | A(x) | \alpha \rangle = \sum_n a_n \underbrace{\langle x' | x^n | \alpha \rangle}_{x'^n \langle x' | \alpha \rangle} = \sum_n a_n x'^n \langle x' | \alpha \rangle = A(x') \psi_\alpha(x'). \quad (3.23)$$

3. The operator $O = J(\Delta_x)$. In this case

$$\langle x' | J(\Delta_x) | \alpha \rangle = \langle x' | J^\dagger(-\Delta_x) | \alpha \rangle = \langle x' - \Delta_x | \alpha \rangle = \psi_\alpha(x' - \Delta_x) . \quad (3.24)$$

4. The operator $O = p$. In view of Eq. (3.12), the following holds

$$J(-\Delta_x) = \exp\left(\frac{ip\Delta_x}{\hbar}\right) = 1 + \frac{i\Delta_x}{\hbar}p + O\left((\Delta_x)^2\right) , \quad (3.25)$$

thus

$$\langle x' | J(-\Delta_x) | \alpha \rangle = \psi_\alpha(x') + \frac{i\Delta_x}{\hbar} \langle x' | p | \alpha \rangle + O\left((\Delta_x)^2\right) . \quad (3.26)$$

On the other hand, according to Eq. (3.24) also the following holds

$$\langle x' | J(-\Delta_x) | \alpha \rangle = \psi_\alpha(x' + \Delta_x) . \quad (3.27)$$

Equating the above two expressions for $\langle x' | J(-\Delta_x) | \alpha \rangle$ yields

$$\langle x' | p | \alpha \rangle = -i\hbar \frac{\psi_\alpha(x' + \Delta_x) - \psi_\alpha(x')}{\Delta_x} + O(\Delta_x) . \quad (3.28)$$

Thus, in the limit $\Delta_x \rightarrow 0$ one has

$$\langle x' | p | \alpha \rangle = -i\hbar \frac{d\psi_\alpha}{dx'} . \quad (3.29)$$

To mathematically understand the last result, consider the differential operator

$$\begin{aligned} \tilde{J}(-\Delta_x) &= \exp\left(\Delta_x \frac{d}{dx}\right) \\ &= 1 + \Delta_x \frac{d}{dx} + \frac{1}{2!} \left(\Delta_x \frac{d}{dx}\right)^2 + \dots . \end{aligned} \quad (3.30)$$

In view of the Taylor expansion of an arbitrary function $f(x)$

$$\begin{aligned} f(x_0 + \Delta_x) &= f(x_0) + \Delta_x \frac{df}{dx} + \frac{(\Delta_x)^2}{2!} \frac{d^2f}{dx^2} + \dots \\ &= \exp\left(\Delta_x \frac{d}{dx}\right) f \Big|_{x=x_0} \\ &= \tilde{J}(-\Delta_x) f \Big|_{x=x_0} , \end{aligned} \quad (3.31)$$

one can argue that the operator $\tilde{J}(-\Delta_x)$ generates translation.

As we have pointed out above, the spectrum (i.e., the set of all eigenvalues) of x is continuous. On the other hand, in the discussion in chapter 2 only the case of an observable having discrete spectrum has been considered. Rigorous mathematical treatment of the case of continuous spectrum is nontrivial mainly because typically the eigenvectors in such a case cannot be normalized. However, under some conditions one can generalize some of the results given in chapter 2 for the case of an observable having a continuous spectrum. These generalization is demonstrated below for the case of the position operator x :

1. The closure relation (2.23) is written in terms of the eigenvectors $|x'\rangle$ as

$$\int_{-\infty}^{\infty} dx' |x'\rangle \langle x'| = 1, \quad (3.32)$$

namely, the discrete sum is replaced by an integral.

2. With the help of Eq. (3.32) an arbitrary ket-vector can be written as

$$|\alpha\rangle = \int_{-\infty}^{\infty} dx' |x'\rangle \langle x' | \alpha \rangle = \int_{-\infty}^{\infty} dx' \psi_{\alpha}(x') |x'\rangle, \quad (3.33)$$

and the inner product between a ket-vector $|\alpha\rangle$ and a bra-vector $\langle\beta|$ as

$$\langle\beta | \alpha\rangle = \int_{-\infty}^{\infty} dx' \langle\beta | x'\rangle \langle x' | \alpha\rangle = \int_{-\infty}^{\infty} dx' \psi_{\beta}^*(x') \psi_{\alpha}(x'). \quad (3.34)$$

3. The normalization condition reads

$$1 = \langle\alpha | \alpha\rangle = \int_{-\infty}^{\infty} dx' |\psi_{\alpha}(x')|^2. \quad (3.35)$$

4. The orthonormality relation (2.65) is written in the present case as

$$\langle x'' | x'\rangle = \delta(x' - x''). \quad (3.36)$$

Note that the above orthonormality relation (3.36) is consistent with the closure relation (3.32). This can be seen by evaluating the operator $1^2 = 1 \times 1$ using Eqs. (3.32) and (3.36)

$$1^2 = \int_{-\infty}^{\infty} dx' \int_{-\infty}^{\infty} dx'' |x''\rangle \underbrace{\langle x'' | x'\rangle}_{\delta(x' - x'')} \langle x'| = \int_{-\infty}^{\infty} dx' |x'\rangle \langle x'|, \quad (3.37)$$

thus, as expected $1^2 = 1$.

5. In a measurement of the observable x , the quantity

$$f(x') = |\langle x' | \alpha \rangle|^2 = |\psi_\alpha(x')|^2 \quad (3.38)$$

represents the probability distribution function to find the particle at the point $x = x'$.

6. That is, the probability to find the particle in the interval (x_1, x_2) is given by

$$p_{(x_1, x_2)} = \int_{x_1}^{x_2} dx' f(x') . \quad (3.39)$$

This can be rewritten as

$$p_{(x_1, x_2)} = \langle \alpha | P_{(x_1, x_2)} | \alpha \rangle , \quad (3.40)$$

where the projection operator $P_{(x_1, x_2)}$ is given by

$$P_{(x_1, x_2)} = \int_{x_1}^{x_2} dx' |x'\rangle \langle x'| . \quad (3.41)$$

The operator $P_{(x_1, x_2)}$ is considered to be a projection operator since for every $x_0 \in (x_1, x_2)$ the following holds

$$P_{(x_1, x_2)} |x_0\rangle = \int_{x_1}^{x_2} dx' |x'\rangle \underbrace{\langle x' | x_0 \rangle}_{\delta(x' - x_0)} = |x_0\rangle . \quad (3.42)$$

7. Any realistic measurement of a continuous variable such as position is subjected to finite resolution. Assuming that a particle has been measured to be located in the interval $(x' - \delta_x/2, x' + \delta_x/2)$, where δ_x is the resolution of the measuring device, the collapse postulate implies that the state of the system undergoes the following transformation

$$|\alpha\rangle \rightarrow \frac{P_{(x' - \delta_x/2, x' + \delta_x/2)} |\alpha\rangle}{\sqrt{\langle \alpha | P_{(x' - \delta_x/2, x' + \delta_x/2)} | \alpha \rangle}} . \quad (3.43)$$

8. Some observables have a mixed spectrum containing both a discrete and continuous subsets. An example of such a mixed spectrum is the set of eigenvalues of the Hamiltonian operator of a potential well of finite depth.

3.1.2 Momentum Representation

Let p' be an eigenvalue of the observable p , and let $|p'\rangle$ be the corresponding eigenvector, namely

$$p |p'\rangle = p' |p'\rangle . \quad (3.44)$$

Note that $p' \in \mathcal{R}$ since p is Hermitian. Similarly to the case of the position observable, the closure relation is written as

$$\int dp' |p'\rangle \langle p'| = 1, \quad (3.45)$$

and the orthonormality relation as

$$\langle p'' | p'\rangle = \delta(p' - p''). \quad (3.46)$$

The momentum *wavefunction* $\phi_\alpha(p')$ of a given state $|\alpha\rangle$ is defined as

$$\phi_\alpha(p') = \langle p' | \alpha\rangle. \quad (3.47)$$

The probability distribution function to measure a momentum value of $p = p'$ is

$$|\phi_\alpha(p')|^2 = |\langle p' | \alpha\rangle|^2. \quad (3.48)$$

Any ket-vector can be decomposed into momentum eigenstates as

$$|\alpha\rangle = \int_{-\infty}^{\infty} dp' |p'\rangle \langle p' | \alpha\rangle = \int_{-\infty}^{\infty} dp' \phi_\alpha(p') |p'\rangle. \quad (3.49)$$

The inner product between a ket-vector $|\alpha\rangle$ and a bra-vector $\langle\beta|$ can be expressed as

$$\langle\beta | \alpha\rangle = \int_{-\infty}^{\infty} dp' \langle\beta | p'\rangle \langle p' | \alpha\rangle = \int_{-\infty}^{\infty} dp' \phi_\beta^*(p') \phi_\alpha(p'). \quad (3.50)$$

The normalization condition reads

$$1 = \langle\alpha | \alpha\rangle = \int_{-\infty}^{\infty} dp' |\phi_\alpha(p')|^2. \quad (3.51)$$

3.2 Transformation Function

What is the relation between the position wavefunction $\psi_\alpha(x')$ and its momentum counterpart $\phi_\alpha(p')$?

Claim. The transformation function $\langle x' | p'\rangle$ is given by

$$\langle x' | p'\rangle = \frac{1}{\sqrt{2\pi\hbar}} \exp\left(\frac{ip'x'}{\hbar}\right). \quad (3.52)$$

Proof. On one hand, according to Eq. (3.44)

$$\langle x' | p | p' \rangle = p' \langle x' | p' \rangle, \quad (3.53)$$

and on the other hand, according to Eq. (3.29)

$$\langle x' | p | p' \rangle = -i\hbar \frac{\partial}{\partial x'} \langle x' | p' \rangle, \quad (3.54)$$

thus

$$p' \langle x' | p' \rangle = -i\hbar \frac{\partial}{\partial x'} \langle x' | p' \rangle. \quad (3.55)$$

The general solution of this differential equation is

$$\langle x' | p' \rangle = N \exp\left(\frac{ip'x'}{\hbar}\right), \quad (3.56)$$

where N is a normalization constant. To determine the constant N we employ Eqs. (3.36) and (3.45):

$$\begin{aligned} & \delta(x' - x'') \\ &= \langle x' | x'' \rangle \\ &= \int dp' \langle x' | p' \rangle \langle p' | x'' \rangle \\ &= \int_{-\infty}^{\infty} dp' |N|^2 \exp\left(\frac{ip'(x' - x'')}{\hbar}\right) \\ &= \hbar |N|^2 \underbrace{\int_{-\infty}^{\infty} dk e^{ik(x' - x'')} }_{2\pi\delta(x' - x'')}. \end{aligned} \quad (3.57)$$

Thus, by choosing N to be real one finds that

$$\langle x' | p' \rangle = \frac{1}{\sqrt{2\pi\hbar}} \exp\left(\frac{ip'x'}{\hbar}\right). \quad (3.58)$$

The last result together with Eqs. (3.32) and (3.45) yield

$$\psi_{\alpha}(x') = \langle x' | \alpha \rangle = \int_{-\infty}^{\infty} dp' \langle x' | p' \rangle \langle p' | \alpha \rangle = \frac{\int_{-\infty}^{\infty} dp' e^{\frac{ip'x'}{\hbar}} \phi_{\alpha}(p')}{\sqrt{2\pi\hbar}}, \quad (3.59)$$

$$\phi_{\alpha}(p') = \langle p' | \alpha \rangle = \int_{-\infty}^{\infty} dx' \langle p' | x' \rangle \langle x' | \alpha \rangle = \frac{\int_{-\infty}^{\infty} dx' e^{-\frac{ip'x'}{\hbar}} \psi_{\alpha}(x')}{\sqrt{2\pi\hbar}}. \quad (3.60)$$

That is, transformations relating $\psi_{\alpha}(x')$ and $\phi_{\alpha}(p')$ are the direct and inverse Fourier transformations.

3.3 Generalization for 3D

According to Eq. (3.6) the observables q_x , q_y and q_z commute with each other, hence, a simultaneous diagonalization is possible. Denoting the common eigenvectors as

$$|\mathbf{r}'\rangle = |q'_x, q'_y, q'_z\rangle, \quad (3.61)$$

one has

$$q_x |\mathbf{r}'\rangle = q'_x |q'_x, q'_y, q'_z\rangle, \quad (3.62)$$

$$q_y |\mathbf{r}'\rangle = q'_y |q'_x, q'_y, q'_z\rangle, \quad (3.63)$$

$$q_z |\mathbf{r}'\rangle = q'_z |q'_x, q'_y, q'_z\rangle. \quad (3.64)$$

The closure relation is written as

$$1 = \int_{-\infty}^{\infty} \int_{-\infty}^{\infty} \int_{-\infty}^{\infty} dq'_x dq'_y dq'_z |\mathbf{r}'\rangle \langle \mathbf{r}'|, \quad (3.65)$$

and the orthonormality relation as

$$\langle \mathbf{r}' | \mathbf{r}'' \rangle = \delta(\mathbf{r}' - \mathbf{r}''). \quad (3.66)$$

Similarly, according to Eq. (3.7) the observables p_x , p_y and p_z commute with each other, hence, a simultaneous diagonalization is possible. Denoting the common eigenvectors as

$$|\mathbf{p}'\rangle = |p'_x, p'_y, p'_z\rangle, \quad (3.67)$$

one has

$$p_x |\mathbf{p}'\rangle = p'_x |p'_x, p'_y, p'_z\rangle, \quad (3.68)$$

$$p_y |\mathbf{p}'\rangle = p'_y |p'_x, p'_y, p'_z\rangle, \quad (3.69)$$

$$p_z |\mathbf{p}'\rangle = p'_z |p'_x, p'_y, p'_z\rangle. \quad (3.70)$$

The closure relation is written as

$$1 = \int_{-\infty}^{\infty} \int_{-\infty}^{\infty} \int_{-\infty}^{\infty} dp'_x dp'_y dp'_z |\mathbf{p}'\rangle \langle \mathbf{p}'|, \quad (3.71)$$

and the orthonormality relation as

$$\langle \mathbf{p}' | \mathbf{p}'' \rangle = \delta(\mathbf{p}' - \mathbf{p}''). \quad (3.72)$$

The translation operator in three dimensions can be expressed as

$$J(\Delta) = \exp\left(-\frac{i\Delta \cdot \mathbf{p}}{\hbar}\right), \quad (3.73)$$

where $\Delta = (\Delta_x, \Delta_y, \Delta_z) \in \mathcal{R}^3$, and where

$$J(\Delta) |\mathbf{r}'\rangle = |\mathbf{r}' + \Delta\rangle . \quad (3.74)$$

The generalization of Eq. (3.52) for three dimensions is

$$\langle \mathbf{r}' | \mathbf{p}' \rangle = \frac{1}{(2\pi\hbar)^{3/2}} \exp\left(\frac{i\mathbf{p}' \cdot \mathbf{r}'}{\hbar}\right) . \quad (3.75)$$

3.4 Problems

1. Let x and p be two $N \times N$ matrices, where $N > 0$ is a finite integer. Is it possible that $[x, p] = i\hbar$?
2. Show that

$$[p, A(x)] = -i\hbar \frac{dA}{dx} , \quad (3.76)$$

$$[x, B(p)] = i\hbar \frac{dB}{dp} , \quad (3.77)$$

where $A(x)$ is a differentiable function of x and $B(p)$ is a differentiable function of p .

3. Show that the mean value of x in a state described by the wavefunction $\psi(x)$, namely

$$\langle x \rangle = \int_{-\infty}^{+\infty} dx \psi^*(x) x \psi(x) , \quad (3.78)$$

is equal to the value of a for which the expression

$$F(a) \equiv \int_{-\infty}^{+\infty} dx \psi^*(x+a) x^2 \psi(x+a) \quad (3.79)$$

obtains a minimum, and that this minimum has the value

$$F_{\min} = (\Delta x)^2 = \langle x^2 \rangle - \langle x \rangle^2 . \quad (3.80)$$

4. Consider a Gaussian wave packet, whose x space wavefunction is given by

$$\psi_\alpha(x') = \frac{1}{\pi^{1/4} \sqrt{d}} \exp\left(ikx' - \frac{x'^2}{2d^2}\right) . \quad (3.81)$$

Calculate

$$\text{a) } \langle (\Delta x)^2 \rangle \langle (\Delta p)^2 \rangle$$

b) $\langle p' | \alpha \rangle$

5. Show that for the state $|\alpha\rangle$ with wave function

$$\langle x' | \alpha \rangle = \begin{cases} 1/\sqrt{2a} & \text{for } |x| \leq a \\ 0 & \text{for } |x| > a \end{cases}, \quad (3.82)$$

where $a > 0$, the uncertainty in momentum is infinity.

6. Show that

$$p = -i\hbar \int_{-\infty}^{\infty} dx' |x'\rangle \frac{d}{dx'} \langle x'|. \quad (3.83)$$

7. Show that

$$\frac{1}{(2\pi\hbar)^3} \int d^3\mathbf{p}' \exp\left(\frac{i\mathbf{p}' \cdot (\mathbf{r}' - \mathbf{r}'')}{\hbar}\right) = \delta(\mathbf{r}' - \mathbf{r}''). \quad (3.84)$$

8. Find eigenvectors and corresponding eigenvalues of the operator

$$O = p + Kx, \quad (3.85)$$

where K is a real constant, p is the momentum operator, which is canonically conjugate to the position operator x . Calculate the wavefunction of the eigenvectors.

9. Let $|\alpha\rangle$ be the state vector of a point particle having mass m that moves in one dimension along the x axis. The operator p_α is defined by the following requirements: (1) p_α is Hermitian (i.e. $p_\alpha^\dagger = p_\alpha$) (2) $[x, p_\alpha] = 0$ (i.e. p_α commutes with the position operator x) and (3)

$$\langle \alpha | (p - p_\alpha)^2 | \alpha \rangle = \min_O \langle \alpha | (p - O)^2 | \alpha \rangle, \quad (3.86)$$

where p is the momentum operator (i.e. the minimum value of the quantity $\langle \alpha | (p - O)^2 | \alpha \rangle$ is obtained when the operator O is chosen to be p_α).

- Calculate the matrix elements $\langle x' | p_\alpha | x'' \rangle$ of the operator p_α in the position representation.
- The operator \mathcal{P} is the difference between the 'true' momentum operator and p_α

$$\mathcal{P} = p - p_\alpha. \quad (3.87)$$

Calculate the variance $\langle (\Delta\mathcal{P})^2 \rangle$ with respect to the state $|\alpha\rangle$

$$\langle (\Delta\mathcal{P})^2 \rangle = \langle \alpha | \mathcal{P}^2 | \alpha \rangle - \langle \alpha | \mathcal{P} | \alpha \rangle^2. \quad (3.88)$$

c) Use your results to prove the uncertainty relation (3.10)

$$\langle (\Delta x)^2 \rangle \langle (\Delta p)^2 \rangle \geq \frac{\hbar^2}{4} . \quad (3.89)$$

where

$$\langle (\Delta x)^2 \rangle = \langle \alpha | x^2 | \alpha \rangle - \langle \alpha | x | \alpha \rangle^2 , \quad (3.90)$$

and where

$$\langle (\Delta p)^2 \rangle = \langle \alpha | p^2 | \alpha \rangle - \langle \alpha | p | \alpha \rangle^2 . \quad (3.91)$$

10. Consider a point particle moving in one dimension. Express the wavefunction of $\exp(i\hbar^{-1}axp) |\alpha\rangle$ in terms of the wavefunction $\psi_\alpha(x') = \langle x' | \alpha \rangle$ of the given state vector $|\alpha\rangle$, where x is the position operator, p is the momentum operator, and a is a real constant.
11. Let $\psi_\alpha(x') = \langle x' | \alpha \rangle$ be the position wavefunction of a given particle moving in one dimension having state vector $|\alpha\rangle$. Calculate the wavefunction of $p^{-1} |\alpha\rangle$, where p is the momentum operator.

3.5 Solutions

1. The following holds $\text{Tr}[x, p] = \text{Tr}(xp) - \text{Tr}(px) = 0$ [see Eq. (2.134)], hence the condition $[x, p] = i\hbar$ cannot be satisfied.
2. The commutator $[x, p] = i\hbar$ is a constant, thus the relation (2.183) can be employed

$$[p, x^m] = -i\hbar m x^{m-1} = -i\hbar \frac{dx^m}{dx} , \quad (3.92)$$

$$[x, p^m] = i\hbar m p^{m-1} = i\hbar \frac{dp^m}{dp} . \quad (3.93)$$

This holds for any m , thus, for any differentiable function $A(x)$ of x and for any differentiable function $B(p)$ of p one has

$$[p, A(x)] = -i\hbar \frac{dA}{dx} , \quad (3.94)$$

$$[x, B(p)] = i\hbar \frac{dB}{dp} . \quad (3.95)$$

3. The following holds

$$\begin{aligned}
F(a) &= \int_{-\infty}^{+\infty} dx \psi^*(x+a) x^2 \psi(x+a) \\
&= \int_{-\infty}^{+\infty} dx' \psi^*(x') (x' - a)^2 \psi(x') \\
&= \langle (x - a)^2 \rangle \\
&= \langle x^2 \rangle - 2a \langle x \rangle + a^2 .
\end{aligned} \tag{3.96}$$

The requirement

$$\frac{dF}{da} = 0 \tag{3.97}$$

leads to $-2 \langle x \rangle + 2a = 0$, or $a = \langle x \rangle$. At that point one has

$$F_{\min} = \langle (x - \langle x \rangle)^2 \rangle = \langle x^2 \rangle - \langle x \rangle^2 . \tag{3.98}$$

4. The following hold

$$\begin{aligned}
\langle x \rangle &= \int_{-\infty}^{+\infty} dx' \psi_\alpha^*(x') x' \psi_\alpha(x') \\
&= \frac{1}{\pi^{1/2} d} \int_{-\infty}^{+\infty} dx' \exp\left(-\frac{x'^2}{d^2}\right) x' \\
&= 0 ,
\end{aligned} \tag{3.99}$$

$$\begin{aligned}
\langle x^2 \rangle &= \int_{-\infty}^{+\infty} dx' \psi_\alpha^*(x') x'^2 \psi_\alpha(x') \\
&= \frac{1}{\pi^{1/2} d} \int_{-\infty}^{+\infty} dx' \exp\left(-\frac{x'^2}{d^2}\right) x'^2 \\
&= \frac{1}{\pi^{1/2} d} \frac{d^3 \pi^{1/2}}{2} \\
&= \frac{d^2}{2} ,
\end{aligned} \tag{3.100}$$

$$\begin{aligned}
 \langle p \rangle &= -i\hbar \int_{-\infty}^{+\infty} dx' \psi_{\alpha}^*(x') \frac{d\psi_{\alpha}}{dx'} \\
 &= -\frac{i\hbar}{\pi^{1/2}d} \int_{-\infty}^{+\infty} dx' \exp\left(-\frac{x'^2}{d^2}\right) \left(ik - \frac{x'}{d^2}\right) \\
 &= -\frac{i\hbar}{\pi^{1/2}d} ikd\pi^{1/2} \\
 &= \hbar k,
 \end{aligned} \tag{3.101}$$

$$\begin{aligned}
 \langle p^2 \rangle &= (-i\hbar)^2 \int_{-\infty}^{+\infty} dx' \psi_{\alpha}^*(x') \frac{d^2\psi_{\alpha}}{dx'^2} \\
 &= (-i\hbar)^2 \frac{1}{\pi^{1/2}d} \int_{-\infty}^{+\infty} dx' \exp\left(-\frac{x'^2}{d^2}\right) \left(\left(\left(ik - \frac{x'}{d^2} \right)^2 - \frac{1}{d^2} \right) \right) \\
 &= (-i\hbar)^2 \frac{1}{\pi^{1/2}d} \left(-\frac{1}{2} \right) d\sqrt{\pi} \frac{2d^4k^2 + d^2}{d^4} \\
 &= (\hbar k)^2 \left(1 + \frac{1}{2(dk)^2} \right),
 \end{aligned} \tag{3.102}$$

a) thus

$$\langle (\Delta x)^2 \rangle \langle (\Delta p)^2 \rangle = \frac{d^2}{2} \left((\hbar k)^2 \left(1 + \frac{1}{2(dk)^2} \right) - (\hbar k)^2 \right) = \frac{\hbar^2}{4}. \tag{3.103}$$

b) Using Eq. (3.60) one has

$$\begin{aligned}
 \langle p' | \alpha \rangle &= \frac{1}{\sqrt{2\pi\hbar}} \int dx' \exp\left(-\frac{ip'x'}{\hbar}\right) \psi_{\alpha}(x') \\
 &= \frac{1}{\sqrt{2\pi\hbar}} \frac{1}{\pi^{1/4}\sqrt{d}} \int_{-\infty}^{\infty} dx' \exp\left(\left(ik - \frac{ip'}{\hbar} \right) x' - \frac{x'^2}{2d^2} \right) \\
 &= \frac{\sqrt{d}}{\pi^{1/4}\sqrt{\hbar}} \exp\left(-\frac{(\hbar k - p')^2 d^2}{2\hbar^2} \right).
 \end{aligned} \tag{3.104}$$

5. The momentum wavefunction is found using Eq. (3.60)

$$\begin{aligned}
\phi_\alpha(p') &= \frac{1}{\sqrt{2\pi\hbar}} \int_{-\infty}^{\infty} dx' \exp\left(-\frac{ip'x'}{\hbar}\right) \langle x' | \alpha \rangle \\
&= \frac{1}{\sqrt{4\pi a\hbar}} \int_{-a}^a dx' \exp\left(-\frac{ip'x'}{\hbar}\right) \\
&= \sqrt{\frac{a}{\pi\hbar}} \frac{\sin \frac{ap'}{\hbar}}{\frac{ap'}{\hbar}}.
\end{aligned} \tag{3.105}$$

The momentum wavefunction $\phi_\alpha(p')$ is normalizable, however, the integrals for evaluating both $\langle p \rangle$ and $\langle p^2 \rangle$ do not converge.

6. Using Eqs. (3.29) and (3.32) one has

$$\begin{aligned}
p|\alpha\rangle &= \int_{-\infty}^{\infty} dx' |x'\rangle \langle x'| p |\alpha\rangle \\
&= -i\hbar \int_{-\infty}^{\infty} dx' |x'\rangle \frac{d}{dx'} \langle x' | \alpha \rangle,
\end{aligned} \tag{3.106}$$

thus, since $|\alpha\rangle$ is an arbitrary ket vector, the following holds

$$p = -i\hbar \int_{-\infty}^{\infty} dx' |x'\rangle \frac{d}{dx'} \langle x'|. \tag{3.107}$$

7. With the help of Eqs. (3.66), (3.71) and (3.75) one finds that

$$\begin{aligned}
\delta(\mathbf{r}' - \mathbf{r}'') &= \langle \mathbf{r}' | \mathbf{r}'' \rangle \\
&= \int d^3\mathbf{p}' \langle \mathbf{r}' | \mathbf{p}' \rangle \langle \mathbf{p}' | \mathbf{r}'' \rangle \\
&= \frac{1}{(2\pi\hbar)^3} \int d^3\mathbf{p}' \exp\left(\frac{i\mathbf{p}' \cdot (\mathbf{r}' - \mathbf{r}'')}{\hbar}\right).
\end{aligned} \tag{3.108}$$

8. Using the identity (2.182), which is given by

$$e^L A e^{-L} = A + [L, A] + \frac{1}{2!} [L, [L, A]] + \frac{1}{3!} [L, [L, [L, A]]] + \dots \tag{3.109}$$

and the identity (3.76), which is given by

$$[g(x), p] = i\hbar \frac{dg}{dx}, \tag{3.110}$$

one finds that

$$e^{g(x)} p e^{-g(x)} = p + i\hbar \frac{dg}{dx} + \frac{i\hbar}{2!} \left[g(x), \frac{dg}{dx} \right] + \frac{i\hbar}{3!} \left[g(x), \left[g(x), \frac{dg}{dx} \right] \right] + \dots \quad (3.111)$$

Choosing $g(x)$ to be given by

$$g(x) = \frac{Kx^2}{2i\hbar} \quad (3.112)$$

yields

$$UpU^\dagger = p + Kx = O, \quad (3.113)$$

where the unitary operator U is given by

$$U = e^{-\frac{iKx^2}{2\hbar}}.$$

Thus, the vectors $|\psi(p')\rangle$, which are defined as

$$|\psi(p')\rangle = U |p'\rangle, \quad (3.114)$$

where $|p'\rangle$ is an eigenvector of p with eigenvalue p' (i.e. $p|p'\rangle = p'|p'\rangle$), are eigenvectors of O , and the following holds

$$O|\psi(p')\rangle = p'|\psi(p')\rangle. \quad (3.115)$$

With the help of Eq. (3.52), which is given by

$$\langle x' | p' \rangle = \frac{1}{\sqrt{2\pi\hbar}} e^{\frac{ip'x'}{\hbar}}, \quad (3.116)$$

one finds that the wavefunction $\psi(x'; p') = \langle x' | \psi(p') \rangle$ of the state $|\psi(p')\rangle$ is given by

$$\begin{aligned} \psi(x'; p') &= e^{-\frac{iKx'^2}{2\hbar}} \langle x' | p' \rangle \\ &= \frac{1}{\sqrt{2\pi\hbar}} e^{\frac{i}{\hbar} \left(p'x' - \frac{Kx'^2}{2} \right)}. \end{aligned} \quad (3.117)$$

9. With the help of Eq. (3.32) one finds that

$$p_\alpha = \int_{-\infty}^{\infty} dx' \int_{-\infty}^{\infty} dx'' |x'\rangle \langle x' | p_\alpha | x'' \rangle \langle x''|. \quad (3.118)$$

The requirement $[x, p_\alpha] = 0$ implies that

$$\int_{-\infty}^{\infty} dx' \int_{-\infty}^{\infty} dx'' |x'\rangle \langle x'| p_{\alpha} |x''\rangle (x' - x'') \langle x''| = 0, \quad (3.119)$$

hence $\langle x'| p_{\alpha} |x''\rangle = 0$ unless $x' = x''$. Thus by using the notation

$$\langle x'| p_{\alpha} |x''\rangle = \phi_{\alpha}(x') \delta(x' - x''), \quad (3.120)$$

the operator p_{α} can be expressed as

$$p_{\alpha} = \int_{-\infty}^{\infty} dx' |x'\rangle \phi_{\alpha}(x') \langle x'|. \quad (3.121)$$

The requirement that p_{α} is Hermitian implies that $\phi_{\alpha}(x')$ is real.

a) With the help of Eq. (3.83), which is given by

$$p = -i\hbar \int_{-\infty}^{\infty} dx' |x'\rangle \frac{d}{dx'} \langle x'|, \quad (3.122)$$

one finds that

$$p - p_{\alpha} = \int_{-\infty}^{\infty} dx' |x'\rangle \left(-i\hbar \frac{d}{dx'} - \phi_{\alpha}(x') \right) \langle x'|, \quad (3.123)$$

hence in terms of the wavefunction $\psi_{\alpha}(x') = \langle x' | \alpha \rangle$ of $|\alpha\rangle$ one has

$$\begin{aligned} (p - p_{\alpha}) |\alpha\rangle &= \int_{-\infty}^{\infty} dx' |x'\rangle \left(-i\hbar \frac{d}{dx'} - \phi_{\alpha}(x') \right) \psi_{\alpha}(x') \\ &= \int_{-\infty}^{\infty} dx' |x'\rangle \psi_{\alpha}(x') \left(-i\hbar \frac{d \log \psi_{\alpha}}{dx'} - \phi_{\alpha}(x') \right). \end{aligned} \quad (3.124)$$

Similarly

$$\langle \alpha | (p - p_{\alpha}) = \int_{-\infty}^{\infty} dx' \psi_{\alpha}^*(x') \left(i\hbar \frac{d \log \psi_{\alpha}^*}{dx'} - \phi_{\alpha}^*(x') \right) \langle x'|, \quad (3.125)$$

and thus

$$\begin{aligned} &\langle \alpha | (p - p_{\alpha})^2 | \alpha \rangle \\ &= \int_{-\infty}^{\infty} dx' \rho(x') \left| i\hbar \frac{d \log \psi_{\alpha}}{dx'} + \phi_{\alpha}(x') \right|^2. \end{aligned} \quad (3.126)$$

where

$$\rho(x') = |\psi_\alpha(x')|^2 . \quad (3.127)$$

The minimum value is obtained when (recall that $\phi_\alpha(x')$ is required to be real)

$$\begin{aligned} \phi_\alpha(x') &= \frac{\hbar}{2i} \left(\frac{d \log \psi_\alpha}{dx'} - \frac{d \log \psi_\alpha^*}{dx'} \right) \\ &= \frac{\hbar}{2i} \frac{d \log \frac{\psi_\alpha}{\psi_\alpha^*}}{dx'} , \end{aligned} \quad (3.128)$$

and thus

$$\langle x' | p_\alpha | x'' \rangle = \frac{\hbar}{2i} \frac{d \log \frac{\psi_\alpha}{\psi_\alpha^*}}{dx'} \delta(x' - x'') . \quad (3.129)$$

Note: Comparing this result with the expression for the current density J associated with the state $|\alpha\rangle$ [see Eq. (4.274)] yields the following relation

$$\begin{aligned} J &= \frac{\hbar}{m} \text{Im} \left(\psi_\alpha^* \frac{d\psi_\alpha}{dx'} \right) \\ &= \frac{\rho(x')}{m} \frac{\hbar}{2i} \left(\frac{d \log \psi_\alpha}{dx'} - \frac{d \log \psi_\alpha^*}{dx'} \right) \\ &= \frac{\rho(x')}{m} \phi_\alpha(x') . \end{aligned} \quad (3.130)$$

b) As can be seen from Eqs. (3.123) and (3.128) the following holds

$$\mathcal{P} = i\hbar \int_{-\infty}^{\infty} dx' |x'\rangle \left(-\frac{d}{dx'} + \frac{1}{2} \frac{d \log \frac{\psi_\alpha}{\psi_\alpha^*}}{dx'} \right) \langle x'| , \quad (3.131)$$

hence

$$\begin{aligned} \langle \alpha | \mathcal{P} | \alpha \rangle &= i\hbar \int_{-\infty}^{\infty} dx' \left[-\psi_\alpha^* \frac{d\psi_\alpha}{dx'} + \frac{1}{2} \left(\psi_\alpha^* \frac{d\psi_\alpha}{dx'} - \frac{d\psi_\alpha^*}{dx'} \psi_\alpha \right) \right] \\ &= -\frac{i\hbar}{2} \int_{-\infty}^{\infty} dx' \left(\psi_\alpha^* \frac{d\psi_\alpha}{dx'} + \frac{d\psi_\alpha^*}{dx'} \psi_\alpha \right) \\ &= -\frac{i\hbar}{2} \int_{-\infty}^{\infty} dx' \frac{d\rho(x')}{dx'} \\ &= 0 , \end{aligned} \quad (3.132)$$

thus [see Eqs. (3.126) and (3.128)]

$$\begin{aligned}
\langle (\Delta \mathcal{P})^2 \rangle &= \langle \alpha | \mathcal{P}^2 | \alpha \rangle \\
&= \left(\frac{\hbar}{2} \right)^2 \int_{-\infty}^{\infty} dx' \rho(x') \left| \frac{d \log \psi_{\alpha}}{dx'} + \frac{d \log \psi_{\alpha}^*}{dx'} \right|^2 \\
&= \left(\frac{\hbar}{2} \right)^2 \int_{-\infty}^{\infty} dx' \rho(x') \left(\frac{d \log \rho(x')}{dx'} \right)^2 .
\end{aligned} \tag{3.133}$$

Note that the result $\langle \alpha | \mathcal{P} | \alpha \rangle = 0$ implies that p_{α} and p have the same expectation value, i.e. $\langle \alpha | p_{\alpha} | \alpha \rangle = \langle \alpha | p | \alpha \rangle$. On the other hand, contrary to p , the operator p_{α} commutes with the position operator x .

c) Using the relation $\langle \alpha | p_{\alpha} | \alpha \rangle = \langle \alpha | p | \alpha \rangle$ one finds that

$$\begin{aligned}
\langle (\Delta p)^2 \rangle - \langle (\Delta p_{\alpha})^2 \rangle &= \langle \alpha | p^2 | \alpha \rangle - \langle \alpha | p_{\alpha}^2 | \alpha \rangle \\
&= \langle \alpha | (p - p_{\alpha})^2 | \alpha \rangle + \langle \alpha | (pp_{\alpha} + p_{\alpha}p - 2p_{\alpha}^2) | \alpha \rangle \\
&= \langle \alpha | \mathcal{P}^2 | \alpha \rangle + \langle \alpha | (pp_{\alpha} + p_{\alpha}p - 2p_{\alpha}^2) | \alpha \rangle .
\end{aligned} \tag{3.134}$$

As can be seen from Eq. (3.128), the following holds

$$p_{\alpha} = \hbar \int_{-\infty}^{\infty} dx' |x'\rangle \operatorname{Im} \left(\frac{d \log \psi_{\alpha}}{dx'} \right) \langle x'| , \tag{3.135}$$

thus

$$\begin{aligned}
&\langle \alpha | (pp_{\alpha} + p_{\alpha}p - 2p_{\alpha}^2) | \alpha \rangle \\
&= \hbar^2 \int_{-\infty}^{\infty} dx' \rho \left(\frac{\langle \alpha | p | x' \rangle}{\psi_{\alpha}^*} + \frac{\langle x' | p | \alpha \rangle}{\psi_{\alpha}} - 2 \operatorname{Im} \left(\frac{d \log \psi_{\alpha}}{dx'} \right) \right) \operatorname{Im} \left(\frac{d \log \psi_{\alpha}}{dx'} \right) \\
&= 0 ,
\end{aligned} \tag{3.136}$$

and therefore

$$\begin{aligned}
\langle (\Delta p)^2 \rangle &= \langle \alpha | \mathcal{P}^2 | \alpha \rangle + \langle (\Delta p_{\alpha})^2 \rangle \\
&\geq \langle \alpha | \mathcal{P}^2 | \alpha \rangle \\
&= \left(\frac{\hbar}{2} \right)^2 \int_{-\infty}^{\infty} dx' \rho(x') \left(\frac{d \log \rho(x')}{dx'} \right)^2 .
\end{aligned} \tag{3.137}$$

For general real functions $f(x'), g(x') : \mathcal{R} \rightarrow \mathcal{R}$ the Schwartz inequality (2.172) implies that

$$\left| \int_{-\infty}^{\infty} dx' f(x') g(x') \right|^2 \leq \int_{-\infty}^{\infty} dx' (f(x'))^2 \int_{-\infty}^{\infty} dx' (g(x'))^2 . \quad (3.138)$$

Implementing this inequality for the functions

$$f(x') = \sqrt{\rho(x')} (x' - \langle x \rangle) , \quad (3.139)$$

$$g(x') = \sqrt{\rho(x')} \frac{d \log \rho(x')}{dx'} , \quad (3.140)$$

where

$$\langle x \rangle = \int_{-\infty}^{\infty} dx' \rho(x') x'$$

is the expectation value of x , yields

$$\int_{-\infty}^{\infty} dx' \rho(x') \left(\frac{d \log \rho(x')}{dx'} \right)^2 \geq \frac{\left| \int_{-\infty}^{\infty} dx' \rho(x') (x' - \langle x \rangle) \frac{d \log \rho(x')}{dx'} \right|^2}{\langle (\Delta x)^2 \rangle} , \quad (3.141)$$

where

$$\langle (\Delta x)^2 \rangle = \int_{-\infty}^{\infty} dx' \rho(x') (x' - \langle x \rangle)^2 \quad (3.142)$$

is the variance of x . By integrating by parts one finds that

$$\begin{aligned} \int_{-\infty}^{\infty} dx' \rho(x') (x' - \langle x \rangle) \frac{d \log \rho(x')}{dx'} &= \int_{-\infty}^{\infty} dx' (x' - \langle x \rangle) \frac{d \rho(x')}{dx'} \\ &= - \int_{-\infty}^{\infty} dx' \rho(x') \\ &= -1 . \end{aligned} \quad (3.143)$$

Combining these results [see Eqs. (3.137) and (3.141)] lead to

$$\langle (\Delta x)^2 \rangle \langle (\Delta p)^2 \rangle \geq \left(\frac{\hbar}{2} \right)^2 . \quad (3.144)$$

10. The wavefunction $\phi(x')$ of $\exp(i\hbar^{-1}axp) |\alpha\rangle$ is given by

$$\phi(x') = \langle x' | \exp(i\hbar^{-1}axp) |\alpha\rangle = \sum_{n=0}^{\infty} \langle x' | \frac{(i\hbar^{-1}axp)^n}{n!} |\alpha\rangle , \quad (3.145)$$

hence [see Eqs. (3.21) and (3.29)]

$$\phi(x') = \sum_{n=0}^{\infty} \frac{S^n}{n!} \psi_{\alpha}(x'), \quad (3.146)$$

where

$$S = ax' \frac{d}{dx'}. \quad (3.147)$$

The following holds

$$Sx'^m = amx'^m, \quad (3.148)$$

and thus

$$\sum_{n=0}^{\infty} \frac{S^n}{n!} x'^m = \sum_{n=0}^{\infty} \frac{(am)^n}{n!} x'^m = e^{am} x'^m = (e^a x')^m, \quad (3.149)$$

and therefore

$$\phi(x') = \psi_{\alpha}(e^a x'). \quad (3.150)$$

Alternatively, the following holds [see Eqs. (3.21) and (3.29)]

$$\begin{aligned} \frac{d\phi}{da} &= \frac{d}{da} \langle x' | \exp(i\hbar^{-1}axp) | \alpha \rangle \\ &= i\hbar^{-1} \langle x' | xp \exp(i\hbar^{-1}axp) | \alpha \rangle \\ &= i\hbar^{-1} x' \langle x' | p \exp(i\hbar^{-1}axp) | \alpha \rangle \\ &= x' \frac{d\phi}{dx'}, \end{aligned} \quad (3.151)$$

hence $dx'/da = x'$. The initial condition $\phi(x') = \psi_{\alpha}(x')$ for the case $a = 0$ leads to Eq. (3.150).

11. Using the relation $pp^{-1} = 1$ one finds that $\psi_{\alpha}(x') = \langle x' | \alpha \rangle = \langle x' | pp^{-1} | \alpha \rangle$, thus the wavefunction of $p^{-1} | \alpha \rangle$ is given by $i\hbar^{-1} \int_{-\infty}^x dx' \psi_{\alpha}(x')$ [see Eq. (3.29)].

4. Quantum Dynamics

The time evolution of a state vector $|\alpha\rangle$ is postulated to be given by the Schrödinger equation

$$i\hbar \frac{d|\alpha\rangle}{dt} = \mathcal{H}|\alpha\rangle, \quad (4.1)$$

where the Hermitian operator $\mathcal{H} = \mathcal{H}^\dagger$ is the Hamiltonian of the system. The Hamiltonian operator is the observable corresponding to the classical Hamiltonian function that we have studied in chapter 1. The time evolution produced by Eq. (4.1) is unitary, as is shown below:

Claim. The norm $\langle\alpha|\alpha\rangle$ is time independent.

Proof. Since $\mathcal{H} = \mathcal{H}^\dagger$, the dual of the Schrödinger equation (4.1) is given by

$$-i\hbar \frac{d\langle\alpha|}{dt} = \langle\alpha|\mathcal{H}. \quad (4.2)$$

Using this one has

$$\frac{d\langle\alpha|\alpha\rangle}{dt} = \left(\frac{d\langle\alpha|}{dt}\right)|\alpha\rangle + \langle\alpha|\frac{d|\alpha\rangle}{dt} = \frac{1}{i\hbar}(-\langle\alpha|\mathcal{H}|\alpha\rangle + \langle\alpha|\mathcal{H}|\alpha\rangle) = 0. \quad (4.3)$$

4.1 Time Evolution Operator

The time evolution operator $u(t, t_0)$ relates the state vector at time $|\alpha(t_0)\rangle$ with its value $|\alpha(t)\rangle$ at time t :

$$|\alpha(t)\rangle = u(t, t_0)|\alpha(t_0)\rangle. \quad (4.4)$$

Claim. The time evolution operator satisfies the Schrödinger equation (4.1).

Proof. Expressing the Schrödinger equation (4.1) in terms of Eq. (4.4)

$$i\hbar \frac{d}{dt}u(t, t_0)|\alpha(t_0)\rangle = \mathcal{H}u(t, t_0)|\alpha(t_0)\rangle, \quad (4.5)$$

and noting that $|\alpha(t_0)\rangle$ is t independent yield

$$i\hbar \left(\frac{d}{dt} u(t, t_0) \right) |\alpha(t_0)\rangle = \mathcal{H} u(t, t_0) |\alpha(t_0)\rangle . \quad (4.6)$$

Since this holds for any $|\alpha(t_0)\rangle$ one concludes that

$$i\hbar \frac{du(t, t_0)}{dt} = \mathcal{H} u(t, t_0) . \quad (4.7)$$

This result leads to the following conclusion:

Claim. The time evolution operator is unitary.

Proof. Using Eq. (4.7) one finds that

$$\begin{aligned} \frac{d(u^\dagger u)}{dt} &= u^\dagger \frac{du}{dt} + \frac{du^\dagger}{dt} u \\ &= \frac{1}{i\hbar} (u^\dagger \mathcal{H} u - u^\dagger \mathcal{H} u) \\ &= 0 . \end{aligned} \quad (4.8)$$

Furthermore, for $t = t_0$ clearly $u(t_0, t_0) = u^\dagger(t_0, t_0) = 1$. Thus, one concludes that $u^\dagger u = 1$ for any time, namely u is unitary.

4.2 Time Independent Hamiltonian

A special case of interest is when the Hamiltonian is time independent. In this case the solution of Eq. (4.7) is given by

$$u(t, t_0) = \exp \left(-\frac{i\mathcal{H}(t-t_0)}{\hbar} \right) . \quad (4.9)$$

The operator $u(t, t_0)$ takes a relatively simple form in the basis of eigenvectors of the Hamiltonian \mathcal{H} . Denoting these eigenvectors as $|a_{n,i}\rangle$, where the index i is added to account for possible degeneracy, and denoting the corresponding eigenenergies as E_n one has

$$\mathcal{H} |a_{n,i}\rangle = E_n |a_{n,i}\rangle , \quad (4.10)$$

where

$$\langle a_{n',i'} | a_{n,i} \rangle = \delta_{nn'} \delta_{ii'} . \quad (4.11)$$

By using the closure relation, which is given by

$$1 = \sum_n \sum_{i=1}^{g_n} |a_{n,i}\rangle \langle a_{n,i}| , \quad (4.12)$$

and Eq. (4.9) one finds that

$$\begin{aligned}
 u(t, t_0) &= \exp\left(-\frac{i\mathcal{H}(t-t_0)}{\hbar}\right) 1 \\
 &= \sum_n \sum_{i=1}^{g_n} \exp\left(-\frac{i\mathcal{H}(t-t_0)}{\hbar}\right) |a_{n,i}\rangle \langle a_{n,i}| \\
 &= \sum_n \sum_{i=1}^{g_n} \exp\left(-\frac{iE_n(t-t_0)}{\hbar}\right) |a_{n,i}\rangle \langle a_{n,i}| .
 \end{aligned} \tag{4.13}$$

Using this results the state vector $|\alpha(t)\rangle$ can be written as

$$\begin{aligned}
 |\alpha(t)\rangle &= u(t, t_0) |\alpha(t_0)\rangle \\
 &= \sum_n \sum_{i=1}^{g_n} \exp\left(-\frac{iE_n(t-t_0)}{\hbar}\right) \langle a_{n,i} | \alpha(t_0)\rangle |a_{n,i}\rangle .
 \end{aligned} \tag{4.14}$$

Note that if the system is initially in an eigenvector of the Hamiltonian with eigenenergy E_n , then according to Eq. (4.14)

$$|\alpha(t)\rangle = \exp\left(-\frac{iE_n(t-t_0)}{\hbar}\right) |\alpha(t_0)\rangle . \tag{4.15}$$

However, the phase factor multiplying $|\alpha(t_0)\rangle$ has no effect on any measurable physical quantity of the system, that is, the system's properties are time independent. This is why the eigenvectors of the Hamiltonian are called stationary states.

4.3 Example - Spin 1/2

In classical mechanics, the potential energy U of a magnetic moment $\boldsymbol{\mu}$ in a magnetic field \mathbf{B} is given by

$$U = -\boldsymbol{\mu} \cdot \mathbf{B} . \tag{4.16}$$

The magnetic moment of a spin 1/2 is given by [see Eq. (2.91)]

$$\boldsymbol{\mu}_{\text{spin}} = \frac{2\mu_B}{\hbar} \mathbf{S} , \tag{4.17}$$

where \mathbf{S} is the spin angular momentum vector and where

$$\mu_B = \frac{e\hbar}{2m_e c} \tag{4.18}$$

is the Bohr's magneton (note that the electron charge is taken to be negative $e < 0$). Based on these relations we hypothesize that the Hamiltonian of a spin 1/2 in a magnetic field \mathbf{B} is given by

$$\mathcal{H} = -\frac{e}{m_e c} \mathbf{S} \cdot \mathbf{B} . \quad (4.19)$$

Assume the case where

$$\mathbf{B} = B \hat{\mathbf{z}} , \quad (4.20)$$

where B is a constant. For this case the Hamiltonian is given by

$$\mathcal{H} = \omega S_z , \quad (4.21)$$

where

$$\omega = \frac{|e| B}{m_e c} \quad (4.22)$$

is the so-called Larmor frequency. In terms of the eigenvectors of the operator S_z

$$S_z |\pm\rangle = \pm \frac{\hbar}{2} |\pm\rangle , \quad (4.23)$$

where the compact notation $|\pm\rangle$ stands for the states $|\pm; \hat{\mathbf{z}}\rangle$, one has

$$\mathcal{H} |\pm\rangle = \pm \frac{\hbar \omega}{2} |\pm\rangle , \quad (4.24)$$

namely the states $|\pm\rangle$ are eigenstates of the Hamiltonian. Equation (4.13) for the present case reads

$$u(t, 0) = e^{-\frac{i\omega t}{2}} |+\rangle \langle +| + e^{\frac{i\omega t}{2}} |-\rangle \langle -| . \quad (4.25)$$

Exercise 4.3.1. Consider spin 1/2 in magnetic field given by $\mathbf{B} = B \hat{\mathbf{z}}$, where B is a constant. Given that $|\alpha(0)\rangle = |+; \hat{\mathbf{x}}\rangle$ at time $t = 0$ calculate (a) the probability $p_{\pm}(t)$ to measure $S_x = \pm \hbar/2$ at time t ; (b) the expectation value $\langle S_x \rangle(t)$ at time t .

Solution 4.3.1. Recall that [see Eq. (2.103)]

$$|\pm; \hat{\mathbf{x}}\rangle = \frac{1}{\sqrt{2}} (|+\rangle \pm |-\rangle) \quad (4.26)$$

(a) Using Eq. (4.25) one finds

$$\begin{aligned} p_{\pm}(t) &= |\langle \pm; \hat{\mathbf{x}} | u(t, 0) | \alpha(0) \rangle|^2 \\ &= \left| \frac{1}{2} (\langle + | \pm \langle - |) \left(e^{-\frac{i\omega t}{2}} |+\rangle \langle +| + e^{\frac{i\omega t}{2}} |-\rangle \langle -| \right) (|+\rangle + |-\rangle) \right|^2 \\ &= \left| \frac{1}{2} \left(e^{-\frac{i\omega t}{2}} \pm e^{\frac{i\omega t}{2}} \right) \right|^2 , \end{aligned} \quad (4.27)$$

thus

$$p_+(t) = \cos^2\left(\frac{\omega t}{2}\right), \quad (4.28)$$

$$p_-(t) = \sin^2\left(\frac{\omega t}{2}\right). \quad (4.29)$$

(b) Using the results for p_+ and p_- one has

$$\begin{aligned} \langle S_x \rangle &= \frac{\hbar}{2} (p_+ - p_-) \\ &= \frac{\hbar}{2} \left(\cos^2\left(\frac{\omega t}{2}\right) - \sin^2\left(\frac{\omega t}{2}\right) \right) \\ &= \frac{\hbar}{2} \cos(\omega t). \end{aligned} \quad (4.30)$$

4.4 Connection to Classical Dynamics

In chapter 1 we have found that in classical physics, the dynamics of a variable $A^{(c)}$ is governed by Eq. (1.38), which is given by

$$\frac{dA^{(c)}}{dt} = \{A^{(c)}, \mathcal{H}^{(c)}\} + \frac{\partial A^{(c)}}{\partial t}. \quad (4.31)$$

We seek a quantum analogy to this equation. To that end, we derive an equation of motion for the expectation value $\langle A \rangle$ of the observable A that corresponds to the classical variable $A^{(c)}$. In general, the expectation value can be expressed as

$$\langle A \rangle = \langle \alpha(t) | A | \alpha(t) \rangle = \langle \alpha(t_0) | u^\dagger(t, t_0) A u(t, t_0) | \alpha(t_0) \rangle = \langle \alpha(t_0) | A^{(H)} | \alpha(t_0) \rangle, \quad (4.32)$$

where u is the time evolution operator and

$$A^{(H)} = u^\dagger(t, t_0) A u(t, t_0). \quad (4.33)$$

The operator $A^{(H)}$ is called the Heisenberg representation of A . We first derive an equation of motion for the operator $A^{(H)}$. By using Eq. (4.7) one finds that the following holds

$$\frac{du}{dt} = \frac{1}{i\hbar} \mathcal{H}u, \quad (4.34)$$

$$\frac{du^\dagger}{dt} = -\frac{1}{i\hbar} u^\dagger \mathcal{H}, \quad (4.35)$$

therefore

$$\begin{aligned}
\frac{dA^{(\text{H})}}{dt} &= \frac{du^\dagger}{dt} Au + u^\dagger A \frac{du}{dt} + u^\dagger \frac{\partial A}{\partial t} u \\
&= \frac{1}{i\hbar} (-u^\dagger \mathcal{H} Au + u^\dagger A \mathcal{H} u) + u^\dagger \frac{\partial A}{\partial t} u \\
&= \frac{1}{i\hbar} (-u^\dagger \mathcal{H} u u^\dagger Au + u^\dagger A u u^\dagger \mathcal{H} u) + u^\dagger \frac{\partial A}{\partial t} u \\
&= \frac{1}{i\hbar} \left(-\mathcal{H}^{(\text{H})} A^{(\text{H})} + A^{(\text{H})} \mathcal{H}^{(\text{H})} \right) + \left(\frac{\partial A}{\partial t} \right)^{(\text{H})}.
\end{aligned} \tag{4.36}$$

Thus, we have found that

$$\frac{dA^{(\text{H})}}{dt} = \frac{1}{i\hbar} \left[A^{(\text{H})}, \mathcal{H}^{(\text{H})} \right] + \left(\frac{\partial A}{\partial t} \right)^{(\text{H})}. \tag{4.37}$$

Furthermore, the desired equation of motion for $\langle A \rangle$ is found using Eqs. (4.32) and (4.37)

$$\frac{d\langle A \rangle}{dt} = \frac{1}{i\hbar} \langle [A, \mathcal{H}] \rangle + \left\langle \frac{\partial A}{\partial t} \right\rangle. \tag{4.38}$$

We see that the Poisson's brackets in the classical equation of motion (4.31) for the classical variable $A^{(\text{c})}$ are replaced by a commutation relation in the quantum counterpart equation of motion (4.38) for the expectation value $\langle A \rangle$

$$\{, \} \rightarrow \frac{1}{i\hbar} [,] . \tag{4.39}$$

Note that for the case where the Hamiltonian is time independent, namely for the case where the time evolution operator is given by Eq. (4.9), u commutes with \mathcal{H} , namely $[u, \mathcal{H}] = 0$, and consequently

$$\mathcal{H}^{(\text{H})} = u^\dagger \mathcal{H} u = \mathcal{H} . \tag{4.40}$$

4.5 Symmetric Ordering

What is in general the correspondence between a classical variable and its quantum operator counterpart? Consider for example the system of a point particle moving in one dimension. Let $x^{(\text{c})}$ be the classical coordinate and let $p^{(\text{c})}$ be the canonically conjugate momentum. As we have done in chapter 3, the quantum observables corresponding to $x^{(\text{c})}$ and $p^{(\text{c})}$ are the Hermitian operators x and p . The commutation relation $[x, p]$ is derived from the corresponding Poisson's brackets $\{x^{(\text{c})}, p^{(\text{c})}\}$ according to the rule

$$\{, \} \rightarrow \frac{1}{i\hbar} [,] , \tag{4.41}$$

namely

$$\left\{ x^{(c)}, p^{(c)} \right\} = 1 \rightarrow [x, p] = i\hbar . \quad (4.42)$$

However, what is the quantum operator corresponding to a general function $A(x^{(c)}, p^{(c)})$ of $x^{(c)}$ and $p^{(c)}$? This question raises the issue of ordering. As an example, let $A(x^{(c)}, p^{(c)}) = x^{(c)}p^{(c)}$. Classical variables obviously commute, therefore $x^{(c)}p^{(c)} = p^{(c)}x^{(c)}$. However, this is not true for quantum operators $xp \neq px$. Moreover, it is clear that both operators xp and px cannot be considered as observables since they are not Hermitian

$$(xp)^\dagger = px \neq xp , \quad (4.43)$$

$$(px)^\dagger = xp \neq px . \quad (4.44)$$

A better candidate to serve as the quantum operator corresponding to the classical variables $x^{(c)}p^{(c)}$ is the operator $(xp + px)/2$, which is obtained from $x^{(c)}p^{(c)}$ by a procedure called symmetric ordering. A general transformation that produces a symmetric ordered observable $A(x, p)$ that corresponds to a given general function $A(x^{(c)}, p^{(c)})$ of the classical variable $x^{(c)}$ and its canonical conjugate $p^{(c)}$ is given below

$$A(x, p) = \int_{-\infty}^{\infty} \int_{-\infty}^{\infty} A(x^{(c)}, p^{(c)}) \Upsilon dx^{(c)} dp^{(c)} , \quad (4.45)$$

where

$$\Upsilon = \frac{1}{(2\pi\hbar)^2} \int_{-\infty}^{\infty} \int_{-\infty}^{\infty} e^{\frac{i}{\hbar}(\xi(x^{(c)}-x)+\eta(p^{(c)}-p))} d\xi d\eta . \quad (4.46)$$

This transformation is called the Weyl transformation. The identity

$$\int_{-\infty}^{\infty} dk e^{ik(x'-x'')} = 2\pi\delta(x' - x'') , \quad (4.47)$$

implies that

$$\frac{1}{2\pi\hbar} \int e^{\frac{i}{\hbar}\xi(x^{(c)}-x)} d\xi = \delta(x^{(c)} - x) , \quad (4.48)$$

$$\frac{1}{2\pi\hbar} \int e^{\frac{i}{\hbar}\eta(p^{(c)}-p)} d\eta = \delta(p^{(c)} - p) . \quad (4.49)$$

At first glance these relations may lead to the (wrong) conclusion that the term Υ equals to $\delta(x^{(c)} - x) \delta(p^{(c)} - p)$, however, this is incorrect since x and p are non-commuting operators.

4.6 Problems

1. Consider a system having Hamiltonian \mathcal{H} and time evolution operator $u(t, t_0)$. The operator Z is defined by

$$Z = \frac{du}{dt} u^\dagger . \quad (4.50)$$

Express Z in terms of \mathcal{H} .

2. The observables $A = A^\dagger$ and $B = B^\dagger$ are both constants of the motion of a given system having time independent operator \mathcal{H} . Assume that both A and B do not explicitly depend on time. Show that the Hermitian operators O_+ and O_- , which are given by

$$O_+ = \frac{AB + BA}{2} , \quad (4.51)$$

$$O_- = \frac{AB - BA}{2i} , \quad (4.52)$$

are also constants of the motion of the same system.

3. Consider spin 1/2 in magnetic field given by $\mathbf{B} = B\hat{\mathbf{z}}$, where B is a constant. At time $t = 0$ the system is in the state $|+; \hat{\mathbf{x}}\rangle$. Calculate $\langle S_x \rangle$, $\langle S_y \rangle$ and $\langle S_z \rangle$ as a function of time t .
4. The dynamics of a given system is governed by the Hamiltonian \mathcal{H} , which is assumed to be time independent. The state of the system $|\psi_0\rangle$ and the variance of the Hamiltonian operator $\langle (\Delta\mathcal{H})^2 \rangle$ at time $t = 0$ are given. The observable $P = |\psi_0\rangle \langle \psi_0|$ is measured at time t . Calculate the expectation value $\langle P \rangle$ to second order in t and express the result in terms of $\langle (\Delta\mathcal{H})^2 \rangle$.
5. Consider a point particle having mass m moving in one dimension under the influence of the potential $V(x)$. Let $|\psi_n\rangle$ be a normalized eigenvector of the Hamiltonian of the system with eigenvalue E_n . Show that the corresponding wavefunction $\psi_n(x')$ in the coordinate representation satisfies the following equation

$$-\frac{\hbar^2}{2m} \frac{d^2\psi_n(x')}{dx'^2} + V(x')\psi_n(x') = E_n\psi_n(x') . \quad (4.53)$$

6. Consider the Hamiltonian operator

$$\mathcal{H} = \frac{\mathbf{p}^2}{2m} + V(\mathbf{r}) , \quad (4.54)$$

where $\mathbf{r} = (x, y, z)$ is the vector of position operators, $\mathbf{p} = (p_x, p_y, p_z)$ is the vector of canonical conjugate operators, and the mass m is a constant. Let $|\psi_n\rangle$ be a *normalizable* eigenvector of the Hamiltonian \mathcal{H} with eigenvalue E_n . Show that

$$\langle \psi_n | \mathbf{p} | \psi_n \rangle = 0 . \quad (4.55)$$

7. Show that in the p representation the Schrödinger equation

$$i\hbar \frac{d|\alpha\rangle}{dt} = \mathcal{H}|\alpha\rangle, \quad (4.56)$$

where \mathcal{H} is the Hamiltonian

$$\mathcal{H} = \frac{\mathbf{p}^2}{2m} + V(\mathbf{r}), \quad (4.57)$$

can be transformed into the integro-differential equation

$$i\hbar \frac{d}{dt} \phi_\alpha = \frac{\mathbf{p}^2}{2m} \phi_\alpha + \int d\mathbf{p}' U(\mathbf{p} - \mathbf{p}') \phi_\alpha, \quad (4.58)$$

where $\phi_\alpha = \phi_\alpha(\mathbf{p}', t) = \langle \mathbf{p}' | \alpha \rangle$ is the momentum wave function and where

$$U(\mathbf{p}) = (2\pi\hbar)^{-3} \int d\mathbf{r} V(\mathbf{r}) \exp\left(-\frac{i}{\hbar} \mathbf{p} \cdot \mathbf{r}\right). \quad (4.59)$$

8. Consider a particle of mass m in a scalar potential energy $V(\mathbf{r})$. Prove Ehrenfest's theorem

$$m \frac{d^2}{dt^2} \langle \mathbf{r} \rangle = - \langle \nabla V(\mathbf{r}) \rangle. \quad (4.60)$$

9. Show that if the potential energy $V(\mathbf{r})$ can be written as a sum of functions of a single coordinate, $V(\mathbf{r}) = V_1(x_1) + V_2(x_2) + V_3(x_3)$, then the time-independent Schrödinger equation can be decomposed into a set of one-dimensional equations of the form

$$\frac{d^2 \psi_i(x_i)}{dx_i^2} + \frac{2m}{\hbar^2} [E_i - V_i(x_i)] \psi_i(x_i) = 0, \quad (4.61)$$

where $i \in \{1, 2, 3\}$, with $\psi(\mathbf{r}) = \psi_1(x_1) \psi_2(x_2) \psi_3(x_3)$ and $E = E_1 + E_2 + E_3$.

10. Show that, in one-dimensional problems, the energy spectrum of the bound states is always non-degenerate.
11. Let $\psi_n(x)$ ($n = 1, 2, 3, \dots$) be the eigen-wave-functions of a one-dimensional Schrödinger equation with eigen-energies E_n placed in order of increasing magnitude ($E_1 < E_2 < \dots$). Show that between any two consecutive zeros of $\psi_n(x)$, $\psi_{n+1}(x)$ has at least one zero.
12. What conclusions can be drawn about the parity of the eigen-functions of the one-dimensional Schrödinger equation

$$\frac{d^2 \psi(x)}{dx^2} + \frac{2m}{\hbar^2} (E - V(x)) \psi(x) = 0 \quad (4.62)$$

if the potential energy is an even function of x , namely $V(x) = V(-x)$.

13. Show that the first derivative of the time-independent wavefunction is continuous even at points where $V(x)$ has a finite discontinuity.
14. A particle having mass m is confined by a one-dimensional potential given by

$$V_s(x) = \begin{cases} -W & \text{if } |x| \leq a \\ 0 & \text{if } |x| > a \end{cases}, \quad (4.63)$$

where $a > 0$ and $W > 0$ are real constants. Show that the particle has at least one bound state (i.e., a state having energy $E < 0$).

15. Consider a particle having mass m confined in a potential well given by

$$V(x) = \begin{cases} 0 & \text{if } 0 \leq x \leq a \\ \infty & \text{if } x < 0 \text{ or } x > a \end{cases}. \quad (4.64)$$

The eigenenergies are denoted by E_n and the corresponding eigen states are denoted by $|\varphi_n\rangle$, where $n = 1, 2, \dots$ (as usual, the states are numbered in increasing order with respect to energy). The state of the system at time $t = 0$ is given by

$$|\Psi(0)\rangle = a_1 |\varphi_1\rangle + a_2 |\varphi_2\rangle + a_3 |\varphi_3\rangle. \quad (4.65)$$

- (a) The energy E of the system is measured at time $t = 0$. What is the probability to measure a value smaller than $3\pi^2\hbar^2/(ma^2)$? (b) Calculate the standard deviation $\Delta E = \sqrt{\langle E^2 \rangle - \langle E \rangle^2}$ at time $t = 0$. (c) the same as (b), however for any time $t > 0$. (d) The energy was measured at time t and the value of $2\pi^2\hbar^2/(ma^2)$ was found. The energy is measured again at later time $t_0 > t$. Calculate $\langle E \rangle$ and $\langle \Delta E \rangle$ at time t_0 .
16. Consider a particle having mass m confined in a potential well given by

$$V(x) = \begin{cases} 0 & \text{if } 0 \leq x \leq a \\ \infty & \text{if } x < 0 \text{ or } x > a \end{cases}. \quad (4.66)$$

Initially, the wave function at time $t = 0$ is given by

$$\psi(t=0) = N \sin^3 \frac{\pi x}{a}, \quad (4.67)$$

where N is a normalization constant. Calculate $\psi(t)$ for $t > 0$.

17. Consider the position wave function $\psi(x')$, which is given by

$$\psi(x') = A \left(\frac{x'}{x_0} \right)^2 \exp\left(-\frac{x'}{x_0}\right), \quad (4.68)$$

where both A and x_0 are positive constants. The wave function $\psi(x')$ is an eigen function of a Hamiltonian of a particle having mass m moving in one dimension along the x axis under the influence of a potential energy $V(x')$. The corresponding eigen energy is E . Calculate the potential $V(x')$.

18. Consider a point particle having mass m in a one-dimensional potential given by

$$V(x) = -\alpha\delta(x) , \quad (4.69)$$

where $\delta(x)$ is the delta function. The value of the parameter α suddenly changes from α_1 at times $t < 0$ to the value α_2 at times $t > 0$. Both α_1 and α_2 are positive real numbers. Given that the particle was in the ground state at times $t < 0$, what is the probability p that the particle will remain bounded at $t > 0$?

19. Consider a point particle having mass m in a one-dimensional potential given by

$$V(x) = -\alpha\delta(x) , \quad (4.70)$$

where $\delta(x)$ is the delta function, and where $\alpha > 0$. Let $|\gamma_0\rangle$ be the ground state and let E_0 be the energy of the ground state. The particle is prepared in the state

$$|g(p_0)\rangle = \exp\left(\frac{ip_0x}{\hbar}\right) |\gamma_0\rangle , \quad (4.71)$$

where p_0 is real and where x is the position operator. Calculate the probability $s(p_0)$ that a measurement of energy will yield the result E_0 .

20. Consider a point particle having mass m in a one-dimensional potential $V(x)$ given by

$$V(x) = -\alpha\delta(x) , \quad (4.72)$$

where $\delta(x)$ is the delta function, and where $\alpha > 0$. Calculate the momentum wavefunction $\phi_0(p')$ of the ground state.

21. Consider a point particle having mass m in a one-dimensional potential given by

$$V(x) = -\alpha(\delta(x-a) + \delta(x+a)) , \quad (4.73)$$

where both α and a are positive, and δ denotes the delta function. Find the energies of the bound states.

22. Consider a point particle having mass m in a one-dimensional potential given by

$$V(x) = \begin{cases} -\alpha\delta(x) & |x| < a \\ \infty & |x| \geq a \end{cases} , \quad (4.74)$$

where $\delta(x)$ is the delta function and α is a constant. Let E_0 be the energy of the ground state. Under what conditions $E_0 < 0$?

23. The same as the previous exercise, however for the potential

$$V(x) = \begin{cases} \infty & x < 0 \\ -\alpha\delta(x - x_0) & x \geq 0 \end{cases}, \quad (4.75)$$

where α is real and x_0 is positive.

24. **Thomas-Reiche-Kuhn sum rule** - Let

$$\mathcal{H} = \frac{\mathbf{p}^2}{2m} + V(\mathbf{r}) \quad (4.76)$$

be the Hamiltonian of a particle of mass m moving in a potential $V(\mathbf{r})$. Show that

$$\sum_k (E_k - E_l) |\langle k|x|l\rangle|^2 = \frac{\hbar^2}{2m}, \quad (4.77)$$

where the sum is taken over all energy eigen-states of the particle (where $\mathcal{H}|k\rangle = E_k|k\rangle$), and x is the x component of the position vector operator \mathbf{r} .

25. A particle having mass m is confined in a one-dimensional potential well given by

$$V(x) = \begin{cases} 0 & 0 < x < a \\ \infty & \text{else} \end{cases}.$$

- a) At time $t = 0$ the position was measured and the result was $x = a/2$. The resolution of the position measurement is Δx , where $\Delta x \ll a$. After time τ_1 the energy was measured. Calculate the probability p_n to measure that the energy of the system is E_n , where E_n are the eigenenergies of the particle in the well, and where $n = 1, 2, \dots$.
- b) Assume that the result of the measurement in the previous section was E_2 . At a later time $\tau_2 > \tau_1$ the momentum p of the particle was measured. Calculate the expectation value $\langle p \rangle$.
26. A particle having mass m is in the ground state of an infinite potential well of width a , which is given by

$$V_1(x) = \begin{cases} 0 & 0 < x < a \\ \infty & \text{else} \end{cases}. \quad (4.78)$$

At time $t = 0$ the potential suddenly changes and becomes

$$V_2(x) = \begin{cases} 0 & 0 < x < 2a \\ \infty & \text{else} \end{cases}, \quad (4.79)$$

namely the width suddenly becomes $2a$. (a) Find the probability p to find the particle in the ground state of the new well. (b) Calculate the expectation value of the energy $\langle \mathcal{H} \rangle$ before and after the change in the potential.

27. Calculate the uncertainties in position $\langle (\Delta x)^2 \rangle$ and in momentum $\langle (\Delta p)^2 \rangle$ of the energy eigenstates of a particle having mass m , which is confined in a one-dimensional potential well given by

$$V(x) = \begin{cases} 0 & 0 < x < a \\ \infty & \text{else} \end{cases} . \quad (4.80)$$

28. **The continuity equation** - Consider a point particle having mass m and charge q placed in an electromagnetic field. Show that

$$\frac{d\rho}{dt} + \nabla \mathbf{J} = 0 , \quad (4.81)$$

where

$$\rho = \psi\psi^* \quad (4.82)$$

is the probability distribution function, $\psi(x')$ is the wavefunction,

$$\mathbf{J} = \frac{\hbar}{m} \text{Im}(\psi^* \nabla \psi) - \frac{q\rho}{mc} \mathbf{A} \quad (4.83)$$

is the current density, and \mathbf{A} is the electromagnetic vector potential.

29. A particle having mass m moves in one dimension under the influence of the potential $V(x')$. In the range $|x'| > a$ the potential $V(x')$ vanishes, i.e. $V(x') = 0$. Consider a solution to the time independent Schrödinger equation, whose wavefunction $\psi(x')$ in the range $|x'| > a$ is taken to be given by

$$\psi(x') = \begin{cases} A_1 e^{ikx'} + B_1 e^{-ikx'} & x' < -a \\ A_2 e^{ikx'} + B_2 e^{-ikx'} & x' > a \end{cases} , \quad (4.84)$$

where A_1, B_1, A_2, B_2 and k are all constants.

- Find a relation that the constants A_1, B_1, A_2 and B_2 must satisfy.
- The coefficients A_2 and B_2 (corresponding to the region $x' > a$) are expected to be linearly related to the coefficients A_1 and B_1 (corresponding to the region $x' < -a$)

$$\begin{pmatrix} A_2 \\ B_2 \end{pmatrix} = \begin{pmatrix} M_{11} & M_{12} \\ M_{21} & M_{22} \end{pmatrix} \begin{pmatrix} A_1 \\ B_1 \end{pmatrix} , \quad (4.85)$$

where the matrix elements M_{11}, M_{12}, M_{21} and M_{22} are all constants (explain why). The transmission and reflection coefficients t and r (t' and r') for scattering from right to left (from left to right) are defined by

$$\begin{pmatrix} r \\ 1 \end{pmatrix} = \begin{pmatrix} M_{11} & M_{12} \\ M_{21} & M_{22} \end{pmatrix} \begin{pmatrix} 0 \\ t \end{pmatrix} , \quad (4.86)$$

$$\begin{pmatrix} t' \\ 0 \end{pmatrix} = \begin{pmatrix} M_{11} & M_{12} \\ M_{21} & M_{22} \end{pmatrix} \begin{pmatrix} 1 \\ r' \end{pmatrix} . \quad (4.87)$$

Find relations that the scattering coefficients t , r , t' and r' must satisfy.

- c) Find an additional relation that must be satisfied when the potential $V(x')$ is symmetric, i.e. when $V(x') = V(-x')$.
30. A particle having mass m moves in one dimension under the influence of a rectangular potential barrier given by

$$V(x') = \begin{cases} U_b & |x'| \leq \frac{a}{2} \\ 0 & |x'| > \frac{a}{2} \end{cases} . \quad (4.88)$$

Consider a solution to the time independent Schrödinger equation, whose wavefunction in the range $|x| > a/2$ has the form

$$\psi(x') = \begin{cases} e^{ikx'} + re^{-ikx'} & x' < -\frac{a}{2} \\ te^{ikx'} & x' > \frac{a}{2} \end{cases} , \quad (4.89)$$

where k is a constant. Calculate the transmission and reflection coefficients t and r respectively.

31. **Resonant tunneling** - Consider a one-dimensional double barrier potential. Express the transmission coefficient t in terms of the transmission and reflection coefficients t_n and r_n (t'_n and r'_n) for scattering from right to left (from left to right) of the n 'th barrier, where $n \in \{1, 2\}$, and in terms of the distance l between the left ($n = 1$) and the right ($n = 2$) barriers.
32. **One-dimensional periodic potential** - Consider an array made of N identical potential barriers. The n 'th barrier is located along the x axis at the points $x_n = nl$, where l is the spacing between barriers and $n \in \{0, 1, 2, \dots, N - 1\}$. Each of the N identical barriers is characterized by transmission t and reflection r coefficients (the dependence of t and r on energy is disregarded). In the limit of large N , under what conditions the transmission probability of the array is close to unity?
33. Calculate the Weyl transformation $A(x, p)$ of the classical variable $A(x^{(c)}, p^{(c)}) = p^{(c)}x^{(c)}$.
34. Invert Eq. (4.45), i.e. express the variable $A(x^{(c)}, p^{(c)})$ as a function of the operator $A(x, p)$.
35. **effective Hamiltonian of a subspace** - Consider a system having time independent Hamiltonian \mathcal{H} . Let $|\psi\rangle$ be an energy eigenvector of \mathcal{H} with energy E . i.e.

$$\mathcal{H}|\psi\rangle = E|\psi\rangle . \quad (4.90)$$

Let P be a projection operator onto a subspace \mathcal{F} of the entire Hilbert space of the system. Show that

$$\mathcal{H}_{\text{eff}}|\psi_1\rangle = E|\psi_1\rangle , \quad (4.91)$$

where the state $|\psi_1\rangle$ is the projection of $|\psi\rangle$ onto \mathcal{F} , i.e.

$$|\psi_1\rangle = P|\psi\rangle, \quad (4.92)$$

the effective Hamiltonian \mathcal{H}_{eff} of the subspace is given by

$$\mathcal{H}_{\text{eff}} = \mathcal{H}_{11} + \mathcal{H}_{12}(E - \mathcal{H}_{22})^{-1}\mathcal{H}_{21}, \quad (4.93)$$

where

$$\mathcal{H}_{11} = P\mathcal{H}P, \quad (4.94)$$

$$\mathcal{H}_{22} = Q\mathcal{H}Q, \quad (4.95)$$

$$\mathcal{H}_{12} = P\mathcal{H}Q, \quad (4.96)$$

$$\mathcal{H}_{21} = Q\mathcal{H}P, \quad (4.97)$$

and where

$$Q = 1 - P. \quad (4.98)$$

36. Consider a system having a time-independent Hamiltonian \mathcal{H} . During the time interval $[0, t]$ a given unitary operator U is instantaneously applied at times nt/N , where $n = 1, 2, \dots, N$. Consequently, the system's state vector $|\psi\rangle$ evolves according to

$$|\psi(t)\rangle = (Uu)^N |\psi(0)\rangle, \quad (4.99)$$

where the operator u is given by [see Eq. (4.9)]

$$u = \exp\left(-\frac{i\mathcal{H}t}{\hbar N}\right). \quad (4.100)$$

In terms of the ket vector $|\psi_{\text{I}}(t)\rangle$, which is defined by

$$|\psi_{\text{I}}(t)\rangle = (U^\dagger)^N |\psi(t)\rangle, \quad (4.101)$$

Eq. (4.99) can be rewritten as

$$|\psi_{\text{I}}(t)\rangle = U_{\text{I}} |\psi_{\text{I}}(0)\rangle, \quad (4.102)$$

where U_{I} is given by

$$U_{\text{I}} = (U^\dagger)^N (Uu)^N U^N. \quad (4.103)$$

Derive a Schrödinger equation for the operator U_{I} having the form [see Eq. (4.7)]

$$i\hbar \frac{dU_{\text{I}}}{dt} = \mathcal{H}_{\text{eff}} U_{\text{I}}, \quad (4.104)$$

and find an expression for the effective Hamiltonian \mathcal{H}_{eff} valid in the limit $N \rightarrow \infty$.

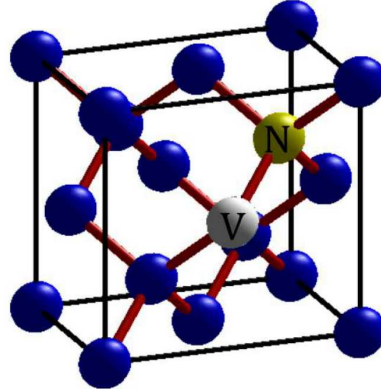

Fig. 4.1. Nitrogen-vacancy (NV) defect in diamond.

37. **nitrogen-vacancy defect in diamond** - The nitrogen-vacancy (NV) defect in diamond consists of an empty lattice site (vacancy) having four nearest neighbors: three carbon (C) atoms and one nitrogen (N) atom (see Fig. 4.1). The empty lattice site gives rise to unpaired electrons forming dangling bonds. Consider the basis of orbital states $\{|\sigma_1\rangle, |\sigma_2\rangle, |\sigma_3\rangle, |\sigma_N\rangle\}$ corresponding to the dangling bonds localized near any of the three C atoms ($|\sigma_1\rangle, |\sigma_2\rangle$ and $|\sigma_3\rangle$ states) and the N one ($|\sigma_N\rangle$ state). In the tight binding model, the matrix representation of the Hamiltonian \mathcal{H} in the basis of orbital states $\{|\sigma_1\rangle, |\sigma_2\rangle, |\sigma_3\rangle, |\sigma_N\rangle\}$ is assumed to be given by

$$\mathcal{H} \doteq \begin{pmatrix} \epsilon_c & \delta_c & \delta_c & \delta_n \\ \delta_c & \epsilon_c & \delta_c & \delta_n \\ \delta_c & \delta_c & \epsilon_c & \delta_n \\ \delta_n & \delta_n & \delta_n & \epsilon_n \end{pmatrix}, \quad (4.105)$$

where ϵ_c , ϵ_n , δ_c and δ_n are all real. In this problem the eigenvectors and eigenvalues of \mathcal{H} are found by using the symmetry properties of the NV defect.

- a) **C_{3v} symmetry** - The elements of the point group symmetry C_{3v} are the identity E , the rotations C_3^\pm around the NV-axis by $\pm 2\pi/3$ radians, and three reflections R_1, R_2 and R_3 , where each of the planes of reflection contains one C atom and the N one. The matrix representation of the six elements $\{I, C_3^+, C_3^-, R_1, R_2, R_3\}$ of the symmetry group C_{3v} in the basis $\{|\sigma_1\rangle, |\sigma_2\rangle, |\sigma_3\rangle, |\sigma_N\rangle\}$ are given by

$$U(E) \doteq \begin{pmatrix} 1 & 0 & 0 & 0 \\ 0 & 1 & 0 & 0 \\ 0 & 0 & 1 & 0 \\ 0 & 0 & 0 & 1 \end{pmatrix}, \quad (4.106)$$

$$U(C_3^+) \doteq \begin{pmatrix} 0 & 0 & 1 & 0 \\ 1 & 0 & 0 & 0 \\ 0 & 1 & 0 & 0 \\ 0 & 0 & 0 & 1 \end{pmatrix}, \quad (4.107)$$

$$U(C_3^-) \doteq \begin{pmatrix} 0 & 1 & 0 & 0 \\ 0 & 0 & 1 & 0 \\ 1 & 0 & 0 & 0 \\ 0 & 0 & 0 & 1 \end{pmatrix}, \quad (4.108)$$

$$U(R_1) \doteq \begin{pmatrix} 1 & 0 & 0 & 0 \\ 0 & 0 & 1 & 0 \\ 0 & 1 & 0 & 0 \\ 0 & 0 & 0 & 1 \end{pmatrix}, \quad (4.109)$$

$$U(R_2) \doteq \begin{pmatrix} 0 & 0 & 1 & 0 \\ 0 & 1 & 0 & 0 \\ 1 & 0 & 0 & 0 \\ 0 & 0 & 0 & 1 \end{pmatrix}, \quad (4.110)$$

$$U(R_3) \doteq \begin{pmatrix} 0 & 1 & 0 & 0 \\ 1 & 0 & 0 & 0 \\ 0 & 0 & 1 & 0 \\ 0 & 0 & 0 & 1 \end{pmatrix}. \quad (4.111)$$

Show that $[\mathcal{U}, \mathcal{H}] = 0$, where $\mathcal{U} \in \{U(E), U(C_3^+), U(C_3^-), U(R_1), U(R_2), U(R_3)\}$.

b) Consider the orthonormal basis $\{|e_x\rangle, |e_y\rangle, |\sigma_N\rangle, |\sigma_C\rangle\}$, where

$$\langle e_x | \doteq \left[\frac{2}{\sqrt{6}} \quad -\frac{1}{\sqrt{6}} \quad -\frac{1}{\sqrt{6}} \quad 0 \right], \quad (4.112)$$

$$\langle e_y | \doteq \left[0 \quad \frac{1}{\sqrt{2}} \quad -\frac{1}{\sqrt{2}} \quad 0 \right], \quad (4.113)$$

$$\langle \sigma_N | \doteq [0 \ 0 \ 0 \ 1], \quad (4.114)$$

$$\langle \sigma_C | \doteq \left[\frac{1}{\sqrt{3}} \quad \frac{1}{\sqrt{3}} \quad \frac{1}{\sqrt{3}} \quad 0 \right]. \quad (4.115)$$

Calculate $U^{-1}\mathcal{U}U$, where $\mathcal{U} \in \{U(E), U(C_3^+), U(C_3^-), U(R_1), U(R_2), U(R_3)\}$, and where U is the unitary transformation to the basis $\{|e_x\rangle, |e_y\rangle, |\sigma_N\rangle, |\sigma_C\rangle\}$.

c) Calculate $U^{-1}\mathcal{H}U$.

4.7 Solutions

1. With the help of Eq. (4.7) one finds that

$$Z = \frac{du}{dt} u^\dagger = (i\hbar)^{-1} \mathcal{H}. \quad (4.116)$$

2. Both A and B are constants of the motion, thus $[A, \mathcal{H}] = 0$ and $[B, \mathcal{H}] = 0$ [see Eq. (4.38)], hence $[O_+, \mathcal{H}] = [O_-, \mathcal{H}] = 0$ [see Eq. (2.145)].
3. The operators S_x, S_y and S_z are given by Eqs. (2.103), (2.104) and (2.100) respectively. The Hamiltonian is given by Eq. (4.21). Using Eqs. (4.38) and (2.137) one has

$$\frac{d\langle S_x \rangle}{dt} = \frac{\omega}{i\hbar} \langle [S_x, S_z] \rangle = -\omega \langle S_y \rangle, \quad (4.117)$$

$$\frac{d\langle S_y \rangle}{dt} = \frac{\omega}{i\hbar} \langle [S_y, S_z] \rangle = \omega \langle S_x \rangle, \quad (4.118)$$

$$\frac{d\langle S_z \rangle}{dt} = \frac{\omega}{i\hbar} \langle [S_z, S_z] \rangle = 0, \quad (4.119)$$

where

$$\omega = \frac{|e|B}{m_e c}. \quad (4.120)$$

At time $t = 0$ the system is in state

$$|+; \hat{\mathbf{x}}\rangle = \frac{1}{\sqrt{2}} (|+\rangle + |-\rangle), \quad (4.121)$$

thus

$$\langle S_x \rangle (t=0) = \frac{\hbar}{4} (\langle +| + \langle -|) (|+\rangle \langle -| + |-\rangle \langle +|) (|+\rangle + |-\rangle) = \frac{\hbar}{2}.$$

$$\langle S_y \rangle (t=0) = \frac{\hbar}{4} (\langle +| + \langle -|) (-i|+\rangle \langle -| + i|-\rangle \langle +|) (|+\rangle + |-\rangle) = 0.$$

$$\langle S_z \rangle (t=0) = \frac{\hbar}{4} (\langle +| + \langle -|) (|+\rangle \langle +| - |-\rangle \langle -|) (|+\rangle + |-\rangle) = 0.$$

The solution is easily found to be given by

$$\langle S_x \rangle (t) = \left(\frac{\hbar}{2}\right) \cos(\omega t), \quad (4.122)$$

$$\langle S_y \rangle (t) = \left(\frac{\hbar}{2}\right) \sin(\omega t), \quad (4.123)$$

$$\langle S_z \rangle (t) = 0. \quad (4.124)$$

4. With the help of Eq. (4.38) one finds that

$$\frac{d\langle P \rangle}{dt} = \frac{1}{i\hbar} \langle \psi | [P, \mathcal{H}] | \psi \rangle. \quad (4.125)$$

where $|\psi\rangle$ is the state of the system. Taking the time derivative of the above relation yields

$$\frac{d^2\langle P \rangle}{dt^2} = \frac{1}{i\hbar} \left[\langle \psi | [P, \mathcal{H}] \frac{d}{dt} | \psi \rangle + \left(\frac{d}{dt} \langle \psi | \right) [P, \mathcal{H}] | \psi \rangle \right], \quad (4.126)$$

or [see Eq. (4.1)]

$$\frac{d^2 \langle P \rangle}{dt^2} = -\frac{1}{\hbar^2} \langle \psi | [[P, \mathcal{H}], \mathcal{H}] | \psi \rangle , \quad (4.127)$$

where the following holds

$$[P, \mathcal{H}] = |\psi_0\rangle \langle \psi_0| \mathcal{H} - \mathcal{H} |\psi_0\rangle \langle \psi_0| , \quad (4.128)$$

$$[[P, \mathcal{H}], \mathcal{H}] = |\psi_0\rangle \langle \psi_0| \mathcal{H}^2 + \mathcal{H}^2 |\psi_0\rangle \langle \psi_0| - 2\mathcal{H} |\psi_0\rangle \langle \psi_0| \mathcal{H} . \quad (4.129)$$

Thus, at time $t = 0$ one has

$$\left. \frac{d \langle P \rangle}{dt} \right|_{t=0} = \frac{1}{i\hbar} (\langle \psi_0 | \mathcal{H} | \psi_0 \rangle - \langle \psi_0 | \mathcal{H} | \psi_0 \rangle) = 0 , \quad (4.130)$$

and

$$\left. \frac{d^2 \langle P \rangle}{dt^2} \right|_{t=0} = -\frac{2}{\hbar^2} \langle (\Delta \mathcal{H})^2 \rangle , \quad (4.131)$$

and therefore to second order in t one has

$$\langle P \rangle = 1 - \frac{\langle (\Delta \mathcal{H})^2 \rangle}{\hbar^2} t^2 + O(t^3) . \quad (4.132)$$

5. The Hamiltonian operator \mathcal{H} is given by

$$\mathcal{H} = \frac{p^2}{2m} + V(x) . \quad (4.133)$$

Multiplying the relation

$$\mathcal{H} |\psi_n\rangle = E_n |\psi_n\rangle \quad (4.134)$$

from the left by $\langle x' |$ yields [see Eqs. (3.23) and (3.29)]

$$-\frac{\hbar^2}{2m} \frac{d^2 \psi_n(x')}{dx'^2} + V(x') \psi_n(x') = E_n \psi_n(x') , \quad (4.135)$$

where

$$\psi_n(x') = \langle x' | \psi_n \rangle \quad (4.136)$$

is the wavefunction in the coordinate representation.

6. Using $[x, p_x] = [y, p_y] = [z, p_z] = i\hbar$ one finds that

$$\begin{aligned} [\mathcal{H}, \mathbf{r}] &= \left[\frac{\mathbf{p}^2}{2m}, \mathbf{r} \right] \\ &= \frac{1}{2m} ([p_x^2, x], [p_y^2, y], [p_z^2, z]) \\ &= \frac{\hbar}{im} (p_x, p_y, p_z) \\ &= \frac{\hbar}{im} \mathbf{p} . \end{aligned} \quad (4.137)$$

Thus

$$\begin{aligned}
 \langle \psi_n | \mathbf{p} | \psi_n \rangle &= \frac{im}{\hbar} \langle \psi_n | [\mathcal{H}, \mathbf{r}] | \psi_n \rangle \\
 &= \frac{im}{\hbar} \langle \psi_n | (\mathcal{H}\mathbf{r} - \mathbf{r}\mathcal{H}) | \psi_n \rangle \\
 &= \frac{imE_n}{\hbar} \langle \psi_n | (\mathbf{r} - \mathbf{r}) | \psi_n \rangle \\
 &= 0 .
 \end{aligned} \tag{4.138}$$

7. Multiplying Eq. (4.56) from the left by the bra $\langle \mathbf{p}' |$ and inserting the closure relation

$$1 = \int d\mathbf{p}'' |\mathbf{p}''\rangle \langle \mathbf{p}''| \tag{4.139}$$

yields

$$i\hbar \frac{d\phi_\alpha(\mathbf{p}')}{dt} = \int d\mathbf{p}'' \langle \mathbf{p}' | \mathcal{H} | \mathbf{p}'' \rangle \phi_\alpha(\mathbf{p}'') . \tag{4.140}$$

The following hold

$$\langle \mathbf{p}' | \mathbf{p}^2 | \mathbf{p}'' \rangle = \mathbf{p}'^2 \delta(\mathbf{p}' - \mathbf{p}'') , \tag{4.141}$$

and

$$\begin{aligned}
 \langle \mathbf{p}' | V(\mathbf{r}) | \mathbf{p}'' \rangle &= \int d\mathbf{r}' \int d\mathbf{r}'' \langle \mathbf{p}' | \mathbf{r}' \rangle \langle \mathbf{r}' | V(\mathbf{r}) | \mathbf{r}'' \rangle \langle \mathbf{r}'' | \mathbf{p}'' \rangle \\
 &= (2\pi\hbar)^{-3} \int d\mathbf{r}' \int d\mathbf{r}'' \exp\left(-\frac{i\mathbf{p}' \cdot \mathbf{r}'}{\hbar}\right) V(\mathbf{r}') \delta(\mathbf{r}' - \mathbf{r}'') \exp\left(\frac{i\mathbf{p}'' \cdot \mathbf{r}''}{\hbar}\right) \\
 &= (2\pi\hbar)^{-3} \int d\mathbf{r}' \exp\left(-\frac{i(\mathbf{p}' - \mathbf{p}'') \cdot \mathbf{r}'}{\hbar}\right) V(\mathbf{r}') \\
 &= U(\mathbf{p}' - \mathbf{p}'') ,
 \end{aligned} \tag{4.142}$$

thus the momentum wave function $\phi_\alpha(\mathbf{p}')$ satisfies the following equation

$$i\hbar \frac{d\phi_\alpha}{dt} = \frac{\mathbf{p}'^2}{2m} \phi_\alpha + \int d\mathbf{p}'' U(\mathbf{p}' - \mathbf{p}'') \phi_\alpha . \tag{4.143}$$

8. The Hamiltonian is given by

$$\mathcal{H} = \frac{\mathbf{p}^2}{2m} + V(\mathbf{r}) . \tag{4.144}$$

Using Eq. (4.38) one has

$$\frac{d\langle x \rangle}{dt} = \frac{1}{i\hbar} \langle [x, \mathcal{H}] \rangle = \frac{1}{i\hbar 2m} \langle [x, p_x^2] \rangle = \frac{\langle p_x \rangle}{m}, \quad (4.145)$$

and

$$\frac{d\langle p_x \rangle}{dt} = \frac{1}{i\hbar} \langle [p_x, V(\mathbf{r})] \rangle, \quad (4.146)$$

or with the help of Eq. (3.76)

$$\frac{d\langle p_x \rangle}{dt} = - \left\langle \frac{\partial V}{\partial x} \right\rangle. \quad (4.147)$$

This together with Eq. (4.145) yield

$$m \frac{d^2 \langle x \rangle}{dt^2} = - \left\langle \frac{\partial V}{\partial x} \right\rangle. \quad (4.148)$$

Similar equations are obtained for $\langle y \rangle$ and $\langle z \rangle$, which together yield Eq. (4.60).

9. Substituting a solution having the form

$$\psi(\mathbf{r}) = \psi_1(x_1) \psi_2(x_2) \psi_3(x_3) \quad (4.149)$$

into the time-independent Schrödinger equation, which is given by

$$\nabla^2 \psi(\mathbf{r}) + \frac{2m}{\hbar^2} [E - V(\mathbf{r})] \psi(\mathbf{r}) = 0, \quad (4.150)$$

and dividing by $\psi(\mathbf{r})$ yield

$$\sum_{i=1}^3 \left(\frac{1}{\psi_i(x_i)} \frac{d^2 \psi_i(x_i)}{dx_i^2} - \frac{2m}{\hbar^2} V_i(x_i) \right) = -\frac{2m}{\hbar^2} E. \quad (4.151)$$

In the sum, the i 'th term ($i \in \{1, 2, 3\}$) depends only on x_i , thus each term must be a constant

$$\frac{1}{\psi_i(x_i)} \frac{d^2 \psi_i(x_i)}{dx_i^2} - \frac{2m}{\hbar^2} V_i(x_i) = -\frac{2m}{\hbar^2} E_i, \quad (4.152)$$

where $E_1 + E_2 + E_3 = E$.

10. Consider two eigen-wave-functions $\psi_1(x)$ and $\psi_2(x)$ having the same eigenenergy E . The following holds

$$\frac{d^2 \psi_1}{dx^2} + \frac{2m}{\hbar^2} (E - V(x)) \psi_1 = 0, \quad (4.153)$$

$$\frac{d^2 \psi_2}{dx^2} + \frac{2m}{\hbar^2} (E - V(x)) \psi_2 = 0, \quad (4.154)$$

thus

$$\frac{1}{\psi_1} \frac{d^2\psi_1}{dx^2} = \frac{1}{\psi_2} \frac{d^2\psi_2}{dx^2}, \quad (4.155)$$

or

$$\psi_2 \frac{d^2\psi_1}{dx^2} - \psi_1 \frac{d^2\psi_2}{dx^2} = \frac{d}{dx} \left(\psi_2 \frac{d\psi_1}{dx} - \psi_1 \frac{d\psi_2}{dx} \right) = 0, \quad (4.156)$$

therefore

$$\psi_2 \frac{d\psi_1}{dx} - \psi_1 \frac{d\psi_2}{dx} = C, \quad (4.157)$$

where C is a constant. However, for bound states

$$\lim_{x \rightarrow \pm\infty} \psi(x) = 0, \quad (4.158)$$

thus $C = 0$, and consequently

$$\frac{1}{\psi_1} \frac{d\psi_1}{dx} = \frac{1}{\psi_2} \frac{d\psi_2}{dx}. \quad (4.159)$$

Integrating the above equation yields

$$\log \psi_1 = \log \psi_2 + \alpha, \quad (4.160)$$

where α is a constant. Therefore

$$\psi_1 = e^\alpha \psi_2, \quad (4.161)$$

and therefore ψ_2 is just proportional to ψ_1 (both represent the same physical state).

11. Consider two eigen-wave-functions $\psi_n(x)$ and $\psi_{n+1}(x)$ with $E_n < E_{n+1}$. As we saw in the previous exercise, the spectrum is non-degenerate. Moreover, the Schrödinger equation

$$\frac{d^2\psi}{dx^2} + \frac{2m}{\hbar^2} (E - V(x)) \psi = 0, \quad (4.162)$$

which the eigen-wave-functions satisfy, is real. Therefore given that $\psi(x)$ is a solution with a given eigenenergy E , then also $\psi^*(x)$ is a solution with the same E . Therefore, all eigen-wave-functions can be chosen to be real (i.e., by the transformation $\psi(x) \rightarrow (\psi(x) + \psi^*(x))/2$). We have

$$\frac{d^2\psi_n}{dx^2} + \frac{2m}{\hbar^2} (E_n - V(x)) \psi_n = 0, \quad (4.163)$$

$$\frac{d^2\psi_{n+1}}{dx^2} + \frac{2m}{\hbar^2} (E_{n+1} - V(x)) \psi_{n+1} = 0. \quad (4.164)$$

By multiplying the first Eq. by ψ_{n+1} , the second one by ψ_n , and subtracting one has

$$\psi_{n+1} \frac{d^2 \psi_n}{dx^2} - \psi_n \frac{d^2 \psi_{n+1}}{dx^2} + \frac{2m}{\hbar^2} (E_n - E_{n+1}) \psi_n \psi_{n+1} = 0, \quad (4.165)$$

or

$$\frac{d}{dx} \left(\psi_{n+1} \frac{d\psi_n}{dx} - \psi_n \frac{d\psi_{n+1}}{dx} \right) + \frac{2m}{\hbar^2} [E_n - E_{n+1}] \psi_n \psi_{n+1} = 0. \quad (4.166)$$

Let x_1 and x_2 be two consecutive zeros of $\psi_n(x)$ (i.e., $\psi_n(x_1) = \psi_n(x_2) = 0$). Integrating from x_1 to x_2 yields

$$\left(\psi_{n+1} \frac{d\psi_n}{dx} - \underbrace{\psi_n}_{=0} \frac{d\psi_{n+1}}{dx} \right) \Big|_{x_1}^{x_2} = \frac{2m}{\hbar^2} \underbrace{(E_{n+1} - E_n)}_{>0} \int_{x_1}^{x_2} dx \psi_n \psi_{n+1}. \quad (4.167)$$

Without loss of generality, assume that $\psi_n(x) > 0$ in the range (x_1, x_2) . Since $\psi_n(x)$ is expected to be continuous, the following must hold

$$\left. \frac{d\psi_n}{dx} \right|_{x=x_1} > 0, \quad (4.168)$$

$$\left. \frac{d\psi_n}{dx} \right|_{x=x_2} < 0. \quad (4.169)$$

As can be clearly seen from Eq. (4.167), the assumption that $\psi_{n+1}(x) > 0$ in the entire range (x_1, x_2) leads to contradiction. Similarly, the possibility that $\psi_{n+1}(x) < 0$ in the entire range (x_1, x_2) is excluded. Therefore, ψ_{n+1} must have at least one zero in this range.

12. Clearly if $\psi(x)$ is an eigen function with energy E , also $\psi(-x)$ is an eigen function with the same energy. Consider two cases: (i) The level E is non-degenerate. For this case $\psi(x) = c\psi(-x)$, where c is a constant. Normalization requires that $|c|^2 = 1$. Moreover, since the wavefunctions can be chosen to be real, the following holds: $\psi(x) = \pm\psi(-x)$. (ii) The level E is degenerate. For this case every superposition of $\psi(x)$ and $\psi(-x)$ can be written as a superposition of an odd eigen function $\psi_{\text{odd}}(x)$ and an even one $\psi_{\text{even}}(x)$, which are defined by

$$\psi_{\text{odd}}(x) = \psi(x) - \psi(-x), \quad (4.170)$$

$$\psi_{\text{even}}(x) = \psi(x) + \psi(-x). \quad (4.171)$$

13. The time-independent Schrödinger equation reads [see Eq. (4.62)]

$$\frac{d^2 \psi(x)}{dx^2} + \frac{2m}{\hbar^2} (E - V(x)) \psi(x) = 0. \quad (4.172)$$

Assume $V(x)$ has a finite discontinuity at $x = x_0$. Integrating the Schrödinger equation in the interval $(x_0 - \varepsilon, x_0 + \varepsilon)$ yields

$$\left(\frac{d\psi(x)}{dx} \right) \Big|_{x_0-\varepsilon}^{x_0+\varepsilon} = \frac{2m}{\hbar^2} \int_{x_0-\varepsilon}^{x_0+\varepsilon} (V(x) - E) \psi(x) dx = 0. \quad (4.173)$$

In the limit $\varepsilon \rightarrow 0$ the right hand side vanishes (assuming $\psi(x)$ is bounded). Therefore $d\psi(x)/dx$ is continuous at $x = x_0$.

14. Since $V_s(-x) = V_s(x)$ the ground state wavefunction is expected to be an even function of x . Consider a solution having an energy E and a wavefunction of the form

$$\psi(x) = \begin{cases} Ae^{-\gamma x} & \text{if } x > a \\ B \cos(kx) & \text{if } -a \leq x \leq a \\ Ae^{\gamma x} & \text{if } x < -a \end{cases}, \quad (4.174)$$

where

$$\gamma = \frac{\sqrt{-2mE}}{\hbar}, \quad (4.175)$$

and

$$k = \frac{\sqrt{2m(W + E)}}{\hbar}. \quad (4.176)$$

Requiring that both $\psi(x)$ and $d\psi(x)/dx$ are continuous at $x = a$ yields

$$Ae^{-\gamma a} = B \cos(ka), \quad (4.177)$$

and

$$-\gamma Ae^{-\gamma a} = -kB \sin(ka), \quad (4.178)$$

or in a matrix form

$$C \begin{pmatrix} A \\ B \end{pmatrix} = \begin{pmatrix} 0 \\ 0 \end{pmatrix}, \quad (4.179)$$

where

$$C = \begin{pmatrix} e^{-\gamma a} & -\cos(ka) \\ -\gamma e^{-\gamma a} & k \sin(ka) \end{pmatrix}. \quad (4.180)$$

A nontrivial solution exists iff $\text{Det}(C) = 0$, namely iff

$$\frac{\gamma}{k} = \tan(ka). \quad (4.181)$$

This condition can be rewritten using Eqs. (4.175) and (4.176) and the dimensionless parameters

$$K = ka, \quad (4.182)$$

$$K_0 = \frac{\sqrt{2mW}}{\hbar} a, \quad (4.183)$$

as

$$\cos^2 K = \frac{1}{1 + \tan^2 K} = \frac{1}{1 + \left(\frac{K}{k}\right)^2} = \left(\frac{K}{K_0}\right)^2. \quad (4.184)$$

Note, however, that according to Eq. (4.181) $\tan K > 0$. Thus, Eq. (4.181) is equivalent to the set of equations

$$|\cos K| = \frac{K}{K_0}, \quad (4.185)$$

$$\tan K > 0. \quad (4.186)$$

This set has at least one solution (this can be seen by plotting the functions $|\cos K|$ and K/K_0).

15. Final answers: (a) $|a_1|^2 + |a_2|^2$. (b)

$$\Delta E = \frac{\pi^2 \hbar^2}{2ma^2} \sqrt{\sum_{n=1}^3 |a_n|^2 n^4 - \left(\sum_{n=1}^3 |a_n|^2 n^2\right)^2}. \quad (4.187)$$

(c) The same as at $t = 0$. (d) $\langle E \rangle = 2\pi^2 \hbar^2 / (ma^2)$, $\langle \Delta E \rangle = 0$.

16. With the help of the identities

$$\sin^3 \alpha = \frac{3 \sin \alpha}{4} - \frac{\sin(3\alpha)}{4}, \quad (4.188)$$

and

$$\int_0^a dx \sin^6 \frac{\pi x}{a} = \frac{5a}{16}, \quad (4.189)$$

one finds that $\psi(t=0)$ can be expressed as

$$\psi(t=0) = \sqrt{\frac{1}{5a}} \left(3 \sin \frac{\pi x}{a} - \sin \frac{3\pi x}{a} \right), \quad (4.190)$$

and thus [see Eqs. (4.254), (4.255) and (4.9)]

$$\psi(t) = \sqrt{\frac{1}{5a}} \left(3e^{-i\Omega t} \sin \frac{\pi x}{a} - e^{-9i\Omega t} \sin \frac{3\pi x}{a} \right), \quad (4.191)$$

where

$$\Omega = \frac{\pi^2 \hbar}{2ma^2}. \quad (4.192)$$

17. With the help of the Schrödinger equation [see Eq. (4.62)]

$$\frac{d^2\psi}{dx'^2} + \frac{2m}{\hbar^2} (E - V(x'))\psi = 0, \quad (4.193)$$

one finds that

$$\begin{aligned} V(x') - E &= \frac{\hbar^2}{2m} \frac{d^2\psi}{dx'^2} \frac{1}{\psi} \\ &= \frac{\hbar^2}{2mx_0^2} \left(1 - 4 \left(\frac{x'}{x_0} \right)^{-1} + 2 \left(\frac{x'}{x_0} \right)^{-2} \right). \end{aligned} \quad (4.194)$$

18. The Schrödinger equation for the wavefunction $\psi(x)$ is given by [see Eq. (4.62)]

$$\left(\frac{d^2}{dx^2} + \frac{2m}{\hbar^2} E \right) \psi(x) = 0. \quad (4.195)$$

The boundary conditions at $x = 0$ are [see Eq. (4.173)]

$$\psi(0^+) = \psi(0^-), \quad (4.196)$$

$$\frac{d\psi(0^+)}{dx} - \frac{d\psi(0^-)}{dx} = -\frac{2}{a_0} \psi(0), \quad (4.197)$$

where

$$a_0 = \frac{\hbar^2}{m\alpha}. \quad (4.198)$$

Due to symmetry $V(x) = V(-x)$ the solutions are expected to have definite symmetry (even $\psi(x) = \psi(-x)$ or odd $\psi(x) = -\psi(-x)$). For the ground state, which is expected to have even symmetry, we consider a wavefunction having the form

$$\psi(x) = Ae^{-\kappa|x|}, \quad (4.199)$$

where A is a normalization constants and where

$$\kappa = \frac{\sqrt{-2mE}}{\hbar}. \quad (4.200)$$

The parameter κ is real for $E < 0$. This even wavefunction satisfies the Schrödinger equation for $x \neq 0$ and the boundary condition (4.196). The condition (4.197) leads to a single solution for the energy of the ground state

$$E = -\frac{m\alpha^2}{2\hbar^2}. \quad (4.201)$$

Thus the normalized wavefunction of the ground state $\psi_0(x)$ is given by

$$\psi_{0,\alpha}(x) = \sqrt{\frac{m\alpha}{\hbar^2}} \exp\left(-\frac{m\alpha}{\hbar^2}|x|\right). \quad (4.202)$$

The probability p that the particle will remain bounded is given by

$$\begin{aligned} p &= \left| \int_{-\infty}^{\infty} \psi_{0,\alpha_1}^*(x) \psi_{0,\alpha_2}(x) dx \right|^2 \\ &= \frac{4m^2\alpha_1\alpha_2}{\hbar^4} \left| \int_0^{\infty} \exp\left(-\frac{m(\alpha_1 + \alpha_2)}{\hbar^2}x\right) dx \right|^2 \\ &= \frac{4\alpha_1\alpha_2}{(\alpha_1 + \alpha_2)^2}. \end{aligned} \quad (4.203)$$

19. The normalized wavefunction of the ground state is given by [see Eq. (4.202)]

$$\psi_0(x) = \sqrt{\frac{m\alpha}{\hbar^2}} \exp\left(-\frac{m\alpha}{\hbar^2}|x|\right). \quad (4.204)$$

Thus, the probability $s(p_0)$ is given by

$$\begin{aligned} s(p_0) &= \left| \langle \gamma_0 | \exp\left(\frac{ip_0x}{\hbar}\right) | \gamma_0 \rangle \right|^2 \\ &= \left| \frac{m\alpha}{\hbar^2} \int_{-\infty}^{\infty} \exp\left(\frac{ip_0x}{\hbar}\right) \exp\left(-\frac{2m\alpha}{\hbar^2}|x|\right) dx \right|^2 \\ &= \frac{1}{\left(1 + \frac{\hbar^2 p_0^2}{4m^2\alpha^2}\right)^2}. \end{aligned} \quad (4.205)$$

20. The normalized position wavefunction of the ground state $\psi_0(x')$ is given by Eq. (4.202), thus with the help of Eq. (3.60) one finds that

$$\begin{aligned} \phi_0(p') &= \frac{\int_{-\infty}^{\infty} dx' e^{-\frac{ip'x'}{\hbar}} \psi_0(x')}{\sqrt{2\pi\hbar}} \\ &= \sqrt{\frac{m\alpha}{2\pi\hbar^3}} \int_{-\infty}^{\infty} dx' e^{-\frac{ip'x'}{\hbar}} \exp\left(-\frac{m\alpha}{\hbar^2}|x'|\right) \\ &= \frac{\sqrt{\frac{2\hbar}{\pi m\alpha}}}{1 + \left(\frac{\hbar p'}{m\alpha}\right)^2}. \end{aligned} \quad (4.206)$$

Alternatively, $\phi_0(p')$ can be found by solving the integro-differential equation [see Eq. (4.58)]

$$\frac{p'^2}{2m}\phi_0(p') + \int dp'' U(p' - p'')\phi_0(p'') = E\phi_0(p') , \quad (4.207)$$

where $U(p')$ is given by [see Eq. (4.59)]

$$\begin{aligned} U(p') &= \frac{1}{2\pi\hbar} \int_{-\infty}^{\infty} dx' V(x') \exp\left(-\frac{ip'x'}{\hbar}\right) \\ &= -\frac{\alpha}{2\pi\hbar} \int_{-\infty}^{\infty} dx' \delta(x') \exp\left(-\frac{ip'x'}{\hbar}\right) \\ &= -\frac{\alpha}{2\pi\hbar} , \end{aligned} \quad (4.208)$$

and E is an energy eigenvalue, thus

$$\frac{p'^2}{2m}\phi_0(p') - \frac{\alpha}{2\pi\hbar}I = E\phi_0(p') , \quad (4.209)$$

where

$$I = \int_{-\infty}^{\infty} dp' \phi_0(p') , \quad (4.210)$$

or [see Eq. (4.209)]

$$\phi_0(p') = \frac{\frac{\alpha I}{2\pi\hbar}}{\frac{p'^2}{2m} - E} . \quad (4.211)$$

Rewriting Eq. (4.210) using Eq. (4.211) leads to

$$I = \int_{-\infty}^{\infty} dp' \phi_0(p') = \frac{\alpha I}{2\pi\hbar} \pi \sqrt{\frac{2m}{-E}} , \quad (4.212)$$

thus the unique solution for E is given by

$$E = -\frac{m\alpha^2}{2\hbar^2} , \quad (4.213)$$

hence [see Eqs. (4.211) and (4.213)]

$$\phi_0(p') = \frac{C}{1 + \left(\frac{\hbar p'}{m\alpha}\right)^2} . \quad (4.214)$$

The normalization condition C is found from the normalization condition

$$1 = \int_{-\infty}^{\infty} dp' |\phi_0(p')|^2 = \frac{\pi m \alpha}{2\hbar} |C|^2, \quad (4.215)$$

thus

$$\phi_0(p') = \frac{\sqrt{\frac{2\hbar}{\pi m \alpha}}}{1 + \left(\frac{\hbar p'}{m\alpha}\right)^2}, \quad (4.216)$$

in agreement with Eq. (4.206).

21. Consider a bound solution having energy $E < 0$, and let [compare with Eq. (4.200)]

$$\kappa = \frac{\sqrt{-2mE}}{\hbar}. \quad (4.217)$$

The symmetry $V(x) = V(-x)$ implies that the solutions of the Schrödinger equation (4.62) can be chosen to have definite symmetry. For an even solution having the form [see Eq. (4.62)]

$$\psi(x) = \begin{cases} e^{\kappa x} & x < -a \\ A \cosh(\kappa x) & |x| < a \\ e^{-\kappa x} & x > a \end{cases}, \quad (4.218)$$

where A is a constant, the boundary conditions (4.196) and (4.197) at $x = \pm a$ yield

$$e^{-\kappa a} = A \cosh(\kappa a), \quad (4.219)$$

$$-\kappa e^{-\kappa a} - A\kappa \sinh(\kappa a) = -\frac{2}{a_0} e^{-\kappa a}, \quad (4.220)$$

where

$$a_0 = \frac{\hbar^2}{m\alpha}, \quad (4.221)$$

thus

$$\kappa a_0 = 1 + e^{-2\kappa a}. \quad (4.222)$$

Similarly, for an odd solution having the form

$$\psi(x) = \begin{cases} e^{\kappa x} & x < -a \\ A \sinh(\kappa x) & |x| < a \\ -e^{-\kappa x} & x > a \end{cases}, \quad (4.223)$$

the boundary conditions (4.196) and (4.197) at $x = \pm a$ yield

$$-e^{-\kappa a} = A \sinh(\kappa a), \quad (4.224)$$

$$\kappa e^{-\kappa a} - A\kappa \cosh(\kappa a) = \frac{2}{a_0} e^{-\kappa a}, \quad (4.225)$$

thus

$$\kappa a_0 = 1 - e^{-2\kappa a} . \quad (4.226)$$

While Eq. (4.222) for the even case has a unique solution for any $a > 0$, Eq. (4.226) for the odd case has a unique solution if $|a| > a_0/2$, and no (positive) solution otherwise.

22. The Schrödinger equation for the wavefunction $\psi(x)$ is given by

$$\left[\frac{d^2}{dx^2} + \frac{2m}{\hbar^2} (E - V) \right] \psi(x) = 0 . \quad (4.227)$$

The boundary conditions imposed upon $\psi(x)$ by the potential are [see Eq. (4.173)]

$$\psi(\pm a) = 0 , \quad (4.228)$$

$$\psi(0^+) = \psi(0^-) , \quad (4.229)$$

$$\frac{d\psi(0^+)}{dx} - \frac{d\psi(0^-)}{dx} = -\frac{2}{a_0} \psi(0) , \quad (4.230)$$

where

$$a_0 = \frac{\hbar^2}{m\alpha} . \quad (4.231)$$

Due to symmetry $V(x) = V(-x)$ the solutions are expected to have definite symmetry (even $\psi(x) = \psi(-x)$ or odd $\psi(x) = -\psi(-x)$). For the ground state, which is expected to have even symmetry, we consider a wavefunction having the form

$$\psi(x) = \begin{cases} A \sinh(\kappa(x-a)) & x > 0 \\ -A \sinh(\kappa(x+a)) & x < 0 \end{cases} , \quad (4.232)$$

where A is a normalization constants and where

$$\kappa = \frac{\sqrt{-2mE_0}}{\hbar} . \quad (4.233)$$

The parameter κ is real for $E_0 < 0$. This even wavefunction satisfies Eq. (4.227) for $x \neq 0$ and the boundary conditions (4.228) and (4.229). The condition (4.230) reads

$$\kappa a_0 = \tanh(\kappa a) . \quad (4.234)$$

Nontrivial ($\kappa \neq 0$) real solution exists only when $a > a_0$, thus $E_0 < 0$ iff

$$a > a_0 = \frac{\hbar^2}{m\alpha} . \quad (4.235)$$

23. For the present case the boundary conditions imposed upon $\psi(x)$ by the potential are [see Eq. (4.173)]

$$\psi(0) = 0, \quad (4.236)$$

$$\psi(x_0^+) = \psi(x_0^-), \quad (4.237)$$

$$\frac{d\psi(x_0^+)}{dx} - \frac{d\psi(x_0^-)}{dx} = -\frac{2}{a_0}\psi(x_0), \quad (4.238)$$

where

$$a_0 = \frac{\hbar^2}{m\alpha}. \quad (4.239)$$

Consider a solution having the form

$$\psi(x) = \begin{cases} A \sinh(\kappa x) + B \cosh(\kappa x) & 0 \leq x < x_0 \\ e^{-\kappa(x-x_0)} & x > x_0 \end{cases}, \quad (4.240)$$

where

$$\kappa = \frac{\sqrt{-2mE_0}}{\hbar}. \quad (4.241)$$

The boundary conditions yield

$$B = 0, \quad (4.242)$$

$$1 = A \sinh(\kappa x_0), \quad (4.243)$$

$$-\kappa(1 + A \cosh(\kappa x_0)) = -\frac{2}{a_0}, \quad (4.244)$$

thus

$$\kappa x_0(1 + \coth(\kappa x_0)) = \frac{2x_0}{a_0}. \quad (4.245)$$

Note that for $x \geq 0$ the following holds $x(1 + \coth x) \geq 1$, thus a solution with $E_0 < 0$ (i.e. a solution with a real positive κ) is possible only if

$$\frac{2x_0}{a_0} \geq 1, \quad (4.246)$$

or

$$x_0 \geq \frac{\hbar^2}{2m\alpha}. \quad (4.247)$$

24. Using Eq. (4.37) one has

$$\frac{dx^{(H)}}{dt} = \frac{1}{i\hbar} [x^{(H)}, \mathcal{H}], \quad (4.248)$$

therefore

$$\langle k | \frac{dx^{(H)}}{dt} | l \rangle = \frac{1}{i\hbar} \langle k | x^{(H)} \mathcal{H} - \mathcal{H} x^{(H)} | l \rangle = \frac{i(E_k - E_l)}{\hbar} \langle k | x^{(H)} | l \rangle . \quad (4.249)$$

Integrating yields

$$\langle k | x^{(H)}(t) | l \rangle = \langle k | x^{(H)}(t=0) | l \rangle \exp\left(\frac{i(E_k - E_l)t}{\hbar}\right) . \quad (4.250)$$

Using this result one has

$$\begin{aligned} & \sum_k (E_k - E_l) |\langle k | x | l \rangle|^2 \\ &= \sum_k (E_k - E_l) \left| \langle k | x^{(H)} | l \rangle \right|^2 \\ &= \sum_k (E_k - E_l) \langle k | x^{(H)} | l \rangle \langle l | x^{(H)} | k \rangle \\ &= \frac{\hbar}{2i} \sum_k \left(\langle k | \frac{dx^{(H)}}{dt} | l \rangle \langle l | x^{(H)} | k \rangle - \langle k | x^{(H)} | l \rangle \langle l | \frac{dx^{(H)}}{dt} | k \rangle \right) \\ &= \frac{\hbar}{2i} \sum_k \left(\langle l | x^{(H)} | k \rangle \langle k | \frac{dx^{(H)}}{dt} | l \rangle - \langle l | \frac{dx^{(H)}}{dt} | k \rangle \langle k | x^{(H)} | l \rangle \right) \\ &= \frac{\hbar}{2i} \langle l | x^{(H)} \frac{dx^{(H)}}{dt} - \frac{dx^{(H)}}{dt} x^{(H)} | l \rangle . \end{aligned} \quad (4.251)$$

Using again Eq. (4.37) one has

$$\frac{dx^{(H)}}{dt} = \frac{1}{i\hbar} [x^{(H)}, \mathcal{H}] = \frac{p_x^{(H)}}{m} , \quad (4.252)$$

therefore

$$\begin{aligned} \sum_k (E_k - E_l) |\langle k | x | l \rangle|^2 &= \frac{\hbar}{2im} \langle l | [x^{(H)}, p_x^{(H)}] | l \rangle \\ &= \frac{\hbar}{2im} i\hbar \\ &= \frac{\hbar^2}{2m} . \end{aligned} \quad (4.253)$$

25. The wavefunctions of the normalized eigenstates are given by

$$\psi_n(x) = \sqrt{\frac{2}{a}} \sin \frac{n\pi x}{a} , \quad (4.254)$$

and the corresponding eigenenergies are

$$E_n = \frac{\pi^2 \hbar^2 n^2}{2ma^2}. \quad (4.255)$$

- a) The wavefunction after the measurement is a normalized wavepacket centered at $x = a/2$ and having a width Δx

$$\psi(x) = \begin{cases} \frac{1}{\sqrt{\Delta x}} & |x - \frac{a}{2}| \leq \frac{\Delta x}{2} \\ 0 & \text{else} \end{cases}. \quad (4.256)$$

Thus in the limit $\Delta x \ll a$

$$p_n = \left| \int_0^a dx \psi_n^*(x) \psi(x) \right|^2 \simeq 2 \frac{\Delta x}{a} \sin^2 \frac{n\pi}{2}. \quad (4.257)$$

Namely, $p_n = 0$ for all even n , and the probability of all energies with odd n is equal.

- b) Generally, for every bound state in one dimension $\langle p \rangle = 0$ [see Eq. (4.55)].
26. For a well of width a the wavefunctions of the normalized eigenstates are given by

$$\psi_n^{(a)}(x) = \sqrt{\frac{2}{a}} \sin \frac{n\pi x}{a}, \quad (4.258)$$

and the corresponding eigenenergies are

$$E_n^{(a)} = \frac{\hbar^2 \pi^2 n^2}{2ma^2}. \quad (4.259)$$

- (a) The probability is given by

$$p = \left| \int_0^a dx \psi_1^{(a)}(x) \psi_1^{(2a)}(x) \right|^2 = \frac{32}{9\pi^2}. \quad (4.260)$$

(b) For times $t < 0$ it is given that $\langle \mathcal{H} \rangle = E_1^{(a)}$. Immediately after the change ($t = 0^+$) the wavefunction remains unchanged. A direct evaluation of $\langle \mathcal{H} \rangle$ using the new Hamiltonian yields the same result $\langle \mathcal{H} \rangle = E_1^{(a)}$ as for $t < 0$. At later times $t > 0$ the expectation value $\langle \mathcal{H} \rangle$ remains unchanged due to energy conservation.

27. The wavefunctions of the normalized eigenstates are given by [see Eq. (4.255)]

$$\psi_n(x) = \sqrt{\frac{2}{a}} \sin \frac{n\pi x}{a}, \quad (4.261)$$

and the corresponding eigenenergies are [see Eq. (4.254)]

$$E_n = \frac{\pi^2 \hbar^2 n^2}{2ma^2}, \quad (4.262)$$

where $n = 1, 2, \dots$. By symmetry for all states $\langle x \rangle = a/2$. Furthermore, for all states $\langle p \rangle = 0$ [see Eq. (4.55)]. For the n 'th state the following holds

$$\langle x^2 \rangle = \frac{2}{a} \int_0^a dx' x'^2 \sin^2 \frac{n\pi x'}{a} = \frac{a^2 (2n^2\pi^2 - 3)}{6n^2\pi^2}, \quad (4.263)$$

thus

$$\langle (\Delta x)^2 \rangle = \langle x^2 \rangle - \langle x \rangle^2 = a^2 \left(\frac{1}{12} - \frac{1}{2n^2\pi^2} \right)$$

and [see Eq. (3.29)]

$$\langle (\Delta p)^2 \rangle = \langle p^2 \rangle = \frac{2}{a} \left(\frac{n\pi\hbar}{a} \right)^2 \int_0^a dx' \sin^2 \frac{n\pi x'}{a} = \left(\frac{n\pi\hbar}{a} \right)^2, \quad (4.264)$$

thus [compare with the uncertainty principle (3.10)]

$$\langle (\Delta x)^2 \rangle \langle (\Delta p)^2 \rangle = \frac{\hbar^2}{4} \left(\frac{n^2\pi^2}{3} - 2 \right). \quad (4.265)$$

28. The Schrödinger equation is given by

$$i\hbar \frac{d|\alpha\rangle}{dt} = \mathcal{H}|\alpha\rangle, \quad (4.266)$$

where the Hamiltonian is given by [see Eq. (1.62)]

$$\mathcal{H} = \frac{(\mathbf{p} - \frac{q}{c}\mathbf{A})^2}{2m} + q\varphi. \quad (4.267)$$

Multiplying from the left by $\langle x' |$ yields

$$i\hbar \frac{d\psi}{dt} = \frac{1}{2m} \left(-i\hbar\nabla - \frac{q}{c}\mathbf{A} \right)^2 \psi + q\varphi\psi, \quad (4.268)$$

where

$$\psi = \psi(x') = \langle x' | \alpha \rangle. \quad (4.269)$$

Multiplying Eq. (4.268) by ψ^* , and subtracting the complex conjugate of Eq. (4.268) multiplied by ψ yields

$$i\hbar \frac{d\rho}{dt} = \frac{1}{2m} \left[\psi^* \left(-i\hbar\nabla - \frac{q}{c}\mathbf{A} \right)^2 \psi - \psi \left(i\hbar\nabla - \frac{q}{c}\mathbf{A} \right)^2 \psi^* \right], \quad (4.270)$$

where

$$\rho = \psi\psi^* \quad (4.271)$$

is the probability distribution function. Moreover, the following holds

$$\begin{aligned}
& \psi^* \left(-i\hbar \nabla - \frac{q}{c} \mathbf{A} \right)^2 \psi - \psi \left(i\hbar \nabla - \frac{q}{c} \mathbf{A} \right)^2 \psi^* \\
&= \psi^* \left(-\hbar^2 \nabla^2 + \left(\frac{q}{c} \right)^2 \mathbf{A}^2 + \frac{i\hbar q}{c} \nabla \mathbf{A} + \frac{i\hbar q}{c} \mathbf{A} \nabla \right) \psi \\
&\quad - \psi \left(-\hbar^2 \nabla^2 + \left(\frac{q}{c} \right)^2 \mathbf{A}^2 - \frac{i\hbar q}{c} \nabla \mathbf{A} - \frac{i\hbar q}{c} \mathbf{A} \nabla \right) \psi^* \\
&= -\hbar^2 (\psi^* \nabla^2 \psi - \psi \nabla^2 \psi^*) \\
&\quad + \frac{i\hbar q}{c} (\psi^* \nabla \mathbf{A} \psi + \psi^* \mathbf{A} \nabla \psi + \psi \nabla \mathbf{A} \psi^* + \psi \mathbf{A} \nabla \psi^*) \\
&= -\hbar^2 \nabla (\psi^* \nabla \psi - \psi \nabla \psi^*) + \frac{i\hbar q}{c} \nabla (\psi^* \mathbf{A} \psi + \psi \mathbf{A} \psi^*) .
\end{aligned} \tag{4.272}$$

Thus, Eq. (4.270) can be written as

$$\frac{d\rho}{dt} + \nabla \mathbf{J} = 0 , \tag{4.273}$$

where

$$\mathbf{J} = \frac{\hbar}{m} \text{Im} (\psi^* \nabla \psi) - \frac{q\rho}{mc} \mathbf{A} . \tag{4.274}$$

29. The current density J [see Eq. (4.83)] that is associated with the wavefunction $\psi(x') = Ae^{ikx'} + Be^{-ikx'}$ is given by

$$\begin{aligned}
J &= \frac{\hbar}{m} \text{Im} \left(\psi^* \frac{\partial}{\partial x'} \psi \right) \\
&= \frac{\hbar}{m} \text{Im} \left(ik \left(A^* e^{-ikx'} + B^* e^{ikx'} \right) \left(Ae^{ikx'} - Be^{-ikx'} \right) \right) \\
&= \frac{\hbar}{m} \text{Im} \left(ik \left(|A|^2 - |B|^2 + AB^* e^{2ikx'} - A^* B e^{-2ikx'} \right) \right) \\
&= \frac{\hbar k}{m} \left(|A|^2 - |B|^2 \right) .
\end{aligned} \tag{4.275}$$

- a) Thus for a solution to the time independent Schrödinger equation, for which the current density $\rho = \psi\psi^*$ is time independent, the continuity equation (4.81) yields the relation

$$|A_1|^2 - |B_1|^2 = |A_2|^2 - |B_2|^2 . \tag{4.276}$$

- b) The relation (4.276) implies that [see Eqs. (4.86) and (4.87)]

$$|r|^2 + |t|^2 = |r'|^2 + |t'|^2 = 1 . \tag{4.277}$$

The scattering matrix can be expressed in terms of the coefficients t , r , t' and r' as [see Eqs. (4.86) and (4.87)]

$$\begin{pmatrix} M_{11} & M_{12} \\ M_{21} & M_{22} \end{pmatrix} = \begin{pmatrix} t' - \frac{rr'}{t} & \frac{r}{t} \\ -\frac{r'}{t} & \frac{1}{t} \end{pmatrix}. \quad (4.278)$$

In general, as can be seen from the time independent Schrödinger equation

$$\frac{d^2\psi(x')}{dx'^2} + \frac{2m}{\hbar^2}(E - V(x'))\psi(x') = 0, \quad (4.279)$$

if $\psi(x')$ is a solution, then $\psi^*(x')$ is a solution as well. This property for the current case implies that if Eq. (4.85) holds then the following must hold as well [see Eq. (4.84)]

$$\begin{pmatrix} B_2^* \\ A_2^* \end{pmatrix} = \begin{pmatrix} M_{11} & M_{12} \\ M_{21} & M_{22} \end{pmatrix} \begin{pmatrix} B_1^* \\ A_1^* \end{pmatrix}, \quad (4.280)$$

which implies that

$$\begin{aligned} \begin{pmatrix} A_2 \\ B_2 \end{pmatrix} &= \begin{pmatrix} M_{11} & M_{12} \\ M_{21} & M_{22} \end{pmatrix} \begin{pmatrix} A_1 \\ B_1 \end{pmatrix} \\ &= \mathcal{C}^{-1} \begin{pmatrix} 0 & 1 \\ 1 & 0 \end{pmatrix}^{-1} \begin{pmatrix} M_{11} & M_{12} \\ M_{21} & M_{22} \end{pmatrix} \begin{pmatrix} 0 & 1 \\ 1 & 0 \end{pmatrix} \mathcal{C} \begin{pmatrix} A_1 \\ B_1 \end{pmatrix}, \end{aligned} \quad (4.281)$$

where \mathcal{C} denotes an operator that transforms a matrix to its complex conjugate, and thus

$$\mathcal{C}^{-1} \begin{pmatrix} 0 & 1 \\ 1 & 0 \end{pmatrix}^{-1} \begin{pmatrix} M_{11} & M_{12} \\ M_{21} & M_{22} \end{pmatrix} \begin{pmatrix} 0 & 1 \\ 1 & 0 \end{pmatrix} \mathcal{C} = \begin{pmatrix} M_{11} & M_{12} \\ M_{21} & M_{22} \end{pmatrix}, \quad (4.282)$$

or

$$\begin{pmatrix} M_{22}^* & M_{21}^* \\ M_{12}^* & M_{11}^* \end{pmatrix} = \begin{pmatrix} M_{11} & M_{12} \\ M_{21} & M_{22} \end{pmatrix}. \quad (4.283)$$

The above relation yields [see Eqs. (4.277) and (4.278)]

$$r' = -r^* \frac{t}{t^*}, \quad (4.284)$$

$$t' = \frac{1}{t^*} + \frac{rr'}{t} = \frac{1}{t^*} (1 - rr^*) = t. \quad (4.285)$$

and thus [see Eq. (4.278)]

$$\begin{pmatrix} M_{11} & M_{12} \\ M_{21} & M_{22} \end{pmatrix} = \begin{pmatrix} \frac{1}{t^*} & \frac{r}{t} \\ \frac{r^*}{t^*} & \frac{1}{t} \end{pmatrix}. \quad (4.286)$$

- c) For the case $V(x') = V(-x')$ if $\psi(x')$ is a solution then $\psi(-x')$ is a solution as well, and thus [see Eqs. (4.84), (4.86) and (4.87)]

$$r' = r . \quad (4.287)$$

The above relation (4.287) together with Eq. (4.284) yields

$$\text{Re}(rt^*) = 0 , \quad (4.288)$$

i.e. the reflection r and transmission t coefficients are complex numbers orthogonal to each other for this case.

30. In this problem the potential is piecewise constant. At the points where the piecewise constant potential abruptly changes the solution has to satisfy the requirements that both $\psi(x)$ and $d\psi/dx'$ [see Eq. (4.173)] are continuous. Consider first a general case, where a given potential is taken to be given by

$$V(x') = \begin{cases} U_1 & x' \leq x_0 \\ U_r & x' > x_0 \end{cases} , \quad (4.289)$$

where U_1 and U_r are constants, and the wavefunction is expressed as

$$\psi(x') = \begin{cases} A_1 e^{ik_1 x'} + B_1 e^{-ik_1 x'} & x' \leq x_0 \\ A_r e^{ik_r x'} + B_r e^{-ik_r x'} & x' > x_0 \end{cases} , \quad (4.290)$$

where A_1 , B_1 , A_r and B_r are constants, and where the constants k_1 and k_r is related to the energy of the particle E by [see Eq. (4.53)]

$$\frac{\hbar^2 k_1^2}{2m} = E - U_1 , \quad (4.291)$$

$$\frac{\hbar^2 k_r^2}{2m} = E - U_r . \quad (4.292)$$

The requirements that both $\psi(x)$ and $d\psi/dx'$ [see Eq. (4.173)] are continuous yield a linear relation between the amplitudes on the left A_1 and B_1 and those on the right A_r and B_r

$$\begin{pmatrix} A_1 \\ B_1 \end{pmatrix} = M \begin{pmatrix} A_r \\ B_r \end{pmatrix} , \quad (4.293)$$

where

$$\begin{aligned} M &= \begin{pmatrix} e^{ik_1 x_0} & e^{-ik_1 x_0} \\ k_1 e^{ik_1 x_0} & -k_1 e^{-ik_1 x_0} \end{pmatrix}^{-1} \begin{pmatrix} e^{ik_r x_0} & e^{-ik_r x_0} \\ k_r e^{ik_r x_0} & -k_r e^{-ik_r x_0} \end{pmatrix} \\ &= \frac{1}{2} \Phi(k_1 x_0) \begin{pmatrix} 1 + \frac{k_r}{k_1} & 1 - \frac{k_r}{k_1} \\ 1 - \frac{k_r}{k_1} & 1 + \frac{k_r}{k_1} \end{pmatrix} \Phi(-k_r x_0) , \end{aligned} \quad (4.294)$$

and where the matrix $\Phi(\theta)$ is defined by

$$\Phi(\theta) = \begin{pmatrix} e^{-i\theta} & 0 \\ 0 & e^{i\theta} \end{pmatrix}. \quad (4.295)$$

The above general result (4.293) is employed below for the given piecewise constant potential (4.88). Assume first that the wave function on the right side of the barrier in the region $x' > a/2$ is given by $\psi(x') = e^{ikx'}$, and on the left side of the barrier in the region $x' < -a/2$ it is given by $\psi(x') = Ae^{ikx'} + Be^{-ikx'}$. With the help of Eq. (4.293) one finds that

$$\begin{aligned} \begin{pmatrix} A \\ B \end{pmatrix} &= \frac{1}{4} \Phi\left(-\frac{ka}{2}\right) \begin{pmatrix} 1 + \frac{\kappa}{k} & 1 - \frac{\kappa}{k} \\ 1 - \frac{\kappa}{k} & 1 + \frac{\kappa}{k} \end{pmatrix} \Phi(\kappa a) \\ &\quad \times \begin{pmatrix} 1 + \frac{k}{\kappa} & 1 - \frac{k}{\kappa} \\ 1 - \frac{k}{\kappa} & 1 + \frac{k}{\kappa} \end{pmatrix} \Phi\left(-\frac{ka}{2}\right) \begin{pmatrix} 1 \\ 0 \end{pmatrix} \\ &= \begin{pmatrix} e^{ika} \left(\cos \kappa a - \frac{i}{2} \left(\frac{k}{\kappa} + \frac{\kappa}{k} \right) \sin \kappa a \right) \\ \frac{1}{2} i \left(\frac{\kappa}{k} - \frac{k}{\kappa} \right) \sin \kappa a \end{pmatrix}, \end{aligned} \quad (4.296)$$

where

$$\frac{\hbar^2 k^2}{2m} = E, \quad (4.297)$$

$$\frac{\hbar^2 \kappa^2}{2m} = E - U_b, \quad (4.298)$$

and thus

$$t = \frac{1}{A} = \frac{e^{-ika}}{\cos \kappa a - \frac{i}{2} \left(\frac{k}{\kappa} + \frac{\kappa}{k} \right) \sin \kappa a}, \quad (4.299)$$

$$r = \frac{B}{A} = \frac{\frac{1}{2} i \left(\frac{\kappa}{k} - \frac{k}{\kappa} \right) e^{-ika} \sin \kappa a}{\cos \kappa a - \frac{i}{2} \left(\frac{k}{\kappa} + \frac{\kappa}{k} \right) \sin \kappa a}. \quad (4.300)$$

Note that, as is expected from current conservation [see Eq. (4.276)], the following holds $|t|^2 + |r|^2 = 1$.

31. With the help of Eqs. (4.85) and (4.286) one finds that [see Eq. (4.84)]

$$\begin{pmatrix} \frac{1}{t_2^*} & \frac{r}{t} \\ \frac{r^*}{t_2^*} & \frac{1}{t} \end{pmatrix} = \Phi^{-1} \begin{pmatrix} \frac{1}{t_2^*} & \frac{r_2}{t_2} \\ \frac{r_2^*}{t_2^*} & \frac{1}{t_2} \end{pmatrix} \Phi \begin{pmatrix} \frac{1}{t_1^*} & \frac{r_1}{t_1} \\ \frac{r_1^*}{t_1^*} & \frac{1}{t_1} \end{pmatrix}, \quad (4.301)$$

where

$$\Phi = \begin{pmatrix} e^{ikl} & 0 \\ 0 & e^{-ikl} \end{pmatrix}, \quad (4.302)$$

thus

$$\begin{pmatrix} \frac{1}{t^*} & \frac{r}{t} \\ \frac{r^*}{t^*} & \frac{1}{t} \end{pmatrix} = \begin{pmatrix} \frac{1 + \frac{r_1^* r_2 t_2^* e^{-2ikl}}{t_2}}{t_1^* t_2^*} & \frac{r_1 + r_2 \frac{t_2^*}{t_2} e^{-2ikl}}{t_1^* t_2^*} \\ \frac{r_1^* + r_2^* \frac{t_2}{t_2^*} e^{2ikl}}{t_1^* t_2^*} & \frac{1 + \frac{r_1 r_2^* t_2 e^{2ikl}}{t_2^*}}{t_1 t_2} \end{pmatrix}, \quad (4.303)$$

hence

$$t = \frac{t_1 t_2}{1 + \frac{r_1 r_2^* t_2 e^{2ikl}}{t_2^*}}, \quad (4.304)$$

and [see Eq. (4.284)]

$$r' = -\frac{r^* t}{t^*} = -\frac{t_1 r_1^* + r_2^* \frac{t_2}{t_2^*} e^{2ikl}}{t_1^* \left(1 + \frac{r_1 r_2^* t_2 e^{2ikl}}{t_2^*}\right)}. \quad (4.305)$$

With the help of the relations $r_1' = -r_1^* t_1 / t_1^*$ and $r_2' = -r_2^* t_2 / t_2^*$ [see Eq. (4.284)] one finds that

$$t = \frac{t_1 t_2}{1 - r_1 r_2' e^{2ikl}}, \quad (4.306)$$

and (recall that $r_1 r_1^* + t_1 t_1^* = 1$)

$$\begin{aligned} r' &= r_1' + \frac{t_1^2 r_2' e^{2ikl}}{1 - r_1 r_2' e^{2ikl}} \\ &= \frac{r_1' \left(1 - \frac{r_2'}{r_1^*} e^{2ikl}\right)}{1 - r_1 r_2' e^{2ikl}}. \end{aligned} \quad (4.307)$$

Note that both transmission t (4.306) and reflection r' (4.307) coefficients can be expressed as an infinite sum over paths using the identity

$$\frac{1}{1 - r_1 r_2' e^{2ikl}} = \sum_{n=0}^{\infty} (r_1 r_2' e^{2ikl})^n. \quad (4.308)$$

A resonance occurs at any values of k , which is denoted by k_0 , for which the term $r_1 r_2' e^{2ik_0 l}$ obtains a real positive value. Consider the case where $|t_1| \ll 1$ and $|t_2| \ll 1$. For this case [note that $|r_n| = |r_n'| = \sqrt{1 - |t_n|^2} = 1 - |t_n|^2 / 2 + O(|t_n|^4)$]

$$\begin{aligned} 1 - r_1 r_2' e^{2ikl} &= 1 - |r_1 r_2'| e^{i\delta} \\ &\simeq \frac{|t_1|^2 + |t_2|^2}{2} - i\delta + O(\delta^2), \end{aligned} \quad (4.309)$$

and

$$\begin{aligned}
 1 - \frac{r'_2}{r_1^*} e^{2ikl} &= 1 - \left| \frac{r_2}{r_1} \right| - i \left| \frac{r_2}{r_1} \right| \delta + O(\delta^2) \\
 &\simeq \frac{|t_2|^2 - |t_1|^2}{2} - i\delta + O(\delta^2),
 \end{aligned} \tag{4.310}$$

where

$$\delta = 2(k - k_0)l, \tag{4.311}$$

and thus near a resonance the transmission t (4.306) and reflection r' (4.307) become

$$t = \frac{t_1 t_2}{T_+ - i\delta}, \tag{4.312}$$

and

$$r' = r'_1 \frac{T_- - i\delta}{T_+ - i\delta}, \tag{4.313}$$

where

$$T_{\pm} = \frac{|t_2|^2 \pm |t_1|^2}{2}. \tag{4.314}$$

32. The transmission t_N and reflection r_N coefficients of the array are found from [see Eqs. (4.301) and (4.302)]

$$\begin{pmatrix} \frac{1}{t_N^*} & \frac{r_N}{t_N} \\ \frac{r_N}{t_N^*} & \frac{1}{t_N} \end{pmatrix} = \begin{pmatrix} e^{-Nikl} & 0 \\ 0 & e^{Nikl} \end{pmatrix} Q^N, \tag{4.315}$$

where the matrix Q is given by

$$Q = \begin{pmatrix} e^{ikl} & 0 \\ 0 & e^{-ikl} \end{pmatrix} \begin{pmatrix} \frac{1}{t^*} & \frac{r}{t} \\ \frac{r}{t^*} & \frac{1}{t} \end{pmatrix}. \tag{4.316}$$

The eigenvalues λ_{\pm} of the matrix Q can be expressed as

$$\lambda_{\pm} = T/2 \pm \sqrt{(T/2)^2 - D}, \tag{4.317}$$

where T , which is given by

$$T = \frac{e^{ikl}}{t^*} + \frac{e^{-ikl}}{t}, \tag{4.318}$$

is the trace and where D , which is given by

$$D = \frac{1 - |r|^2}{|t|^2} = 1 ,$$

is the determinant of the matrix Q . In the limit of large N the array's transmission probability $|t_N|^2$ is close to unity when $|\lambda_{\pm}| = 1$. i.e. when $(T/2)^2 - D < 0$, or

$$-1 < \operatorname{Re} \frac{e^{-ikl}}{t} < 1 . \quad (4.319)$$

33. Using Eq. (4.45) one has

$$A(x, p) = \frac{1}{(2\pi\hbar)^2} \int \int \int \int p^{(c)} x^{(c)} e^{\frac{i}{\hbar} [\xi(x^{(c)} - x) + \eta(p^{(c)} - p)]} d\xi d\eta dx^{(c)} dp^{(c)} . \quad (4.320)$$

With the help of Eq. (2.184), which is given by

$$e^A e^B = e^{A+B} e^{(1/2)[A, B]} , \quad (4.321)$$

one has

$$e^{-\frac{i}{\hbar} \xi x} e^{-\frac{i}{\hbar} \eta p} = e^{-\frac{i}{\hbar} (\xi x + \eta p)} e^{-\frac{1}{2\hbar^2} \xi \eta [x, p]} , \quad (4.322)$$

thus

$$\begin{aligned} A(x, p) &= \frac{1}{(2\pi\hbar)^2} \int \int \int \int p^{(c)} x^{(c)} e^{\frac{i}{\hbar} (\xi x^{(c)} + \eta p^{(c)})} e^{\frac{i}{\hbar} \frac{\xi \eta}{2}} e^{-\frac{i}{\hbar} \xi x} e^{-\frac{i}{\hbar} \eta p} d\xi d\eta dx^{(c)} dp^{(c)} \\ &= \frac{1}{(2\pi\hbar)^2} \int \int \int \int p^{(c)} x^{(c)} e^{\frac{i}{\hbar} [(\xi(x^{(c)} + \frac{\eta}{2}) + \eta p^{(c)})]} e^{-\frac{i}{\hbar} \xi x} e^{-\frac{i}{\hbar} \eta p} d\xi d\eta dx^{(c)} dp^{(c)} . \end{aligned} \quad (4.323)$$

Changing the integration variable

$$x^{(c)} = x^{(c)'} - \frac{\eta}{2} , \quad (4.324)$$

one has

$$\begin{aligned} A(x, p) &= \frac{1}{(2\pi\hbar)^2} \int \int \int \int p^{(c)} \left(x^{(c)'} - \frac{\eta}{2} \right) e^{\frac{i}{\hbar} (\xi x^{(c)'} + \eta p^{(c)})} e^{-\frac{i}{\hbar} \xi x} e^{-\frac{i}{\hbar} \eta p} d\xi d\eta dx^{(c)'} dp^{(c)} \\ &= \frac{1}{(2\pi\hbar)^2} \int \int \int \int p^{(c)} \left(x^{(c)'} - \frac{\eta}{2} \right) e^{\frac{i}{\hbar} \xi (x^{(c)'} - x)} e^{\frac{i}{\hbar} \eta (p^{(c)} - p)} d\xi d\eta dx^{(c)'} dp^{(c)} . \end{aligned} \quad (4.325)$$

Using the identity

$$\int_{-\infty}^{\infty} dk e^{ik(x' - x'')} = 2\pi \delta(x' - x'') , \quad (4.326)$$

one finds that

$$\frac{1}{2\pi\hbar} \int e^{\frac{i}{\hbar}\xi(x^{(c)'}-x)} d\xi = \delta(x^{(c)'} - x) , \quad (4.327)$$

$$\frac{1}{2\pi\hbar} \int e^{\frac{i}{\hbar}\eta(p^{(c)}-p)} d\eta = \delta(p^{(c)} - p) , \quad (4.328)$$

thus

$$\begin{aligned} A(x,p) &= \frac{1}{2\pi\hbar} \int \int \int p^{(c)} \left(x^{(c)'} - \frac{\eta}{2}\right) e^{\frac{i}{\hbar}\eta(p^{(c)}-p)} d\eta dx^{(c)'} dp^{(c)} \frac{1}{2\pi\hbar} \int e^{\frac{i}{\hbar}\xi(x^{(c)'}-x)} d\xi \\ &= \frac{1}{2\pi\hbar} \int \int \int p^{(c)} \left(x^{(c)'} - \frac{\eta}{2}\right) e^{\frac{i}{\hbar}\eta(p^{(c)}-p)} d\eta dx^{(c)'} dp^{(c)} \delta(x^{(c)'} - x) \\ &= \frac{1}{2\pi\hbar} \int \int p^{(c)} \left(x - \frac{\eta}{2}\right) e^{\frac{i}{\hbar}\eta(p^{(c)}-p)} d\eta dp^{(c)} \\ &= \int p^{(c)} x dp^{(c)} \frac{1}{2\pi\hbar} \int e^{\frac{i}{\hbar}\eta(p^{(c)}-p)} d\eta - \frac{1}{2\pi\hbar} \int \int p^{(c)} \frac{\eta}{2} e^{\frac{i}{\hbar}\eta(p^{(c)}-p)} d\eta dp^{(c)} \\ &= px - \frac{1}{2\pi\hbar} \int \int p^{(c)} \frac{\eta}{2} e^{\frac{i}{\hbar}\eta(p^{(c)}-p)} d\eta dp^{(c)} \\ &= px - \frac{1}{2\pi\hbar} \frac{\hbar}{2i} \int \int p^{(c)} \frac{\partial e^{\frac{i}{\hbar}\eta(p^{(c)}-p)}}{\partial p^{(c)}} d\eta dp^{(c)} \\ &= px - \frac{\hbar}{2i} \int dp^{(c)} p^{(c)} \underbrace{\frac{\partial}{\partial p^{(c)}} \frac{1}{2\pi\hbar} \int d\eta e^{\frac{i}{\hbar}\eta(p^{(c)}-p)}}_{\delta(p^{(c)}-p)} . \end{aligned} \quad (4.329)$$

Integration by parts yields

$$\begin{aligned} A(x,p) &= px - \frac{\hbar}{2i} \int \left(\frac{\partial p^{(c)}}{\partial p^{(c)}}\right) \delta(p^{(c)} - p) dp^{(c)} \\ &= px - \frac{\hbar}{2i} \\ &= px + \frac{[x,p]}{2} \\ &= \frac{xp + px}{2} . \end{aligned} \quad (4.330)$$

34. Below we derive an expression for the variable $A(x^{(c)}, p^{(c)})$ in terms of the matrix elements of the operator $A(x, p)$ in the basis of position eigenvectors $|x'\rangle$. To that end we begin by evaluating the matrix element $\langle x' - \frac{x''}{2} | A(x, p) | x' + \frac{x''}{2} \rangle$ using Eqs. (4.323), (3.19) and (4.327)

$$\begin{aligned}
& \left\langle x' - \frac{x''}{2} \left| A(x, p) \right| x' + \frac{x''}{2} \right\rangle \\
&= \frac{1}{(2\pi\hbar)^2} \int \int \int \int A(x^{(c)}, p^{(c)}) e^{\frac{i}{\hbar}[(\xi(x^{(c)} + \frac{\eta}{2}) + \eta p^{(c)})]} \\
&\quad \times \left\langle x' - \frac{x''}{2} \left| e^{-\frac{i}{\hbar}\xi x} e^{-\frac{i}{\hbar}\eta p} \right| x' + \frac{x''}{2} \right\rangle d\xi d\eta dx^{(c)} dp^{(c)} \\
&= \frac{1}{(2\pi\hbar)^2} \int \int \int \int A(x^{(c)}, p^{(c)}) e^{\frac{i}{\hbar}[(\xi(x^{(c)} + \frac{\eta}{2}) + \eta p^{(c)})]} e^{-\frac{i}{\hbar}\xi(x' - \frac{x''}{2})} \\
&\quad \times \left\langle x' - \frac{x''}{2} \left| x' + \frac{x''}{2} + \eta \right\rangle d\xi d\eta dx^{(c)} dp^{(c)} \\
&= \frac{1}{(2\pi\hbar)^2} \int \int A(x^{(c)}, p^{(c)}) e^{-\frac{i}{\hbar}x''p^{(c)}} dx^{(c)} dp^{(c)} \int e^{\frac{i}{\hbar}[\xi(x^{(c)} - x')]} d\xi \\
&= \frac{1}{2\pi\hbar} \int \int A(x^{(c)}, p^{(c)}) e^{-\frac{i}{\hbar}x''p^{(c)}} dx^{(c)} dp^{(c)} \delta(x^{(c)} - x') \\
&= \frac{1}{2\pi\hbar} \int A(x', p^{(c)}) e^{-\frac{i}{\hbar}x''p^{(c)}} dp^{(c)} .
\end{aligned}$$

Applying the inverse Fourier transform, i.e. multiplying by $e^{\frac{i}{\hbar}x''p'}$ and integrating over x'' yields

$$\begin{aligned}
& \int \left\langle x' - \frac{x''}{2} \left| A(x, p) \right| x' + \frac{x''}{2} \right\rangle e^{\frac{i}{\hbar}x''p'} dx'' \\
&= \frac{1}{2\pi\hbar} \int A(x', p^{(c)}) dp^{(c)} \int e^{\frac{i}{\hbar}x''(p' - p^{(c)})} dx'' ,
\end{aligned} \tag{4.331}$$

thus with the help of Eq. (4.328) one finds the desired inversion of Eq. (4.45) is given by

$$A(x', p') = \int \left\langle x' - \frac{x''}{2} \left| A(x, p) \right| x' + \frac{x''}{2} \right\rangle e^{\frac{i}{\hbar}x''p'} dx'' . \tag{4.332}$$

Note that $A(x', p')$, which appears on the left hand side of the above equation (4.332) is a classical variable, whereas $A(x, p)$ on the right hand side is the corresponding quantum operator. A useful relations can be obtained by integrating $A(x', p')$ over p' . With the help of Eq. (4.327) one finds that

$$\begin{aligned}
\int A(x', p') dp' &= \int dx'' \left\langle x' - \frac{x''}{2} \left| A(x, p) \right| x' + \frac{x''}{2} \right\rangle \int e^{\frac{i}{\hbar}x''p'} dp' \\
&= 2\pi\hbar \langle x' | A(x, p) | x' \rangle .
\end{aligned} \tag{4.333}$$

Another useful relations can be obtained by integrating $A(x', p')$ over x' . With the help of Eqs. (3.52) and (4.328) one finds that

$$\begin{aligned}
 \int A(x', p') dx' &= \int \int \left\langle x' - \frac{x''}{2} \left| A(x, p) \right| x' + \frac{x''}{2} \right\rangle e^{\frac{i}{\hbar} x'' p'} dx'' dx' \\
 &= \int \int \int \int \left\langle x' - \frac{x''}{2} \left| p'' \right\rangle \langle p'' \left| A(x, p) \right| p'' \right\rangle \langle p'' \left| x' + \frac{x''}{2} \right\rangle e^{\frac{i}{\hbar} x'' p'} dx'' dx' dp'' dp''' \\
 &= \frac{1}{2\pi\hbar} \int \int \int \int e^{\frac{i}{\hbar} x' (p'' - p''')} e^{\frac{i}{\hbar} \frac{x''}{2} (-p'' - p''')} \langle p'' \left| A(x, p) \right| p'' \rangle e^{\frac{i}{\hbar} x'' p'} dx'' dx' dp'' dp''' \\
 &= \int \int \int \delta(p'' - p''') e^{\frac{i}{\hbar} \frac{x''}{2} (-p'' - p''')} \langle p'' \left| A(x, p) \right| p'' \rangle e^{\frac{i}{\hbar} x'' p'} dx'' dp'' dp''' \\
 &= \int \int \langle p'' \left| A(x, p) \right| p'' \rangle e^{\frac{i}{\hbar} x'' (p' - p'')} dx'' dp'' \\
 &= 2\pi\hbar \int \langle p'' \left| A(x, p) \right| p'' \rangle \delta(p' - p'') dp'' \\
 &= 2\pi\hbar \langle p' \left| A(x, p) \right| p' \rangle .
 \end{aligned} \tag{4.334}$$

35. By expressing $|\psi\rangle$ as

$$|\psi\rangle = |\psi_1\rangle + |\psi_2\rangle ,$$

where $|\psi_1\rangle = P|\psi\rangle$ and $|\psi_2\rangle = Q|\psi\rangle$ (recall that $1 = P + Q$), and by multiplying Eq. (4.90) from the left by P one obtains (recall that $P^2 = P$ and $Q^2 = Q$)

$$\mathcal{H}_{11} |\psi_1\rangle + \mathcal{H}_{12} |\psi_2\rangle = E |\psi_1\rangle . \tag{4.335}$$

Similarly, by multiplying Eq. (4.90) from the left by Q one obtains

$$\mathcal{H}_{21} |\psi_1\rangle + \mathcal{H}_{22} |\psi_2\rangle = E |\psi_2\rangle . \tag{4.336}$$

The last result (4.336) yields

$$|\psi_2\rangle = (E - \mathcal{H}_{22})^{-1} \mathcal{H}_{21} |\psi_1\rangle . \tag{4.337}$$

Substituting into Eq. (4.335) leads to

$$\left[\mathcal{H}_{11} + \mathcal{H}_{12} (E - \mathcal{H}_{22})^{-1} \mathcal{H}_{21} \right] |\psi_1\rangle = E |\psi_1\rangle , \tag{4.338}$$

in agreement with Eq. (4.91).

36. With the help of Eqs. (4.99), (4.100) and (4.101) one finds that

$$\begin{aligned}
 i\hbar \frac{dU_I}{dt} &= \frac{1}{N} (U^\dagger)^N \sum_{k=1}^N (Uu)^{N-k} (U\mathcal{H})(Uu)^{k-1} U^N \\
 &= \mathcal{H}_{\text{eff}} U_I ,
 \end{aligned} \tag{4.339}$$

where

$$\mathcal{H}_{\text{eff}} = \frac{1}{N} (U^\dagger)^N \sum_{k=1}^N (Uu)^{N-k} U \mathcal{H} (Uu)^{k-1} U^N U_1^\dagger. \quad (4.340)$$

In the limit $N \rightarrow \infty$ the effective Hamiltonian \mathcal{H}_{eff} becomes [in this limit $u \rightarrow \mathbf{1}$, see Eq. (4.100)]

$$\mathcal{H}_{\text{eff}} = \frac{1}{N} \sum_{k=1}^N (U^\dagger)^{k-1} \mathcal{H} U^{k-1}. \quad (4.341)$$

In a diagonal form the unitary operator can be expressed as [see Eq. (2.70)]

$$U = \sum_n P_n e^{i\theta_n}, \quad (4.342)$$

where P_n are projection operators, $e^{i\theta_n}$ are eigenvalues and θ_n are distinct real numbers. Using this notation Eq. (4.341) becomes

$$\mathcal{H}_{\text{eff}} = \sum_{n', n''} P_{n''} \mathcal{H} P_{n'} \frac{1}{N} \sum_{k=1}^N e^{i(\theta_{n'} - \theta_{n''})(k-1)}. \quad (4.343)$$

With the help of the identity

$$\frac{1}{N} \sum_{k=1}^N e^{i\theta(k-1)} = \begin{cases} \frac{e^{i\theta N} - 1}{N(e^{i\theta} - 1)} & \theta \neq 0 \\ 1 & \theta = 0 \end{cases}, \quad (4.344)$$

one finds that in the limit $N \rightarrow \infty$ the effective Hamiltonian \mathcal{H}_{eff} (4.343) becomes

$$\mathcal{H}_{\text{eff}} = \sum_{n'} P_{n'} \mathcal{H} P_{n'}. \quad (4.345)$$

37. The unitary transformation U to the basis $\{|e_x\rangle, |e_y\rangle, |\sigma_N\rangle, |\sigma_C\rangle\}$ is given by [see Eqs. (4.112), (4.113), (4.114) and (4.115)]

$$U = \begin{pmatrix} \frac{2}{\sqrt{6}} & 0 & 0 & \frac{1}{\sqrt{3}} \\ -\frac{1}{\sqrt{6}} & \frac{1}{\sqrt{2}} & 0 & \frac{1}{\sqrt{3}} \\ -\frac{1}{\sqrt{6}} & -\frac{1}{\sqrt{2}} & 0 & \frac{1}{\sqrt{3}} \\ 0 & 0 & 1 & 0 \end{pmatrix}. \quad (4.346)$$

- a) For example [see Eqs. (4.105) and (4.107)]

$$\begin{aligned}
 [U(C_3^+), \mathcal{H}] &\doteq \begin{pmatrix} \delta_c & \delta_c & \epsilon_c & \delta_n \\ \epsilon_c & \delta_c & \delta_c & \delta_n \\ \delta_c & \epsilon_c & \delta_c & \delta_n \\ \delta_n & \delta_n & \delta_n & \epsilon_n \end{pmatrix} - \begin{pmatrix} \delta_c & \delta_c & \epsilon_c & \delta_n \\ \epsilon_c & \delta_c & \delta_c & \delta_n \\ \delta_c & \epsilon_c & \delta_c & \delta_n \\ \delta_n & \delta_n & \delta_n & \epsilon_n \end{pmatrix} \\
 &= \begin{pmatrix} 0 & 0 & 0 & 0 \\ 0 & 0 & 0 & 0 \\ 0 & 0 & 0 & 0 \\ 0 & 0 & 0 & 0 \end{pmatrix}.
 \end{aligned} \tag{4.347}$$

The other relations $[\mathcal{U}, \mathcal{H}] = 0$ are checked in a similar way.

b) The results are given by the table below [see Eq. (4.346)].

	\mathcal{U}	$U^{-1}\mathcal{U}U$
E	$\begin{pmatrix} 1 & 0 & 0 & 0 \\ 0 & 1 & 0 & 0 \\ 0 & 0 & 1 & 0 \\ 0 & 0 & 0 & 1 \end{pmatrix}$	$\begin{pmatrix} 1 & 0 & 0 & 0 \\ 0 & 1 & 0 & 0 \\ 0 & 0 & 1 & 0 \\ 0 & 0 & 0 & 1 \end{pmatrix}$
C_3^+	$\begin{pmatrix} 0 & 0 & 1 & 0 \\ 1 & 0 & 0 & 0 \\ 0 & 1 & 0 & 0 \\ 0 & 0 & 0 & 1 \end{pmatrix}$	$\begin{pmatrix} -\frac{1}{2} & -\frac{\sqrt{3}}{2} & 0 & 0 \\ \frac{\sqrt{3}}{2} & -\frac{1}{2} & 0 & 0 \\ 0 & 0 & 1 & 0 \\ 0 & 0 & 0 & 1 \end{pmatrix}$
C_3^-	$\begin{pmatrix} 0 & 1 & 0 & 0 \\ 0 & 0 & 1 & 0 \\ 1 & 0 & 0 & 0 \\ 0 & 0 & 0 & 1 \end{pmatrix}$	$\begin{pmatrix} -\frac{1}{2} & \frac{\sqrt{3}}{2} & 0 & 0 \\ -\frac{\sqrt{3}}{2} & -\frac{1}{2} & 0 & 0 \\ 0 & 0 & 1 & 0 \\ 0 & 0 & 0 & 1 \end{pmatrix}$
R_1	$\begin{pmatrix} 1 & 0 & 0 & 0 \\ 0 & 0 & 1 & 0 \\ 0 & 1 & 0 & 0 \\ 0 & 0 & 0 & 1 \end{pmatrix}$	$\begin{pmatrix} 1 & 0 & 0 & 0 \\ 0 & -1 & 0 & 0 \\ 0 & 0 & 1 & 0 \\ 0 & 0 & 0 & 1 \end{pmatrix}$
R_2	$\begin{pmatrix} 0 & 0 & 1 & 0 \\ 0 & 1 & 0 & 0 \\ 1 & 0 & 0 & 0 \\ 0 & 0 & 0 & 1 \end{pmatrix}$	$\begin{pmatrix} -\frac{1}{2} & -\frac{\sqrt{3}}{2} & 0 & 0 \\ -\frac{\sqrt{3}}{2} & \frac{1}{2} & 0 & 0 \\ 0 & 0 & 1 & 0 \\ 0 & 0 & 0 & 1 \end{pmatrix}$
R_3	$\begin{pmatrix} 0 & 1 & 0 & 0 \\ 1 & 0 & 0 & 0 \\ 0 & 0 & 1 & 0 \\ 0 & 0 & 0 & 1 \end{pmatrix}$	$\begin{pmatrix} -\frac{1}{2} & \frac{\sqrt{3}}{2} & 0 & 0 \\ \frac{\sqrt{3}}{2} & \frac{1}{2} & 0 & 0 \\ 0 & 0 & 1 & 0 \\ 0 & 0 & 0 & 1 \end{pmatrix}$

Note that both $|\sigma_N\rangle$ and $|\sigma_C\rangle$ are eigenvectors of $U(E)$, $U(C_3^+)$, $U(C_3^-)$, $U(R_1)$, $U(R_2)$ and $U(R_3)$, with eigenvalue unity.

c) With the help of Eqs. (4.105) and (4.346) one finds that

$$U^{-1}\mathcal{H}U = \begin{pmatrix} \epsilon_c - \delta_c & 0 & 0 & 0 \\ 0 & \epsilon_c - \delta_c & 0 & 0 \\ 0 & 0 & \epsilon_n & \sqrt{3}\delta_n \\ 0 & 0 & \sqrt{3}\delta_n & \epsilon_c + 2\delta_c \end{pmatrix},$$

or

$$U^{-1}\mathcal{H}U \doteq \begin{pmatrix} \epsilon_c - \delta_c & 0 & 0 & 0 \\ 0 & \epsilon_c - \delta_c & 0 & 0 \\ 0 & 0 & \epsilon_a - \epsilon_s \cos \theta_a & \epsilon_s \sin \theta_a \\ 0 & 0 & \epsilon_s \sin \theta_a & \epsilon_a + \epsilon_s \cos \theta_a \end{pmatrix}, \quad (4.348)$$

where

$$\epsilon_a = \frac{\epsilon_n + \epsilon_c + 2\delta_c}{2}, \quad (4.349)$$

$$\epsilon_s = \frac{\sqrt{(\epsilon_n - (\epsilon_c + 2\delta_c))^2 + 12\delta_n^2}}{2}, \quad (4.350)$$

$$\tan \theta_a = \frac{-2\sqrt{3}\delta_n}{\epsilon_n - (\epsilon_c + 2\delta_c)}. \quad (4.351)$$

The energy eigenvalues corresponding to the subspace spanned by the states $|\sigma_N\rangle$ and $|\sigma_C\rangle$ are $\epsilon_a \pm \epsilon_s$. Due to the attractive nature of the electron-ion Coulomb interaction it is expected that $\epsilon_n < \epsilon_c < 0$ (nitrogen has 7 protons whereas carbon has only six). To first order in δ_c and δ_n one has $\epsilon_a - \epsilon_s = \epsilon_n$ and $\epsilon_a + \epsilon_s = \epsilon_c + 2\delta_c$ (vanishing first order in δ_n contribution). Thus the assumptions that $|\delta_c|, |\delta_n| \ll |\epsilon_n|, |\epsilon_c|$ and $\delta_c < 0$ implies that the ordering of energy eigenvalues from low to high is given by $\epsilon_a - \epsilon_s$, $\epsilon_a + \epsilon_s$ and $\epsilon_c - \delta_c$. In NV defect in diamond, the lowest energy $\epsilon_a - \epsilon_s$ lies inside the valence band.

5. The Harmonic Oscillator

Consider a particle of mass m in a parabolic potential well

$$U(x) = \frac{1}{2}m\omega^2 x^2 ,$$

where the angular frequency ω is a constant. The classical equation of motion for the coordinate x is given by [see Eq. (1.19)]

$$m\ddot{x} = -\frac{\partial U}{\partial x} = -m\omega^2 x . \quad (5.1)$$

It is convenient to introduce the complex variable α , which is given by

$$\alpha = \frac{1}{x_0} \left(x + \frac{i}{\omega} \dot{x} \right) , \quad (5.2)$$

where x_0 is a constant having dimension of length. Using Eq. (5.1) one finds that

$$\dot{\alpha} = \frac{1}{x_0} \left(\dot{x} + \frac{i}{\omega} \ddot{x} \right) = \frac{1}{x_0} \left(\dot{x} - \frac{i}{\omega} \omega^2 x \right) = -i\omega \alpha . \quad (5.3)$$

The solution is given by

$$\alpha = \alpha_0 e^{-i\omega t} , \quad (5.4)$$

where $\alpha_0 = \alpha(t=0)$. Thus, x and \dot{x} oscillate in time according to

$$x = x_0 \operatorname{Re} (\alpha_0 e^{-i\omega t}) , \quad (5.5)$$

$$\dot{x} = x_0 \omega \operatorname{Im} (\alpha_0 e^{-i\omega t}) . \quad (5.6)$$

The Hamiltonian is given by [see Eq. (1.34)]

$$\mathcal{H} = \frac{p^2}{2m} + \frac{m\omega^2 x^2}{2} . \quad (5.7)$$

In quantum mechanics the variables x and p are regarded as operators satisfying the following commutation relations [see Eq. (3.9)]

$$[x, p] = xp - px = i\hbar . \quad (5.8)$$

5.1 Eigenstates

The annihilation and creation operators are defined as

$$a = \sqrt{\frac{m\omega}{2\hbar}} \left(x + \frac{ip}{m\omega} \right), \quad (5.9)$$

$$a^\dagger = \sqrt{\frac{m\omega}{2\hbar}} \left(x - \frac{ip}{m\omega} \right). \quad (5.10)$$

The inverse transformation is given by

$$x = \sqrt{\frac{\hbar}{2m\omega}} (a + a^\dagger), \quad (5.11)$$

$$p = i\sqrt{\frac{m\hbar\omega}{2}} (-a + a^\dagger). \quad (5.12)$$

The following holds

$$[a, a^\dagger] = \frac{i}{2\hbar} ([p, x] - [x, p]) = 1, \quad (5.13)$$

The number operator, which is defined as

$$N = a^\dagger a, \quad (5.14)$$

can be expressed in terms of the Hamiltonian

$$\begin{aligned} N &= a^\dagger a \\ &= \frac{m\omega}{2\hbar} \left(x - \frac{ip}{m\omega} \right) \left(x + \frac{ip}{m\omega} \right) \\ &= \frac{m\omega}{2\hbar} \left(\frac{p^2}{m^2\omega^2} + x^2 + \frac{i[x, p]}{m\omega} \right) \\ &= \frac{1}{\hbar\omega} \left(\frac{p^2}{2m} + \frac{m\omega^2 x^2}{2} \right) - \frac{1}{2} \\ &= \frac{\mathcal{H}}{\hbar\omega} - \frac{1}{2}. \end{aligned} \quad (5.15)$$

Thus, the Hamiltonian can be written as

$$\mathcal{H} = \hbar\omega \left(N + \frac{1}{2} \right). \quad (5.16)$$

The operator N is Hermitian, i.e. $N = N^\dagger$, therefore its eigenvalues are expected to be real. Let $\{|n\rangle\}$ be the set of eigenvectors of N and let $\{n\}$ be the corresponding set of eigenvalues

$$N |n\rangle = n |n\rangle . \quad (5.17)$$

According to Eq. (5.16) the eigenvectors of N are also eigenvectors of \mathcal{H}

$$\mathcal{H} |n\rangle = E_n |n\rangle , \quad (5.18)$$

where the eigenenergies E_n are given by

$$E_n = \hbar\omega \left(n + \frac{1}{2} \right) . \quad (5.19)$$

Theorem 5.1.1. *Let $|n\rangle$ be a normalized eigenvector of the operator N with eigenvalue n . Then (i) the vector*

$$|n+1\rangle = (n+1)^{-1/2} a^\dagger |n\rangle \quad (5.20)$$

is a normalized eigenvector of the operator N with eigenvalue $n+1$; (ii) the vector

$$|n-1\rangle = n^{-1/2} a |n\rangle \quad (5.21)$$

is a normalized eigenvector of the operator N with eigenvalue $n-1$

Proof. Using the commutation relations

$$[N, a^\dagger] = a^\dagger [a, a^\dagger] = a^\dagger , \quad (5.22)$$

$$[N, a] = [a^\dagger, a] a = -a , \quad (5.23)$$

one finds that

$$N a^\dagger |n\rangle = ([N, a^\dagger] + a^\dagger N) |n\rangle = (n+1) a^\dagger |n\rangle , \quad (5.24)$$

and

$$N a |n\rangle = ([N, a] + a N) |n\rangle = (n-1) a |n\rangle . \quad (5.25)$$

Thus, the vector $a^\dagger |n\rangle$, which is proportional to $|n+1\rangle$, is an eigenvector of the operator N with eigenvalue $n+1$ and the vector $a |n\rangle$, which is proportional to $|n-1\rangle$, is an eigenvector of the operator N with eigenvalue $n-1$. Normalization is verified as follows

$$\langle n+1 | n+1 \rangle = (n+1)^{-1} \langle n | a a^\dagger |n\rangle = (n+1)^{-1} \langle n | [a, a^\dagger] + a^\dagger a |n\rangle = 1 , \quad (5.26)$$

and

$$\langle n-1 | n-1 \rangle = n^{-1} \langle n | a^\dagger a |n\rangle = 1 . \quad (5.27)$$

As we have seen from the above theorem the following hold

$$a|n\rangle = \sqrt{n}|n-1\rangle, \quad (5.28)$$

$$a^\dagger|n\rangle = \sqrt{n+1}|n+1\rangle. \quad (5.29)$$

Claim. The spectrum (i.e. the set of eigenvalues) of N are the nonnegative integers $\{0, 1, 2, \dots\}$.

Proof. First, note that since the operator N is positive-definite the eigenvalues are necessarily non negative

$$n = \langle n|a^\dagger a|n\rangle \geq 0. \quad (5.30)$$

On the other hand, according to Eq. (5.28), if n is an eigenvalue also $n-1$ is an eigenvalue, unless $n=0$. For the later case according to Eq. (5.28) $a|0\rangle = 0$. Therefore, n must be an integer, since otherwise one reaches a contradiction with the requirement that $n \geq 0$.

According to exercise 7 of set 4, in one-dimensional problems the energy spectrum of the bound states is always non-degenerate. Therefore, one concludes that all eigenvalues of N are non-degenerate. Therefore, the closure relation can be written as

$$1 = \sum_{n=0}^{\infty} |n\rangle \langle n|. \quad (5.31)$$

Furthermore, using Eq. (5.29) one can express the state $|n\rangle$ in terms of the ground state $|0\rangle$ as

$$|n\rangle = \frac{(a^\dagger)^n}{\sqrt{n!}}|0\rangle. \quad (5.32)$$

5.2 Coherent States

As can be easily seen from Eqs. (5.11), (5.12), (5.28) and (5.29), all energy eigenstates $|n\rangle$ have vanishing position and momentum expectation values

$$\langle n|x|n\rangle = 0, \quad (5.33)$$

$$\langle n|p|n\rangle = 0. \quad (5.34)$$

Clearly these states don't oscillate in phase space as classical harmonic oscillators do. Can one find quantum states having dynamics that resembles classical harmonic oscillators?

Definition 5.2.1. Consider a harmonic oscillator having ground state $|0\rangle$. A coherent state $|\alpha\rangle$ with a complex parameter α is defined by

$$|\alpha\rangle = D(\alpha) |0\rangle, \quad (5.35)$$

where

$$D(\alpha) = \exp(\alpha a^\dagger - \alpha^* a), \quad (5.36)$$

is the displacement operator.

In the set of problems at the end of this chapter the following results are obtained:

- The displacement operator is unitary $D^\dagger(\alpha) D(\alpha) = D(\alpha) D^\dagger(\alpha) = 1$.
- The coherent state $|\alpha\rangle$ is an eigenvector of the operator a with an eigenvalue α , namely

$$a |\alpha\rangle = \alpha |\alpha\rangle. \quad (5.37)$$

- For any function $f(a, a^\dagger)$ having a power series expansion the following holds

$$D^\dagger(\alpha) f(a, a^\dagger) D(\alpha) = f(a + \alpha, a^\dagger + \alpha^*). \quad (5.38)$$

- The displacement operator satisfies the following relations

$$D(\alpha) = e^{-\frac{|\alpha|^2}{2}} e^{\alpha a^\dagger} e^{-\alpha^* a} = e^{\frac{|\alpha|^2}{2}} e^{-\alpha^* a} e^{\alpha a^\dagger}, \quad (5.39)$$

$$D(\alpha) = e^{\sqrt{\frac{m\omega}{\hbar}} \frac{\alpha - \alpha^*}{\sqrt{2}} x} e^{-\frac{i}{\sqrt{m\hbar\omega}} \frac{\alpha + \alpha^*}{\sqrt{2}} p} e^{\frac{\alpha^2 - \alpha^{*2}}{4}}, \quad (5.40)$$

$$D(\alpha) D(\alpha') = \exp\left(\frac{\alpha\alpha'^* - \alpha^*\alpha'}{2}\right) D(\alpha + \alpha'). \quad (5.41)$$

- Coherent state expansion in the basis of number states

$$|\alpha\rangle = e^{-\frac{|\alpha|^2}{2}} \sum_{n=0}^{\infty} \frac{\alpha^n}{\sqrt{n!}} |n\rangle. \quad (5.42)$$

- The following expectation values hold

$$\langle \mathcal{H} \rangle_\alpha = \langle \alpha | \mathcal{H} | \alpha \rangle = \hbar\omega \left(|\alpha|^2 + 1/2 \right) , \quad (5.43)$$

$$\langle \alpha | \mathcal{H}^2 | \alpha \rangle = \hbar^2\omega^2 \left(|\alpha|^4 + 2|\alpha|^2 + 1/4 \right) , \quad (5.44)$$

$$\Delta \mathcal{H}_\alpha = \sqrt{\langle \alpha | (\Delta \mathcal{H})^2 | \alpha \rangle} = \hbar\omega |\alpha| , \quad (5.45)$$

$$\langle x \rangle_\alpha = \langle \alpha | x | \alpha \rangle = \sqrt{\frac{2\hbar}{m\omega}} \operatorname{Re}(\alpha) , \quad (5.46)$$

$$\langle p \rangle_\alpha = \langle \alpha | p | \alpha \rangle = \sqrt{2\hbar m\omega} \operatorname{Im}(\alpha) , \quad (5.47)$$

$$\Delta x_\alpha = \sqrt{\langle \alpha | (\Delta x)^2 | \alpha \rangle} = \sqrt{\frac{\hbar}{2m\omega}} , \quad (5.48)$$

$$\Delta p_\alpha = \sqrt{\langle \alpha | (\Delta p)^2 | \alpha \rangle} = \sqrt{\frac{\hbar m\omega}{2}} , \quad (5.49)$$

$$\Delta x_\alpha \Delta p_\alpha = \frac{\hbar}{2} . \quad (5.50)$$

- The wave function of a coherent state is given by

$$\begin{aligned} \psi_\alpha(x') &= \langle x' | \alpha \rangle \\ &= \exp\left(\frac{\alpha^{*2} - \alpha^2}{4}\right) \left(\frac{m\omega}{\pi\hbar}\right)^{1/4} \exp\left[-\left(\frac{x' - \langle x \rangle_\alpha}{2\Delta x_\alpha}\right)^2 + i \langle p \rangle_\alpha \frac{x'}{\hbar}\right] . \end{aligned} \quad (5.51)$$

- The following closure relation holds

$$1 = \frac{1}{\pi} \int \int |\alpha\rangle \langle \alpha| d^2\alpha , \quad (5.52)$$

where $d^2\alpha$ denotes infinitesimal area in the α complex plane, namely $d^2\alpha = d\{\operatorname{Re}\alpha\} d\{\operatorname{Im}\alpha\}$.

Given that at time $t = 0$ the oscillator is in a coherent state with parameter α_0 , namely $|\psi(t=0)\rangle = |\alpha_0\rangle$, the time evolution can be found with the help of Eqs. (4.14), (5.19) and (5.42)

$$\begin{aligned} |\psi(t)\rangle &= e^{-\frac{|\alpha_0|^2}{2}} \sum_{n=0}^{\infty} \exp\left(-\frac{iE_n t}{\hbar}\right) \frac{\alpha_0^n}{\sqrt{n!}} |n\rangle \\ &= e^{-i\omega t/2} e^{-\frac{|\alpha_0|^2}{2}} \sum_{n=0}^{\infty} \exp(-i\omega n t) \frac{\alpha_0^n}{\sqrt{n!}} |n\rangle \\ &= e^{-i\omega t/2} e^{-\frac{|\alpha_0|^2}{2}} \sum_{n=0}^{\infty} \frac{(\alpha_0 e^{-i\omega t})^n}{\sqrt{n!}} |n\rangle \\ &= e^{-i\omega t/2} |\alpha = \alpha_0 e^{-i\omega t}\rangle . \end{aligned} \quad (5.53)$$

In view of Eqs. (5.43), (5.45) (5.48) and (5.49), we see from this results that $\langle \mathcal{H} \rangle_\alpha$, $\Delta \mathcal{H}_\alpha$, Δx_α and Δp_α are all time independent. On the other hand, as can be seen from Eqs. (5.46) and (5.47) the following holds

$$\langle x \rangle_\alpha = \langle \alpha | x | \alpha \rangle = \sqrt{\frac{2\hbar}{m\omega}} \operatorname{Re} (\alpha_0 e^{-i\omega t}) , \quad (5.54)$$

$$\langle p \rangle_\alpha = \langle \alpha | p | \alpha \rangle = \sqrt{2\hbar m\omega} \operatorname{Im} (\alpha_0 e^{-i\omega t}) . \quad (5.55)$$

These results show that indeed, $\langle x \rangle_\alpha$ and $\langle p \rangle_\alpha$ have oscillatory time dependence identical to the dynamics of the position and momentum of a classical harmonic oscillator [compare with Eqs. (5.5) and (5.6)].

5.3 Problems

1. Calculate the wave functions $\psi_n(x') = \langle x' | n \rangle$ of the number states $|n\rangle$ of a harmonic oscillator.
2. Calculate the wavefunction in the momentum representation of the ground state of a harmonic oscillator.
3. Show that

$$\exp(2Xt - t^2) = \sum_{n=0}^{\infty} H_n(X) \frac{t^n}{n!} , \quad (5.56)$$

where $H_n(X)$ is the Hermite polynomial of order n , which is defined by

$$H_n(X) = \exp\left(\frac{X^2}{2}\right) \left(X - \frac{d}{dX}\right)^n \exp\left(-\frac{X^2}{2}\right) . \quad (5.57)$$

4. Show that

$$\sum_{n=0}^{\infty} \frac{\left(\frac{\alpha}{2}\right)^n H_n(X) H_n(Y)}{n!} = \frac{\exp\left(\frac{\alpha(2XY - \alpha X^2 - \alpha Y^2)}{1 - \alpha^2}\right)}{\sqrt{1 - \alpha^2}} , \quad (5.58)$$

where $H_n(X)$ is the Hermite polynomial of order n .

5. Show that for the state $|n\rangle$ of a harmonic oscillator

$$\langle (\Delta x)^2 \rangle \langle (\Delta p)^2 \rangle = \left(n + \frac{1}{2}\right)^2 \hbar^2 . \quad (5.59)$$

6. Consider a free particle in one dimension having mass m . Express the Heisenberg operator $x^{(H)}(t)$ in terms $x^{(H)}(0)$ and $p^{(H)}(0)$. At time $t = 0$ the system is in the state $|\psi_0\rangle$. Express the variance $\langle (\Delta x)^2 \rangle(t)$ at time t , where $\Delta x = x - \langle x \rangle$, in terms of the following expectation values at time $t = 0$

$$x_0 = \langle \psi_0 | x | \psi_0 \rangle , \quad (5.60)$$

$$p_0 = \langle \psi_0 | p | \psi_0 \rangle , \quad (5.61)$$

$$(xp)_0 = \langle \psi_0 | xp | \psi_0 \rangle , \quad (5.62)$$

$$(\Delta x)_0^2 = \langle \psi_0 | (x - x_0)^2 | \psi_0 \rangle , \quad (5.63)$$

$$(\Delta p)_0^2 = \langle \psi_0 | (p - p_0)^2 | \psi_0 \rangle . \quad (5.64)$$

7. Consider the normalized Gaussian wavefunction $\psi(x')$ given by

$$\psi(x') = \frac{1}{\pi^{1/4} x_0^{1/2}} \exp\left(-\frac{1}{2} \left(\frac{x'}{x_0}\right)^2\right) . \quad (5.65)$$

where x_0 is real. For what value of x_0 the energy expectation value $\langle \mathcal{H} \rangle$ is minimized, where \mathcal{H} , which is given by

$$\mathcal{H} = \frac{p^2}{2m} + \frac{m\omega^2 x^2}{2} , \quad (5.66)$$

is the Hamiltonian of a harmonic oscillator.

8. Consider a harmonic oscillator of angular frequency ω and mass m . Calculate the sum S_n , which is defined by

$$S_n = \sum_{n'=0}^{\infty} (E_{n'} - E_n) |\langle n' | x | n \rangle|^2 , \quad (5.67)$$

where $|n\rangle$ denotes the harmonic oscillator energy eigenvector having energy eigenvalue $E_n = \hbar\omega(n + 1/2)$, and x is the position operator.

9. Consider a harmonic oscillator of angular frequency ω and mass m .
- Express the Heisenberg picture $x^{(H)}(t)$ and $p^{(H)}(t)$ in terms $x^{(H)}(0)$ and $p^{(H)}(0)$.
 - Calculate the following commutators $[p^{(H)}(t_1), x^{(H)}(t_2)]$, $[p^{(H)}(t_1), p^{(H)}(t_2)]$ and $[x^{(H)}(t_1), x^{(H)}(t_2)]$.
10. Consider a particle having mass m confined by a one-dimensional potential $V(x)$, which is given by

$$V(x) = \begin{cases} \frac{m\omega^2}{2} x^2 & x > 0 \\ \infty & x \leq 0 \end{cases} , \quad (5.68)$$

where ω is a constant.

- Calculate the eigenenergies of the system.
 - Calculate the expectation values $\langle x^2 \rangle$ of all energy eigenstates of the particle.
11. Calculate the possible energy values of a particle in the potential given by

$$V(x) = \frac{m\omega^2}{2} x^2 + \alpha x . \quad (5.69)$$

12. Consider a particle having mass m and time dependent Hamiltonian given by

$$\mathcal{H} = \frac{p^2}{2m} + \frac{m\omega^2 x^2}{2}, \quad (5.70)$$

where the time dependent angular frequency ω is given by

$$\omega^2(t) = \omega_0^2 - \omega_p \delta(t), \quad (5.71)$$

and where ω_0 and ω_p are both positive constants. The state of the system at time t is denoted by $|\psi(t)\rangle$. Find a relation between the state just before the pulse $|\psi(0^-)\rangle$ at time $t = 0$ and the state just after the pulse $|\psi(0^+)\rangle$, where

$$|\psi(0^\pm)\rangle = \lim_{0 < t \rightarrow 0} |\psi(\pm t)\rangle. \quad (5.72)$$

13. A particle is in the ground state of harmonic oscillator with potential energy

$$V(x) = \frac{m\omega^2}{2} x^2. \quad (5.73)$$

Find the probability p to find the particle in the classically forbidden region.

14. Consider a particle having mass m in a potential V given by

$$V(x, y, z) = \begin{cases} \frac{m\omega^2 z^2}{2} - \frac{a}{2} \leq x \leq \frac{a}{2} & \text{and } -\frac{a}{2} \leq y \leq \frac{a}{2} \\ \infty & \text{else} \end{cases}, \quad (5.74)$$

where ω and a are positive real constants. Find the eigenenergies of the system.

15. Consider a harmonic oscillator having angular resonance frequency ω_0 . At time $t = 0$ the system's state is given by

$$|\alpha(t=0)\rangle = \frac{1}{\sqrt{2}} (|0\rangle + |1\rangle), \quad (5.75)$$

where the states $|0\rangle$ and $|1\rangle$ are the ground and first excited states, respectively, of the oscillator. Calculate as a function of time t the following quantities:

- a) $\langle x \rangle$
- b) $\langle p \rangle$
- c) $\langle x^2 \rangle$
- d) $\Delta x \Delta p$

16. Harmonic oscillator having angular resonance frequency ω is in state

$$|\psi(t=0)\rangle = \frac{1}{\sqrt{2}}(|0\rangle + |n\rangle) \quad (5.76)$$

at time $t = 0$, where $|0\rangle$ is the ground state and $|n\rangle$ is the eigenstate with eigenenergy $\hbar\omega(n + 1/2)$ (n is a non zero integer). Calculate the expectation value $\langle x \rangle$ for time $t \geq 0$.

17. Consider a harmonic oscillator having mass m and angular resonance frequency ω . At time $t = 0$ the system's state is given by $|\psi(0)\rangle = c_0|0\rangle + c_1|1\rangle$, where $|n\rangle$ are the eigenstates with energies $E_n = \hbar\omega(n + 1/2)$. Given that $\langle \mathcal{H} \rangle = \hbar\omega$, $|\psi(0)\rangle$ is normalized, and $\langle x \rangle(t=0) = \frac{1}{2}\sqrt{\frac{\hbar}{m\omega}}$, calculate $\langle x \rangle(t)$ at times $t > 0$.
18. Show that

$$D(\alpha) = e^{-\frac{|\alpha|^2}{2}} e^{\alpha a^\dagger} e^{-\alpha^* a} = e^{\frac{|\alpha|^2}{2}} e^{-\alpha^* a} e^{\alpha a^\dagger} . \quad (5.77)$$

19. Show that the displacement operator $D(\alpha)$ is unitary.
 20. Show that

$$|\alpha\rangle = e^{-\frac{|\alpha|^2}{2}} \sum_{n=0}^{\infty} \frac{\alpha^n}{\sqrt{n!}} |n\rangle . \quad (5.78)$$

21. Show that the coherent state $|\alpha\rangle$ is an eigenvector of the operator a with an eigenvalue α , namely

$$a|\alpha\rangle = \alpha|\alpha\rangle . \quad (5.79)$$

22. Show that

$$D(\alpha) = \exp\left(\sqrt{\frac{m\omega}{\hbar}} \frac{\alpha - \alpha^*}{\sqrt{2}} x\right) \times \exp\left(-\frac{i}{\sqrt{m\hbar\omega}} \frac{\alpha + \alpha^*}{\sqrt{2}} p\right) \exp\left(\frac{\alpha^{*2} - \alpha^2}{4}\right) . \quad (5.80)$$

23. Show that for any function $f(a, a^\dagger)$ having a power series expansion the following holds

$$D^\dagger(\alpha) f(a, a^\dagger) D(\alpha) = f(a + \alpha, a^\dagger + \alpha^*) . \quad (5.81)$$

24. Show that the following holds for a coherent state $|\alpha\rangle$:

- a) $\langle \alpha | \mathcal{H} | \alpha \rangle = \hbar\omega \left(|\alpha|^2 + 1/2 \right)$.
- b) $\langle \alpha | \mathcal{H}^2 | \alpha \rangle = \hbar^2 \omega^2 \left(|\alpha|^4 + 2|\alpha|^2 + 1/4 \right)$.
- c) $\sqrt{\langle \alpha | (\Delta \mathcal{H})^2 | \alpha \rangle} = \hbar\omega |\alpha|$.

- d) $\langle x \rangle_\alpha = \langle \alpha | x | \alpha \rangle = \sqrt{\frac{2\hbar}{m\omega}} \operatorname{Re}(\alpha)$.
 e) $\langle p \rangle_\alpha = \langle \alpha | p | \alpha \rangle = \sqrt{2\hbar m\omega} \operatorname{Im}(\alpha)$.
 f) $\Delta x_\alpha = \sqrt{\langle \alpha | (\Delta x)^2 | \alpha \rangle} = \sqrt{\frac{\hbar}{2m\omega}}$.
 g) $\Delta p_\alpha = \sqrt{\langle \alpha | (\Delta p)^2 | \alpha \rangle} = \sqrt{\frac{\hbar m\omega}{2}}$.
25. Consider a harmonic oscillator of mass m and angular resonance frequency ω . The Hamiltonian is given by

$$\mathcal{H} = \frac{p^2}{2m} + \frac{1}{2}m\omega^2 x^2. \quad (5.82)$$

The system at time t is in a normalized state $|\alpha\rangle$, which is an eigenvector of the annihilation operator a , thus

$$a|\alpha\rangle = \alpha|\alpha\rangle, \quad (5.83)$$

where the eigenvalue α is a complex number. At time $t > 0$ the energy of the system is measured. What are the possible results E_n and what are the corresponding probabilities $p_n(t)$?

26. Show that the wave function of a coherent state is given by

$$\begin{aligned} \psi_\alpha(x') &= \langle x' | \alpha \rangle \\ &= \exp\left(\frac{\alpha^{*2} - \alpha^2}{4}\right) \left(\frac{m\omega}{\pi\hbar}\right)^{1/4} \exp\left[-\left(\frac{x - \langle x \rangle_\alpha}{2\Delta x_\alpha}\right)^2 + i\langle p \rangle_\alpha \frac{x}{\hbar}\right]. \end{aligned} \quad (5.84)$$

27. Show that

$$D(\alpha)D(\alpha') = \exp\left(\frac{\alpha\alpha'^* - \alpha^*\alpha'}{2}\right) D(\alpha + \alpha'). \quad (5.85)$$

28. Show that the following closure relation holds

$$1 = \frac{1}{\pi} \int \int |\alpha\rangle \langle \alpha| d^2\alpha, \quad (5.86)$$

where $d^2\alpha$ denotes infinitesimal area in the α complex plane, namely $d^2\alpha = d\{\operatorname{Re}\alpha\}d\{\operatorname{Im}\alpha\}$.

29. Calculate the inner product between two coherent states $|\alpha\rangle$ and $|\beta\rangle$, where $\alpha, \beta \in \mathcal{C}$.
 30. For a given operator A show that

$$\operatorname{Tr} A = \frac{1}{\pi} \int d^2\alpha' \langle \alpha' | A | \alpha' \rangle, \quad (5.87)$$

where $|\alpha\rangle$ is a coherent state, and $d^2\alpha$ denotes infinitesimal area in the α complex plane, i.e. $d^2\alpha = d\{\operatorname{Re}\alpha\}d\{\operatorname{Im}\alpha\}$.

31. Show that

$$\text{Tr} [D(\alpha') D(\alpha'')] = \pi \delta(\alpha' + \alpha'') . \quad (5.88)$$

where $D(\alpha) = \exp(\alpha a^\dagger - \alpha^* a)$ is the displacement operator (5.36).

32. A one-dimensional potential acting on a particle having mass m is given by

$$V_1(x) = \frac{1}{2} m \omega^2 x^2 + \beta m \omega^2 x . \quad (5.89)$$

- a) Calculate the Heisenberg representation of the position operator $x^{(H)}(t)$ and its canonically conjugate operator $p^{(H)}(t)$.
- b) Given that the particle at time $t = 0$ is in the state $|0\rangle$, where the state $|0\rangle$ is the ground state of the potential

$$V_1(x) = \frac{1}{2} m \omega^2 x^2 . \quad (5.90)$$

Calculate the expectation value $\langle x \rangle$ at later times $t > 0$.

33. A particle having mass m is in the ground state of the one-dimensional potential well $V_1(x) = (1/2) m \omega^2 (x - \Delta_x)^2$ for times $t < 0$. At time $t = 0$ the potential suddenly changes and becomes $V_2(x) = (1/2) m \omega^2 x^2$.

- a) Calculate the expectation value $\langle x \rangle$ at times $t > 0$.
- b) Calculate the variance $\langle (\Delta x)^2 \rangle$ at times $t > 0$, where $\Delta x = x - \langle x \rangle$.
- c) The energy of the particle is measured at time $t > 0$. What are the possible results and what are the probabilities to obtain any of these results.

34. Consider a particle having mass m in the ground state of the potential well $V_a(x) = (1/2) m \omega^2 x^2$ for times $t < 0$. At time $t = 0$ the potential suddenly changes and becomes $V_b(x) = gx$. (a) Calculate the expectation value $\langle x \rangle$ at times $t > 0$. (b) Calculate the variance $\langle (\Delta x)^2 \rangle$ at times $t > 0$, where $\Delta x = x - \langle x \rangle$.

35. Consider a particle of mass m in a potential of a harmonic oscillator having angular frequency ω . The operator $S(r)$ is defined as

$$S(r) = \exp \left[\frac{r}{2} \left((a^\dagger)^2 - a^2 \right) \right] , \quad (5.91)$$

where r is a real number, and a and a^\dagger are the annihilation and creation operators respectively. The operator T is defined as

$$T = S(r) a S^\dagger(r) . \quad (5.92)$$

- a) Find an expression for the operator T of the form $T = Aa + Ba^\dagger$, where both A and B are constants.

b) The vector state $|r\rangle$ is defined as

$$|r\rangle = S^\dagger(r) |0\rangle, \quad (5.93)$$

where $|0\rangle$ is the ground state of the harmonic oscillator. Calculate the expectation values $\langle r|x|r\rangle$ of the operator x (displacement) and the expectation value $\langle r|p|r\rangle$ of the operator p (momentum).

c) Calculate the variance $(\Delta x)^2$ of x and the variance $(\Delta p)^2$ of p .

36. The normalized second-order correlation function $g^{(2)}$ with respect to a state $|\psi\rangle$ is defined by

$$g^{(2)} = \frac{\langle \psi | a^\dagger a^\dagger a a | \psi \rangle}{\langle \psi | a^\dagger a | \psi \rangle^2}. \quad (5.94)$$

where a and a^\dagger are the harmonic oscillator annihilation and creation operators respectively. Calculate $g^{(2)}$ for the case where the state $|\psi\rangle$ is given by

$$|\psi\rangle = S^\dagger(r) |0\rangle, \quad (5.95)$$

where the operator $S(r)$ is given by Eq. (5.91) and where r is a real number.

37. The state $|r\rangle$ from the previous exercise, which is called a squeezed state, can be alternatively defined as a normalized state that satisfies the relation

$$Q(r) |r\rangle = 0, \quad (5.96)$$

where the operator $Q(r)$ is defined by

$$Q(r) = a \cosh r + a^\dagger \sinh r, \quad (5.97)$$

r is a real number, and a and a^\dagger are the annihilation and creation operators respectively. Based on the above definition calculate the expectation values $\langle r|x|r\rangle$ of the position operator x , the expectation value $\langle r|p|r\rangle$ of the momentum operator p , the variance $(\Delta x)^2$ of x and the variance $(\Delta p)^2$ of p with respect to the state $|r\rangle$.

38. Consider one-dimensional motion of a particle having mass m . The Hamiltonian is given by

$$\mathcal{H} = \hbar\omega_0 a^\dagger a + \hbar\omega_1 a^\dagger a^\dagger a a, \quad (5.98)$$

where

$$a = \sqrt{\frac{m\omega_0}{2\hbar}} \left(x + \frac{ip}{m\omega_0} \right), \quad (5.99)$$

is the annihilation operator, x is the coordinate and p is its canonical conjugate momentum. The frequencies ω_0 and ω_1 are both positive.

- a) Calculate the eigenenergies of the system.
 b) Let $|0\rangle$ be the ground state of the system. Calculate
- i. $\langle 0|x|0\rangle$
 - ii. $\langle 0|p|0\rangle$
 - iii. $\langle 0|(\Delta x)^2|0\rangle$
 - iv. $\langle 0|(\Delta p)^2|0\rangle$
39. The Hamiltonian of a system is given by

$$\mathcal{H} = \epsilon N , \quad (5.100)$$

where the real non-negative parameter ϵ has units of energy, and where the operator N is given by

$$N = b^\dagger b . \quad (5.101)$$

The following holds

$$b^\dagger b + b b^\dagger = 1 , \quad (5.102)$$

$$b^2 = 0 , \quad (5.103)$$

$$(b^\dagger)^2 = 0 . \quad (5.104)$$

- a) Find the eigenvalues of \mathcal{H} . Clue: show first that $N^2 = N$.
 b) Let $|0\rangle$ be the ground state of the system, which is assumed to be non-degenerate. Define the two states
- $$|+\rangle = A_+ (1 + b^\dagger) |0\rangle , \quad (5.105a)$$
- $$|-\rangle = A_- (1 - b^\dagger) |0\rangle , \quad (5.105b)$$
- where the real non-negative numbers A_+ and A_- are normalization constants. Calculate A_+ and A_- . Clue: show first that $b^\dagger |0\rangle$ is an eigenvector of N .
 c) At time $t = 0$ the system is in the state

$$|\alpha(t=0)\rangle = |+\rangle , \quad (5.106)$$

Calculate the probability $p(t)$ to find the system in the state $|-\rangle$ at time $t > 0$.

40. **Normal ordering** - Let $f(a, a^\dagger)$ be a function of the annihilation a and creation a^\dagger operators. The normal ordering of $f(a, a^\dagger)$, which is denoted by $:f(a, a^\dagger):$ places the a operators on the right and the a^\dagger operators on the left. Some examples are given below

$$:aa^\dagger: = a^\dagger a , \quad (5.107)$$

$$:a^\dagger a: = a^\dagger a , \quad (5.108)$$

$$:(a^\dagger a)^n: = (a^\dagger)^n a^n . \quad (5.109)$$

Normal ordering is linear, i.e. $: f + g := : f : + : g :$. Show that the projection operator $P_n = |n\rangle \langle n|$, where $|n\rangle$ is an eigenvector of the Hamiltonian of a harmonic oscillator, can be expressed as

$$P_n = \frac{1}{n!} : (a^\dagger)^n \exp(-a^\dagger a) a^n : . \quad (5.110)$$

41. Consider a harmonic oscillator of angular frequency ω and mass m . A time dependent force is applied $f(t)$. The function $f(t)$ is assumed to vanish $f(t) \rightarrow 0$ in the limit $t \rightarrow \pm\infty$. Given that the oscillator was initially in its ground state $|0\rangle$ at $t \rightarrow -\infty$ calculate the probability p_n to find the oscillator in the number state $|n\rangle$ in the limit $t \rightarrow \infty$.
42. The parity operator \mathcal{P} is defined by

$$\mathcal{P} = \int_{-\infty}^{\infty} dx' |x'\rangle \langle -x'| , \quad (5.111)$$

where $|x'\rangle$ is an eigenvector of the position operator x having eigenvalue x' , i.e. $x|x'\rangle = x'|x'\rangle$. Express the parity operator \mathcal{P} as a function of the number operator $N = a^\dagger a$.

43. Show that

$$e^{\lambda a^\dagger a} = : \exp[(e^\lambda - 1) a^\dagger a] : . \quad (5.112)$$

44. Consider a harmonic oscillator having mass m and angular resonance frequency ω . Show that

$$|x'\rangle = \frac{\exp\left(-\frac{x'^2}{2x_0^2} + \sqrt{2}\frac{x'}{x_0}a^\dagger - \frac{a^{\dagger 2}}{2}\right)}{\pi^{1/4}x_0^{1/2}} |0\rangle , \quad (5.113)$$

where $|x'\rangle$ is an eigenvector of the position operator x with eigenvalue x' , i.e. $x|x'\rangle = x'|x'\rangle$,

$$a = \sqrt{\frac{m\omega}{2\hbar}} \left(x + \frac{ip}{m\omega} \right) \quad (5.114)$$

is the annihilation operator, $|0\rangle$ is the ground state and

$$x_0 = \sqrt{\frac{\hbar}{m\omega}} . \quad (5.115)$$

45. Show that

$$\frac{1}{\sqrt{1+\kappa}} \exp\left(\frac{\kappa}{1+\kappa} \frac{x^2}{x_0^2}\right) = : \exp\left(\kappa \frac{x^2}{x_0^2}\right) : , \quad (5.116)$$

where x is the position operator, κ is real and

$$x_0 = \sqrt{\frac{\hbar}{m\omega}} . \quad (5.117)$$

46. Let $F(X)$ be a smooth function of the normalized position operator X

$$X = \frac{a + a^\dagger}{\sqrt{2}} = \frac{x}{x_0}, \quad (5.118)$$

where a is the annihilation operator, x is the position operator and

$$x_0 = \sqrt{\frac{\hbar}{m\omega}}. \quad (5.119)$$

Show that

$$\frac{d}{dX} : F(X) : =: \frac{dF}{dX} : . \quad (5.120)$$

47. Calculate the matrix elements $\langle n_2 | S | n_1 \rangle$, where the operator S is given by

$$S = \sum_{k=0}^{\infty} \frac{(e^\lambda - 1)^k}{k!} a^{\dagger k} a^k, \quad (5.121)$$

where a is the harmonic oscillator annihilation operator, $|n_1\rangle$ and $|n_2\rangle$ are energy eigenstates and λ is real.

48. Consider a system having Hamiltonian \mathcal{H} given by

$$\mathcal{H} = \hbar\omega a^\dagger a + \hbar\omega_1 (a^\dagger a)^k, \quad (5.122)$$

where a and a^\dagger are the annihilation and creation operators, both ω and ω_1 are positive, and where k is integer. At initial time $t = 0$ the state of the system is an eigenstate of the operator a with eigenvalue α , i.e. $|\psi(t=0)\rangle = |\alpha\rangle_c$, where $a|\alpha\rangle_c = \alpha|\alpha\rangle_c$.

- Find a general expression for the state of the system $|\psi(t)\rangle$ at time $t > 0$.
 - Evaluate $|\psi(t)\rangle$ at time $t = 2\pi/\omega_1$.
 - Evaluate $|\psi(t)\rangle$ at time $t = \pi/\omega_1$.
 - Evaluate $|\psi(t)\rangle$ at time $t = \pi/2\omega_1$ for the case where k is even.
49. Consider two normalized coherent states $|\alpha\rangle$ and $|\beta\rangle$, where $\alpha, \beta \in \mathcal{C}$. The operator A is defined as

$$A = |\alpha\rangle \langle \alpha| - |\beta\rangle \langle \beta|. \quad (5.123)$$

Find the eigenvalues of the operator A .

5.4 Solutions

- The Hamiltonian is given by

$$\mathcal{H} = \frac{p^2}{2m} + \frac{m\omega^2 x^2}{2}.$$

Using Eqs. (3.21), (3.29), (5.9) and (5.10) one has

$$\langle x' | a | n \rangle = (2x_0^2)^{-1/2} \left(x' \psi_n(x') + x_0^2 \frac{d\psi_n}{dx'} \right), \quad (5.124)$$

$$\langle x' | a^\dagger | n \rangle = (2x_0^2)^{-1/2} \left(x' \psi_n(x') - x_0^2 \frac{d\psi_n}{dx'} \right), \quad (5.125)$$

where

$$x_0 = \sqrt{\frac{\hbar}{m\omega}}. \quad (5.126)$$

For the ground state $|0\rangle$, according to Eq. (5.28), $a|0\rangle = 0$, thus

$$x' \psi_0(x') + x_0^2 \frac{d\psi_0}{dx'} = 0. \quad (5.127)$$

The solution is given by

$$\psi_0(x') = A_0 \exp\left(-\frac{1}{2} \left(\frac{x'}{x_0}\right)^2\right), \quad (5.128)$$

where the normalization constant A_0 is found from the requirement

$$\int_{-\infty}^{\infty} |\psi_0(x')|^2 dx = 1, \quad (5.129)$$

thus

$$|A_0|^2 \underbrace{\int_{-\infty}^{\infty} \exp\left(-\left(\frac{x'}{x_0}\right)^2\right) dx}_{\sqrt{\pi}x_0} = 1. \quad (5.130)$$

Choosing A_0 to be real leads to

$$\psi_0(x') = \frac{1}{\pi^{1/4} x_0^{1/2}} \exp\left(-\frac{1}{2} \left(\frac{x'}{x_0}\right)^2\right). \quad (5.131)$$

All other wavefunctions are found using Eqs. (5.32) and (5.125)

$$\begin{aligned} \psi_n(x') &= \frac{1}{(2x_0)^{n/2} \sqrt{n!}} \left(x' - x_0^2 \frac{d}{dx'} \right)^n \psi_0(x') \\ &= \frac{1}{\pi^{1/4} \sqrt{2^n n!}} \frac{1}{x_0^{n+1/2}} \left(x' - x_0^2 \frac{d}{dx'} \right)^n \exp\left(-\frac{1}{2} \left(\frac{x'}{x_0}\right)^2\right). \end{aligned} \quad (5.132)$$

Using the notation

$$H_n(X) = \exp\left(\frac{X^2}{2}\right) \left(X - \frac{d}{dX}\right)^n \exp\left(-\frac{X^2}{2}\right), \quad (5.133)$$

the expression for $\psi_n(x')$ can be rewritten as

$$\psi_n(x') = \frac{\exp\left(-\frac{x'^2}{2x_0^2}\right) H_n\left(\frac{x'}{x_0}\right)}{\pi^{1/4} x_0^{1/2} \sqrt{2^n n!}}. \quad (5.134)$$

The term $H_n(X)$, which is called the Hermite polynomial of order n , is calculated below for some low values of n

$$H_0(X) = 1, \quad (5.135)$$

$$H_1(X) = 2X, \quad (5.136)$$

$$H_2(X) = 4X^2 - 2, \quad (5.137)$$

$$H_3(X) = 8X^3 - 12X, \quad (5.138)$$

$$H_4(X) = 16X^4 - 48X^2 + 12. \quad (5.139)$$

2. With the help of Eqs. (3.60) and (5.131) one finds that

$$\begin{aligned} \phi_0(p') &= \frac{\int_{-\infty}^{\infty} dx' e^{-\frac{ip'x'}{\hbar}} \psi_0(x')}{\sqrt{2\pi\hbar}} \\ &= \frac{1}{\pi^{1/4} x_0^{1/2}} \frac{\int_{-\infty}^{\infty} dx' e^{-\frac{ip'x'}{\hbar}} \exp\left(-\frac{1}{2} \left(\frac{x'}{x_0}\right)^2\right)}{\sqrt{2\pi\hbar}}, \end{aligned} \quad (5.140)$$

thus [see Eq. (5.149)]

$$\phi_0(p') = \frac{1}{\pi^{1/4} p_0^{1/2}} \exp\left(-\frac{1}{2} \left(\frac{p'}{p_0}\right)^2\right),$$

where

$$p_0 = \frac{\hbar}{x_0} = \sqrt{m\hbar\omega}. \quad (5.141)$$

3. The relation (5.56), which is a Taylor expansion of the function $f(t) = \exp(2Xt - t^2)$ around the point $t = 0$, implies that

$$H_n(X) = \left. \frac{d^n}{dt^n} \exp(2Xt - t^2) \right|_{t=0}. \quad (5.142)$$

The identity $2Xt - t^2 = X^2 - (X - t)^2$ yields

$$H_n(X) = \exp(X^2) \frac{d^n}{dt^n} \exp\left(-(X-t)^2\right) \Big|_{t=0}. \quad (5.143)$$

Moreover, using the relation

$$\frac{d}{dt} \exp\left(-(X-t)^2\right) = -\frac{d}{dX} \exp\left(-(X-t)^2\right), \quad (5.144)$$

one finds that

$$\begin{aligned} H_n(X) &= \exp(X^2) (-1)^n \frac{d^n}{dX^n} \exp\left(-(X-t)^2\right) \Big|_{t=0} \\ &= \exp(X^2) (-1)^n \frac{d^n}{dX^n} \exp(-X^2). \end{aligned} \quad (5.145)$$

Note that for an arbitrary function $g(X)$ the following holds

$$-\exp(X^2) \frac{d}{dX} \exp(-X^2) g = \left(2X - \frac{d}{dX}\right) g, \quad (5.146)$$

and

$$\exp\left(\frac{X^2}{2}\right) \left(X - \frac{d}{dX}\right) \exp\left(-\frac{X^2}{2}\right) g = \left(2X - \frac{d}{dX}\right) g, \quad (5.147)$$

thus

$$H_n(X) = \exp\left(\frac{X^2}{2}\right) \left(X - \frac{d}{dX}\right)^n \exp\left(-\frac{X^2}{2}\right). \quad (5.148)$$

4. With the help of Eq. (5.145) and the general identity

$$\int_{-\infty}^{\infty} \exp(-ax^2 + bx + c) dx = \sqrt{\frac{\pi}{a}} e^{\frac{1}{4} \frac{4ca+b^2}{a}}, \quad (5.149)$$

according to which the following holds (for the case $a = 1$, $b = 2iX$ and $c = 0$)

$$\exp(-X^2) = \frac{1}{\sqrt{\pi}} \int_{-\infty}^{\infty} \exp(-x^2 + 2iXx) dx, \quad (5.150)$$

one finds that

$$\begin{aligned}
 H_n(X) &= \frac{\exp(X^2)}{\sqrt{\pi}} \left(-\frac{d}{dX}\right)^n \int_{-\infty}^{\infty} \exp(-x^2 + 2iXx) dx \\
 &= \frac{1}{\sqrt{\pi}} \int_{-\infty}^{\infty} (-2ix)^n \exp(X^2 - x^2 + 2iXx) dx \\
 &= \frac{1}{\sqrt{\pi}} \int_{-\infty}^{\infty} (-2ix)^n e^{(X+ix)^2} dx,
 \end{aligned} \tag{5.151}$$

thus the following holds [see Eq. (5.149)]

$$\begin{aligned}
 \sum_{n=0}^{\infty} \frac{\left(\frac{\alpha}{2}\right)^n H_n(X) H_n(Y)}{n!} &= \frac{1}{\pi} \int_{-\infty}^{\infty} dx \int_{-\infty}^{\infty} dy e^{(X+ix)^2} e^{(Y+iy)^2} \underbrace{\sum_{n=0}^{\infty} \frac{(-2\alpha xy)^n}{n!}}_{e^{-2\alpha xy}} \\
 &= \frac{1}{\pi} \int_{-\infty}^{\infty} dx e^{(X+ix)^2} \underbrace{\int_{-\infty}^{\infty} dy e^{(Y+iy)^2} e^{-2\alpha xy}}_{\sqrt{\pi} e^{\alpha x(\alpha x - 2iY)}} \\
 &= \frac{1}{\sqrt{\pi}} \int_{-\infty}^{\infty} dx e^{-(1-\alpha^2)x^2 + 2i(X-Y\alpha)x + X^2} \\
 &= \frac{\exp\left(\frac{\alpha(2XY - \alpha X^2 - \alpha Y^2)}{1-\alpha^2}\right)}{\sqrt{1-\alpha^2}}.
 \end{aligned} \tag{5.152}$$

5. With the help of Eqs. (5.9), (5.10), (5.11), (5.12) and (5.13) one finds

$$\langle n|x|n\rangle = 0, \tag{5.153}$$

$$\langle n|x^2|n\rangle = \frac{\hbar}{2m\omega} \langle n|aa^\dagger + a^\dagger a|n\rangle = \frac{\hbar}{2m\omega} (2n+1), \tag{5.154}$$

$$\langle n|p|n\rangle = 0, \tag{5.155}$$

$$\langle n|p^2|n\rangle = \frac{m\hbar\omega}{2} \langle n|aa^\dagger + a^\dagger a|n\rangle = \frac{m\hbar\omega}{2} (2n+1), \tag{5.156}$$

thus

$$\langle (\Delta x)^2 \rangle \langle (\Delta p)^2 \rangle = \left(n + \frac{1}{2}\right)^2 \hbar^2.$$

6. The Hamiltonian is given by

$$\mathcal{H} = \frac{p^2}{2m}. \tag{5.157}$$

Using Eqs. (4.37) and (5.8) one finds that

$$\frac{dx^{(\text{H})}}{dt} = \frac{1}{i\hbar} [x^{(\text{H})}, \mathcal{H}^{(\text{H})}] = \frac{p^{(\text{H})}}{im\hbar} [x^{(\text{H})}, p^{(\text{H})}] = \frac{p^{(\text{H})}}{m}, \quad (5.158)$$

and

$$\frac{dp^{(\text{H})}}{dt} = \frac{1}{i\hbar} [p^{(\text{H})}, \mathcal{H}^{(\text{H})}] = 0. \quad (5.159)$$

The solution is thus

$$x^{(\text{H})}(t) = x^{(\text{H})}(0) + \frac{1}{m} p^{(\text{H})}(0) t. \quad (5.160)$$

With the help of Eq. (5.160) one finds that

$$\begin{aligned} \langle (\Delta x)^2 \rangle(t) &= \langle x^2 \rangle(t) - (\langle x \rangle(t))^2 \\ &= \langle \psi_0 | \left(x^{(\text{H})}(0) + \frac{1}{m} p^{(\text{H})}(0) t \right)^2 | \psi_0 \rangle \\ &\quad - \left(\langle \psi_0 | \left(x^{(\text{H})}(0) + \frac{1}{m} p^{(\text{H})}(0) t \right) | \psi_0 \rangle \right)^2 \\ &= (\Delta x)_0^2 + \frac{t^2}{m^2} (\Delta p)_0^2 + \frac{2t}{m} ((xp)_0 - x_0 p_0). \end{aligned} \quad (5.161)$$

7. The following holds [see Eq. (3.29)]

$$\begin{aligned} \langle \mathcal{H} \rangle &= \frac{\langle p^2 \rangle}{2m} + \frac{m\omega^2 \langle x^2 \rangle}{2} \\ &= \frac{\hbar^2}{2\pi^{1/2} m x_0^3} \int_{-\infty}^{\infty} dx' \left(1 - \left(\frac{x'}{x_0} \right)^2 \right) \exp \left(- \left(\frac{x'}{x_0} \right)^2 \right) \\ &\quad + \frac{m\omega^2 x_0}{2\pi^{1/2}} \int_{-\infty}^{\infty} dx' \left(\frac{x'}{x_0} \right)^2 \exp \left(- \left(\frac{x'}{x_0} \right)^2 \right) \\ &= \frac{\hbar^2}{4m x_0^2} + \frac{m\omega^2 x_0^2}{4}, \end{aligned} \quad (5.162)$$

The condition

$$0 = \frac{d \langle \mathcal{H} \rangle}{d(x_0^2)}, \quad (5.163)$$

yields [compare with Eq. (5.126)]

$$x_0 = \sqrt{\frac{\hbar}{m\omega}}. \quad (5.164)$$

Alternatively, the same conclusion can be reached by noticing that for any normalized state $|\psi\rangle$, the energy expectation value $\langle \mathcal{H} \rangle = \langle \psi | \mathcal{H} | \psi \rangle$ is bounded by $\langle \mathcal{H} \rangle \geq E_0$, where E_0 is the ground state energy (this can be shown by expanding $|\psi\rangle$ in the basis of energy eigenvectors $|n\rangle$).

8. With the help of the Thomas-Reiche-Kuhn sum rule (4.77) one finds that $S_n = \hbar^2 / (2m)$. The same result can be obtained using Eqs. (5.11), (5.19), (5.28) and (5.29)

$$\begin{aligned} S_n &= \frac{\hbar^2}{2m} \sum_{n'=0}^{\infty} (n' - n) |\langle n' | a + a^\dagger | n \rangle|^2 \\ &= \frac{\hbar^2}{2m} (n + 1 - n) \\ &= \frac{\hbar^2}{2m} . \end{aligned} \tag{5.165}$$

9. The Hamiltonian is given by

$$\mathcal{H} = \frac{p^2}{2m} + \frac{m\omega^2 x^2}{2} . \tag{5.166}$$

Using Eqs. (4.37) and (5.8) one finds that

$$\frac{dx^{(H)}}{dt} = \frac{1}{i\hbar} [x^{(H)}, \mathcal{H}^{(H)}] = \frac{p^{(H)}}{m} , \tag{5.167}$$

and

$$\frac{dp^{(H)}}{dt} = \frac{1}{i\hbar} [p^{(H)}, \mathcal{H}^{(H)}] = -m\omega^2 x^{(H)} . \tag{5.168}$$

- a) The solutions of the above equations are given by

$$x^{(H)}(t) = x^{(H)}(0) \cos(\omega t) + \frac{\sin(\omega t)}{m\omega} p^{(H)}(0) , \tag{5.169}$$

and

$$p^{(H)}(t) = p^{(H)}(0) \cos(\omega t) - m\omega \sin(\omega t) x^{(H)}(0) . \tag{5.170}$$

- b) Using the expressions for $x^{(H)}(t)$ and $p^{(H)}(t)$ and Eq. (5.8) one finds that

$$\begin{aligned} & [p^{(H)}(t_1), x^{(H)}(t_2)] \\ &= -(\cos(\omega t_1) \cos(\omega t_2) + \sin(\omega t_1) \sin(\omega t_2)) [x^{(H)}(0), p^{(H)}(0)] \\ &= -i\hbar \cos(\omega(t_1 - t_2)) , \end{aligned} \tag{5.171}$$

$$\begin{aligned}
& \left[p^{(H)}(t_1), p^{(H)}(t_2) \right] \\
&= m\omega (\cos(\omega t_1) \sin(\omega t_2) - \sin(\omega t_1) \cos(\omega t_2)) \left[x^{(H)}(0), p^{(H)}(0) \right] \\
&= -i\hbar m\omega \sin(\omega(t_1 - t_2)) ,
\end{aligned} \tag{5.172}$$

and

$$\begin{aligned}
& \left[x^{(H)}(t_1), x^{(H)}(t_2) \right] \\
&= \frac{1}{m\omega} (\cos(\omega t_1) \sin(\omega t_2) - \sin(\omega t_1) \cos(\omega t_2)) \left[x^{(H)}(0), p^{(H)}(0) \right] \\
&= -\frac{i\hbar}{m\omega} \sin(\omega(t_1 - t_2)) .
\end{aligned} \tag{5.173}$$

10. Due to the infinite barrier for $x \leq 0$ the wavefunction must vanish at $x = 0$. This condition is satisfied by the wavefunction of all number states $|n\rangle$ with odd value of n (the states $|n\rangle$ are eigenstates of the 'regular' harmonic oscillator with potential $V(x) = (m\omega^2/2)x^2$). These wavefunctions obviously satisfy the Schrödinger equation for $x > 0$.

a) Thus the possible energy values are

$$E_k = \hbar\omega \left(2k + \frac{3}{2} \right) , \tag{5.174}$$

where $k = 0, 1, 2, \dots$.

b) The corresponding normalized wavefunctions are given by

$$\tilde{\psi}_k(x) = \begin{cases} \sqrt{2}\psi_{2k+1}(x) & x > 0 \\ 0 & x \leq 0 \end{cases} , \tag{5.175}$$

where $\psi_n(x)$ is the wavefunction of the number states $|n\rangle$. Thus for a given k

$$\begin{aligned}
\langle x^2 \rangle_k &= \int_0^{\infty} dx \left| \tilde{\psi}_k(x) \right|^2 x^2 \\
&= 2 \int_0^{\infty} dx \left| \psi_{2k+1}(x) \right|^2 x^2 \\
&= \int_{-\infty}^{\infty} dx \left| \psi_{2k+1}(x) \right|^2 x^2 \\
&= \langle 2k+1 | x^2 | 2k+1 \rangle ,
\end{aligned} \tag{5.176}$$

thus with the help of Eq. (5.154) one finds that

$$\langle x^2 \rangle_k = \frac{\hbar}{m\omega} \left(2k + \frac{3}{2} \right) . \quad (5.177)$$

11. The potential can be written as

$$V(x) = \frac{m\omega^2}{2} \left(x + \frac{\alpha}{m\omega^2} \right)^2 - \frac{\alpha^2}{2m\omega^2} . \quad (5.178)$$

This describes a harmonic oscillator centered at $x_0 = -\alpha/m\omega^2$ having angular resonance frequency ω . The last constant term represents energy shift. Thus, the eigenenergies are given by

$$E_n = \hbar\omega (n + 1/2) - \alpha^2/2m\omega^2 , \quad (5.179)$$

where $n = 0, 1, 2, \dots$.

12. The following holds

$$|\psi(0^+)\rangle = U |\psi(0^-)\rangle , \quad (5.180)$$

where [see Eq. (4.9)]

$$\begin{aligned} U &= \exp \left(-\frac{i}{\hbar} \lim_{0 < \tau \rightarrow 0} \int_{-\tau}^{\tau} dt \mathcal{H}(t) \right) \\ &= \exp \left(\frac{im\omega_p x^2}{2\hbar} \right) . \end{aligned} \quad (5.181)$$

Note that the following hold

$$U^\dagger x U = x , \quad (5.182)$$

and [see Eq. (2.182) and (5.8)]

$$U^\dagger p U = p + m\omega_p x , \quad (5.183)$$

hence the position expectation value $\langle x \rangle$ is unaffected by the pulse and the momentum expectation value $\langle p \rangle$ is increased by $m\omega_p \langle x \rangle$.

13. In the classically forbidden region $V(x) > E_0 = \hbar\omega/2$, namely $|x| > x_0$ where

$$x_0 = \sqrt{\frac{\hbar}{m\omega}} . \quad (5.184)$$

Using Eq. (5.131) one finds

$$\begin{aligned} p &= 2 \int_{x_0}^{\infty} |\psi_0(x)|^2 dx \\ &= \frac{2}{\pi^{1/2} x_0} \int_{x_0}^{\infty} \exp \left(-\left(\frac{x}{x_0} \right)^2 \right) dx \\ &= 1 - \text{erf}(1) \\ &= 0.157 . \end{aligned} \quad (5.185)$$

14. The answer is [see Eqs. (4.255) and (5.19)]

$$E_{n_x, n_y, n_z} = \frac{\pi^2 \hbar^2 (n_x^2 + n_y^2)}{2ma^2} + \hbar\omega \left(n_z + \frac{1}{2} \right), \quad (5.186)$$

where n_x and n_y are positive integers and n_z is a nonnegative integer.

15. With the help of Eq. (4.14) one has

$$|\alpha(t)\rangle = \frac{1}{\sqrt{2}} e^{-\frac{i\omega_0 t}{2}} (|0\rangle + e^{-i\omega_0 t} |1\rangle). \quad (5.187)$$

Moreover, the following hold

$$x = \sqrt{\frac{\hbar}{2m\omega_0}} (a + a^\dagger), \quad (5.188)$$

$$p = i\sqrt{\frac{m\hbar\omega_0}{2}} (-a + a^\dagger), \quad (5.189)$$

$$a |n\rangle = \sqrt{n} |n-1\rangle, \quad (5.190)$$

$$a^\dagger |n\rangle = \sqrt{n+1} |n+1\rangle, \quad (5.191)$$

$$[a, a^\dagger] = 1, \quad (5.192)$$

thus

a)

$$\begin{aligned} \langle x \rangle &= \sqrt{\frac{\hbar}{2m\omega_0}} \langle \alpha(t) | (a + a^\dagger) | \alpha(t) \rangle \\ &= \sqrt{\frac{\hbar}{2m\omega_0}} \frac{1}{2} (\langle 0 | + e^{i\omega_0 t} \langle 1 |) (a + a^\dagger) (|0\rangle + e^{-i\omega_0 t} |1\rangle) \\ &= \sqrt{\frac{\hbar}{2m\omega_0}} \frac{1}{2} (e^{i\omega_0 t} + e^{-i\omega_0 t}) \\ &= \sqrt{\frac{\hbar}{2m\omega_0}} \cos(\omega_0 t). \end{aligned} \quad (5.193)$$

b)

$$\begin{aligned} \langle p \rangle &= i\sqrt{\frac{m\hbar\omega_0}{2}} \langle \alpha(t) | (-a + a^\dagger) | \alpha(t) \rangle \\ &= i\sqrt{\frac{m\hbar\omega_0}{2}} \frac{1}{2} (\langle 0 | + e^{i\omega_0 t} \langle 1 |) (-a + a^\dagger) (|0\rangle + e^{-i\omega_0 t} |1\rangle) \\ &= -\sqrt{\frac{m\hbar\omega_0}{2}} \sin(\omega_0 t). \end{aligned} \quad (5.194)$$

c)

$$\begin{aligned}
 \langle x^2 \rangle &= \frac{\hbar}{2m\omega_0} \langle \alpha(t) | (a + a^\dagger)^2 | \alpha(t) \rangle \\
 &= \frac{\hbar}{2m\omega_0} \langle \alpha(t) | (a^2 + (a^\dagger)^2 + [a, a^\dagger] + 2a^\dagger a) | \alpha(t) \rangle \\
 &= \frac{\hbar}{2m\omega_0} \left(1 + 2\frac{1}{2} \right) \\
 &= \frac{\hbar}{m\omega_0} .
 \end{aligned} \tag{5.195}$$

d) Similarly

$$\begin{aligned}
 \langle p^2 \rangle &= -\frac{m\hbar\omega_0}{2} \langle \alpha(t) | (-a + a^\dagger)^2 | \alpha(t) \rangle \\
 &= -\frac{m\hbar\omega_0}{2} \langle \alpha(t) | (a^2 + (a^\dagger)^2 - [a, a^\dagger] - 2a^\dagger a) | \alpha(t) \rangle \\
 &= m\hbar\omega_0 ,
 \end{aligned} \tag{5.196}$$

thus

$$\begin{aligned}
 \Delta x \Delta p &= \hbar \sqrt{1 - \frac{\cos^2(\omega_0 t)}{2}} \sqrt{1 - \frac{\sin^2(\omega_0 t)}{2}} \\
 &= \frac{\hbar}{2} \sqrt{2 + \frac{1}{4} \sin^2(2\omega_0 t)} .
 \end{aligned} \tag{5.197}$$

16. The state $|\psi(t)\rangle$ is given by

$$|\psi(t)\rangle = \frac{1}{\sqrt{2}} \left[\exp\left(-\frac{iE_0 t}{\hbar}\right) |0\rangle + \exp\left(-\frac{iE_n t}{\hbar}\right) |n\rangle \right] , \tag{5.198}$$

where

$$E_n = \hbar\omega \left(n + \frac{1}{2} \right) , \tag{5.199}$$

thus, using

$$x = \sqrt{\frac{\hbar}{2m\omega}} (a + a^\dagger) , \tag{5.200}$$

and

$$a |n\rangle = \sqrt{n} |n-1\rangle , \tag{5.201}$$

$$a^\dagger |n\rangle = \sqrt{n+1} |n+1\rangle , \tag{5.202}$$

one finds that $\langle x \rangle(t) = 0$ if $n > 1$, and for $n = 1$

$$\begin{aligned}
\langle x \rangle (t) &= \sqrt{\frac{\hbar}{2m\omega}} \langle \psi(t) | (a + a^\dagger) | \psi(t) \rangle \\
&= \sqrt{\frac{\hbar}{2m\omega}} \cos(\omega t) .
\end{aligned} \tag{5.203}$$

17. Since $\langle \mathcal{H} \rangle = \hbar\omega$ and $|\psi(0)\rangle$ is normalized one has

$$|c_0|^2 = |c_1|^2 = \frac{1}{2}, \tag{5.204}$$

thus $|\psi(0)\rangle$ can be written as

$$|\psi(0)\rangle = \sqrt{\frac{1}{2}} (|0\rangle + e^{i\theta} |1\rangle), \tag{5.205}$$

where θ is real. Given that at time $t = 0$

$$\langle x \rangle (t = 0) = \frac{1}{2} \sqrt{\frac{\hbar}{m\omega}}, \tag{5.206}$$

one finds using the identities

$$x = \sqrt{\frac{\hbar}{2m\omega}} (a + a^\dagger), \tag{5.207}$$

$$a |n\rangle = \sqrt{n} |n-1\rangle, \tag{5.208}$$

$$a^\dagger |n\rangle = \sqrt{n+1} |n+1\rangle, \tag{5.209}$$

that

$$\cos \theta = \frac{\sqrt{2}}{2}. \tag{5.210}$$

Using this result one can evaluate $\langle p \rangle (t = 0)$, where

$$p = i \sqrt{\frac{m\hbar\omega}{2}} (-a + a^\dagger), \tag{5.211}$$

thus

$$\langle p \rangle (t = 0) = \sqrt{\frac{m\hbar\omega}{2}} \sin \theta = \pm \sqrt{\frac{m\hbar\omega}{2}} \frac{\sqrt{2}}{2} = \pm m\omega \langle x \rangle (t = 0). \tag{5.212}$$

Using these results together with Eq. (5.169) yields

$$\begin{aligned}
\langle x \rangle (t) &= \frac{1}{2} \sqrt{\frac{\hbar}{m\omega}} (\cos(\omega t) \pm \sin(\omega t)) \\
&= \sqrt{\frac{\hbar}{2m\omega}} \cos\left(\omega t \mp \frac{\pi}{4}\right).
\end{aligned} \tag{5.213}$$

18. According to identity (2.184), which states that

$$e^{A+B} = e^A e^B e^{-\frac{1}{2}[A,B]} = e^B e^A e^{\frac{1}{2}[A,B]} , \quad (5.214)$$

provided that

$$[A, [A, B]] = [B, [A, B]] = 0 , \quad (5.215)$$

one finds with the help of Eq. (5.13) that

$$\begin{aligned} D(\alpha) &= \exp(\alpha a^\dagger - \alpha^* a) \\ &= e^{-\frac{|\alpha|^2}{2}} e^{\alpha a^\dagger} e^{-\alpha^* a} \\ &= e^{\frac{|\alpha|^2}{2}} e^{-\alpha^* a} e^{\alpha a^\dagger} . \end{aligned} \quad (5.216)$$

19. Using Eq. (5.216) one has

$$D^\dagger(\alpha) = e^{-\frac{|\alpha|^2}{2}} e^{-\alpha a^\dagger} e^{\alpha^* a} = e^{\frac{|\alpha|^2}{2}} e^{\alpha^* a} e^{-\alpha a^\dagger} , \quad (5.217)$$

thus

$$D^\dagger(\alpha) D(\alpha) = D(\alpha) D^\dagger(\alpha) = 1 . \quad (5.218)$$

20. Using Eqs. (5.35), (5.28) and (5.29) one finds that

$$\begin{aligned} |\alpha\rangle &= e^{-\frac{|\alpha|^2}{2}} e^{\alpha a^\dagger} e^{-\alpha^* a} |0\rangle = e^{-\frac{|\alpha|^2}{2}} e^{\alpha a^\dagger} |0\rangle \\ &= e^{-\frac{|\alpha|^2}{2}} \sum_{n=0}^{\infty} \frac{\alpha^n}{\sqrt{n!}} |n\rangle . \end{aligned} \quad (5.219)$$

21. Using Eqs. (5.42) and (5.28) one has

$$\begin{aligned} a|\alpha\rangle &= e^{-\frac{|\alpha|^2}{2}} \sum_{n=0}^{\infty} \frac{\alpha^n}{\sqrt{n!}} a|n\rangle \\ &= \alpha e^{-\frac{|\alpha|^2}{2}} \sum_{n=1}^{\infty} \frac{\alpha^{n-1}}{\sqrt{(n-1)!}} |n-1\rangle \\ &= \alpha |\alpha\rangle . \end{aligned} \quad (5.220)$$

22. Using Eqs. (5.36), (5.9) and (5.10) one has

$$D(\alpha) = \exp \left[\sqrt{\frac{m\omega}{2\hbar}} (\alpha - \alpha^*) x - i \sqrt{\frac{1}{2\hbar m\omega}} (\alpha + \alpha^*) p \right] , \quad (5.221)$$

thus with the help of Eqs. (2.184) and (5.8) the desired result is obtained

$$D(\alpha) = \exp\left(\sqrt{\frac{m\omega}{\hbar}} \frac{\alpha - \alpha^*}{\sqrt{2}} x\right) \times \exp\left(-\frac{i}{\sqrt{m\hbar\omega}} \frac{\alpha + \alpha^*}{\sqrt{2}} p\right) \exp\left(\frac{\alpha^{*2} - \alpha^2}{4}\right). \quad (5.222)$$

23. Using the operator identity (2.182)

$$e^L A e^{-L} = A + [L, A] + \frac{1}{2!} [L, [L, A]] + \frac{1}{3!} [L, [L, [L, A]]] + \dots, \quad (5.223)$$

and the definition (5.36)

$$D(\alpha) = \exp(\alpha a^\dagger - \alpha^* a), \quad (5.224)$$

one finds that

$$D^\dagger(\alpha) a D(\alpha) = a + \alpha, \quad (5.225)$$

$$D^\dagger(\alpha) a^\dagger D(\alpha) = a^\dagger + \alpha^*. \quad (5.226)$$

Exploiting the unitarity of $D(\alpha)$

$$D(\alpha) D^\dagger(\alpha) = 1$$

it is straightforward to show that for any function $f(a, a^\dagger)$ having a power series expansion the following holds

$$D^\dagger(\alpha) f(a, a^\dagger) D(\alpha) = f(a + \alpha, a^\dagger + \alpha^*) \quad (5.227)$$

(e.g., $D^\dagger a^2 D = D^\dagger a D D^\dagger a D = (a + \alpha)^2$).

24. Using Eq. (5.81) and the following identities

$$\mathcal{H} = \hbar\omega \left(a^\dagger a + \frac{1}{2} \right), \quad (5.228)$$

$$x = \sqrt{\frac{\hbar}{2m\omega}} (a + a^\dagger), \quad (5.229)$$

$$p = i\sqrt{\frac{m\hbar\omega}{2}} (-a + a^\dagger), \quad (5.230)$$

all these relations are easily obtained.

25. Expressing the state $|\alpha\rangle$ in the basis of eigenvectors of the Hamiltonian $|n\rangle$

$$|\alpha\rangle = \sum_{n=0}^{\infty} c_n |n\rangle, \quad (5.231)$$

using

$$a|\alpha\rangle = \alpha|\alpha\rangle, \quad (5.232)$$

and

$$a|n\rangle = \sqrt{n}|n-1\rangle, \quad (5.233)$$

one finds

$$\sum_{n=0}^{\infty} c_n \sqrt{n}|n-1\rangle = \alpha \sum_{n=0}^{\infty} c_n |n\rangle, \quad (5.234)$$

thus

$$c_{n+1} = \frac{\alpha}{\sqrt{n+1}} c_n, \quad (5.235)$$

therefore

$$|\alpha\rangle = A \sum_{n=0}^{\infty} \frac{\alpha^n}{\sqrt{n!}} |n\rangle. \quad (5.236)$$

The normalization constant A is found by

$$1 = |A|^2 \sum_{n=0}^{\infty} \frac{(|\alpha|^2)^n}{n!} = |A|^2 e^{|\alpha|^2}. \quad (5.237)$$

Choosing A to be real yields

$$A = e^{-\frac{|\alpha|^2}{2}}, \quad (5.238)$$

thus

$$c_n = e^{-\frac{|\alpha|^2}{2}} \frac{\alpha^n}{\sqrt{n!}}. \quad (5.239)$$

Note that this result is identical to Eq. (5.42), thus $|\alpha\rangle$ is a coherent state. The possible results of the measurement are

$$E_n = \hbar\omega \left(n + \frac{1}{2} \right), \quad (5.240)$$

and the corresponding probabilities, which are time independent, are given by

$$p_n(t) = |c_n|^2 = e^{-|\alpha|^2} \frac{(|\alpha|^2)^n}{n!}. \quad (5.241)$$

26. Using the relations

$$\langle x \rangle_\alpha = \sqrt{\frac{2\hbar}{m\omega}} \operatorname{Re}(\alpha) , \quad (5.242)$$

$$\langle p \rangle_\alpha = \sqrt{2\hbar m\omega} \operatorname{Im}(\alpha) , \quad (5.243)$$

Eq. (5.80) can be written as

$$D(\alpha) = \exp\left(\frac{i\langle p \rangle_\alpha x}{\hbar}\right) \exp\left(-\frac{i\langle x \rangle_\alpha p}{\hbar}\right) \exp\left(\frac{\alpha^{*2} - \alpha^2}{4}\right) . \quad (5.244)$$

Using Eqs. (3.12) and (3.19) one finds that

$$\exp\left(-\frac{i\langle x \rangle_\alpha p}{\hbar}\right) |x'\rangle = |x' + \langle x \rangle_\alpha\rangle ,$$

thus

$$\begin{aligned} \langle x' | \alpha \rangle &= \langle x' | \exp\left(\frac{i\langle p \rangle_\alpha x}{\hbar}\right) \exp\left(-\frac{i\langle x \rangle_\alpha p}{\hbar}\right) \exp\left(\frac{\alpha^{*2} - \alpha^2}{4}\right) |0\rangle \\ &= \exp\left(\frac{\alpha^{*2} - \alpha^2}{4}\right) \exp\left(\frac{i\langle p \rangle_\alpha x'}{\hbar}\right) \langle x' - \langle x \rangle_\alpha | 0 \rangle . \end{aligned} \quad (5.245)$$

Using Eq. (5.131) the wavefunction of the ground state is given by

$$\langle x' | 0 \rangle = \frac{1}{(2\pi)^{1/4}} \frac{1}{\sqrt{\Delta x_\alpha}} \exp\left(-\left(\frac{x'}{2\Delta x_\alpha}\right)^2\right) , \quad (5.246)$$

where

$$\Delta x_\alpha = \sqrt{\frac{\hbar}{2m\omega}} , \quad (5.247)$$

thus

$$\begin{aligned} \langle x' | \alpha \rangle &= \exp\left(\frac{\alpha^{*2} - \alpha^2}{4}\right) \exp\left(\frac{i\langle p \rangle_\alpha x'}{\hbar}\right) \frac{\exp\left(-\left(\frac{x' - \langle x \rangle_\alpha}{2\Delta x_\alpha}\right)^2\right)}{(2\pi)^{1/4} \sqrt{\Delta x_\alpha}} \\ &= \exp\left(\frac{\alpha^{*2} - \alpha^2}{4}\right) \left(\frac{m\omega}{\pi\hbar}\right)^{1/4} \exp\left[-\left(\frac{x - \langle x \rangle_\alpha}{2\Delta x_\alpha}\right)^2 + i\langle p \rangle_\alpha \frac{x}{\hbar}\right] . \end{aligned} \quad (5.248)$$

27. Using Eqs. (5.36) and (2.184) this relation is easily obtained.

28. With the help of Eq. (5.42) one has

$$\frac{1}{\pi} \int \int |\alpha\rangle \langle \alpha| d^2\alpha = \frac{1}{\pi} \sum_{n,m} |n\rangle \langle m| \frac{1}{\sqrt{n!m!}} \int \int e^{-|\alpha|^2} \alpha^n \alpha^{*m} d^2\alpha .$$

(5.249)

Employing polar coordinates in the complex plane $\alpha = \rho e^{i\theta}$, where ρ is non-negative real and θ is real, leads to

$$\begin{aligned}
 \frac{1}{\pi} \int \int |\alpha\rangle \langle \alpha| d^2\alpha &= \frac{1}{\pi} \sum_{n,m} |n\rangle \langle m| \frac{1}{\sqrt{n!m!}} \int_0^\infty d\rho \rho^{n+m+1} e^{-\rho^2} \underbrace{\int_0^{2\pi} d\theta e^{i\theta(n-m)}}_{2\pi\delta_{nm}} \\
 &= \sum_n |n\rangle \langle n| \frac{2}{n!} \int_0^\infty d\rho \rho^{2n+1} e^{-\rho^2} \\
 &= \sum_n |n\rangle \langle n| \frac{1}{n!} \underbrace{\Gamma(n+1)}_{=n!} \\
 &= \sum_n |n\rangle \langle n| \\
 &= 1 .
 \end{aligned}$$

(5.250)

29. Using Eqs. (5.35) and (5.41) one finds that

$$\begin{aligned}
 \langle \beta | \alpha \rangle &= \langle 0 | D^\dagger(\beta) D(\alpha) | 0 \rangle \\
 &= \langle 0 | D(-\beta) D(\alpha) | 0 \rangle \\
 &= \exp\left(\frac{-\beta\alpha^* + \beta^*\alpha}{2}\right) \langle 0 | D(-\beta + \alpha) | 0 \rangle \\
 &= \exp\left(\frac{-\beta\alpha^* + \beta^*\alpha}{2}\right) \langle 0 | \alpha - \beta \rangle .
 \end{aligned}$$

(5.251)

Thus, with the help of Eq. (5.42) one has

$$\begin{aligned}
 \langle \beta | \alpha \rangle &= \exp\left(\frac{-\beta\alpha^* + \beta^*\alpha}{2}\right) e^{-\frac{|\alpha-\beta|^2}{2}} \\
 &= \exp\left(-\frac{|\alpha|^2}{2} - \frac{|\beta|^2}{2} + \alpha\beta^*\right) \\
 &= \exp\left(-\frac{|\alpha-\beta|^2}{2} + i \operatorname{Im}(\alpha\beta^*)\right) .
 \end{aligned}$$

(5.252)

30. In the basis of the number states $|n\rangle$

$$\operatorname{Tr} A = \sum_{n=0}^{\infty} \langle n | A | n \rangle , \tag{5.253}$$

thus [see Eq. (5.52)]

$$\begin{aligned}
\text{Tr } A &= \frac{1}{\pi^2} \sum_{n=0}^{\infty} \langle n | \left(\int d^2\alpha' |\alpha'\rangle \langle\alpha'| \right) A \left(\int d^2\alpha'' |\alpha''\rangle \langle\alpha''| \right) |n\rangle \\
&= \frac{1}{\pi^2} \int d^2\alpha' \int d^2\alpha'' \langle\alpha'| A |\alpha''\rangle \langle\alpha''| \left(\sum_{n=0}^{\infty} |n\rangle \langle n| \right) |\alpha'\rangle \\
&= \frac{1}{\pi} \int d^2\alpha' \langle\alpha'| A \left(\frac{1}{\pi} \int d^2\alpha'' |\alpha''\rangle \langle\alpha''| \right) |\alpha'\rangle \\
&= \frac{1}{\pi} \int d^2\alpha' \langle\alpha'| A |\alpha'\rangle .
\end{aligned} \tag{5.254}$$

31. The following holds [see Eqs. (2.134) and (5.39)]

$$\begin{aligned}
\text{Tr} [D(\alpha') D(\alpha'')] &= \text{Tr} \left(e^{-\frac{|\alpha'|^2}{2}} e^{\alpha' a^\dagger} e^{-\alpha'^* a} e^{\frac{|\alpha''|^2}{2}} e^{-\alpha''^* a} e^{\alpha'' a^\dagger} \right) \\
&= e^{\frac{|\alpha''|^2}{2} - \frac{|\alpha'|^2}{2}} \text{Tr} \left(e^{(\alpha'+\alpha'') a^\dagger} e^{-(\alpha'+\alpha'')^* a} \right) ,
\end{aligned} \tag{5.255}$$

thus [see Eqs. (5.87) and (4.47)]

$$\begin{aligned}
&\text{Tr} [D(\alpha') D(\alpha'')] \\
&= \frac{1}{\pi} e^{\frac{|\alpha''|^2}{2} - \frac{|\alpha'|^2}{2}} \int d^2\alpha''' \langle\alpha'''| e^{(\alpha'+\alpha'') a^\dagger} e^{-(\alpha'+\alpha'')^* a} |\alpha'''\rangle \\
&= \frac{1}{\pi} e^{\frac{|\alpha''|^2}{2} - \frac{|\alpha'|^2}{2}} \int d^2\alpha''' e^{(\alpha'+\alpha'')\alpha'''^* - (\alpha'+\alpha'')^* \alpha'''} .
\end{aligned} \tag{5.256}$$

Using the notation $\alpha' + \alpha'' = x + iy$ and $\alpha''' = x''' + iy'''$, where x, y, x''' and y''' are all real, one finds that [see Eq. (4.47)]

$$\begin{aligned}
\int d^2\alpha''' e^{(\alpha'+\alpha'')\alpha'''^* - (\alpha'+\alpha'')^* \alpha'''} &= \int_{-\infty}^{\infty} dx''' e^{2iyx'''} \int_{-\infty}^{\infty} dy''' e^{-2ixy'''} \\
&= \pi^2 \delta(y) \delta(x) ,
\end{aligned} \tag{5.257}$$

hence Eq. (5.88) holds.

32. The following holds

$$\begin{aligned}
V_1(x) &= \frac{1}{2} m\omega^2 (x + \beta)^2 - \frac{1}{2} m\omega^2 \beta^2 \\
&= \frac{1}{2} m\omega^2 x'^2 - \frac{1}{2} m\omega^2 \beta^2 ,
\end{aligned} \tag{5.258}$$

where

$$x' = x + \beta . \quad (5.259)$$

a) Thus, using Eqs. (5.169) and (5.170) together with the relations

$$x^{(\text{H})}(t) = x^{(\text{H})}(t) + \beta , \quad (5.260)$$

$$p^{(\text{H})}(t) = p^{(\text{H})}(t) , \quad (5.261)$$

one finds

$$x^{(\text{H})}(t) = \left(x^{(\text{H})}(0) + \beta \right) \cos(\omega t) + \frac{\sin(\omega t)}{m\omega} p^{(\text{H})}(0) - \beta , \quad (5.262)$$

$$p^{(\text{H})}(t) = p^{(\text{H})}(0) \cos(\omega t) - m\omega \sin(\omega t) \left(x^{(\text{H})}(0) + \beta \right) . \quad (5.263)$$

b) For this case at time $t = 0$

$$\langle x^{(\text{H})}(0) \rangle = 0 , \quad (5.264)$$

$$\langle p^{(\text{H})}(0) \rangle = 0 , \quad (5.265)$$

thus

$$\langle x^{(\text{H})}(t) \rangle = \beta (\cos(\omega t) - 1) . \quad (5.266)$$

33. The state of the system at time $t = 0$ is given by [see Eq. (3.12)]

$$|\psi(t=0)\rangle = \exp\left(-\frac{i\Delta_x}{\hbar} p\right) |0\rangle , \quad (5.267)$$

where $|0\rangle$ is the ground state of the potential V_2 . In general a coherent state with parameter α can be written as [see Eq. (5.40)]

$$|\alpha\rangle = \exp\left(\sqrt{\frac{m\omega}{\hbar}} \frac{\alpha - \alpha^*}{\sqrt{2}} x\right) \exp\left(-\frac{i}{\sqrt{m\hbar\omega}} \frac{\alpha + \alpha^*}{\sqrt{2}} p\right) \exp\left(\frac{\alpha^{*2} - \alpha^2}{4}\right) |0\rangle . \quad (5.268)$$

a) Thus $|\psi(t=0)\rangle = |\alpha_0\rangle$, where

$$\alpha_0 = \Delta_x \sqrt{\frac{m\omega}{2\hbar}} . \quad (5.269)$$

The time evolution of a coherent state is given by

$$|\psi(t)\rangle = e^{-i\omega t/2} |\alpha = \alpha_0 e^{-i\omega t}\rangle , \quad (5.270)$$

and the following holds

$$\langle x \rangle (t) = \sqrt{\frac{2\hbar}{m\omega}} \text{Re} [\alpha_0 e^{-i\omega t}] = \Delta_x \cos(\omega t) , \quad (5.271)$$

b) According to Eq. (5.48)

$$\langle (\Delta x)^2 \rangle (t) = \frac{\hbar}{2m\omega} . \quad (5.272)$$

c) In general a coherent state can be expanded in the basis of number states $|n\rangle$

$$|\alpha\rangle = e^{-|\alpha|^2/2} \sum_n \frac{\alpha^n}{\sqrt{n!}} |n\rangle , \quad (5.273)$$

thus the probability to measure energy $E_n = \hbar\omega (N + 1/2)$ at time t is given by

$$P_n = |\langle n|\psi(t)\rangle|^2 = \frac{e^{-|\alpha_0|^2} |\alpha_0|^{2n}}{n!} = \frac{1}{n!} \exp\left(-\frac{m\omega\Delta_x^2}{2\hbar}\right) \left(\frac{m\omega\Delta_x^2}{2\hbar}\right)^n . \quad (5.274)$$

34. At time $t = 0$ the following holds

$$\langle x \rangle = 0 , \quad (5.275)$$

$$\langle p \rangle = 0 , \quad (5.276)$$

$$\langle (\Delta x)^2 \rangle = \langle x^2 \rangle = \frac{\hbar}{2m\omega} , \quad (5.277)$$

$$\langle (\Delta p)^2 \rangle = \langle p^2 \rangle = \frac{\hbar m\omega}{2} . \quad (5.278)$$

Moreover, to calculate $\langle xp \rangle$ it is convenient to use

$$x = \sqrt{\frac{\hbar}{2m\omega}} (a + a^\dagger) , \quad (5.279)$$

$$p = i\sqrt{\frac{m\hbar\omega}{2}} (-a + a^\dagger) , \quad (5.280)$$

$$[a, a^\dagger] = 1 , \quad (5.281)$$

thus at time $t = 0$

$$\langle xp \rangle = i\frac{\hbar}{2} \langle 0|aa^\dagger - a^\dagger a|0\rangle = i\frac{\hbar}{2} . \quad (5.282)$$

The Hamiltonian for times $t > 0$ is given by

$$\mathcal{H} = \frac{p^2}{2m} + gx . \quad (5.283)$$

Using the Heisenberg equation of motion for the operators x and x^2 one finds

$$\frac{dx_{(\text{H})}}{dt} = \frac{1}{i\hbar} [x_{(\text{H})}, \mathcal{H}] , \quad (5.284)$$

$$\frac{dp_{(\text{H})}}{dt} = \frac{1}{i\hbar} [p_{(\text{H})}, \mathcal{H}] , \quad (5.285)$$

$$\frac{dx_{(\text{H})}^2}{dt} = \frac{1}{i\hbar} [x_{(\text{H})}^2, \mathcal{H}] , \quad (5.286)$$

or using $[x, p] = i\hbar$

$$\frac{dx_{(\text{H})}}{dt} = \frac{p_{(\text{H})}}{m} , \quad (5.287)$$

$$\frac{dp_{(\text{H})}}{dt} = -g , \quad (5.288)$$

$$\frac{dx_{(\text{H})}^2}{dt} = \frac{1}{m} (x_{(\text{H})}p_{(\text{H})} + p_{(\text{H})}x_{(\text{H})}) = \frac{1}{m} (2x_{(\text{H})}p_{(\text{H})} - i\hbar) , \quad (5.289)$$

thus

$$p_{(\text{H})}(t) = p_{(\text{H})}(0) - gt , \quad (5.290)$$

$$x_{(\text{H})}(t) = x_{(\text{H})}(0) + \frac{p_{(\text{H})}(0)t}{m} - \frac{gt^2}{2m} , \quad (5.291)$$

$$\begin{aligned} x_{(\text{H})}^2(t) &= x_{(\text{H})}^2(0) - \frac{i\hbar t}{m} + \frac{2}{m} \int_0^t x_{(\text{H})}(t') p_{(\text{H})}(t') dt' \\ &= x_{(\text{H})}^2(0) - \frac{i\hbar t}{m} + \frac{2}{m} \int_0^t \left(x_{(\text{H})}(0) + \frac{p_{(\text{H})}(0)t'}{m} - \frac{gt'^2}{2m} \right) [p_{(\text{H})}(0) - gt'] dt' \\ &= x_{(\text{H})}^2(0) - \frac{i\hbar t}{m} \\ &\quad + \frac{2}{m} \int_0^t \left(x_{(\text{H})}(0) p_{(\text{H})}(0) + \frac{p_{(\text{H})}^2(0)t'}{m} - \frac{gt'^2}{2m} p_{(\text{H})}(0) - x_{(\text{H})}(0) gt' - \frac{p_{(\text{H})}(0)gt'^2}{m} + \frac{g^2t'^3}{2m} \right) dt' \\ &= x_{(\text{H})}^2(0) - \frac{i\hbar t}{m} \\ &\quad + \frac{2}{m} \left(x_{(\text{H})}(0) p_{(\text{H})}(0) t + \frac{p_{(\text{H})}^2(0)t^2}{2m} - \frac{p_{(\text{H})}(0)gt^3}{6m} - \frac{x_{(\text{H})}(0)gt^2}{2} - \frac{p_{(\text{H})}(0)gt^3}{3m} + \frac{g^2t^4}{8m} \right) . \end{aligned} \quad (5.292)$$

Using the initial conditions Eqs. (5.275), (5.276), (5.277), (5.278) and (5.282) one finds

$$\langle x(t) \rangle = -\frac{gt^2}{2m} , \quad (5.293)$$

$$\langle x(t) \rangle^2 = \frac{g^2t^4}{4m^2} , \quad (5.294)$$

$$\langle p(t) \rangle = -gt , \quad (5.295)$$

$$\langle x^2(t) \rangle = \frac{\hbar}{2m\omega} - \frac{i\hbar t}{m} + \frac{2}{m} \left(\frac{i\hbar t}{2} + \frac{\hbar\omega t^2}{4} + \frac{g^2 t^4}{8m} \right) , \quad (5.296)$$

and

$$\langle (\Delta x)^2(t) \rangle = \langle x^2(t) \rangle - \langle x(t) \rangle^2 = \frac{\hbar}{2m\omega} + \frac{\hbar\omega t^2}{2m} = \frac{\hbar}{2m\omega} (1 + \omega^2 t^2) . \quad (5.297)$$

35. Using the operator identity (2.182), which is given by

$$e^L O e^{-L} = O + [L, O] + \frac{1}{2!} [L, [L, O]] + \frac{1}{3!} [L, [L, [L, O]]] + \dots , \quad (5.298)$$

for the operators

$$O = a , \quad (5.299)$$

$$L = \frac{r}{2} \left((a^\dagger)^2 - a^2 \right) , \quad (5.300)$$

and the relations

$$[a, a^\dagger] = 1 , \quad (5.301)$$

$$[L, O] = -ra^\dagger , \quad (5.302)$$

$$[L, [L, O]] = r^2 a , \quad (5.303)$$

$$[L, [L, [L, O]]] = -r^3 a^\dagger , \quad (5.304)$$

$$[L, [L, [L, [L, O]]]] = r^4 a , \quad (5.305)$$

etc., one finds

$$T = \left(1 + \frac{r^2}{2!} + \frac{r^4}{4!} + \dots \right) a - \left(r + \frac{r^3}{3!} + \dots \right) a^\dagger + \dots , \quad (5.306)$$

a) Thus

$$T = Aa + Ba^\dagger , \quad (5.307)$$

where

$$A = \cosh r , \quad (5.308)$$

$$B = -\sinh r . \quad (5.309)$$

b) Using the relations

$$x = \sqrt{\frac{\hbar}{2m\omega}} (a + a^\dagger) , \quad (5.310)$$

$$p = i\sqrt{\frac{m\hbar\omega}{2}} (-a + a^\dagger) . \quad (5.311)$$

one finds

$$\begin{aligned}
 \langle r|x|r\rangle &= \sqrt{\frac{\hbar}{2m\omega}} \langle 0|S(r)(a+a^\dagger)S^\dagger(r)|0\rangle \\
 &= \sqrt{\frac{\hbar}{2m\omega}} (\langle 0|T|0\rangle + \langle 0|T^\dagger|0\rangle) \\
 &= 0,
 \end{aligned} \tag{5.312}$$

$$\begin{aligned}
 \langle r|p|r\rangle &= i\sqrt{\frac{m\hbar\omega}{2}} \langle 0|S(r)(-a+a^\dagger)S^\dagger(r)|0\rangle \\
 &= \sqrt{\frac{\hbar}{2m\omega}} (-\langle 0|T|0\rangle + \langle 0|T^\dagger|0\rangle) \\
 &= 0.
 \end{aligned} \tag{5.313}$$

c) Note that $S(r)$ is unitary, namely $S^\dagger(r)S(r) = 1$, since the operator $a^2 - (a^\dagger)^2$ is anti Hermitian. Thus

$$\begin{aligned}
 \langle r|x^2|r\rangle &= \frac{\hbar}{2m\omega} \langle 0|S(r)(a+a^\dagger)(a+a^\dagger)S^\dagger(r)|0\rangle \\
 &= \frac{\hbar}{2m\omega} \langle 0|S(r)(a+a^\dagger)S^\dagger(r)S(r)(a+a^\dagger)S^\dagger(r)|0\rangle \\
 &= \frac{\hbar}{2m\omega} \langle 0|(T+T^\dagger)^2|0\rangle \\
 &= \frac{\hbar(A+B)^2}{2m\omega} \langle 0|(a+a^\dagger)^2|0\rangle \\
 &= \frac{\hbar(\cosh r - \sinh r)^2}{2m\omega} \\
 &= \frac{\hbar e^{-2r}}{2m\omega},
 \end{aligned} \tag{5.314}$$

and

$$\begin{aligned}
 \langle r|p^2|r\rangle &= \frac{m\hbar\omega}{2} \langle 0|S(r)(a-a^\dagger)^2S^\dagger(r)|0\rangle \\
 &= \frac{m\hbar\omega}{2} \langle 0|(T-T^\dagger)^2|0\rangle \\
 &= \frac{m\hbar\omega(A-B)^2}{2} \langle 0|(a-a^\dagger)^2|0\rangle \\
 &= \frac{m\hbar\omega(\cosh r + \sinh r)^2}{2} \\
 &= \frac{m\hbar\omega e^{2r}}{2}.
 \end{aligned} \tag{5.315}$$

Thus

$$(\Delta x)^2 = \frac{\hbar e^{-2r}}{2m\omega}, \quad (5.316)$$

$$(\Delta p)^2 = \frac{m\hbar\omega e^{2r}}{2}, \quad (5.317)$$

$$(\Delta x)(\Delta p) = \frac{\hbar}{2}. \quad (5.318)$$

36. Using the relation [see Eq. (5.307)]

$$S(r) a S^\dagger(r) = \cosh ra - \sinh ra^\dagger, \quad (5.319)$$

one obtains

$$\begin{aligned} g^{(2)} &= \frac{\langle 0 | S(r) a^\dagger S^\dagger(r) S(r) a^\dagger S^\dagger(r) S(r) a S^\dagger(r) S(r) a S^\dagger(r) | 0 \rangle}{\langle 0 | S(r) a^\dagger S^\dagger(r) S(r) a S^\dagger(r) | 0 \rangle^2} \\ &= \frac{\langle 0 | (\cosh ra^\dagger - \sinh ra)^2 (\cosh ra - \sinh ra^\dagger)^2 | 0 \rangle}{\langle 0 | (\cosh ra^\dagger - \sinh ra) (\cosh ra - \sinh ra^\dagger) | 0 \rangle^2} \\ &= \frac{\sinh^2 r (\cosh^2 r + 2 \sinh^2 r)}{\sinh^4 r}, \end{aligned} \quad (5.320)$$

or (recall that $\cosh^2 r - \sinh^2 r = 1$)

$$g^{(2)} = 3 + \frac{1}{\sinh^2 r}. \quad (5.321)$$

37. With the help of Eqs. (5.9) and (5.10) one finds that

$$x = e^{-r} \sqrt{\frac{\hbar}{2m\omega}} (Q(r) + Q^\dagger(r)), \quad (5.322)$$

$$p = -ie^r \sqrt{\frac{\hbar m\omega}{2}} (Q(r) - Q^\dagger(r)), \quad (5.323)$$

thus with the help of Eq. (5.96) one finds that

$$\langle r | x | r \rangle = 0, \quad (5.324)$$

$$\langle r | p | r \rangle = 0. \quad (5.325)$$

Using the commutation relation

$$[Q(r), Q^\dagger(r)] = (\cosh^2 r - \sinh^2 r) [a, a^\dagger] = 1,$$

one obtains

$$\begin{aligned} \langle r | x^2 | r \rangle &= \frac{\hbar e^{-2r}}{2m\omega} \langle r | (Q(r) + Q^\dagger(r))^2 | r \rangle \\ &= \frac{\hbar e^{-2r}}{2m\omega} \langle r | Q(r) Q^\dagger(r) | r \rangle \\ &= \frac{\hbar e^{-2r}}{2m\omega}, \end{aligned} \quad (5.326)$$

and similarly

$$\begin{aligned}\langle r|p^2|r\rangle &= -\frac{\hbar m\omega e^{2r}}{2}\langle r|(Q(r)-Q^\dagger(r))^2|r\rangle \\ &= \frac{\hbar m\omega e^{2r}}{2}\langle r|Q(r)Q^\dagger(r)|r\rangle \\ &= \frac{\hbar m\omega e^{2r}}{2},\end{aligned}\tag{5.327}$$

thus

$$(\Delta x)^2 = \frac{\hbar e^{-2r}}{2m\omega},\tag{5.328}$$

$$(\Delta p)^2 = \frac{\hbar m\omega e^{2r}}{2}.\tag{5.329}$$

38. Using the commutation relation

$$[a, a^\dagger] = 1,\tag{5.330}$$

one finds

$$\mathcal{H} = \hbar\omega_0 N + \hbar\omega_1 (N^2 - N),\tag{5.331}$$

where

$$N = a^\dagger a\tag{5.332}$$

is the number operator.

a) The eigenvectors of N

$$N|n\rangle = n|n\rangle,\tag{5.333}$$

(where $n = 0, 1, \dots$) are also eigenvectors of \mathcal{H} and the following holds

$$\mathcal{H}|n\rangle = E_n|n\rangle,\tag{5.334}$$

where

$$E_n = \hbar[\omega_0 n + \omega_1(n^2 - n)].\tag{5.335}$$

Note that

$$\frac{E_{n+1} - E_n}{\hbar} = \omega_0 + 2\omega_1 n,\tag{5.336}$$

thus $E_{n+1} > E_n$.

b) Using the relations

$$x = \sqrt{\frac{\hbar}{2m\omega_0}} (a^\dagger + a) , \quad (5.337)$$

$$p = i\sqrt{\frac{m\hbar\omega_0}{2}} (a^\dagger - a) , \quad (5.338)$$

$$x^2 = \frac{\hbar}{2m\omega_0} (a^\dagger a^\dagger + aa + 2N + 1) , \quad (5.339)$$

$$p^2 = \frac{m\hbar\omega_0}{2} (-a^\dagger a^\dagger - aa + 2N + 1) , \quad (5.340)$$

$$a |n\rangle = \sqrt{n} |n-1\rangle , \quad (5.341)$$

$$a^\dagger |n\rangle = \sqrt{n+1} |n+1\rangle , \quad (5.342)$$

one finds

i. $\langle 0|x|0\rangle = 0$

ii. $\langle 0|p|0\rangle = 0$

iii. $\langle 0|(\Delta x)^2|0\rangle = \frac{\hbar}{2m\omega_0}$

iv. $\langle 0|(\Delta p)^2|0\rangle = \frac{m\hbar\omega_0}{2}$

39. The proof of the clue is:

$$N^2 = b^\dagger b b^\dagger b = b^\dagger (1 - b^\dagger b) b = N . \quad (5.343)$$

Moreover, N is Hermitian, thus N is a projector.

a) Let $|n\rangle$ be the eigenvectors of N and n the corresponding real eigenvalues (N is Hermitian)

$$N |n\rangle = n |n\rangle . \quad (5.344)$$

Using the clue one finds that $n^2 = n$, thus the possible values of n are 0 (ground state) and 1 (excited state). Thus, the eigenvalues of \mathcal{H} are 0 and ϵ .

b) To verify the statement in the clue we calculate

$$N b^\dagger |0\rangle = b^\dagger b b^\dagger |0\rangle = b^\dagger (1 - N) |0\rangle = b^\dagger |0\rangle , \quad (5.345)$$

thus the state $b^\dagger |0\rangle$ is indeed an eigenvector of N with eigenvalue 1 (excited state). In what follows we use the notation

$$|1\rangle = b^\dagger |0\rangle . \quad (5.346)$$

Note that $|1\rangle$ is normalized since

$$\langle 1|1\rangle = \langle 0|b b^\dagger |0\rangle = \langle 0|(1 - N)|0\rangle = \langle 0|0\rangle = 1 . \quad (5.347)$$

Moreover, since $|0\rangle$ and $|1\rangle$ are eigenvectors of an Hermitian operator with different eigenvalues they must be orthogonal to each other

$$\langle 0|1\rangle = 0. \quad (5.348)$$

Using Eqs. (5.346), (5.347) and (5.348) one finds

$$\langle +|+\rangle = 2|A_+|^2, \quad (5.349)$$

$$\langle -|-\rangle = 2|A_-|^2. \quad (5.350)$$

choosing the normalization constants to be non-negative real numbers lead to

$$A_+ = A_- = \frac{1}{\sqrt{2}}. \quad (5.351)$$

c) Using $N^2 = N$ one finds

$$\begin{aligned} \exp\left(-\frac{i\mathcal{H}t}{\hbar}\right) &= 1 + \sum_{n=1}^{\infty} \frac{1}{n!} \left(-\frac{i\mathcal{H}t}{\hbar}\right)^n \\ &= 1 + N \sum_{n=1}^{\infty} \frac{1}{n!} \left(-\frac{i\epsilon t}{\hbar}\right)^n \\ &= 1 + N \left(-1 + \sum_{n=0}^{\infty} \frac{1}{n!} \left(-\frac{i\epsilon t}{\hbar}\right)^n\right) \\ &= 1 + N \left(-1 + \exp\left(-\frac{i\epsilon t}{\hbar}\right)\right). \end{aligned} \quad (5.352)$$

Thus

$$\begin{aligned} p_0(t) &= \left| \langle -| \exp\left(-\frac{i\mathcal{H}t}{\hbar}\right) |+\rangle \right|^2 \\ &= \frac{1}{4} \left| (\langle 0| - \langle 1|) \left[1 + N \left(-1 + \exp\left(-\frac{i\epsilon t}{\hbar}\right)\right) \right] (|0\rangle + |1\rangle) \right|^2 \\ &= \frac{1}{4} \left| 1 - \exp\left(-\frac{i\epsilon t}{\hbar}\right) \right|^2 \\ &= \sin^2\left(\frac{\epsilon t}{2\hbar}\right). \end{aligned} \quad (5.353)$$

40. The closure relation (5.31) can be written as

$$1 = \sum_{n,m=0}^{\infty} |n\rangle \langle m| \delta_{n,m}. \quad (5.354)$$

With the help of Eq. (5.32) together with the relation

$$\frac{1}{n!} \left(\frac{d}{d\zeta}\right)^n \zeta^m \Big|_{\zeta=0} = \delta_{n,m}, \quad (5.355)$$

which is obtained using the Taylor power expansion series of the function ζ^m , one finds that

$$\begin{aligned}
1 &= \sum_{n,m=0}^{\infty} |n\rangle \langle m| \delta_{n,m} \\
&= \sum_{n,m=0}^{\infty} \frac{1}{\sqrt{n!}\sqrt{m!}} |n\rangle \langle m| \left(\frac{d}{d\zeta} \right)^n \zeta^m \Big|_{\zeta=0} \\
&= \sum_{n,m=0}^{\infty} \frac{(a^\dagger)^n}{n!} |0\rangle \langle 0| \frac{a^m}{m!} \left(\frac{d}{d\zeta} \right)^n \zeta^m \Big|_{\zeta=0} \\
&= \left(\sum_{n=0}^{\infty} \frac{(a^\dagger)^n \left(\frac{d}{d\zeta} \right)^n}{n!} \right) |0\rangle \langle 0| \left(\sum_{m=0}^{\infty} \frac{a^m \zeta^m}{m!} \right) \Big|_{\zeta=0} \\
&= \exp \left(a^\dagger \frac{d}{d\zeta} \right) |0\rangle \langle 0| \exp(a\zeta) \Big|_{\zeta=0} .
\end{aligned} \tag{5.356}$$

Denote the normal ordering representation of the operator $|0\rangle \langle 0|$ by Z , i.e.

$$|0\rangle \langle 0| =: Z: . \tag{5.357}$$

For general functions f, g and h of the operators a and a^\dagger it is easy to show that the following holds

$$: fg: =: gf: , \tag{5.358}$$

$$: fgh: =: fhg: , \tag{5.359}$$

and

$$: f(:g:): =: fg: . \tag{5.360}$$

Thus

$$\begin{aligned}
 1 &= \exp\left(a^\dagger \frac{d}{d\zeta}\right) : Z : \exp(a\zeta) \Big|_{\zeta=0} \\
 &= : \exp\left(a^\dagger \frac{d}{d\zeta}\right) Z \exp(a\zeta) \Big|_{\zeta=0} : \\
 &= : \exp\left(a^\dagger \frac{d}{d\zeta}\right) \exp(a\zeta) Z \Big|_{\zeta=0} : \\
 &= : \sum_{n,m} \frac{\left(a^\dagger \frac{d}{d\zeta}\right)^n (a\zeta)^m}{n! m!} Z \Big|_{\zeta=0} : \\
 &= : \sum_{n,m} (a^\dagger)^n \underbrace{\frac{\left(\frac{d}{d\zeta}\right)^n}{n!} \zeta^m \Big|_{\zeta=0}}_{\delta_{n,m}} \frac{a^m}{m!} Z : \\
 &= : \exp(a^\dagger a) Z : \\
 &= : \exp(a^\dagger a) (: Z :) : ,
 \end{aligned} \tag{5.361}$$

and therefore

$$|0\rangle \langle 0| = : \exp(-a^\dagger a) : . \tag{5.362}$$

Using again Eq. (5.32) one finds that

$$P_n = |n\rangle \langle n| = \frac{1}{n!} : (a^\dagger)^n \exp(-a^\dagger a) a^n : . \tag{5.363}$$

Alternatively, the relation (5.362) can be derived using the binomial theorem, which can be expressed as

$$(x + y)^n = \sum_{n'=0}^n \binom{n}{n'} x^{n-n'} y^{n'} , \tag{5.364}$$

the relation

$$: \exp(-a^\dagger a) : = 1 - a^\dagger a + \frac{a^\dagger a^\dagger a a}{2!} - \frac{a^\dagger a^\dagger a^\dagger a a a}{3!} + \dots , \tag{5.365}$$

and Eqs. (5.28) and (5.29), which together yield for $n \geq 1$

$$\begin{aligned}
 : \exp(-a^\dagger a) : |n\rangle &= \left(\sum_{n'=0}^n \frac{n!}{n'! (n-n')!} (-1)^{n'} \right) |n\rangle \\
 &= \left(\sum_{n'=0}^n \binom{n}{n'} 1^{n-n'} (-1)^{n'} \right) |n\rangle ,
 \end{aligned} \tag{5.366}$$

hence

$$: \exp(-a^\dagger a) : |n\rangle = \delta_{n,0} |n\rangle , \quad (5.367)$$

in agreement with Eq. (5.362).

41. The Hamiltonian \mathcal{H} , which is given by

$$\mathcal{H} = \frac{p^2}{2m} + \frac{m\omega^2 x^2}{2} + xf(t) , \quad (5.368)$$

can be expressed in terms of the annihilation a and creation a^\dagger operators [see Eqs. (5.11) and (5.12)] as

$$\mathcal{H} = \hbar\omega \left(a^\dagger a + \frac{1}{2} \right) + f(t) \sqrt{\frac{\hbar}{2m\omega}} (a + a^\dagger) . \quad (5.369)$$

The Heisenberg equation of motion for the operator a is given by [see Eq. (4.37)]

$$\frac{da}{dt} = -i\omega a - i\sqrt{\frac{1}{2m\hbar\omega}} f(t) . \quad (5.370)$$

The solution of this first order differential equation is given by

$$a(t) = e^{-i\omega(t-t_0)} a(t_0) - i\sqrt{\frac{1}{2m\hbar\omega}} \int_{t_0}^t dt' e^{-i\omega(t-t')} f(t') , \quad (5.371)$$

where the initial time t_0 will be taken below to be $-\infty$. The Heisenberg operator $a^\dagger(t)$ is found from the Hermitian conjugate of the last result. Let $P_n(t)$ be the Heisenberg representation of the projector $|n\rangle\langle n|$. The probability $p_n(t)$ to find the oscillator in the number state $|n\rangle$ at time t is given by

$$p_n(t) = \langle 0 | P_n(t) | 0 \rangle . \quad (5.372)$$

To evaluate $p_n(t)$ it is convenient to employ the normal ordering representation of the operator P_n (5.110). In normal ordering the first term of Eq. (5.371), which is proportional to $a(t_0)$ does not contribute to $p_n(t)$ since $a(t_0)|0\rangle = 0$ and also $\langle 0|a^\dagger(t_0) = 0$. To evaluate $p_n = p_n(t \rightarrow \infty)$ the integral in the second term of Eq. (5.371) is evaluate from $t_0 = -\infty$ to $t = +\infty$. Thus one finds that

$$p_n = \frac{e^{-\mu} \mu^n}{n!} , \quad (5.373)$$

where

$$\mu = \frac{1}{2m\hbar\omega} \left| \int_{-\infty}^{\infty} dt' e^{i\omega t'} f(t') \right|^2 . \quad (5.374)$$

42. As can be seen from the definition of \mathcal{P} , the following holds

$$\begin{aligned}\langle x' | \mathcal{P} | \psi \rangle &= \int_{-\infty}^{\infty} dx'' \langle x' | x'' \rangle \langle -x'' | \psi \rangle \\ &= \langle -x' | \psi \rangle ,\end{aligned}\tag{5.375}$$

thus the wave function of $\mathcal{P} | \psi \rangle$ is $\psi(-x')$ given that the wave function of $| \psi \rangle$ is $\psi(x')$. For the wavefunctions $\psi_n(x') = \langle x' | n \rangle$ of the number states $| n \rangle$, which satisfy $N | n \rangle = n | n \rangle$, the following holds

$$\psi_n(-x') = \begin{cases} -\psi_n(x') & n \text{ odd} \\ \psi_n(x') & n \text{ even} \end{cases} ,\tag{5.376}$$

thus

$$\mathcal{P} | n \rangle = \begin{cases} -| n \rangle & n \text{ odd} \\ | n \rangle & n \text{ even} \end{cases} ,\tag{5.377}$$

or $\mathcal{P} | n \rangle = (-1)^n | n \rangle$, and consequently the parity operator \mathcal{P} can be expressed as a function of N

$$\mathcal{P} = e^{i\pi N} .\tag{5.378}$$

43. Using Eqs. (5.31), (5.32) and (5.362) together with the relation

$$a^\dagger a | n \rangle = n | n \rangle ,\tag{5.379}$$

yields

$$\begin{aligned}e^{\lambda a^\dagger a} &= \sum_{n=0}^{\infty} e^{\lambda n} | n \rangle \langle n | \\ &= \sum_{n=0}^{\infty} e^{\lambda n} \frac{(a^\dagger)^n}{\sqrt{n!}} | 0 \rangle \langle 0 | \frac{a^n}{\sqrt{n!}} \\ &= \sum_{n=0}^{\infty} \frac{e^{\lambda n}}{n!} (a^\dagger)^n : \exp(-a^\dagger a) : a^n \\ &= \sum_{n=0}^{\infty} \frac{e^{\lambda n}}{n!} : (a^\dagger)^n \exp(-a^\dagger a) a^n : \\ &=: \sum_{n=0}^{\infty} \frac{e^{\lambda n}}{n!} (a^\dagger a)^n \exp(-a^\dagger a) : \\ &=: \exp(e^\lambda a^\dagger a) \exp(-a^\dagger a) : ,\end{aligned}\tag{5.380}$$

thus

$$e^{\lambda a^\dagger a} =: \exp[(e^\lambda - 1) a^\dagger a] : .\tag{5.381}$$

44. The following holds [see Eq. (5.31)]

$$|x'\rangle = \sum_{n=0}^{\infty} |n\rangle \langle n | x'\rangle , \quad (5.382)$$

where

$$|n\rangle = \frac{(a^\dagger)^n}{\sqrt{n!}} |0\rangle , \quad (5.383)$$

thus with the help of Eq. (5.134) and the generating function of Hermite polynomials (5.56) one finds that (note that $\langle x' | n\rangle$ is real)

$$\begin{aligned} |x'\rangle &= \frac{\exp\left(-\frac{x'^2}{2x_0^2}\right)}{\pi^{1/4}x_0^{1/2}} \sum_{n=0}^{\infty} \frac{H_n\left(\frac{x'}{x_0}\right)}{\sqrt{2^n n!}} \frac{(a^\dagger)^n}{\sqrt{n!}} |0\rangle \\ &= \frac{\exp\left(-\frac{x'^2}{2x_0^2} + \sqrt{2}\frac{x'}{x_0}a^\dagger - \frac{a^{\dagger 2}}{2}\right)}{\pi^{1/4}x_0^{1/2}} |0\rangle . \end{aligned} \quad (5.384)$$

45. Using the relation $x |x'\rangle = x' |x'\rangle$ and Eq. (3.32) one finds that

$$\exp(kx^2) = \int_{-\infty}^{\infty} dx' e^{kx'^2} |x'\rangle \langle x'| . \quad (5.385)$$

Eqs. (5.362) and (5.113) yield

$$|x'\rangle \langle x'| = \frac{1}{\sqrt{\pi}x_0} : e^{-(X'-X)^2} : , \quad (5.386)$$

where

$$X = \frac{a + a^\dagger}{\sqrt{2}} = \frac{x}{x_0} , \quad (5.387)$$

and where

$$X' = \frac{x'}{x_0} . \quad (5.388)$$

Thus

$$\begin{aligned} \exp(kx^2) &= \frac{1}{\sqrt{\pi}} \int_{-\infty}^{\infty} dX' : e^{-(X'-X)^2 + KX'^2} : \\ &= \frac{1}{\sqrt{\pi}} \int_{-\infty}^{\infty} dX' : e^{-(1-K)X'^2 + 2X'X - X^2} : , \end{aligned} \quad (5.389)$$

where $K = kx_0^2$. With the help of the identity (5.149) this becomes

$$\exp\left(\frac{Kx^2}{x_0^2}\right) = \frac{1}{\sqrt{1-K}} : \exp\left(\frac{K}{1-K} \frac{x^2}{x_0^2}\right) : . \quad (5.390)$$

Using the notation

$$\kappa = \frac{K}{1-K} , \quad (5.391)$$

the results can be also expressed as

$$\frac{1}{\sqrt{1+\kappa}} \exp\left(\frac{\kappa}{1+\kappa} \frac{x^2}{x_0^2}\right) =: \exp\left(\kappa \frac{x^2}{x_0^2}\right) : . \quad (5.392)$$

46. The orthogonality between number states yields according to Eq. (5.134)

$$\begin{aligned} \langle m | n \rangle &= \int_{-\infty}^{\infty} dx' \frac{\exp\left(-\frac{x'^2}{x_0^2}\right) H_m\left(\frac{x'}{x_0}\right) H_n\left(\frac{x'}{x_0}\right)}{\sqrt{\pi 2^m m! 2^n n!} x_0} \\ &= \int_{-\infty}^{\infty} dX' \frac{\exp(-X'^2) H_m(X') H_n(X')}{\sqrt{\pi 2^m m! 2^n n!}} \\ &= \delta_{nm} . \end{aligned} \quad (5.393)$$

Multiplying Eq. (5.56) by the factor $e^{-z^2} H_m(z)$

$$e^{-(z-t)^2} H_m(z) = e^{-z^2} H_m(z) \sum_{n=0}^{\infty} H_n(z) \frac{t^n}{n!} , \quad (5.394)$$

and integrating over z

$$\begin{aligned} &\int_{-\infty}^{\infty} dz e^{-(z-t)^2} H_m(z) \\ &= \sum_{n=0}^{\infty} \frac{t^n}{n!} \int_{-\infty}^{\infty} dz e^{-z^2} H_m(z) H_n(z) , \end{aligned} \quad (5.395)$$

yields with the help of Eq. (5.393)

$$\int_{-\infty}^{\infty} dz e^{-(z-t)^2} H_m(z) = (2t)^m \sqrt{\pi} . \quad (5.396)$$

The relations $x|x'\rangle = x'|x'\rangle$, $X = (a + a^\dagger)/\sqrt{2} = x/x_0$ together with Eq. (5.386) yield

$$\begin{aligned} H_n(X) &= \int_{-\infty}^{\infty} dx' H_n\left(\frac{x'}{x_0}\right) |x'\rangle \langle x'| \\ &= \frac{1}{\sqrt{\pi}} : \int_{-\infty}^{\infty} dX' e^{-(X'-X)^2} H_n(X') : , \end{aligned} \quad (5.397)$$

thus, with the help of Eq. (5.396) one finds that

$$H_n(X) =: (2X)^n : . \quad (5.398)$$

The last result together with the identity

$$\frac{dH_n}{dX'} = 2nH_{n-1}(X') , \quad (5.399)$$

yields

$$\begin{aligned} \frac{d}{dX} : X^n : &= \frac{1}{2^n} \frac{dH_n(X)}{dX} \\ &= n \frac{H_{n-1}(X)}{2^{n-1}} \\ &= n : X^{n-1} : , \end{aligned} \quad (5.400)$$

thus

$$\frac{d}{dX} : X^n : =: \frac{d}{dX} X^n : . \quad (5.401)$$

Thus, for a general smooth function $F(X)$ of the operator X the following holds

$$\frac{d}{dX} : F(X) : =: \frac{dF}{dX} : . \quad (5.402)$$

47. The following holds [see Eqs. (5.28) and (5.29)]

$$\begin{aligned} S|n_1\rangle &= \sum_{k=0}^{\infty} \frac{(e^\lambda - 1)^k}{k!} a^{\dagger k} a^k |n_1\rangle \\ &= \sum_{k=0}^{n_1} \frac{(e^\lambda - 1)^k}{k!} \frac{n_1!}{(n_1 - k)!} |n_1\rangle , \end{aligned} \quad (5.403)$$

thus, with the help of the binomial theorem one finds that

$$S |n_1\rangle = e^{\lambda n_1} |n_1\rangle , \quad (5.404)$$

hence

$$\langle n_2 | S |n_1\rangle = e^{\lambda n_1} \delta_{n_1, n_2}. \quad (5.405)$$

Alternatively, the same result can be easily obtained with the help of Eq.(5.112), according to which

$$S = e^{\lambda a^\dagger a} . \quad (5.406)$$

48. Initially, the system is in a coherent state given by Eq. (5.42)

$$|\psi(t=0)\rangle = |\alpha\rangle_c = e^{-\frac{|\alpha|^2}{2}} \sum_{n=0}^{\infty} \frac{\alpha^n}{\sqrt{n!}} |n\rangle . \quad (5.407)$$

The notation $|\alpha\rangle_c$ is used to label coherent states satisfying $a|\alpha\rangle_c = \alpha|\alpha\rangle_c$.

a) Since $a^\dagger a$ commutes with $(a^\dagger a)^k$, the time evolution operator is given by [see Eq. (4.9)]

$$u(t) = \exp\left(-\frac{i\mathcal{H}t}{\hbar}\right) = e^{-i\omega_1(a^\dagger a)^k t} e^{-i\omega a^\dagger a t} , \quad (5.408)$$

thus

$$\begin{aligned} |\psi(t)\rangle &= u(t) |\psi(t=0)\rangle \\ &= e^{-i\omega_1(a^\dagger a)^k t} e^{-i\omega a^\dagger a t} e^{-\frac{|\alpha|^2}{2}} \sum_{n=0}^{\infty} \frac{\alpha^n}{\sqrt{n!}} |n\rangle \\ &= e^{-i\omega_1(a^\dagger a)^k t} e^{-\frac{|\alpha|^2}{2}} \sum_{n=0}^{\infty} \frac{(\alpha e^{-i\omega t})^n}{\sqrt{n!}} |n\rangle \\ &= e^{-\frac{|\alpha|^2}{2}} \sum_{n=0}^{\infty} \frac{(\alpha e^{-i\omega t})^n}{\sqrt{n!}} e^{-i\phi_n} |n\rangle , \end{aligned} \quad (5.409)$$

where

$$\phi_n = \omega_1 t n^k . \quad (5.410)$$

b) At time $t = 2\pi/\omega_1$ the phase factor ϕ_n is given by $\phi_n = 2\pi n^k$, thus

$$e^{-i\phi_n} = 1 , \quad (5.411)$$

and therefore

$$\left| \psi\left(\frac{2\pi}{\omega_1}\right) \right\rangle = \left| \alpha e^{-\frac{2\pi i\omega}{\omega_1}} \right\rangle_c . \quad (5.412)$$

- c) At time $t = \pi/\omega_1$ the phase factor ϕ_n is given by $\phi_n = \pi n^k$. Using the fact that

$$\text{mod}(n^k, 2) = \begin{cases} 0 & n \text{ is even} \\ 1 & n \text{ is odd} \end{cases}, \quad (5.413)$$

one has

$$e^{-i\phi_n} = (-1)^n, \quad (5.414)$$

and therefore

$$\begin{aligned} \left| \psi \left(\frac{\pi}{\omega_1} \right) \right\rangle &= e^{-\frac{|\alpha|^2}{2}} \sum_{n=0}^{\infty} \frac{(\alpha e^{-\frac{\pi i \omega}{\omega_1}})^n}{\sqrt{n!}} (-1)^n |n\rangle \\ &= \left| -\alpha e^{-\frac{\pi i \omega}{\omega_1}} \right\rangle_c. \end{aligned} \quad (5.415)$$

- d) At time $t = \pi/2\omega_1$ the phase factor ϕ_n is given by $\phi_n = (\pi/2)n^k$. For the case where k is even one has

$$\text{mod}(n^k, 4) = \begin{cases} 0 & n \text{ is even} \\ 1 & n \text{ is odd} \end{cases}, \quad (5.416)$$

thus

$$e^{-i\phi_n} = \begin{cases} 1 & n \text{ is even} \\ -i & n \text{ is odd} \end{cases}, \quad (5.417)$$

and therefore

$$\left| \psi \left(\frac{\pi}{2\omega_1} \right) \right\rangle = e^{-\frac{|\alpha|^2}{2}} \sum_{n=0}^{\infty} \frac{(\alpha e^{-\frac{\pi i \omega}{2\omega_1}})^n}{\sqrt{n!}} e^{-i\phi_n} |n\rangle. \quad (5.418)$$

This state can be expressed as a superposition of two coherent states

$$\left| \psi \left(\frac{\pi}{2\omega_1} \right) \right\rangle = \frac{1}{\sqrt{2}} \left(e^{-\frac{i\pi}{4}} \left| \alpha e^{-\frac{\pi i \omega}{2\omega_1}} \right\rangle_c + e^{\frac{i\pi}{4}} \left| -\alpha e^{-\frac{\pi i \omega}{2\omega_1}} \right\rangle_c \right). \quad (5.419)$$

49. Let $\{\lambda_n\}$ be the set of eigenvalues of A . Clearly A is Hermitian, namely $A^\dagger = A$, thus the eigenvalues λ_n are expected to be real. Since the trace of an operator is basis independent, the following must hold

$$\text{Tr}(A) = \sum_n \lambda_n, \quad (5.420)$$

and

$$\text{Tr}(A^2) = \sum_n \lambda_n^2. \quad (5.421)$$

On the other hand, with the help of Eq. (2.181) one finds that

$$\text{Tr}(A) = \text{Tr}(|\alpha\rangle\langle\alpha|) - \text{Tr}(|\beta\rangle\langle\beta|) = 0, \quad (5.422)$$

and

$$\begin{aligned} \text{Tr}(A^2) &= \text{Tr}(|\alpha\rangle\langle\alpha|\alpha\rangle\langle\alpha|) + \text{Tr}(|\beta\rangle\langle\beta|\beta\rangle\langle\beta|) \\ &\quad - \text{Tr}(|\alpha\rangle\langle\alpha|\beta\rangle\langle\beta|) - \text{Tr}(|\beta\rangle\langle\beta|\alpha\rangle\langle\alpha|) \\ &= 2 - \langle\alpha|\beta\rangle\text{Tr}(|\alpha\rangle\langle\beta|) - \langle\beta|\alpha\rangle\text{Tr}(|\beta\rangle\langle\alpha|) \\ &= 2\left(1 - |\langle\alpha|\beta\rangle|^2\right). \end{aligned} \quad (5.423)$$

Clearly, A cannot have more than two nonzero eigenvalues, since the dimensionality of the subspace spanned by the vectors $\{|\alpha\rangle, |\beta\rangle\}$ is at most 2, and therefore A has three eigenvalues 0, λ_+ and λ_- , where [see Eq. (5.252)]

$$\lambda_{\pm} = \pm\sqrt{1 - |\langle\alpha|\beta\rangle|^2} = \pm\sqrt{1 - e^{-|\alpha-\beta|^2}}. \quad (5.424)$$

6. Angular Momentum

Consider a point particle moving in three dimensional space. The *orbital* angular momentum \mathbf{L} is given by

$$\mathbf{L} = \mathbf{r} \times \mathbf{p} = \det \begin{pmatrix} \hat{\mathbf{x}} & \hat{\mathbf{y}} & \hat{\mathbf{z}} \\ x & y & z \\ p_x & p_y & p_z \end{pmatrix},$$

where $\mathbf{r} = (x, y, z)$ is the position vector and where $\mathbf{p} = (p_x, p_y, p_z)$ is the momentum vector. In classical physics the following holds:

Claim.

$$\{L_i, L_j\} = \varepsilon_{ijk} L_k, \quad (6.1)$$

where

$$\varepsilon_{ijk} = \begin{cases} 0 & i, j, k \text{ are not all different} \\ 1 & i, j, k \text{ is an even permutation of } x, y, z \\ -1 & i, j, k \text{ is an odd permutation of } x, y, z \end{cases}. \quad (6.2)$$

Proof. Clearly, Eq. (6.1) holds for the case $i = j$. Using Eq. (1.48), which reads

$$\{x_i, p_j\} = \delta_{ij}, \quad (6.3)$$

one has

$$\begin{aligned} \{L_x, L_y\} &= \{yp_z - zp_y, zp_x - xp_z\} \\ &= \{yp_z, zp_x\} + \{zp_y, xp_z\} \\ &= y\{p_z, z\}p_x + x\{z, p_z\}p_y \\ &= -yp_x + xp_y \\ &= L_z. \end{aligned} \quad (6.4)$$

In a similar way one finds that $\{L_y, L_z\} = L_x$ and $\{L_z, L_x\} = L_y$. These results together with Eq. (1.49) complete the proof.

Using the rule (4.41) $\{, \} \rightarrow (1/i\hbar)[,]$ one concludes that in quantum mechanics the following holds:

$$[L_i, L_j] = i\hbar\varepsilon_{ijk} L_k. \quad (6.5)$$

6.1 Angular Momentum and Rotation

We have seen before that the unitary operator $u(t, t_0)$ is the generator of time evolution [see Eq. (4.4)]. Similarly, we have seen that the unitary operator

$$J(\Delta) = \exp\left(-\frac{i\Delta \cdot \mathbf{p}}{\hbar}\right) \quad (6.6)$$

[see Eq. (3.73)] is the generator of linear translations:

$$J(\Delta) |\mathbf{r}'\rangle = |\mathbf{r}' + \Delta\rangle . \quad (6.7)$$

Below we will see that one can define a unitary operator that generates rotations.

Exercise 6.1.1. Show that

$$D_{\hat{\mathbf{z}}}^\dagger(\phi) \begin{pmatrix} x \\ y \\ z \end{pmatrix} D_{\hat{\mathbf{z}}}(\phi) = R_{\hat{\mathbf{z}}} \begin{pmatrix} x \\ y \\ z \end{pmatrix} , \quad (6.8)$$

where

$$D_{\hat{\mathbf{z}}}(\phi) = \exp\left(-\frac{i\phi L_z}{\hbar}\right) , \quad (6.9)$$

and where

$$R_{\hat{\mathbf{z}}} = \begin{pmatrix} \cos \phi & -\sin \phi & 0 \\ \sin \phi & \cos \phi & 0 \\ 0 & 0 & 1 \end{pmatrix} . \quad (6.10)$$

Solution 6.1.1. Equation (6.8) is made of 3 identities:

$$D_{\hat{\mathbf{z}}}^\dagger(\phi) x D_{\hat{\mathbf{z}}}(\phi) = x \cos \phi - y \sin \phi , \quad (6.11)$$

$$D_{\hat{\mathbf{z}}}^\dagger(\phi) y D_{\hat{\mathbf{z}}}(\phi) = x \sin \phi + y \cos \phi , \quad (6.12)$$

$$D_{\hat{\mathbf{z}}}^\dagger(\phi) z D_{\hat{\mathbf{z}}}(\phi) = z . \quad (6.13)$$

As an example, we prove below the first one. Using the identity (2.182), which is given by

$$e^L A e^{-L} = A + [L, A] + \frac{1}{2!} [L, [L, A]] + \frac{1}{3!} [L, [L, [L, A]]] + \dots , \quad (6.14)$$

one has

$$\begin{aligned} & D_{\hat{\mathbf{z}}}^\dagger(\phi) x D_{\hat{\mathbf{z}}}(\phi) \\ &= x + \frac{i\phi}{\hbar} [L_z, x] + \frac{1}{2!} \left(\frac{i\phi}{\hbar}\right)^2 [L_z, [L_z, x]] + \frac{1}{3!} \left(\frac{i\phi}{\hbar}\right)^3 [L_z, [L_z, [L_z, x]]] + \dots . \end{aligned} \quad (6.15)$$

Furthermore with the help of

$$L_z = xp_y - yp_x, \quad (6.16)$$

$$[x_i, p_j] = i\hbar\delta_{ij}, \quad (6.17)$$

one finds that

$$\begin{aligned} [L_z, x] &= -y [p_x, x] = i\hbar y, \\ [L_z, [L_z, x]] &= i\hbar x [p_y, y] = -(i\hbar)^2 x, \\ [L_z, [L_z, [L_z, x]]] &= -(i\hbar)^2 [L_z, x] = -(i\hbar)^3 y, \\ [L_z, [L_z, [L_z, [L_z, x]]]] &= (i\hbar)^4 x, \\ &\vdots \end{aligned} \quad (6.18)$$

thus

$$\begin{aligned} D_{\hat{\mathbf{z}}}^\dagger(\phi) x D_{\hat{\mathbf{z}}}(\phi) &= x \left(1 - \frac{\phi^2}{2!} + \frac{\phi^4}{4!} + \dots \right) - y \left(\phi - \frac{\phi^3}{3!} + \dots \right) \\ &= x \cos \phi - y \sin \phi. \end{aligned} \quad (6.19)$$

The other 2 identities in Eq. (6.8) can be proven in a similar way.

The matrix $R_{\hat{\mathbf{z}}}$ [see Eq. (6.10)] represents a geometrical rotation around the z axis with angle ϕ . Therefore, in view of the above result, we refer to the operator $D_{\hat{\mathbf{z}}}(\phi)$ as the generator of rotation around the z axis with angle ϕ . It is straightforward to generalize the above results and to show that rotation around an arbitrary unit vector $\hat{\mathbf{n}}$ axis with angle ϕ is given by

$$D_{\hat{\mathbf{n}}}(\phi) = \exp\left(-\frac{i\phi\mathbf{L} \cdot \hat{\mathbf{n}}}{\hbar}\right). \quad (6.20)$$

In view of Eq. (3.73), it can be said that linear momentum \mathbf{p} generates translations. Similarly, in view of the above equation (6.20), angular momentum \mathbf{L} generates rotation. However, there is an important distinction between these two types of geometrical transformations. On one hand, according to Eq. (3.7) the observables p_x , p_y and p_z commute with each other, and consequently translation operators with different translation vectors commute

$$[J(\Delta_1), J(\Delta_2)] = 0. \quad (6.21)$$

On the other hand, as can be seen from Eq. (6.5), different components of \mathbf{L} do not commute and therefore rotation operators $D_{\hat{\mathbf{n}}}(\phi)$ with different rotations axes $\hat{\mathbf{n}}$ need not commute. Both the above results, which were obtained from commutation relations between quantum operators, demonstrate two well known geometrical facts: (i) different linear translations commute, whereas (ii) generally, different rotations do not commute.

6.2 General Angular Momentum

Elementary particles carry angular momentum in two different forms. The first one is the above discussed orbital angular momentum, which is commonly labeled as \mathbf{L} . This contribution $\mathbf{L} = \mathbf{r} \times \mathbf{p}$ has a classical analogue, which was employed above to derive the commutation relations (6.5) from the corresponding Poisson's brackets relations. The other form of angular momentum is spin, which is commonly labeled as \mathbf{S} . Contrary to the orbital angular momentum, the spin does not have any classical analogue. In a general discussion on angular momentum in quantum mechanics the label \mathbf{J} is commonly employed.

L - orbital angular momentum

S - spin angular momentum

J - general angular momentum

In the discussion below we derive some properties of angular momentum in quantum mechanics, where our only assumption is that the components of the angular momentum vector of operators $\mathbf{J} = (J_x, J_y, J_z)$ obey the following commutation relations

$$[J_i, J_j] = i\hbar\varepsilon_{ijk}J_k . \quad (6.22)$$

Namely, we assume that Eq. (6.5), which was obtained from the corresponding Poisson's brackets relations for the case of *orbital* angular momentum holds for general angular momentum.

6.3 Simultaneous Diagonalization of \mathbf{J}^2 and J_z

As we have seen in chapter 2, commuting operators can be simultaneously diagonalized. In this section we seek such simultaneous diagonalization of the operators \mathbf{J}^2 and J_z , where

$$\mathbf{J}^2 = J_x^2 + J_y^2 + J_z^2 . \quad (6.23)$$

As is shown by the claim below, these operators commute.

Claim. The following holds

$$[\mathbf{J}^2, J_x] = [\mathbf{J}^2, J_y] = [\mathbf{J}^2, J_z] = 0 . \quad (6.24)$$

Proof. Using Eq. (6.22) one finds that

$$\begin{aligned} [\mathbf{J}^2, J_z] &= [J_x^2, J_z] + [J_y^2, J_z] \\ &= i\hbar(-J_xJ_y - J_yJ_x + J_yJ_x + J_xJ_y) = 0 . \end{aligned} \quad (6.25)$$

In a similar way one can show that $[\mathbf{J}^2, J_x] = [\mathbf{J}^2, J_y] = 0$.

The common eigenvectors of the operators \mathbf{J}^2 and J_z are labeled as $|a, b\rangle$, and the corresponding eigenvalues are labeled as $a\hbar^2$ and $b\hbar$ respectively

$$\mathbf{J}^2 |a, b\rangle = a\hbar^2 |a, b\rangle , \quad (6.26)$$

$$J_z |a, b\rangle = b\hbar |a, b\rangle . \quad (6.27)$$

Recall that we have shown in chapter 5 for the case of harmonic oscillator that the ket-vectors $a|n\rangle$ and $a^\dagger|n\rangle$ are eigenvectors of the number operator N provided that $|n\rangle$ is an eigenvector of N . Somewhat similar claim can be made regarding the current problem under consideration of simultaneous diagonalization of \mathbf{J}^2 and J_z :

Theorem 6.3.1. *Let $|a, b\rangle$ be a normalized simultaneous eigenvector of the operators \mathbf{J}^2 and J_z with eigenvalues $\hbar^2 a$ and $\hbar b$ respectively, i.e.*

$$\mathbf{J}^2 |a, b\rangle = a\hbar^2 |a, b\rangle , \quad (6.28)$$

$$J_z |a, b\rangle = b\hbar |a, b\rangle , \quad (6.29)$$

$$\langle a, b | a, b\rangle = 1 . \quad (6.30)$$

Then (i) the vector

$$|a, b+1\rangle \equiv \hbar^{-1} [a - b(b+1)]^{-1/2} J_+ |a, b\rangle \quad (6.31)$$

where

$$J_+ = J_x + iJ_y , \quad (6.32)$$

is a normalized simultaneous eigenvector of the operators \mathbf{J}^2 and J_z with eigenvalues $\hbar^2 a$ and $\hbar(b+1)$ respectively, namely

$$\mathbf{J}^2 |a, b+1\rangle = a\hbar^2 |a, b+1\rangle , \quad (6.33)$$

$$J_z |a, b+1\rangle = (b+1)\hbar |a, b+1\rangle . \quad (6.34)$$

(ii) The vector

$$|a, b-1\rangle \equiv \hbar^{-1} [a - b(b-1)]^{-1/2} J_- |a, b\rangle \quad (6.35)$$

where

$$J_- = J_x - iJ_y , \quad (6.36)$$

is a normalized simultaneous eigenvector of the operators \mathbf{J}^2 and J_z with eigenvalues $\hbar^2 a$ and $\hbar(b-1)$ respectively, namely

$$\mathbf{J}^2 |a, b-1\rangle = a\hbar^2 |a, b-1\rangle , \quad (6.37)$$

$$J_z |a, b-1\rangle = (b-1)\hbar |a, b-1\rangle . \quad (6.38)$$

Proof. The following holds

$$\mathbf{J}^2 (J_{\pm} |a, b\rangle) = \left(\underbrace{[\mathbf{J}^2, J_{\pm}]}_0 + J_{\pm} \mathbf{J}^2 \right) |a, b\rangle = a \hbar^2 (J_{\pm} |a, b\rangle) . \quad (6.39)$$

Similarly

$$J_z (J_{\pm} |a, b\rangle) = ([J_z, J_{\pm}] + J_{\pm} J_z) |a, b\rangle , \quad (6.40)$$

where

$$[J_z, J_{\pm}] = [J_z, J_x \pm iJ_y] = \hbar (iJ_y \pm J_x) = \pm \hbar J_{\pm} , \quad (6.41)$$

thus

$$J_z (J_{\pm} |a, b\rangle) = (b \pm 1) \hbar (J_{\pm} |a, b\rangle) . \quad (6.42)$$

Using the following relations

$$\begin{aligned} J_+^{\dagger} J_+ &= J_- J_+ \\ &= (J_x - iJ_y) (J_x + iJ_y) \\ &= J_x^2 + J_y^2 + i[J_x, J_y] \\ &= \mathbf{J}^2 - J_z^2 - \hbar J_z , \end{aligned} \quad (6.43)$$

$$\begin{aligned} J_-^{\dagger} J_- &= J_+ J_- \\ &= (J_x + iJ_y) (J_x - iJ_y) \\ &= J_x^2 + J_y^2 + i[J_y, J_x] \\ &= \mathbf{J}^2 - J_z^2 + \hbar J_z , \end{aligned} \quad (6.44)$$

one finds that

$$\begin{aligned} \langle a, b | J_+^{\dagger} J_+ |a, b\rangle &= \langle a, b | \mathbf{J}^2 |a, b\rangle - \langle a, b | J_z (J_z + \hbar) |a, b\rangle \\ &= \hbar^2 [a - b(b + 1)] , \end{aligned} \quad (6.45)$$

and

$$\begin{aligned} \langle a, b | J_-^{\dagger} J_- |a, b\rangle &= \langle a, b | \mathbf{J}^2 |a, b\rangle - \langle a, b | J_z (J_z - \hbar) |a, b\rangle \\ &= \hbar^2 [a - b(b - 1)] . \end{aligned} \quad (6.46)$$

Thus the states $|a, b + 1\rangle$ and $|a, b - 1\rangle$ are both normalized.

What are the possible values of b ? Recall that we have shown in chapter 5 for the case of harmonic oscillator that the eigenvalues of the number operator N must be nonnegative since the operator N is positive-definite. Below we employ a similar approach to show that:

Claim. $b^2 \leq a$

Proof. Both J_x^2 and J_y^2 are positive-definite, therefore

$$\langle a, b | J_x^2 + J_y^2 | a, b \rangle \geq 0 . \quad (6.47)$$

On the other hand, $J_x^2 + J_y^2 = \mathbf{J}^2 - J_z^2$, therefore $a - b^2 \geq 0$.

As we did in chapter 5 for the case of the possible eigenvalues n of the number operator N , also in the present case the requirement $b^2 \leq a$ restricts the possible values that b can take:

Claim. For a given value of a the possible values of b are $\{-b_{\max}, -b_{\max} + 1, \dots, b_{\max} - 1, b_{\max}\}$ where $a = b_{\max}(b_{\max} + 1)$. Moreover, the possible values of b_{\max} are $0, 1/2, 1, 3/2, 2, \dots$.

Proof. There must be a maximum value b_{\max} for which

$$J_+ |a, b_{\max}\rangle = 0 . \quad (6.48)$$

Thus, also

$$J_+^\dagger J_+ |a, b_{\max}\rangle = 0 \quad (6.49)$$

holds. With the help of Eq. (6.43) this can be written as

$$(\mathbf{J}^2 - J_z^2 - \hbar J_z) |a, b_{\max}\rangle = [a - b_{\max}(b_{\max} + 1)] \hbar^2 |a, b_{\max}\rangle = 0 . \quad (6.50)$$

Since $|a, b_{\max}\rangle \neq 0$ one has

$$a - b_{\max}(b_{\max} + 1) = 0 , \quad (6.51)$$

or

$$a = b_{\max}(b_{\max} + 1) . \quad (6.52)$$

In a similar way with the help of Eq. (6.44) one can show that there exists a minimum value b_{\min} for which

$$a = b_{\min}(b_{\min} - 1) . \quad (6.53)$$

From the last two equations one finds that

$$b_{\max}(b_{\max} + 1) = b_{\min}(b_{\min} - 1) , \quad (6.54)$$

or

$$(b_{\max} + b_{\min})(b_{\max} - b_{\min} + 1) = 0 . \quad (6.55)$$

Thus, since $b_{\max} - b_{\min} + 1 > 0$ one finds that

$$b_{\min} = -b_{\max} . \quad (6.56)$$

The formal solutions of Eqs. (6.52) and (6.53) are given by

$$b_{\max} = -\frac{1}{2} \pm \frac{1}{2} \sqrt{1 + 4a} , \quad (6.57)$$

and

$$b_{\min} = \frac{1}{2} \mp \frac{1}{2} \sqrt{1 + 4a} . \quad (6.58)$$

Furthermore, a is an eigenvalue of a positive-definite operator \mathbf{J}^2 , therefore $a \geq 0$. Consequently, the only possible solutions for which $b_{\max} \geq b_{\min}$ are

$$b_{\max} = -\frac{1}{2} + \frac{1}{2} \sqrt{1 + 4a} \geq 0 , \quad (6.59)$$

and

$$b_{\min} = \frac{1}{2} - \frac{1}{2} \sqrt{1 + 4a} = -b_{\max} \leq 0 . \quad (6.60)$$

That is, for a given value of a , both b_{\max} and b_{\min} are uniquely determined. The value b_{\min} is obtained by successively applying the operator J_- to the state $|a, b_{\max}\rangle$ an integer number of times, and therefore $b_{\max} - b_{\min} = 2b_{\max}$ must be an integer. Consequently, the possible values of b_{\max} are $0, 1/2, 1, 3/2, \dots$.

We now change the notation $|a, b\rangle$ for the simultaneous eigenvectors to the more common notation $|j, m\rangle$, where

$$j = b_{\max} , \quad (6.61)$$

$$m = b . \quad (6.62)$$

Our results can be summarized by the following relations

$$\mathbf{J}^2 |j, m\rangle = j(j+1) \hbar^2 |j, m\rangle , \quad (6.63)$$

$$J_z |j, m\rangle = m \hbar |j, m\rangle , \quad (6.64)$$

$$J_+ |j, m\rangle = \sqrt{j(j+1) - m(m+1)} \hbar |j, m+1\rangle , \quad (6.65)$$

$$J_- |j, m\rangle = \sqrt{j(j+1) - m(m-1)} \hbar |j, m-1\rangle , \quad (6.66)$$

where the possible values j can take are

$$j = 0, \frac{1}{2}, 1, \frac{3}{2}, \dots , \quad (6.67)$$

and for each given j , the quantum number m (commonly called the magnetic quantum number) can take any of the $2j + 1$ possible values

$$m = -j, -j+1, \dots, j-1, j . \quad (6.68)$$

6.4 Example - Spin 1/2

The vector space of a spin 1/2 system is the subspace spanned by the ket-vectors $|j = 1/2, m = -1/2\rangle$ and $|j = 1/2, m = 1/2\rangle$. In this subspace the spin angular momentum is labeled using the letter \mathbf{S} , as we have discussed above. The matrix representation of some operators of interest in this basis can be easily found with the help of Eqs. (6.63), (6.64), (6.65) and (6.66):

$$\mathbf{S}^2 \doteq \frac{3\hbar^2}{4} \begin{pmatrix} 1 & 0 \\ 0 & 1 \end{pmatrix}, \quad (6.69)$$

$$S_z \doteq \frac{\hbar}{2} \begin{pmatrix} 1 & 0 \\ 0 & -1 \end{pmatrix} \equiv \frac{\hbar}{2} \sigma_z, \quad (6.70)$$

$$S_+ \doteq \hbar \begin{pmatrix} 0 & 1 \\ 0 & 0 \end{pmatrix}, \quad (6.71)$$

$$S_- \doteq \hbar \begin{pmatrix} 0 & 0 \\ 1 & 0 \end{pmatrix}. \quad (6.72)$$

The above results for S_+ and S_- together with the identities

$$S_x = \frac{S_+ + S_-}{2}, \quad (6.73)$$

$$S_y = \frac{S_+ - S_-}{2i}, \quad (6.74)$$

can be used to find the matrix representation of S_x and S_y

$$S_x \doteq \frac{\hbar}{2} \begin{pmatrix} 0 & 1 \\ 1 & 0 \end{pmatrix} \equiv \frac{\hbar}{2} \sigma_x, \quad (6.75)$$

$$S_y \doteq \frac{\hbar}{2} \begin{pmatrix} 0 & -i \\ i & 0 \end{pmatrix} \equiv \frac{\hbar}{2} \sigma_y. \quad (6.76)$$

The matrices σ_x , σ_y and σ_z are called Pauli's matrices, and are related to the corresponding spin angular momentum operators by the relation

$$S_k \doteq \frac{\hbar}{2} \sigma_k. \quad (6.77)$$

6.5 Orbital Angular Momentum

As we have discussed above, orbital angular momentum $\mathbf{L} = \mathbf{r} \times \mathbf{p}$ refers to spatial motion. For this case the states $|l, m\rangle$ (here, the letter l is used instead of j since we are dealing with orbital angular momentum) can be described using wave functions. In this section we calculate these wave functions. For this purpose it is convenient to employ the transformation from Cartesian to spherical coordinates

$$x = r \sin \theta \cos \phi , \quad (6.78)$$

$$y = r \sin \theta \sin \phi , \quad (6.79)$$

$$z = r \cos \theta , \quad (6.80)$$

where

$$r \geq 0 , \quad (6.81)$$

$$0 \leq \theta \leq \pi , \quad (6.82)$$

$$0 \leq \phi \leq 2\pi . \quad (6.83)$$

Exercise 6.5.1. Show that:

1.

$$\langle \mathbf{r}' | L_z | \alpha \rangle = -i\hbar \frac{\partial}{\partial \phi} \langle \mathbf{r}' | \alpha \rangle . \quad (6.84)$$

2.

$$\langle \mathbf{r}' | L_{\pm} | \alpha \rangle = -i\hbar \exp(\pm i\phi) \left(\pm i \frac{\partial}{\partial \theta} - \cot \theta \frac{\partial}{\partial \phi} \right) \langle \mathbf{r}' | \alpha \rangle . \quad (6.85)$$

3.

$$\langle \mathbf{r}' | \mathbf{L}^2 | \alpha \rangle = -\hbar^2 \left[\frac{1}{\sin^2 \theta} \frac{\partial^2}{\partial \phi^2} + \frac{1}{\sin \theta} \frac{\partial}{\partial \theta} \left(\sin \theta \frac{\partial}{\partial \theta} \right) \right] \langle \mathbf{r}' | \alpha \rangle . \quad (6.86)$$

Solution 6.5.1. Using the relations

$$\mathbf{L} = \mathbf{r} \times \mathbf{p} = \det \begin{pmatrix} \hat{\mathbf{x}} & \hat{\mathbf{y}} & \hat{\mathbf{z}} \\ x & y & z \\ p_x & p_y & p_z \end{pmatrix} , \quad (6.87)$$

$$\langle \mathbf{r}' | \mathbf{r} | \alpha \rangle = \mathbf{r}' \langle \mathbf{r}' | \alpha \rangle , \quad (6.88)$$

$$\langle \mathbf{r}' | \mathbf{p} | \alpha \rangle = \frac{\hbar}{i} \nabla \langle \mathbf{r}' | \alpha \rangle , \quad (6.89)$$

[see Eqs. (3.21) and (3.29)] one finds that

$$\langle \mathbf{r}' | L_x | \alpha \rangle = \frac{\hbar}{i} \left(y \frac{\partial}{\partial z} - z \frac{\partial}{\partial y} \right) \psi_{\alpha}(\mathbf{r}') , \quad (6.90)$$

$$\langle \mathbf{r}' | L_y | \alpha \rangle = \frac{\hbar}{i} \left(z \frac{\partial}{\partial x} - x \frac{\partial}{\partial z} \right) \psi_{\alpha}(\mathbf{r}') , \quad (6.91)$$

$$\langle \mathbf{r}' | L_z | \alpha \rangle = \frac{\hbar}{i} \left(x \frac{\partial}{\partial y} - y \frac{\partial}{\partial x} \right) \psi_{\alpha}(\mathbf{r}') , \quad (6.92)$$

where

$$\psi_{\alpha}(\mathbf{r}') = \langle \mathbf{r}' | \alpha \rangle . \quad (6.93)$$

The inverse transformation is given by

$$r = \sqrt{x^2 + y^2 + z^2}, \quad (6.94)$$

$$\cos \theta = \frac{z}{\sqrt{x^2 + y^2 + z^2}}, \quad (6.95)$$

$$\cot \phi = \frac{x}{y}. \quad (6.96)$$

1. The following holds

$$\begin{aligned} \frac{\partial}{\partial \phi} &= \frac{\partial x}{\partial \phi} \frac{\partial}{\partial x} + \frac{\partial y}{\partial \phi} \frac{\partial}{\partial y} + \frac{\partial z}{\partial \phi} \frac{\partial}{\partial z} \\ &= -r \sin \theta \sin \phi \frac{\partial}{\partial x} + r \sin \theta \cos \phi \frac{\partial}{\partial y} \\ &= -y \frac{\partial}{\partial x} + x \frac{\partial}{\partial y}, \end{aligned} \quad (6.97)$$

thus using Eq. (6.92) one has

$$\langle \mathbf{r}' | L_z | \alpha \rangle = -i\hbar \frac{\partial}{\partial \phi} \psi_\alpha(\mathbf{r}'). \quad (6.98)$$

2. Using Eqs. (6.90) and (6.91) together with the relation $L_+ = L_x + iL_y$ one has

$$\begin{aligned} \frac{i}{\hbar} \langle \mathbf{r}' | L_+ | \alpha \rangle &= \frac{i}{\hbar} \langle \mathbf{r}' | L_x + iL_y | \alpha \rangle \\ &= \left(y \frac{\partial}{\partial z} - z \frac{\partial}{\partial y} + iz \frac{\partial}{\partial x} - ix \frac{\partial}{\partial z} \right) \psi_\alpha(\mathbf{r}') \\ &= \left[z \left(i \frac{\partial}{\partial x} - \frac{\partial}{\partial y} \right) - i(x + iy) \frac{\partial}{\partial z} \right] \psi_\alpha(\mathbf{r}') \\ &= \left[z \left(i \frac{\partial}{\partial x} - \frac{\partial}{\partial y} \right) - ir \sin \theta e^{i\phi} \frac{\partial}{\partial z} \right] \psi_\alpha(\mathbf{r}'). \end{aligned} \quad (6.99)$$

Thus, by using the identity

$$\begin{aligned} \frac{\partial}{\partial \theta} &= \frac{\partial x}{\partial \theta} \frac{\partial}{\partial x} + \frac{\partial y}{\partial \theta} \frac{\partial}{\partial y} + \frac{\partial z}{\partial \theta} \frac{\partial}{\partial z} \\ &= r \cos \theta \left(\cos \phi \frac{\partial}{\partial x} + \sin \phi \frac{\partial}{\partial y} \right) - r \sin \theta \frac{\partial}{\partial z}, \end{aligned} \quad (6.100)$$

or

$$r \sin \theta \frac{\partial}{\partial z} = r \cos \theta \left(\cos \phi \frac{\partial}{\partial x} + \sin \phi \frac{\partial}{\partial y} \right) - \frac{\partial}{\partial \theta}, \quad (6.101)$$

one finds that

$$\begin{aligned}
 \frac{i}{\hbar} \langle \mathbf{r}' | L_+ | \alpha \rangle &= \left[z \left(i \frac{\partial}{\partial x} - \frac{\partial}{\partial y} \right) - i e^{i\phi} \left(\cot \theta \left(x \frac{\partial}{\partial x} + y \frac{\partial}{\partial y} \right) - \frac{\partial}{\partial \theta} \right) \right] \psi_\alpha(\mathbf{r}') \\
 &= \left[i (z - e^{i\phi} x \cot \theta) \frac{\partial}{\partial x} - (z + i e^{i\phi} y \cot \theta) \frac{\partial}{\partial y} + i e^{i\phi} \frac{\partial}{\partial \theta} \right] \psi_\alpha(\mathbf{r}') \\
 &= e^{i\phi} \left[i \cot \theta \left(\underbrace{z e^{-i\phi} \tan \theta}_{x-iy} - x \right) \frac{\partial}{\partial x} - \cot \theta \left(\underbrace{z e^{-i\phi} \tan \theta}_{x-iy} + iy \right) \frac{\partial}{\partial y} + i \frac{\partial}{\partial \theta} \right] \psi_\alpha(\mathbf{r}') \\
 &= e^{i\phi} \left[\cot \theta \left(y \frac{\partial}{\partial x} - x \frac{\partial}{\partial y} \right) + i \frac{\partial}{\partial \theta} \right] \psi_\alpha(\mathbf{r}') \\
 &= e^{i\phi} \left(i \frac{\partial}{\partial \theta} - \cot \theta \frac{\partial}{\partial \phi} \right) \psi_\alpha(\mathbf{r}') .
 \end{aligned} \tag{6.102}$$

In a similar way one evaluates $\langle \mathbf{r}' | L_- | \alpha \rangle$. Both results can be expressed as

$$\langle \mathbf{r}' | L_\pm | \alpha \rangle = -i\hbar \exp(\pm i\phi) \left(\pm i \frac{\partial}{\partial \theta} - \cot \theta \frac{\partial}{\partial \phi} \right) \psi_\alpha(\mathbf{r}') . \tag{6.103}$$

3. Using the result of the previous section one has

$$\begin{aligned}
 \langle \mathbf{r}' | L_x | \alpha \rangle &= \frac{1}{2} \langle \mathbf{r}' | (L_+ + L_-) | \alpha \rangle \\
 &= \frac{i\hbar}{2} \left[e^{i\phi} \left(\cot \theta \frac{\partial}{\partial \phi} - i \frac{\partial}{\partial \theta} \right) + e^{-i\phi} \left(\cot \theta \frac{\partial}{\partial \phi} + i \frac{\partial}{\partial \theta} \right) \right] \psi_\alpha(\mathbf{r}') \\
 &= i\hbar \left(\cos \phi \cot \theta \frac{\partial}{\partial \phi} + \sin \phi \frac{\partial}{\partial \theta} \right) \psi_\alpha(\mathbf{r}') .
 \end{aligned} \tag{6.104}$$

Similarly

$$\langle \mathbf{r}' | L_y | \alpha \rangle = i\hbar \left(\sin \phi \cot \theta \frac{\partial}{\partial \phi} - \cos \phi \frac{\partial}{\partial \theta} \right) \psi_\alpha(\mathbf{r}') , \tag{6.105}$$

thus

$$\begin{aligned}
 \langle \mathbf{r}' | \mathbf{L}^2 | \alpha \rangle &= \langle \mathbf{r}' | L_x^2 + L_y^2 + L_z^2 | \alpha \rangle \\
 &= -\hbar^2 \left[\left(\cos \phi \cot \theta \frac{\partial}{\partial \phi} + \sin \phi \frac{\partial}{\partial \theta} \right)^2 + \left(\sin \phi \cot \theta \frac{\partial}{\partial \phi} - \cos \phi \frac{\partial}{\partial \theta} \right)^2 + \frac{\partial^2}{\partial \phi^2} \right] \psi_\alpha(\mathbf{r}') \\
 &= -\hbar^2 \left[(1 + \cot^2 \theta) \frac{\partial^2}{\partial \phi^2} + \cot \theta \frac{\partial}{\partial \theta} + \frac{\partial^2}{\partial \theta^2} \right] \psi_\alpha(\mathbf{r}') \\
 &= -\hbar^2 \left[\frac{1}{\sin^2 \theta} \frac{\partial^2}{\partial \phi^2} + \frac{1}{\sin \theta} \frac{\partial}{\partial \theta} \left(\sin \theta \frac{\partial}{\partial \theta} \right) \right] \psi_\alpha(\mathbf{r}') .
 \end{aligned} \tag{6.106}$$

Spherical Harmonics. The above exercise allows translating the relations (6.63) and (6.64), which are given by

$$\mathbf{L}^2 |l, m\rangle = l(l+1)\hbar^2 |l, m\rangle, \quad (6.107)$$

$$L_z |l, m\rangle = m\hbar |l, m\rangle, \quad (6.108)$$

into differential equations for the corresponding wavefunctions

$$-\left[\frac{1}{\sin^2 \theta} \frac{\partial^2}{\partial \phi^2} + \frac{1}{\sin \theta} \frac{\partial}{\partial \theta} \left(\sin \theta \frac{\partial}{\partial \theta} \right) \right] \psi_\alpha(\mathbf{r}') = l(l+1) \psi_\alpha(\mathbf{r}'), \quad (6.109)$$

$$-i \frac{\partial}{\partial \phi} \psi_\alpha(\mathbf{r}') = m \psi_\alpha(\mathbf{r}'), \quad (6.110)$$

where

$$m = -l, -l+1, \dots, l-1, l. \quad (6.111)$$

We seek solutions having the form

$$\psi_\alpha(\mathbf{r}') = f(r) Y_l^m(\theta, \phi). \quad (6.112)$$

We require that both $f(r)$ and $Y_l^m(\theta, \phi)$ are normalized

$$1 = \int_0^\infty dr r^2 |f(r)|^2, \quad (6.113)$$

$$1 = \int_0^\pi d\theta \sin \theta \int_0^{2\pi} d\phi |Y_l^m(\theta, \phi)|^2. \quad (6.114)$$

These normalization requirements guarantee that the total wavefunction is normalized

$$1 = \int_{-\infty}^\infty dx \int_{-\infty}^\infty dy \int_{-\infty}^\infty dz |\psi_\alpha(\mathbf{r}')|^2. \quad (6.115)$$

Substituting into Eqs. (6.109) and (6.110) yields

$$-\left[\frac{1}{\sin^2 \theta} \frac{\partial^2}{\partial \phi^2} + \frac{1}{\sin \theta} \frac{\partial}{\partial \theta} \left(\sin \theta \frac{\partial}{\partial \theta} \right) \right] Y_l^m = l(l+1) Y_l^m, \quad (6.116)$$

$$-i \frac{\partial}{\partial \phi} Y_l^m = m Y_l^m. \quad (6.117)$$

The functions $Y_l^m(\theta, \phi)$ are called spherical harmonics

In the previous section, which discusses the case of general angular momentum, we have seen that the quantum number m can take any half integer value $0, 1/2, 1, 3/2, \dots$ [see Eq. (6.67)]. Recall that the only assumption employed in order to obtain this result was the commutation relations (6.22).

However, as is shown by the claim below, only integer values are allowed for the case of *orbital* angular momentum. In view of this result, one may argue that the existence of spin, which corresponds to half integer values, is in fact predicted by the commutation relations (6.22) only.

Claim. The variable m must be an integer.

Proof. Consider a solution having the form

$$Y_l^m(\theta, \phi) = F_l^m(\theta) e^{im\phi} . \quad (6.118)$$

Clearly, Eq. (6.117) is satisfied. The requirement

$$Y_l^m(\theta, \phi) = Y_l^m(\theta, \phi + 2\pi) , \quad (6.119)$$

namely, the requirement that $Y_l^m(\theta, \phi)$ is continuous, leads to

$$e^{2\pi im} = 1 , \quad (6.120)$$

thus m must be an integer.

The spherical harmonics $Y_l^m(\theta, \phi)$ can be obtained by solving Eqs. (6.116) and (6.117). However, we will employ an alternative approach, in which in the first step we find the spherical harmonics $Y_l^l(\theta, \phi)$ by solving the equation

$$L_+ |l, l\rangle = 0 , \quad (6.121)$$

which is of first order [contrary to Eq. (6.116), which is of the second order]. Using the identity (6.85), which is given by

$$\langle \mathbf{r}' | L_+ | \alpha \rangle = -i\hbar e^{i\phi} \left(i \frac{\partial}{\partial \theta} - \cot \theta \frac{\partial}{\partial \phi} \right) \langle \mathbf{r}' | \alpha \rangle , \quad (6.122)$$

one has

$$\left(\frac{\partial}{\partial \theta} - l \cot \theta \right) F_l^l(\theta) = 0 . \quad (6.123)$$

The solution is given by

$$F_l^l(\theta) = C_l (\sin \theta)^l , \quad (6.124)$$

where C_l is a normalization constant. Thus, Y_l^l is given by

$$Y_l^l(\theta, \phi) = C_l (\sin \theta)^l e^{il\phi} . \quad (6.125)$$

In the second step we employ the identity (6.66), which is given by

$$J_- |j, m\rangle = \sqrt{j(j+1) - m(m-1)} \hbar |j, m-1\rangle , \quad (6.126)$$

and Eq. (6.85), which is given by

$$\langle \mathbf{r}' | L_{\pm} | \alpha \rangle = -i\hbar \exp(\pm i\phi) \left(\pm i \frac{\partial}{\partial \theta} - \cot \theta \frac{\partial}{\partial \phi} \right) \langle \mathbf{r}' | \alpha \rangle , \quad (6.127)$$

to derive the following recursive relation

$$e^{-i\phi} \left(-\frac{\partial}{\partial \theta} - m \cot \theta \right) Y_l^m(\theta, \phi) = \sqrt{l(l+1) - m(m-1)} Y_l^{m-1}(\theta, \phi) , \quad (6.128)$$

which allows finding $Y_l^m(\theta, \phi)$ for all possible values of m provided that $Y_l^l(\theta, \phi)$ is given. The normalized spherical harmonics are found using this method to be given by

$$Y_l^m(\theta, \phi) = \frac{(-1)^l}{2^l l!} \sqrt{\frac{2l+1}{4\pi} \frac{(l+m)!}{(l-m)!}} e^{im\phi} (\sin \theta)^{-m} \frac{d^{l-m}}{d(\cos \theta)^{l-m}} (\sin \theta)^{2l} . \quad (6.129)$$

As an example, closed form expressions for the cases $l = 0$ and $l = 1$ are given below

$$Y_0^0(\theta, \phi) = \frac{1}{\sqrt{4\pi}} , \quad (6.130)$$

$$Y_1^{\pm 1}(\theta, \phi) = \mp \sqrt{\frac{3}{8\pi}} \sin \theta e^{\pm i\phi} , \quad (6.131)$$

$$Y_1^0(\theta, \phi) = \sqrt{\frac{3}{4\pi}} \cos \theta . \quad (6.132)$$

6.6 Problems

1. Let $R_{\hat{i}}$ (where $i \in \{x, y, z\}$) be the 3×3 rotation matrices (as defined in the lecture). Show that for infinitesimal angle ϕ the following holds

$$[R_{\hat{x}}(\phi), R_{\hat{y}}(\phi)] = 1 - R_{\hat{z}}(\phi^2) , \quad (6.133)$$

where

$$[R_{\hat{x}}(\phi), R_{\hat{y}}(\phi)] = R_{\hat{x}}(\phi) R_{\hat{y}}(\phi) - R_{\hat{y}}(\phi) R_{\hat{x}}(\phi) . \quad (6.134)$$

2. Find a 3×3 rotation matrix $R_{\hat{n}}$, which satisfies

$$R_{\hat{n}} \hat{n} = \hat{z} , \quad (6.135)$$

where $\hat{n} = (\sin \theta \cos \varphi, \sin \theta \sin \varphi, \cos \theta)$ and $\hat{z} = (0, 0, 1)$ are a unit vectors.

3. Show that

$$\exp\left(\frac{iJ_z\phi}{\hbar}\right) J_x \exp\left(-\frac{iJ_z\phi}{\hbar}\right) = J_x \cos \phi - J_y \sin \phi . \quad (6.136)$$

4. The components of the Pauli matrix vector $\boldsymbol{\sigma}$ are given by:

$$\sigma_x = \begin{pmatrix} 0 & 1 \\ 1 & 0 \end{pmatrix}, \quad \sigma_y = \begin{pmatrix} 0 & -i \\ i & 0 \end{pmatrix}, \quad \sigma_z = \begin{pmatrix} 1 & 0 \\ 0 & -1 \end{pmatrix} . \quad (6.137)$$

a) Show that

$$(\boldsymbol{\sigma} \cdot \mathbf{a})(\boldsymbol{\sigma} \cdot \mathbf{b}) = \mathbf{a} \cdot \mathbf{b} + i\boldsymbol{\sigma} \cdot (\mathbf{a} \times \mathbf{b}) , \quad (6.138)$$

where \mathbf{a} and \mathbf{b} are vector operators which commute with $\boldsymbol{\sigma}$, but not necessarily commute with each other.

b) Show that

$$\exp\left(-\frac{i\boldsymbol{\sigma} \cdot \hat{\mathbf{n}}\phi}{2}\right) = \mathbf{1} \cos \frac{\phi}{2} - i\boldsymbol{\sigma} \cdot \hat{\mathbf{n}} \sin \frac{\phi}{2} , \quad (6.139)$$

where $\hat{\mathbf{n}}$ is a unit vector and where $\mathbf{1}$ is the 2×2 identity matrix.

5. Find the eigenvectors and eigenvalues of the matrix $\boldsymbol{\sigma} \cdot \hat{\mathbf{n}}$ ($\hat{\mathbf{n}}$ is a unit vector).
6. Consider an electron in a state in which the component of its spin along the z axis is $+\hbar/2$. What is the probability that the component of the spin along an axis z' , which makes an angle θ with the z axis, will be measured to be $+\hbar/2$ or $-\hbar/2$. What is the average value of the component of the spin along this axis?
7. Consider the 2×2 matrix

$$S = \boldsymbol{\sigma} \cdot \mathbf{a} , \quad (6.140)$$

where $\mathbf{a} = (a_x, a_y, a_z) = \mathbf{a}' + i\mathbf{a}''$, both vectors $\mathbf{a}' = (a'_x, a'_y, a'_z)$ and $\mathbf{a}'' = (a''_x, a''_y, a''_z)$ are real, and $\boldsymbol{\sigma} = (\sigma_x, \sigma_y, \sigma_z)$ is the Pauli matrix vector (6.137).

- a) Show that $S^2 = 0$ provided that $\mathbf{a}'^2 - \mathbf{a}''^2 = 0$ and $\mathbf{a}' \cdot \mathbf{a}'' = 0$.
- b) The transformed matrix \tilde{S} is defined by

$$\tilde{S} = U^{-1} S U , \quad (6.141)$$

where U is a given 2×2 invertible matrix. Show that the matrix \tilde{S} can be expressed as $\tilde{S} = \boldsymbol{\sigma} \cdot \tilde{\mathbf{a}}$, where $\tilde{\mathbf{a}} = \tilde{\mathbf{a}}' + i\tilde{\mathbf{a}}''$, both vectors $\tilde{\mathbf{a}}'$ and $\tilde{\mathbf{a}}''$ are real, and that the following holds

$$\mathbf{a}'^2 - \mathbf{a}''^2 = \tilde{\mathbf{a}}'^2 - \tilde{\mathbf{a}}''^2 , \quad (6.142)$$

and

$$\mathbf{a}' \cdot \mathbf{a}'' = \tilde{\mathbf{a}}' \cdot \tilde{\mathbf{a}}'' . \quad (6.143)$$

- c) Calculated the eigenvalues of the matrices $S^\dagger S$ and SS^\dagger .
d) Consider the transformation (6.141) for the case where U is given by

$$U = \exp\left(-\frac{i\boldsymbol{\sigma} \cdot \hat{\mathbf{n}}\phi}{2}\right), \quad (6.144)$$

where both unit vector $\hat{\mathbf{n}}$ and angle ϕ are real. Show that for this case

$$\tilde{S} = \boldsymbol{\sigma} \cdot \tilde{\mathbf{a}}, \quad (6.145)$$

where $\tilde{\mathbf{a}}$ is given by

$$\tilde{\mathbf{a}} = \mathbf{a}_\parallel + \mathbf{a}_\perp \cos \phi + (\mathbf{a}_\perp \times \hat{\mathbf{n}}) \sin \phi, \quad (6.146)$$

the vector $\mathbf{a}_\parallel = (\hat{\mathbf{n}} \cdot \mathbf{a}) \hat{\mathbf{n}}$ is the parallel to $\hat{\mathbf{n}}$ component of \mathbf{a} , $\mathbf{a}_\perp = \hat{\mathbf{n}} \times (\mathbf{a} \times \hat{\mathbf{n}})$ is the perpendicular component, and $\mathbf{a} = \mathbf{a}_\parallel + \mathbf{a}_\perp$ [see Eq. (14.88)].

- e) Consider the transformation (6.146) for the case where the unit vector $\hat{\mathbf{n}}$ is chosen to be given by

$$\hat{\mathbf{n}} = \frac{\hat{\mathbf{z}} \times \hat{\mathbf{c}}}{|\hat{\mathbf{z}} \times \hat{\mathbf{c}}|}, \quad (6.147)$$

the angle ϕ is chosen such that $\cos \phi = \hat{\mathbf{z}} \cdot \hat{\mathbf{c}}$ and $\sin \phi = -|\hat{\mathbf{z}} \times \hat{\mathbf{c}}|$, and $\hat{\mathbf{c}}$ is a given real unit vector. Show that for this case the transformation (6.146) maps $\mathbf{a} = \hat{\mathbf{z}}$ to $\tilde{\mathbf{a}} = \hat{\mathbf{c}}$. Using this result show that the matrix representation of $S = \boldsymbol{\sigma} \cdot \mathbf{a}$ in a basis made of the common eigenvectors of $S^\dagger S$ and SS^\dagger is given by $\tilde{S} = \boldsymbol{\sigma} \cdot \tilde{\mathbf{a}}$, where

$$\tilde{\mathbf{a}} = \hat{\mathbf{z}} \times \left(\frac{(\hat{\mathbf{n}} \cdot \mathbf{a})(1 - \hat{\mathbf{z}} \cdot \hat{\mathbf{c}})}{|\hat{\mathbf{z}} \times \hat{\mathbf{c}}|} \hat{\mathbf{c}} + \mathbf{a} \times \hat{\mathbf{c}} \right), \quad (6.148)$$

and where the unit vector $\hat{\mathbf{c}}$ is given by

$$\hat{\mathbf{c}} = \frac{\mathbf{a}'' \times \mathbf{a}'}{|\mathbf{a}'' \times \mathbf{a}'|}. \quad (6.149)$$

Note that $\tilde{\mathbf{a}} \cdot \hat{\mathbf{z}} = 0$, thus the matrix \tilde{S} has a hollow form

$$\tilde{S} = \begin{pmatrix} 0 & \zeta_1 \\ \zeta_2 & 0 \end{pmatrix}. \quad (6.150)$$

The off diagonal entries ζ_1 and ζ_2 satisfy the relation [recall that $\det \tilde{S} = \det S = \det(\boldsymbol{\sigma} \cdot \mathbf{a}) = -\mathbf{a} \cdot \mathbf{a}$]

$$\zeta_1 \zeta_2 = \mathbf{a} \cdot \mathbf{a}. \quad (6.151)$$

Moreover, the relations (6.306) and (6.307) imply that

$$|\zeta_1|^2 + |\zeta_2|^2 = 2\mathbf{a} \cdot \mathbf{a}^* , \quad (6.152)$$

and

$$|\zeta_2|^2 - |\zeta_1|^2 = 4|\mathbf{a}'' \times \mathbf{a}'| . \quad (6.153)$$

8. The 2×2 matrix U is given by

$$U = \frac{1 + i\alpha(\boldsymbol{\sigma} \cdot \hat{\mathbf{n}})}{1 - i\alpha(\boldsymbol{\sigma} \cdot \hat{\mathbf{n}})} , \quad (6.154)$$

where

$$\boldsymbol{\sigma} = \sigma_x \hat{\mathbf{x}} + \sigma_y \hat{\mathbf{y}} + \sigma_z \hat{\mathbf{z}} \quad (6.155)$$

is the Pauli vector matrix,

$$\hat{\mathbf{n}} = n_x \hat{\mathbf{x}} + n_y \hat{\mathbf{y}} + n_z \hat{\mathbf{z}} \quad (6.156)$$

is a unit vector, i.e. $\hat{\mathbf{n}} \cdot \hat{\mathbf{n}} = 1$, and n_x, n_y, n_z and α are all real parameters. Note that generally for a matrix or an operator $\frac{1}{A} \equiv A^{-1}$.

- a) show that U is unitary.
- b) Show that

$$\frac{dU}{d\alpha} = \frac{2i(\boldsymbol{\sigma} \cdot \hat{\mathbf{n}})}{1 + \alpha^2} U . \quad (6.157)$$

- c) Calculate U by solving the differential equation in the previous section.

9. The 2×2 matrix $\Sigma(K)$ is defined by

$$\Sigma(K) = k_0 \sigma_0 + \mathbf{k} \cdot \boldsymbol{\sigma} , \quad (6.158)$$

where $K = (k_0, \mathbf{k})$, k_0 is a real number, $\mathbf{k} = (k_x, k_y, k_z)$ is a real vector, σ_0 is the 2×2 identity matrix, and $\boldsymbol{\sigma} = (\sigma_x, \sigma_y, \sigma_z)$ is the Pauli matrix vector [see Eq. (6.137)]. Calculate $f(\Sigma(K))$, where $f(x)$ is an arbitrary smooth function. Express the result in the form

$$f(\Sigma(K)) = \Sigma(K_f) , \quad (6.159)$$

and derive an expression for K_f .

10. Show that

$$\exp\left(\theta \frac{\sigma_- e^{i\varphi} - \sigma_+ e^{-i\varphi}}{2}\right) = e^{e^{i\varphi} \tan \frac{\theta}{2} \sigma_-} e^{-\log(1 + \tan^2 \frac{\theta}{2}) \frac{\sigma_z}{2}} e^{-e^{-i\varphi} \tan \frac{\theta}{2} \sigma_+} , \quad (6.160)$$

and

$$\exp\left(\theta \frac{\sigma_- e^{i\varphi} - \sigma_+ e^{-i\varphi}}{2}\right) = \exp\left(-\frac{i\varphi\sigma_z}{2}\right) \exp\left(-\frac{i\theta\sigma_y}{2}\right) \exp\left(\frac{i\varphi\sigma_z}{2}\right), \quad (6.161)$$

where both θ and φ are real, σ_x , σ_y and σ_z are Pauli matrices (6.137), and

$$\sigma_+ = \frac{\sigma_x + i\sigma_y}{2} = \begin{pmatrix} 0 & 1 \\ 0 & 0 \end{pmatrix}, \quad (6.162)$$

$$\sigma_- = \frac{\sigma_x - i\sigma_y}{2} = \begin{pmatrix} 0 & 0 \\ 1 & 0 \end{pmatrix}. \quad (6.163)$$

Show that the results (6.160) and (6.161) can be generalized for a general spin angular momentum operator $\mathbf{S} = (S_x, S_y, S_z)$

$$\exp\left(\theta \frac{S_- e^{i\varphi} - S_+ e^{-i\varphi}}{2\hbar}\right) = e^{e^{i\varphi} \tan \frac{\theta}{2} \hbar^{-1} S_-} e^{-\log(1 + \tan^2 \frac{\theta}{2}) \hbar^{-1} S_z} e^{-e^{-i\varphi} \tan \frac{\theta}{2} \hbar^{-1} S_+}, \quad (6.164)$$

and

$$\exp\left(\theta \frac{S_- e^{i\varphi} - S_+ e^{-i\varphi}}{2\hbar}\right) = \exp\left(-\frac{i\varphi S_z}{\hbar}\right) \exp\left(-\frac{i\theta S_y}{\hbar}\right) \exp\left(\frac{i\varphi S_z}{\hbar}\right), \quad (6.165)$$

where $S_{\pm} = S_x \pm iS_y$.

11. The dynamics of a given system is governed by the Hamiltonian \mathcal{H} . Let A_1 and A_2 be observables that do not depend on time explicitly. The following is assumed to hold

$$[A_1, \mathcal{H}] = -i\hbar\omega A_2, \quad (6.166)$$

$$[A_2, \mathcal{H}] = i\hbar\omega A_1, \quad (6.167)$$

where ω is a real constant. Calculate the expectation values $\langle A_1 \rangle(t)$ and $\langle A_2 \rangle(t)$ at time t in terms of their initial values at time $t = 0$, which are labeled as $\langle A_1 \rangle(t = 0)$ and $\langle A_2 \rangle(t = 0)$, respectively.

12. Consider the space of wavefunctions spanned by the spherical harmonics $Y_{l=1}^m(\theta, \phi)$, where $m \in \{-1, 0, 1\}$. Find a normalized wavefunction $\psi_n(\theta, \phi)$, which represents an eigenvector of L_n with a vanishing eigenvalue, where $n \in \{x, y, z\}$ and $\mathbf{L} = (L_x, L_y, L_z)$ is the orbital angular momentum vector. Show that the set $\{\psi_x(\theta, \phi), \psi_y(\theta, \phi), \psi_z(\theta, \phi)\}$ forms an orthonormal basis for the space.
13. Consider a spin $S = 1$ particle. Let $|\hat{\mathbf{n}}\rangle$ be an eigenvector of $\hat{\mathbf{n}} \cdot \mathbf{S}$ with an eigenvalue $+\hbar$, where $\hat{\mathbf{n}} = (\sin\theta \cos\varphi, \sin\theta \sin\varphi, \cos\theta)$ is a unit vector, i.e. $(\hat{\mathbf{n}} \cdot \mathbf{S})|\hat{\mathbf{n}}\rangle = \hbar|\hat{\mathbf{n}}\rangle$. Calculate the expectation value $E(\hat{\mathbf{n}}) = \langle \hat{\mathbf{n}} | \mathcal{H} | \hat{\mathbf{n}} \rangle$, where the Hamiltonian \mathcal{H} is given by

$$\frac{\mathcal{H}}{\hbar} = -\frac{\boldsymbol{\omega} \cdot \mathbf{S}}{\hbar} + \frac{\mathbf{S}^T M_N \mathbf{S}}{\hbar^2}, \quad (6.168)$$

where $\boldsymbol{\omega} = (\omega_x, \omega_y, \omega_z)$, $\mathbf{S} = (S_x, S_y, S_z)$, and where the 3×3 matrix M_N is given by $M_N = \text{diag}(N_x, N_y, N_z)$ (i.e. $\mathbf{S}^T M_N \mathbf{S} = N_x S_x^2 + N_y S_y^2 + N_z S_z^2$).

14. The two normalized spin 1/2 states $|\alpha_1\rangle$ and $|\alpha_2\rangle$ are assumed to be independent (i.e. the dimensionality of the subspace spanned by $|\alpha_1\rangle$ and $|\alpha_2\rangle$ is 2). Let A be an operator that satisfies the following relations

$$A |\alpha_1\rangle = z |\alpha_2\rangle, \quad (6.169)$$

$$A |\alpha_2\rangle = z^* |\alpha_1\rangle, \quad (6.170)$$

where z is a complex number. Calculate the eigenvalues of A .

15. A particle is located in a box, which is divided into a left and right sections. The corresponding vector states are denoted as $|L\rangle$ and $|R\rangle$ respectively. The Hamiltonian of the system is given by

$$\mathcal{H} = E_L |L\rangle \langle L| + E_R |R\rangle \langle R| + \Delta (|L\rangle \langle R| + |R\rangle \langle L|). \quad (6.171)$$

The particle at time $t = 0$ is in the left section

$$|\psi(t=0)\rangle = |L\rangle. \quad (6.172)$$

Calculate the probability $p_R(t)$ to find the particle in the state $|R\rangle$ at time t .

16. **magnetic resonance** - A magnetic field given by

$$\mathbf{B}(t) = B_0 \hat{\mathbf{z}} + B_1 (\cos(\omega t) \hat{\mathbf{x}} + \sin(\omega t) \hat{\mathbf{y}}), \quad (6.173)$$

is applied to a spin 1/2 particle. At time $t = 0$ the state is given by

$$|\alpha\rangle(t=0) = |+\hat{\mathbf{z}}\rangle. \quad (6.174)$$

Calculate the probability $P_{+-}(t)$ to find the system in the state $|-\hat{\mathbf{z}}\rangle$ at time $t > 0$.

17. The Hamiltonian \mathcal{H} of a qubit is represented by a 2×2 matrix H given by

$$\frac{H}{\hbar} = \begin{pmatrix} \omega_{11} & \omega_{12} \\ \omega_{21} & \omega_{22} \end{pmatrix}, \quad (6.175)$$

where $\omega_{n',n''}$ are allowed to vary in time. The unitary transformation u , which is given by

$$u = \begin{pmatrix} e^{-i \int_0^t dt' \omega_{11}(t')} & 0 \\ 0 & e^{-i \int_0^t dt' \omega_{22}(t')} \end{pmatrix}, \quad (6.176)$$

transforms H to H' , which is given by [see Eq. (6.375)]

$$\frac{H'}{\hbar} = -iu^\dagger (du/dt) + u^\dagger \frac{H}{\hbar} u . \quad (6.177)$$

Calculate H' for the case where

$$\omega_{11} = \frac{\Omega_0 - \Omega_{L1} \cos(\Omega_L t)}{2} ,$$

$$\omega_{12} = \frac{\Omega_{T1} e^{-i\Omega_T t}}{2} ,$$

$\omega_{22} = -\omega_{11}$, and $\omega_{21} = \omega_{12}^*$, where Ω_0 , Ω_{L1} , Ω_L , Ω_{T1} and Ω_T are all real constants, and time is denoted by t . Employ the Jacobi-Anger expansion to simplify the result.

18. **Bloch-Siegert shift** - A magnetic field $\mathbf{B}(t)$ given by

$$\begin{aligned} \mathbf{B}(t) &= B_0 \hat{\mathbf{z}} + \sum_{n \neq 0} B_n (\cos(n\omega t) \hat{\mathbf{x}} + \sin(n\omega t) \hat{\mathbf{y}}) \\ &= B_0 \hat{\mathbf{z}} + \sum_{n \neq 0} B_n (e^{in\omega t} \hat{\mathbf{u}}_- + e^{-in\omega t} \hat{\mathbf{u}}_+) , \end{aligned} \quad (6.178)$$

where $B_n = (m_e c / |e|) \omega_n$, all ω_n are constants, n is integer and $\hat{\mathbf{u}}_{\pm} = (1/2)(\hat{\mathbf{x}} \pm i\hat{\mathbf{y}})$, is applied to a spin 1/2 particle. Note that when $\omega_n = 0$ for all $n \neq 0, 1$, the magnetic field $\mathbf{B}(t)$ becomes identical to the one given by Eq. (6.173). For that case the resonance (Larmor) angular frequency is ω_0 . Find an approximate expression for the resonance frequency shift induced by the oscillating terms proportional to ω_n for $n \neq 0, 1$.

19. **frequency mixing** - A magnetic field given by

$$\mathbf{B}(t) = B_0 \hat{\mathbf{z}} + B_1 (\cos(\omega t) \hat{\mathbf{x}} + \sin(\omega t) \hat{\mathbf{y}}) , \quad (6.179)$$

is applied to a spin 1/2 particle, where ω is a constant, $B_0 = (m_e c / |e|) \omega_f$ and $B_1 = (m_e c / |e|) \omega_1$. While ω_1 is a constant, ω_f varies in time according to

$$\omega_f(t) = \omega_{f0} - \omega_{f1} \cos(\omega_p t) , \quad (6.180)$$

where ω_{f0} and ω_{f1} are constants. Consider the case where $\omega + l\omega_p \simeq \omega_{f0}$, where l is an integer.

- Derive an effective time-independent Hamiltonian for this case.
- Calculate the Bloch-Siegert shift of the l 'th resonance for the case where $\omega_p = \omega$. For this calculation assume that, instead of Eq. (6.179), the magnetic field $\mathbf{B}(t)$ is given by [compare with Eq. (6.410)]

$$\mathbf{B}(t) = B_0 \hat{\mathbf{z}} + 2B_1 \cos(\omega t) \hat{\mathbf{x}} . \quad (6.181)$$

20. **Spin decoupling** - Consider a system composed of two spin 1/2 having Larmor frequencies ω_s and ω_n , respectively. The Hamiltonian \mathcal{H} is given by

$$\begin{aligned} \hbar^{-1}\mathcal{H} = & \omega_s S_z + \omega_1 (\cos(\omega t) S_x + \sin(\omega t) S_y) \\ & + \omega_n I_z + 2\hbar^{-1} A I_z S_z, \end{aligned} \quad (6.182)$$

where $\mathbf{S} = (S_x, S_y, S_z)$ and $\mathbf{I} = (I_x, I_y, I_z)$ are angular momentum vectors of the first and second spin, respectively. The term proportional to ω_1 represents driving applied to the first spin, and the term proportional to A represents dipolar coupling between the spins. Calculate the energy eigenvectors and eigenvalues.

21. A magnetic field given by

$$\mathbf{B}(t) = B_0 \hat{\mathbf{z}} + g(t) B_1 (\hat{\mathbf{x}} \cos(\omega t) + \hat{\mathbf{y}} \sin(\omega t)) \quad (6.183)$$

is applied to a spin 1/2 particle. While B_0 , B_1 and ω_1 are taken to be constants, the function $g(t)$ is assumed to be given by

$$g(t) = \begin{cases} 0 & t < 0 \\ 1 & 0 \leq t < \tau_p \\ 0 & \tau_p \leq t < \tau_p + \tau_0 \\ 1 & \tau_p + \tau_0 \leq t < 2\tau_p + \tau_0 \\ 0 & 2\tau_p + \tau_0 \leq t \end{cases}, \quad (6.184)$$

i.e. two oscillatory magnetic field pulses, both having duration of τ_p , are applied, and the dwell time between these pulses is τ_0 . The normalized pulse duration α_p is defined to be

$$\alpha_p = \omega_1 \tau_p, \quad (6.185)$$

the normalized dwell time α_0 is defined to be

$$\alpha_0 = \Delta_\omega \tau_0, \quad (6.186)$$

and the normalized detuning δ is defined to be

$$\delta = \frac{\Delta_\omega}{\omega_1}, \quad (6.187)$$

where

$$\Delta_\omega = \omega_0 - \omega,$$

and where

$$\omega_0 = \frac{|e| B_0}{m_e c}, \quad (6.188)$$

$$\omega_1 = \frac{|e| B_1}{m_e c}. \quad (6.189)$$

At time $t = 0$ the state is assumed to be given by

$$|\alpha\rangle(t=0) = |+\rangle; \hat{\mathbf{z}} \rangle . \quad (6.190)$$

Calculate the probability $P_{++}(t)$ to find the system in the state $|+\rangle; \hat{\mathbf{z}}\rangle$ at time $t > 2\tau_p + \tau_0$. Assume that the normalized detuning is small, i.e. $|\delta| \ll 1$, and expand $P_{++}(t)$ to lowest nonvanishing order in δ for the case where the normalized pulse duration is taken to be given by

$$\alpha_p = \frac{\pi}{2} . \quad (6.191)$$

22. Find the time evolution of the state vector of a spin 1/2 particle in a magnetic field along the z direction with time dependent magnitude $\mathbf{B}(t) = B(t)\hat{\mathbf{z}}$.
23. A magnetic field given by $\mathbf{B} = B \cos(\omega t)\hat{\mathbf{z}}$, where B is a constant, is applied to a spin 1/2. At time $t = 0$ the spin is in state $|\psi(t)\rangle$, which satisfies

$$S_x |\psi(t=0)\rangle = \frac{\hbar}{2} |\psi(t=0)\rangle , \quad (6.192)$$

Calculate the expectation value $\langle S_z \rangle$ at time $t \geq 0$.

24. Consider a spin 1/2 particle. The time dependent Hamiltonian is given by

$$\mathcal{H} = -\frac{4\omega S_z}{1 + (\omega t)^2} , \quad (6.193)$$

where ω is a real non-negative constant and S_z is the z component of the angular momentum operator. Calculate the time evolution operator u of the system.

25. Consider a spin 1/2 particle in an eigenstate of the operator $\mathbf{S} \cdot \hat{\mathbf{n}}$ with eigenvalue $+\hbar/2$, where \mathbf{S} is the vector operator of angular momentum and where $\hat{\mathbf{n}}$ is a unit vector. The angle between the unit vector $\hat{\mathbf{n}}$ and the z axis is θ . Calculate the expectation values
- $\langle S_z \rangle$
 - $\langle (\Delta S_z)^2 \rangle$
26. An ensemble of spin 1/2 particles are in a normalized state

$$|\psi\rangle = \alpha |+\rangle + \beta |-\rangle ,$$

where the states $|+\rangle$ and $|-\rangle$ are the eigenstates of S_z (the z component of the angular momentum operator). At what direction the magnetic field should be aligned in a Stern-Gerlach experiment in order for the beam not to split.

27. Consider a spin 1/2 particle having gyromagnetic ratio γ in a magnetic field given by $B(t) \hat{\mathbf{u}}$. The unit vector is given by

$$\hat{\mathbf{u}} = (\sin \theta \cos \varphi, \sin \theta \sin \varphi, \cos \theta) , \quad (6.194)$$

where θ, φ are angles in spherical coordinates. The field intensity is given by

$$B(t) = \begin{cases} 0 & t < 0 \\ B_0 & 0 < t < \tau \\ 0 & t > \tau \end{cases} . \quad (6.195)$$

At times $t < 0$ the spin was in state $|+\rangle$, namely in eigenstate of S_z with positive eigenvalue. Calculate the probability $P_-(t)$ to find the spin in state $|-\rangle$ at time t , where $t > \tau$.

28. Consider a spin 1/2 particle. The Hamiltonian is given by

$$\mathcal{H} = \omega S_x , \quad (6.196)$$

where ω is a Larmor frequency and where S_x is the x component of the angular momentum operator. The z component of the angular momentum is measured at the times $t_n = nT/N$ where $n = 0, 1, 2, \dots, N$, N is integer and T is the time of the last measurement.

- Find the matrix representation of the time evolution operator $u(t)$ in the basis of $|\pm; \hat{\mathbf{z}}\rangle$ states.
 - What is the probability p_{same} to get the same result in all $N + 1$ measurements. Note that the initial state of the particle is unknown.
 - For a fixed T calculate the limit $\lim_{N \rightarrow \infty} p_{\text{same}}$.
29. Consider a spin 1/2 particle. No external magnetic field is applied. Three measurements are done one after the other. In the first one the z component of the angular momentum is measured, in the second one the component along the direction $\hat{\mathbf{u}}$ is measured and in the third measurement, again the z component is measured. The unit vector $\hat{\mathbf{u}}$ is described using the angles θ and φ

$$\hat{\mathbf{u}} = (\sin \theta \cos \varphi, \sin \theta \sin \varphi, \cos \theta) . \quad (6.197)$$

Calculate the probability p_{same} to have the same result in the 1st and 3rd measurements.

30. Let $\langle \boldsymbol{\mu} \rangle(t)$ be the expectation value of the magnetic moment associated with spin 1/2 particle ($\boldsymbol{\mu} = \gamma \mathbf{S}$, where \mathbf{S} is the angular momentum and γ is the gyromagnetic ratio). Show that in the presence of a time varying magnetic field $\mathbf{B}(t)$ the following holds

$$\frac{d}{dt} \langle \boldsymbol{\mu} \rangle(t) = \gamma \langle \boldsymbol{\mu} \rangle(t) \times \mathbf{B}(t) . \quad (6.198)$$

31. **Spin coherent states** - Consider a spin S particle, where $S \in (1/2, 1, 3/2, \dots)$. The common eigenvectors of \mathbf{S}^2 and S_z are denoted by $|S, m\rangle$, where $m \in \{-S, -S+1, \dots, S\}$, and the following holds [see Eqs. (6.63) and (6.64)]

$$\mathbf{S}^2 |S, m\rangle = S(S+1)\hbar^2 |S, m\rangle, \quad (6.199)$$

$$S_z |S, m\rangle = m\hbar |S, m\rangle. \quad (6.200)$$

For a given unit vector $\hat{\mathbf{n}} = (\sin\theta \cos\varphi, \sin\theta \sin\varphi, \cos\theta)$, where both θ and φ are real, the spin coherent state $|\hat{\mathbf{n}}\rangle$ is defined by [compare with Eq. (5.35)]

$$|\hat{\mathbf{n}}\rangle = \exp\left(\theta \frac{S_- e^{i\varphi} - S_+ e^{-i\varphi}}{2\hbar}\right) |S, S\rangle, \quad (6.201)$$

where $S_{\pm} = S_x \pm iS_y$.

- a) Show that

$$|\hat{\mathbf{n}}\rangle = \exp\left(\frac{i\theta \hat{\mathbf{c}} \cdot \mathbf{S}}{\hbar}\right) |S, S\rangle. \quad (6.202)$$

where

$$\hat{\mathbf{c}} = \frac{\hat{\mathbf{n}} \times \hat{\mathbf{z}}}{|\hat{\mathbf{n}} \times \hat{\mathbf{z}}|} = (\sin\varphi, -\cos\varphi, 0). \quad (6.203)$$

- b) Show that

$$|\hat{\mathbf{n}}\rangle = \cos^{2S} \frac{\theta}{2} e^{i\varphi \tan \frac{\theta}{2} \hbar^{-1} S_-} |S, S\rangle. \quad (6.204)$$

- c) Show that

$$|\hat{\mathbf{n}}\rangle = \exp\left(-\frac{i\varphi S_z}{\hbar}\right) \exp\left(-\frac{i\theta S_y}{\hbar}\right) \exp\left(\frac{i\varphi S_z}{\hbar}\right) |S, S\rangle. \quad (6.205)$$

- d) Show that

$$\mathbf{P} = \hat{\mathbf{n}}, \quad (6.206)$$

where the polarization vector \mathbf{P} is defined by

$$\mathbf{P} = \frac{1}{\hbar S} \langle \hat{\mathbf{n}} | \mathbf{S} | \hat{\mathbf{n}} \rangle. \quad (6.207)$$

- e) The Hamiltonian \mathcal{H} is given by

$$\mathcal{H} = \omega_0 S_z. \quad (6.208)$$

Calculate the time evolution of the state $|\hat{\mathbf{n}}\rangle$.

f) Show that

$$|\langle \hat{\mathbf{n}}'' | \hat{\mathbf{n}}' \rangle| = \left(\frac{1 + \hat{\mathbf{n}}'' \cdot \hat{\mathbf{n}}'}{2} \right)^S. \quad (6.209)$$

g) Show that

$$\frac{2S+1}{4\pi} \int_{-1}^1 d(\cos\theta) \int_0^{2\pi} d\varphi |\hat{\mathbf{n}}\rangle \langle \hat{\mathbf{n}}| = 1. \quad (6.210)$$

h) Show that

$$\langle \hat{\mathbf{n}}'' | S_z | \hat{\mathbf{n}}' \rangle = S \zeta_+^{2S-1} \zeta_-, \quad (6.211)$$

where

$$\zeta_{\pm} = \cos \frac{\theta'}{2} \cos \frac{\theta''}{2} \pm e^{i(\varphi' - \varphi'')} \sin \frac{\theta'}{2} \sin \frac{\theta''}{2}. \quad (6.212)$$

Note that $\langle \hat{\mathbf{n}}'' | \hat{\mathbf{n}}' \rangle = \zeta_+^{2S}$ [see Eq. (6.530)], and thus Eq. (6.211) yields $\hbar^{-1} \langle \hat{\mathbf{n}}' | S_z | \hat{\mathbf{n}}' \rangle = S \cos \theta'$ for the case $\hat{\mathbf{n}}'' = \hat{\mathbf{n}}'$.

32. Consider a spin S particle, where $S \in (1/2, 1, 3/2, \dots)$, whose Hamiltonian \mathcal{H} is given by

$$\frac{\mathcal{H}}{\hbar} = -\frac{\gamma \mathbf{B} \cdot \mathbf{S}}{\hbar} + \omega_A \frac{N_x S_x^2 + N_y S_y^2 + N_z S_z^2}{\hbar^2}, \quad (6.213)$$

where γ is a gyromagnetic ratio, \mathbf{B} is an applied magnetic field, \mathbf{S} is the angular momentum vector operator, and the angular frequency ω_A and the dimensionless coefficients N_x , N_y and N_z are constants.

a) Derive an equation of motion for $\langle \mathbf{S} \rangle$.

b) Simplify the equation of motion by assuming that the approximation $S_z = -S\hbar$ can be implemented. This approximation is commonly employed when the spin remains very close to its ground state (due to either sufficiently low temperature or due to the so-called effect of magnetic ordering). Assume that the applied magnetic field \mathbf{B} is given by

$$\gamma \mathbf{B}(t) = (\omega_0 + \omega_1 \cos(\omega t)) \hat{\mathbf{z}}, \quad (6.214)$$

where ω_0 , ω_1 and ω are constants and t is time.

33. **Dark state** - Consider a three-state system in the so-called Λ configuration. The energy of the state $|n\rangle$ is $\hbar\omega_n$, where $n \in \{1, 2, 3\}$. The transition $|1\rangle \leftrightarrow |3\rangle$ ($|2\rangle \leftrightarrow |3\rangle$) is externally driven at angular frequencies $\omega_3 - \omega_1 + \Delta_p$ ($\omega_3 - \omega_2 + \Delta_s$), where Δ_p (Δ_s) is the detuning. The corresponding Rabi angular frequency is denoted by $\Omega_p e^{i\phi_p}$ ($\Omega_s e^{i\phi_s}$), where Ω_p (Ω_s) is non-negative and ϕ_p (ϕ_s) is real. Under what conditions the probability to find the system in the state $|3\rangle$ vanishes in steady state?

34. The Hamiltonian of an electron of mass m , charge q , spin $1/2$, placed in electromagnetic field described by the vector potential $\mathbf{A}(\mathbf{r}, t)$ and the scalar potential $\varphi(\mathbf{r}, t)$, can be written as [see Eq. (1.62)]

$$\mathcal{H} = \frac{(\mathbf{p} - \frac{q}{c}\mathbf{A})^2}{2m} + q\varphi - \frac{q\hbar}{2mc}\boldsymbol{\sigma} \cdot \mathbf{B}, \quad (6.215)$$

where $\mathbf{B} = \nabla \times \mathbf{A}$. Show that this Hamiltonian can also be written as

$$\mathcal{H} = \frac{1}{2m} \left[\boldsymbol{\sigma} \cdot \left(\mathbf{p} - \frac{q}{c}\mathbf{A} \right) \right]^2 + q\varphi. \quad (6.216)$$

35. Show that

$$\langle j, m | [(\Delta J_x)^2 + (\Delta J_y)^2] | j, m \rangle = \hbar^2 (j^2 + j - m^2). \quad (6.217)$$

36. Find the condition under which the Hamiltonian of a charged particle in a magnetic field

$$\mathcal{H} = \frac{1}{2m} \left(\mathbf{p} - \frac{q}{c}\mathbf{A} \right)^2. \quad (6.218)$$

can be written as

$$\mathcal{H} = \frac{1}{2m}\mathbf{p}^2 - \frac{q}{mc}\mathbf{p} \cdot \mathbf{A} + \frac{q^2}{2mc^2}\mathbf{A}^2. \quad (6.219)$$

37. Consider a point particle having mass m and charge q moving under the influence of electric field \mathbf{E} and magnetic field \mathbf{B} , which are related to the scalar potential φ and to the vector potential \mathbf{A} by

$$\mathbf{E} = -\nabla\varphi - \frac{1}{c}\frac{\partial\mathbf{A}}{\partial t}, \quad (6.220)$$

and

$$\mathbf{B} = \nabla \times \mathbf{A}. \quad (6.221)$$

Find the coordinates representation of the time-independent Schrödinger equation $\mathcal{H}|\alpha\rangle = E|\alpha\rangle$.

38. A particle of mass m and charge e interacts with a vector potential

$$A_x = A_z = 0, \quad (6.222)$$

$$A_y = Bx. \quad (6.223)$$

Calculate the ground state energy. Clue: Consider a wave function of the form

$$\psi(x, y, z) = \chi(x) \exp(ik_y y) \exp(ik_z z). \quad (6.224)$$

39. Find the energy spectrum of a charged particle having mass m and charge q moving in uniform and time-independent magnetic field $\mathbf{B} = B\hat{\mathbf{z}}$ and electric field $\mathbf{E} = E\hat{\mathbf{x}}$.
40. Consider a particle having mass m and charge e moving in xy plane under the influence of the potential $U(y) = \frac{1}{2}m\omega_0^2 y^2$. A uniform and time-independent magnetic field given by $\mathbf{B} = B\hat{\mathbf{z}}$ is applied perpendicularly to the xy plane. Calculate the eigenenergies of the particle.
41. Consider a particle with charge q and mass μ confined to move on a circle of radius a in the xy plane, but is otherwise free. A uniform and time independent magnetic field B is applied in the z direction.
- Find the eigenenergies.
 - Calculate the current J_m for each of the eigenstates of the system.
42. Calculate the expectation values $\langle L_z \rangle$ and $\langle \mathbf{L}^2 \rangle$, and the corresponding variance values $\langle (\Delta L_z)^2 \rangle$ and $\langle (\Delta \mathbf{L}^2)^2 \rangle$, for a particle having a wave function in Cartesian coordinates (x, y, z) given by

$$\psi(x, y, z) = Az \exp\left(-\frac{x^2 + y^2 + z^2}{r_0^2}\right), \quad (6.225)$$

where both A and r_0 are positive constants.

43. The Hamiltonian of a rigid rotator is given by

$$\mathcal{H} = \frac{L_z^2}{2I}, \quad (6.226)$$

where \mathbf{L} is the vector angular momentum operator, and I is a real constant. The wavefunction in spherical coordinates (θ, ϕ) is given by (θ is the polar angle, i.e. $z/r = \cos \theta$, and ϕ is the azimuthal angle, i.e. $y/x = \tan \phi$)

$$\psi(\theta, \phi) = A \cos^2 \phi, \quad (6.227)$$

where A is a normalization constant. Calculate $\langle \mathcal{H}^2 \rangle - \langle \mathcal{H} \rangle^2$.

44. The Hamiltonian of a non-isotropic rigid rotator is given by

$$\mathcal{H} = \frac{L_x^2}{2I_{xy}} + \frac{L_y^2}{2I_{xy}} + \frac{L_z^2}{2I_z}, \quad (6.228)$$

where \mathbf{L} is the vector angular momentum operator. At time $t = 0$ the state of the system is described by the wavefunction

$$\psi(\theta, \phi) = A \sin \theta \cos \phi, \quad (6.229)$$

where θ, ϕ are angles in spherical coordinates and A is a normalization constant. Calculate the expectation value $\langle L_z \rangle$ at time $t > 0$.

45. The eigenstates of the angular momentum operators \mathbf{L}^2 and L_z with $l = 1$ and $m = -1, 0, 1$ are denoted as $|1, -1\rangle$, $|1, 0\rangle$ and $|1, 1\rangle$.

- a) Write the 3×3 matrix of the operator L_x in this $l = 1$ subspace.
 b) Calculate the expectation value $\langle L_x \rangle$ for the state $\frac{1}{2} [|1, 1\rangle + \sqrt{2}|1, 0\rangle + |1, -1\rangle]$.
 c) The same as the previous section for the state $\frac{1}{\sqrt{2}} [|1, 1\rangle - |1, -1\rangle]$.
 d) Write the 3×3 matrix representation in this basis of the rotation operator at angle ϕ around the z axis.
 e) The same as in the previous section for an infinitesimal rotation with angle $d\phi$ around the x axis.
46. Consider a particle of mass m in a 3D harmonic potential

$$V(x, y, z) = \frac{1}{2} m \omega^2 (x^2 + y^2 + z^2) . \quad (6.230)$$

The state vector $|\psi\rangle$ of the particle satisfy

$$a_x |\psi\rangle = \alpha_x |\psi\rangle , \quad (6.231)$$

$$a_y |\psi\rangle = \alpha_y |\psi\rangle , \quad (6.232)$$

$$a_z |\psi\rangle = \alpha_z |\psi\rangle , \quad (6.233)$$

where α_x , α_y and α_z are complex and a_x , a_y and a_z are annihilation operators

$$a_x = \sqrt{\frac{m\omega}{2\hbar}} \left(x + \frac{ip_x}{m\omega} \right) , \quad (6.234)$$

$$a_y = \sqrt{\frac{m\omega}{2\hbar}} \left(y + \frac{ip_y}{m\omega} \right) , \quad (6.235)$$

$$a_z = \sqrt{\frac{m\omega}{2\hbar}} \left(z + \frac{ip_z}{m\omega} \right) , \quad (6.236)$$

Let \mathbf{L} be the vector operator of the orbital angular momentum.

- a) Calculate $\langle L_z \rangle$.
 b) Calculate ΔL_z .
47. A rigid rotator is prepared in a state

$$|\alpha\rangle = A (|1, 1\rangle - |1, -1\rangle) , \quad (6.237)$$

where A is a normalization constant, and where the symbol $|l, m\rangle$ denotes an angular momentum state with quantum numbers l and m . Calculate

- a) $\langle L_x \rangle$.
 b) $\langle (\Delta L_x)^2 \rangle$.
48. The Hamiltonian of a top is given by

$$\mathcal{H} = \frac{L_x^2 + L_y^2}{2I_1} + \frac{L_z^2}{2I_2} , \quad (6.238)$$

where \mathbf{L} is the angular momentum vector operator. Let $|\psi_0\rangle$ be the ground state of the system.

- a) Calculate the quantity $A_z(\phi)$, which is defined as

$$A_z(\phi) = \langle \psi_0 | \exp\left(\frac{iL_z\phi}{\hbar}\right) \mathcal{H} \exp\left(-\frac{iL_z\phi}{\hbar}\right) | \psi_0 \rangle . \quad (6.239)$$

- b) Calculate the quantity $A_x(\phi)$, which is defined as

$$A_x(\phi) = \langle \psi_0 | \exp\left(\frac{iL_x\phi}{\hbar}\right) \mathcal{H} \exp\left(-\frac{iL_x\phi}{\hbar}\right) | \psi_0 \rangle . \quad (6.240)$$

49. The wavefunction of a point particle is given by

$$\psi(\mathbf{r}) = (x + y + 2z) f(r) , \quad (6.241)$$

where $f(r)$ is a function of the radial coordinate $r = \sqrt{x^2 + y^2 + z^2}$.

- a) In a measurement of \mathbf{L}^2 what are the possible outcomes and the corresponding probabilities.
 b) The same for a measurement of L_z .
50. Consider a system comprising of two spin 1/2 particles.
 a) Show that

$$[\mathbf{S}^2, S_z] = 0 , \quad (6.242)$$

where $\mathbf{S} = \mathbf{S}_1 + \mathbf{S}_2$, $S_z = S_{1z} + S_{2z}$ and where \mathbf{S}_1 and \mathbf{S}_2 are the angular momentum vector operators of the first and second spin respectively, i.e. $\mathbf{S}_1 = (S_{1x}, S_{1y}, S_{1z})$ and $\mathbf{S}_2 = (S_{2x}, S_{2y}, S_{2z})$.

- b) Find an orthonormal basis of common eigenvectors of \mathbf{S}^2 and S_z [recall that the existence of such a basis is guaranteed by the result of the previous section $[\mathbf{S}^2, S_z] = 0$, see Eqs. (2.153) and (2.154)].
51. Consider a two spin 1/2 system.

- a) Calculate the expectation value $\langle \mathbf{S}_1 \cdot \mathbf{S}_2 \rangle$, where $\mathbf{S}_1 = (S_{1x}, S_{1y}, S_{1z})$ and $\mathbf{S}_2 = (S_{2x}, S_{2y}, S_{2z})$ are the angular momentum vector operators of the first and second spin, respectively, for the following states $|S, M\rangle$ [see Eqs. (6.688), (6.689), (6.690) and (6.691)]

$$|S = 0, M = 0\rangle = \frac{|+, -\rangle - |-, +\rangle}{\sqrt{2}} , \quad (6.243)$$

$$|S = 1, M = 1\rangle = |+, +\rangle , \quad (6.244)$$

$$|S = 1, M = 0\rangle = \frac{|+, -\rangle + |-, +\rangle}{\sqrt{2}} , \quad (6.245)$$

$$|S = 1, M = -1\rangle = |-, -\rangle . \quad (6.246)$$

- b) The operator X is defined by

$$X = \frac{1 + \frac{4}{\hbar^2} \mathbf{S}_1 \cdot \mathbf{S}_2}{2} . \quad (6.247)$$

Explain why X is commonly called the spin exchange operator.

c) Show that

$$\frac{\left(\frac{4}{\hbar^2} \mathbf{S}_1 \cdot \mathbf{S}_2\right)^2 + 2 \left(\frac{4}{\hbar^2} \mathbf{S}_1 \cdot \mathbf{S}_2\right)}{3} = 1. \quad (6.248)$$

52. A system comprising of two spin 1/2 particles is prepared in the state $|\delta\rangle$, which is given by

$$|\delta\rangle = \frac{|+, -\rangle - e^{i\delta} |-, +\rangle}{\sqrt{2}}, \quad (6.249)$$

where δ is real. Calculate the expectation values $(2/\hbar) \langle \mathbf{S}_1 \cdot \hat{\mathbf{u}}_1 \rangle$, $(2/\hbar) \langle \mathbf{S}_2 \cdot \hat{\mathbf{u}}_2 \rangle$ and $(2/\hbar)^2 \langle (\mathbf{S}_1 \cdot \hat{\mathbf{u}}_1) (\mathbf{S}_2 \cdot \hat{\mathbf{u}}_2) \rangle$, where \mathbf{S}_1 and \mathbf{S}_2 are the angular momentum vector operators of the first and second spin, repetitively, and where

$$\hat{\mathbf{u}}_1 = (\sin \theta_1 \cos \varphi_1, \sin \theta_1 \sin \varphi_1, \cos \theta_1), \quad (6.250)$$

$$\hat{\mathbf{u}}_2 = (\sin \theta_2 \cos \varphi_2, \sin \theta_2 \sin \varphi_2, \cos \theta_2), \quad (6.251)$$

are unit vectors.

53. Consider a system comprising of two spin 1/2 particles. The Hamiltonian \mathcal{H} is given by

$$\mathcal{H} = \frac{\omega}{\hbar} (\mathbf{S}_1 \cdot \mathbf{S}_2 + \eta S_{1z} S_{2z}), \quad (6.252)$$

where both ω and η are real constants, \mathbf{S}_1 and \mathbf{S}_2 are the angular momentum vector operators of the first and second spin respectively, i.e. $\mathbf{S}_1 = (S_{1x}, S_{1y}, S_{1z})$ and $\mathbf{S}_2 = (S_{2x}, S_{2y}, S_{2z})$. At time $t = 0$ the first particle is in an eigenstate of the operator S_{1z} with eigenvalue $+\hbar/2$ and the second one is in an eigenstate of the operator S_{2z} with eigenvalue $-\hbar/2$. Calculate the expectation values $\langle S_{1z} \rangle(t)$ and $\langle S_{2z} \rangle(t)$ at time $t > 0$.

54. Consider a system in a common eigenvector $|j, m\rangle$ of the angular momentum operators \mathbf{J}^2 and J_z . A measurement of the operator $J_{\hat{\mathbf{n}}} = \hat{\mathbf{n}} \cdot \mathbf{J}$ is being performed, where $\hat{\mathbf{n}} = (\cos \varphi \sin \theta, \sin \varphi \sin \theta, \cos \theta)$ is a unit vector. Calculate the expectation value $\langle J_{\hat{\mathbf{n}}} \rangle$ and the variance $\langle (\Delta J_{\hat{\mathbf{n}}})^2 \rangle$.
55. Consider a harmonic oscillator having angular resonance frequency ω and mass m . The operator $S(\xi, \varphi)$ is defined by [compare with Eq. (5.91)]

$$S(\xi, \varphi) = \exp\left(\xi \frac{e^{i\varphi} a^{\dagger 2} - e^{-i\varphi} a^2}{2}\right), \quad (6.253)$$

where both ξ and φ are real and

$$a = \sqrt{\frac{m\omega}{2\hbar}} \left(x + \frac{ip}{m\omega}\right) \quad (6.254)$$

is the annihilation operator [see Eq. (5.9)]. Show that $S(\xi, \varphi)$ can be factorized according to

$$\begin{aligned}
 S(\xi, \varphi) &= \exp\left(\frac{e^{i\varphi}}{2} a^{\dagger 2} \tanh \xi\right) \\
 &\times \exp\left(-\frac{\log(\cosh \xi)}{2} (aa^\dagger + a^\dagger a)\right) \\
 &\times \exp\left(-\frac{e^{-i\varphi}}{2} a^2 \tanh \xi\right) .
 \end{aligned} \tag{6.255}$$

56. Show that the operator $S(\xi, \varphi)$ (6.253) satisfies

$$S(\xi, 0) = Q(e^{-\xi}) , \tag{6.256}$$

where Q , which is called the squeezing operator, is given by

$$Q(\mu) = \int_{-\infty}^{\infty} \frac{dx'}{\sqrt{\mu}} |x'/\mu\rangle \langle x'| , \tag{6.257}$$

where $|x'\rangle$ is an eigenvector of the position operator x having eigenvalue x' , i.e. $x|x'\rangle = x'|x'\rangle$.

6.7 Solutions

1. By cyclic permutation of

$$R_{\hat{\mathbf{z}}} = \begin{pmatrix} \cos \phi & -\sin \phi & 0 \\ \sin \phi & \cos \phi & 0 \\ 0 & 0 & 1 \end{pmatrix} , \tag{6.258}$$

one has

$$R_{\hat{\mathbf{x}}} = \begin{pmatrix} 1 & 0 & 0 \\ 0 & \cos \phi & -\sin \phi \\ 0 & \sin \phi & \cos \phi \end{pmatrix} , \tag{6.259}$$

$$R_{\hat{\mathbf{y}}} = \begin{pmatrix} \cos \phi & 0 & \sin \phi \\ 0 & 1 & 0 \\ -\sin \phi & 0 & \cos \phi \end{pmatrix} . \tag{6.260}$$

On one hand

$$\begin{aligned}
 &1 - [R_{\hat{\mathbf{x}}}(\phi), R_{\hat{\mathbf{y}}}(\phi)] \\
 &= \begin{pmatrix} 1 & -1 + \cos^2 \phi & \sin \phi - \sin \phi \cos \phi \\ 1 - \cos^2 \phi & 1 & \sin \phi \cos \phi - \sin \phi \\ \sin \phi - \sin \phi \cos \phi & \sin \phi \cos \phi - \sin \phi & 1 \end{pmatrix} \\
 &= \begin{pmatrix} 1 & -\phi^2 & 0 \\ \phi^2 & 1 & 0 \\ 0 & 0 & 1 \end{pmatrix} + O(\phi^3) .
 \end{aligned} \tag{6.261}$$

On the other hand

$$R_{\hat{\mathbf{z}}}(\phi^2) = \begin{pmatrix} \cos \phi^2 & -\sin \phi^2 & 0 \\ \sin \phi^2 & \cos \phi^2 & 0 \\ 0 & 0 & 1 \end{pmatrix} = \begin{pmatrix} 1 & -\phi^2 & 0 \\ \phi^2 & 1 & 0 \\ 0 & 0 & 1 \end{pmatrix} + O(\phi^3) , \quad (6.262)$$

thus

$$1 - [R_{\hat{\mathbf{x}}}(\phi), R_{\hat{\mathbf{y}}}(\phi)] = R_{\hat{\mathbf{z}}}(\phi^2) + O(\phi^3) . \quad (6.263)$$

2. Using the following expressions for the 3×3 rotation matrices

$$R_{\hat{\mathbf{x}}} = \begin{pmatrix} 1 & 0 & 0 \\ 0 & \cos \theta & -\sin \theta \\ 0 & \sin \theta & \cos \theta \end{pmatrix} = 1 + K_x \theta + O(\theta^2) , \quad (6.264)$$

$$R_{\hat{\mathbf{y}}} = \begin{pmatrix} \cos \theta & 0 & \sin \theta \\ 0 & 1 & 0 \\ -\sin \theta & 0 & \cos \theta \end{pmatrix} = 1 + K_y \theta + O(\theta^2) , \quad (6.265)$$

$$R_{\hat{\mathbf{z}}} = \begin{pmatrix} \cos \theta & -\sin \theta & 0 \\ \sin \theta & \cos \theta & 0 \\ 0 & 0 & 1 \end{pmatrix} = 1 + K_z \theta + O(\theta^2) , \quad (6.266)$$

where

$$K_x = \begin{pmatrix} 0 & 0 & 0 \\ 0 & 0 & -1 \\ 0 & 1 & 0 \end{pmatrix} , \quad (6.267)$$

$$K_y = \begin{pmatrix} 0 & 0 & 1 \\ 0 & 0 & 0 \\ -1 & 0 & 0 \end{pmatrix} , \quad (6.268)$$

$$K_z = \begin{pmatrix} 0 & -1 & 0 \\ 1 & 0 & 0 \\ 0 & 0 & 0 \end{pmatrix} , \quad (6.269)$$

one finds that

$$R_{\hat{\mathbf{n}}} = \exp(i\theta K) , \quad (6.270)$$

where the matrix K is given by

$$K = i\hat{\mathbf{k}} \cdot \mathbf{K} , \quad (6.271)$$

and the unit vector $\hat{\mathbf{k}}$ is given by

$$\hat{\mathbf{k}} = \frac{\hat{\mathbf{z}} \times \hat{\mathbf{n}}}{|\hat{\mathbf{z}} \times \hat{\mathbf{n}}|} = (-\sin \varphi, \cos \varphi, 0) . \quad (6.272)$$

The following holds

$$K = i \begin{pmatrix} 0 & 0 & \cos \varphi \\ 0 & 0 & \sin \varphi \\ -\cos \varphi & -\sin \varphi & 0 \end{pmatrix}, \quad (6.273)$$

$$K^n = K^{n \bmod 2}, \quad (6.274)$$

and

$$K^2 = \begin{pmatrix} \cos^2 \varphi & \frac{\sin(2\varphi)}{2} & 0 \\ \frac{\sin(2\varphi)}{2} & \sin^2 \varphi & 0 \\ 0 & 0 & 1 \end{pmatrix}, \quad (6.275)$$

and thus

$$\begin{aligned} R_{\hat{\mathbf{n}}} &= \cos(\theta K) + i \sin(\theta K) \\ &= 1 + (\cos(\theta) - 1) K^2 + i \sin(\theta) K, \end{aligned} \quad (6.276)$$

or

$$R_{\hat{\mathbf{n}}} = \begin{pmatrix} R_{11} & R_{12} & R_{13} \\ R_{21} & R_{22} & R_{23} \\ R_{31} & R_{32} & R_{33} \end{pmatrix}, \quad (6.277)$$

where

$$R_{11} = 1 + (\cos \theta - 1) \cos^2 \varphi, \quad (6.278)$$

$$R_{22} = 1 + (\cos \theta - 1) \sin^2 \varphi, \quad (6.279)$$

$$R_{12} = R_{21} = \frac{(\cos \theta - 1) \sin(2\varphi)}{2}, \quad (6.280)$$

$$R_{31} = -R_{13} = \sin \theta \cos \varphi, \quad (6.281)$$

$$R_{32} = -R_{23} = \sin \theta \sin \varphi, \quad (6.282)$$

$$R_{33} = \cos \theta. \quad (6.283)$$

Note that

$$R_{\hat{\mathbf{n}}}^{-1} = R_{\hat{\mathbf{n}}}^T. \quad (6.284)$$

Note also that for a general 3-dimensional vector \mathbf{v} the cross product $\hat{\mathbf{n}} \times \mathbf{v}$ can be expressed as

$$\begin{aligned} \hat{\mathbf{n}} \times \mathbf{v} &= R_{\hat{\mathbf{n}}}^{-1} \begin{pmatrix} 0 & -1 & 0 \\ 1 & 0 & 0 \\ 0 & 0 & 0 \end{pmatrix} R_{\hat{\mathbf{n}}} \mathbf{v} \\ &= \begin{pmatrix} 0 & -\cos \theta & \sin \theta \sin \phi \\ \cos \theta & 0 & -\sin \theta \cos \phi \\ -\sin \theta \sin \phi & \sin \theta \cos \phi & 0 \end{pmatrix} \mathbf{v}. \end{aligned} \quad (6.285)$$

When $\varphi = 0$ the matrix $R_{\hat{\mathbf{n}}}$ becomes

$$R_{\hat{\mathbf{n}}} = \begin{pmatrix} \cos \theta & 0 & -\sin \theta \\ 0 & 1 & 0 \\ \sin \theta & 0 & \cos \theta \end{pmatrix}. \quad (6.286)$$

3. Using the identity (2.182), which is given by

$$e^L A e^{-L} = A + [L, A] + \frac{1}{2!} [L, [L, A]] + \frac{1}{3!} [L, [L, [L, A]]] + \dots, \quad (6.287)$$

and the commutation relations (6.22), which are given by

$$[J_i, J_j] = i\hbar \varepsilon_{ijk} J_k, \quad (6.288)$$

one has

$$\begin{aligned} & \exp\left(\frac{iJ_z\phi}{\hbar}\right) J_x \exp\left(-\frac{iJ_z\phi}{\hbar}\right) \\ &= J_x + \frac{i\phi}{\hbar} [J_z, J_x] + \frac{1}{2!} \left(\frac{i\phi}{\hbar}\right)^2 [J_z, [J_z, J_x]] \\ & \quad + \frac{1}{3!} \left(\frac{i\phi}{\hbar}\right)^3 [J_z, [J_z, [J_z, J_x]]] + \dots \\ &= J_x \left(1 - \frac{1}{2!} \phi^2 + \dots\right) - J_y \left(\phi - \frac{1}{3!} \phi^3 + \dots\right) \\ & \quad J_x \cos \phi - J_y \sin \phi. \end{aligned} \quad (6.289)$$

4. The components of the Pauli matrix vector $\boldsymbol{\sigma}$ are given by

$$\sigma_x = \begin{pmatrix} 0 & 1 \\ 1 & 0 \end{pmatrix}, \quad \sigma_y = \begin{pmatrix} 0 & -i \\ i & 0 \end{pmatrix}, \quad \sigma_z = \begin{pmatrix} 1 & 0 \\ 0 & -1 \end{pmatrix}. \quad (6.290)$$

a) The following holds

$$\boldsymbol{\sigma} \cdot \mathbf{a} = \begin{pmatrix} a_z & a_x - ia_y \\ a_x + ia_y & -a_z \end{pmatrix}, \quad (6.291)$$

$$\boldsymbol{\sigma} \cdot \mathbf{b} = \begin{pmatrix} b_z & b_x - ib_y \\ b_x + ib_y & -b_z \end{pmatrix}, \quad (6.292)$$

thus

$$\begin{aligned}
 (\boldsymbol{\sigma} \cdot \mathbf{a})(\boldsymbol{\sigma} \cdot \mathbf{b}) &= \begin{pmatrix} a_z b_z + (a_x - i a_y)(b_x + i b_y) & a_z(b_x - i b_y) - (a_x - i a_y)b_z \\ (a_x + i a_y)b_z - a_z(b_x + i b_y) & a_z b_z + (a_x + i a_y)(b_x - i b_y) \end{pmatrix} \\
 &= \mathbf{a} \cdot \mathbf{b} \begin{pmatrix} 1 & 0 \\ 0 & 1 \end{pmatrix} \\
 &\quad + i(a_y b_z - a_z b_y) \begin{pmatrix} 0 & 1 \\ 1 & 0 \end{pmatrix} \\
 &\quad + i(a_z b_x - a_x b_z) \begin{pmatrix} 0 & -i \\ i & 0 \end{pmatrix} \\
 &\quad + i(a_x b_y - a_y b_x) \begin{pmatrix} 1 & 0 \\ 0 & -1 \end{pmatrix} \\
 &= \mathbf{a} \cdot \mathbf{b} + i \boldsymbol{\sigma} \cdot (\mathbf{a} \times \mathbf{b}) .
 \end{aligned} \tag{6.293}$$

b) Using (a) one has

$$(\boldsymbol{\sigma} \cdot \hat{\mathbf{n}})^2 = \mathbf{1} , \tag{6.294}$$

thus with the help of the Taylor expansion of the functions $\cos(x)$ and $\sin(x)$ one finds

$$\begin{aligned}
 \exp\left(-\frac{i \boldsymbol{\sigma} \cdot \hat{\mathbf{n}} \phi}{2}\right) &= \cos\left(\frac{\boldsymbol{\sigma} \cdot \hat{\mathbf{n}} \phi}{2}\right) - i \sin\left(\frac{\boldsymbol{\sigma} \cdot \hat{\mathbf{n}} \phi}{2}\right) \\
 &= \mathbf{1} \cos \frac{\phi}{2} - i \boldsymbol{\sigma} \cdot \hat{\mathbf{n}} \sin \frac{\phi}{2} .
 \end{aligned} \tag{6.295}$$

5. In spherical coordinates the unit vectors $\hat{\mathbf{n}}$ is expressed as

$$\hat{\mathbf{n}} = (\cos \varphi \sin \theta, \sin \varphi \sin \theta, \cos \theta) , \tag{6.296}$$

thus

$$\boldsymbol{\sigma} \cdot \hat{\mathbf{n}} = \begin{pmatrix} \cos \theta & \sin \theta e^{-i \varphi} \\ \sin \theta e^{i \varphi} & -\cos \theta \end{pmatrix} . \tag{6.297}$$

The eigenvalues λ_+ and λ_- are found solving

$$\lambda_+ + \lambda_- = \text{Tr}(\boldsymbol{\sigma} \cdot \hat{\mathbf{n}}) = 0 , \tag{6.298}$$

and

$$\lambda_+ \lambda_- = \text{Det}(\boldsymbol{\sigma} \cdot \hat{\mathbf{n}}) = -1 , \tag{6.299}$$

thus

$$\lambda_{\pm} = \pm 1 . \tag{6.300}$$

The normalized eigenvectors can be chosen to be given by

$$|+\rangle \doteq \begin{pmatrix} \cos \frac{\theta}{2} \exp\left(-\frac{i\varphi}{2}\right) \\ \sin \frac{\theta}{2} \exp\left(\frac{i\varphi}{2}\right) \end{pmatrix}, \quad (6.301)$$

$$|-\rangle \doteq \begin{pmatrix} -\sin \frac{\theta}{2} \exp\left(-\frac{i\varphi}{2}\right) \\ \cos \frac{\theta}{2} \exp\left(\frac{i\varphi}{2}\right) \end{pmatrix}. \quad (6.302)$$

6. Using Eq. (6.301) one finds the probability p_+ to measure $+\hbar/2$ is given by

$$p_+ = \left| (1 \ 0) \begin{pmatrix} \cos \frac{\theta}{2} \exp\left(-\frac{i\varphi}{2}\right) \\ \sin \frac{\theta}{2} \exp\left(\frac{i\varphi}{2}\right) \end{pmatrix} \right|^2 = \cos^2 \frac{\theta}{2}, \quad (6.303)$$

and the probability p_- to measure $-\hbar/2$ is

$$p_- = 1 - p_+ = \sin^2 \frac{\theta}{2}. \quad (6.304)$$

The average value of the component of the spin along z' axis is thus

$$\frac{\hbar}{2} \left(\cos^2 \frac{\theta}{2} - \sin^2 \frac{\theta}{2} \right) = \frac{\hbar}{2} \cos \theta. \quad (6.305)$$

7. Note that $S^2 = \mathbf{a} \cdot \mathbf{a}$ [see Eq. (6.138)], and $\det S = \det(\boldsymbol{\sigma} \cdot \mathbf{a}) = -\mathbf{a} \cdot \mathbf{a}$ [see Eq. (6.137)].

- a) The following holds $S^2 = \mathbf{a} \cdot \mathbf{a} = (\mathbf{a}' + i\mathbf{a}'') \cdot (\mathbf{a}' + i\mathbf{a}'') = \mathbf{a}'^2 - \mathbf{a}''^2 + 2i\mathbf{a}' \cdot \mathbf{a}''$, thus $S^2 = 0$ provided that $\text{Re } S^2 = \mathbf{a}'^2 - \mathbf{a}''^2 = 0$ and $\text{Im } S^2 = 2\mathbf{a}' \cdot \mathbf{a}'' = 0$.
- b) The transformation $\tilde{S} = U^{-1} S U$ [see Eq. (6.141)] conserves trace $\text{Tr } \tilde{S} = \text{Tr } S$ [see Eq. (2.134)], hence \tilde{S} can be expressed as $\tilde{S} = \boldsymbol{\sigma} \cdot \tilde{\mathbf{a}}$ (recall that the Pauli matrices are all traceless). The following holds $\det \tilde{S} = \det S = -\mathbf{a} \cdot \mathbf{a}$ [see Eq. (6.141)], thus both relations (6.142) and (6.143) hold.
- c) With the help of the identity (6.138) one finds that $S^\dagger S = \mathbf{a}^* \cdot \mathbf{a} + 2\boldsymbol{\sigma} \cdot (\mathbf{a}'' \times \mathbf{a}')$, and $SS^\dagger = \mathbf{a}^* \cdot \mathbf{a} - 2\boldsymbol{\sigma} \cdot (\mathbf{a}'' \times \mathbf{a}')$. The following holds $\text{Tr}(S^\dagger S) = \text{Tr}(SS^\dagger) = 2\mathbf{a}^* \cdot \mathbf{a}$, $\det S = -\mathbf{a} \cdot \mathbf{a}$, $\det S^\dagger = -\mathbf{a}^* \cdot \mathbf{a}^*$, hence $\det(S^\dagger S) = \det(SS^\dagger) = |\mathbf{a} \cdot \mathbf{a}|^2$, and thus $S^\dagger S$ and SS^\dagger share the same eigenvectors, and the following holds

$$S^\dagger S |\mathbf{a}_\pm\rangle = (\mathbf{a}^* \cdot \mathbf{a}) (1 \pm \zeta_{\mathbf{a}}) |\mathbf{a}_\pm\rangle, \quad (6.306)$$

$$SS^\dagger |\mathbf{a}_\pm\rangle = (\mathbf{a}^* \cdot \mathbf{a}) (1 \mp \zeta_{\mathbf{a}}) |\mathbf{a}_\pm\rangle, \quad (6.307)$$

where $|\mathbf{a}_\pm\rangle$ is an eigenvector of $\boldsymbol{\sigma} \cdot (\mathbf{a}'' \times \mathbf{a}') / |\mathbf{a}'' \times \mathbf{a}'|$ with eigenvalue ± 1 , and where $\zeta_{\mathbf{a}}$ is given by [note that $\mathbf{a}^* \cdot \mathbf{a} = |\mathbf{a}'|^2 + |\mathbf{a}''|^2$, and $0 \leq \zeta_{\mathbf{a}} \leq 1$]

$$\zeta_{\mathbf{a}} = \frac{2|\mathbf{a}'' \times \mathbf{a}'|}{|\mathbf{a}'|^2 + |\mathbf{a}''|^2}. \quad (6.308)$$

- d) The following holds [note that for this case $U^{-1} = U^\dagger$, and see Eqs. (6.139) and (6.141)]

$$\begin{aligned}
 \tilde{S} &= \boldsymbol{\sigma} \cdot \mathbf{a}_{\parallel} \\
 &+ \left(\mathbf{1} \cos \frac{\phi}{2} + i \boldsymbol{\sigma} \cdot \hat{\mathbf{n}} \sin \frac{\phi}{2} \right) (\boldsymbol{\sigma} \cdot \mathbf{a}_{\perp}) \left(\mathbf{1} \cos \frac{\phi}{2} - i \boldsymbol{\sigma} \cdot \hat{\mathbf{n}} \sin \frac{\phi}{2} \right) \\
 &= (\boldsymbol{\sigma} \cdot \mathbf{a}_{\parallel}) + (\boldsymbol{\sigma} \cdot \mathbf{a}_{\perp}) \cos^2 \frac{\phi}{2} \\
 &\quad - i [\boldsymbol{\sigma} \cdot \mathbf{a}_{\perp}, \boldsymbol{\sigma} \cdot \hat{\mathbf{n}}] \sin \frac{\phi}{2} \cos \frac{\phi}{2} \\
 &\quad + ((\boldsymbol{\sigma} \cdot \hat{\mathbf{n}}) [\boldsymbol{\sigma} \cdot \mathbf{a}_{\perp}, \boldsymbol{\sigma} \cdot \hat{\mathbf{n}}] + (\boldsymbol{\sigma} \cdot \mathbf{a}_{\perp})) \sin^2 \frac{\phi}{2},
 \end{aligned} \tag{6.309}$$

thus [see Eqs. (6.138), and note that $\hat{\mathbf{n}} \cdot (\mathbf{a}_{\perp} \times \hat{\mathbf{n}}) = 0$ and $1 - 2 \sin^2(\phi/2) = \cos \phi$]

$$\tilde{S} = (\boldsymbol{\sigma} \cdot \mathbf{a}_{\parallel}) + (\boldsymbol{\sigma} \cdot \mathbf{a}_{\perp}) \cos \phi + \boldsymbol{\sigma} \cdot (\mathbf{a}_{\perp} \times \hat{\mathbf{n}}) \sin \phi, \tag{6.310}$$

hence Eq. (6.146) holds.

- e) For this case Eq. (6.146) yields [see Eq. (14.88)]

$$\begin{aligned}
 \tilde{\mathbf{a}} &= \mathbf{a}_{\parallel} + \mathbf{a}_{\perp} \cos \phi + (\mathbf{a}_{\perp} \times \hat{\mathbf{n}}) \sin \phi \\
 &= (\hat{\mathbf{n}} \cdot \hat{\mathbf{z}}) \hat{\mathbf{n}} + (\hat{\mathbf{n}} \times (\hat{\mathbf{z}} \times \hat{\mathbf{n}})) (\hat{\mathbf{z}} \cdot \hat{\mathbf{c}}) - ((\hat{\mathbf{n}} \times (\hat{\mathbf{z}} \times \hat{\mathbf{n}})) \times (\hat{\mathbf{z}} \times \hat{\mathbf{c}})) \\
 &= (\hat{\mathbf{z}} - (\hat{\mathbf{n}} \cdot \hat{\mathbf{z}}) \hat{\mathbf{n}}) (\hat{\mathbf{z}} \cdot \hat{\mathbf{c}}) - ((\hat{\mathbf{z}} - (\hat{\mathbf{n}} \cdot \hat{\mathbf{z}}) \hat{\mathbf{n}}) \times (\hat{\mathbf{z}} \times \hat{\mathbf{c}})) \\
 &= \hat{\mathbf{z}} (\hat{\mathbf{z}} \cdot \hat{\mathbf{c}}) - (\hat{\mathbf{z}} \times (\hat{\mathbf{z}} \times \hat{\mathbf{c}})) \\
 &= \hat{\mathbf{z}} (\hat{\mathbf{z}} \cdot \hat{\mathbf{c}}) - ((\hat{\mathbf{z}} \cdot \hat{\mathbf{c}}) \hat{\mathbf{z}} - \hat{\mathbf{c}}) \\
 &= \hat{\mathbf{c}}.
 \end{aligned} \tag{6.311}$$

Applying the inverse transformation (i.e. ϕ is replaced by $-\phi$) for the unit vector

$$\hat{\mathbf{c}} = \frac{\mathbf{a}'' \times \mathbf{a}'}{|\mathbf{a}'' \times \mathbf{a}'|}, \tag{6.312}$$

and for a general \mathbf{a} yields [note that for this case $\mathbf{a} \cdot \hat{\mathbf{c}} = 0$, and see Eqs. (6.146) and (14.88)]

$$\begin{aligned}
 \tilde{\mathbf{a}} &= \mathbf{a}_{\parallel} + \mathbf{a}_{\perp} \cos \phi + (\mathbf{a}_{\perp} \times \hat{\mathbf{n}}) \sin \phi \\
 &= (\hat{\mathbf{n}} \cdot \mathbf{a}) \hat{\mathbf{n}} + (\hat{\mathbf{n}} \times (\mathbf{a} \times \hat{\mathbf{n}})) (\hat{\mathbf{z}} \cdot \hat{\mathbf{c}}) + ((\hat{\mathbf{n}} \times (\mathbf{a} \times \hat{\mathbf{n}})) \times (\hat{\mathbf{z}} \times \hat{\mathbf{c}})) \\
 &= (\hat{\mathbf{n}} \cdot \mathbf{a}) \hat{\mathbf{n}} + (\mathbf{a} - (\hat{\mathbf{n}} \cdot \mathbf{a}) \hat{\mathbf{n}}) (\hat{\mathbf{z}} \cdot \hat{\mathbf{c}}) + ((\mathbf{a} - (\hat{\mathbf{n}} \cdot \mathbf{a}) \hat{\mathbf{n}}) \times (\hat{\mathbf{z}} \times \hat{\mathbf{c}})),
 \end{aligned} \tag{6.313}$$

thus [note that $\hat{\mathbf{n}} \times (\hat{\mathbf{z}} \times \hat{\mathbf{c}}) = 0$]

$$\begin{aligned}
\tilde{\mathbf{a}} &= (\hat{\mathbf{n}} \cdot \mathbf{a}) \hat{\mathbf{n}} + (\mathbf{a} - (\hat{\mathbf{n}} \cdot \mathbf{a}) \hat{\mathbf{n}}) (\hat{\mathbf{z}} \cdot \hat{\mathbf{c}}) + \mathbf{a} \times (\hat{\mathbf{z}} \times \hat{\mathbf{c}}) \\
&= (\hat{\mathbf{n}} \cdot \mathbf{a}) \hat{\mathbf{n}} + (\mathbf{a} - (\hat{\mathbf{n}} \cdot \mathbf{a}) \hat{\mathbf{n}}) (\hat{\mathbf{z}} \cdot \hat{\mathbf{c}}) + ((\mathbf{a} \cdot \hat{\mathbf{c}}) \hat{\mathbf{z}} - (\mathbf{a} \cdot \hat{\mathbf{z}}) \hat{\mathbf{c}}) \\
&= (\hat{\mathbf{n}} \cdot \mathbf{a}) (1 - \hat{\mathbf{z}} \cdot \hat{\mathbf{c}}) \hat{\mathbf{n}} + \hat{\mathbf{z}} \times (\mathbf{a} \times \hat{\mathbf{c}}) \\
&= \hat{\mathbf{z}} \times \left(\frac{(\hat{\mathbf{n}} \cdot \mathbf{a}) (1 - \hat{\mathbf{z}} \cdot \hat{\mathbf{c}})}{|\hat{\mathbf{z}} \times \hat{\mathbf{c}}|} \hat{\mathbf{c}} + \mathbf{a} \times \hat{\mathbf{c}} \right),
\end{aligned} \tag{6.314}$$

hence Eq. (6.148) holds.

8. In general, note that all smooth functions of the matrix $(\boldsymbol{\sigma} \cdot \hat{\mathbf{n}})$ commute, a fact that greatly simplifies the calculations.

a) The following holds

$$\frac{1}{1 - i\alpha (\boldsymbol{\sigma} \cdot \hat{\mathbf{n}})} = 1 + i\alpha (\boldsymbol{\sigma} \cdot \hat{\mathbf{n}}) + [i\alpha (\boldsymbol{\sigma} \cdot \hat{\mathbf{n}})]^2 + \dots, \tag{6.315}$$

thus

$$\begin{aligned}
\left(\frac{1}{1 - i\alpha (\boldsymbol{\sigma} \cdot \hat{\mathbf{n}})} \right)^\dagger &= 1 - i\alpha (\boldsymbol{\sigma} \cdot \hat{\mathbf{n}}) + [(-i)\alpha (\boldsymbol{\sigma} \cdot \hat{\mathbf{n}})]^2 + \dots \\
&= \frac{1}{1 + i\alpha (\boldsymbol{\sigma} \cdot \hat{\mathbf{n}})},
\end{aligned} \tag{6.316}$$

therefore

$$UU^\dagger = \frac{1 + i\alpha (\boldsymbol{\sigma} \cdot \hat{\mathbf{n}})}{1 - i\alpha (\boldsymbol{\sigma} \cdot \hat{\mathbf{n}})} \frac{1 - i\alpha (\boldsymbol{\sigma} \cdot \hat{\mathbf{n}})}{1 + i\alpha (\boldsymbol{\sigma} \cdot \hat{\mathbf{n}})} = 1, \tag{6.317}$$

and similarly $U^\dagger U = 1$.

b) Exploiting again the fact that all smooth functions of the matrix $(\boldsymbol{\sigma} \cdot \hat{\mathbf{n}})$ commute and using Eq. (6.294) one has

$$\begin{aligned}
\frac{dU}{d\alpha} &= i \frac{[1 - i\alpha (\boldsymbol{\sigma} \cdot \hat{\mathbf{n}})] (\boldsymbol{\sigma} \cdot \hat{\mathbf{n}}) + [1 + i\alpha (\boldsymbol{\sigma} \cdot \hat{\mathbf{n}})] (\boldsymbol{\sigma} \cdot \hat{\mathbf{n}})}{[1 - i\alpha (\boldsymbol{\sigma} \cdot \hat{\mathbf{n}})]^2} \\
&= i \frac{2 (\boldsymbol{\sigma} \cdot \hat{\mathbf{n}})}{[1 - i\alpha (\boldsymbol{\sigma} \cdot \hat{\mathbf{n}})]^2} \\
&= i \frac{2 (\boldsymbol{\sigma} \cdot \hat{\mathbf{n}})}{[1 - i\alpha (\boldsymbol{\sigma} \cdot \hat{\mathbf{n}})] [1 + i\alpha (\boldsymbol{\sigma} \cdot \hat{\mathbf{n}})]} \frac{1 + i\alpha (\boldsymbol{\sigma} \cdot \hat{\mathbf{n}})}{1 - i\alpha (\boldsymbol{\sigma} \cdot \hat{\mathbf{n}})} \\
&= \frac{2i (\boldsymbol{\sigma} \cdot \hat{\mathbf{n}})}{1 + \alpha^2} U.
\end{aligned} \tag{6.318}$$

c) By integration one has

$$\begin{aligned}
U &= U_0 \exp \left(2i (\boldsymbol{\sigma} \cdot \hat{\mathbf{n}}) \int_0^\alpha \frac{d\alpha'}{1 + \alpha'^2} \right) \\
&= U_0 \exp (2i (\boldsymbol{\sigma} \cdot \hat{\mathbf{n}}) \tan^{-1} \alpha),
\end{aligned} \tag{6.319}$$

where U_0 is the matrix U at $\alpha = 0$. With the help of Eq. (6.139) one thus finds that

$$U = U_0 [1 \cos(2 \tan^{-1} \alpha) + i \boldsymbol{\sigma} \cdot \hat{\mathbf{n}} \sin(2 \tan^{-1} \alpha)] , \quad (6.320)$$

Using the identities

$$\cos(2 \tan^{-1} \alpha) = \frac{1 - \alpha^2}{1 + \alpha^2} , \quad (6.321)$$

$$\sin(2 \tan^{-1} \alpha) = \frac{2\alpha}{1 + \alpha^2} , \quad (6.322)$$

and assuming $U_0 = 1$ one finds that

$$U = \frac{1 - \alpha^2}{1 + \alpha^2} + i \boldsymbol{\sigma} \cdot \hat{\mathbf{n}} \frac{2\alpha}{1 + \alpha^2} . \quad (6.323)$$

9. With the help of Eq. (6.138) one finds that

$$\Sigma(K_a) \Sigma(K_b) = \Sigma(K_{ab}) , \quad (6.324)$$

where $K_a = (k_{0a}, \mathbf{k}_a)$, $K_b = (k_{0b}, \mathbf{k}_b)$ and

$$K_{ab} = (k_{0a}k_{0b} + \mathbf{k}_a \cdot \mathbf{k}_b, k_{0a}\mathbf{k}_b + k_{0b}\mathbf{k}_a + i(\mathbf{k}_a \times \mathbf{k}_b)) . \quad (6.325)$$

For any non-negative integer n the vector K_n , which is defined by the relation

$$(\Sigma(K))^n = \Sigma(K_n) , \quad (6.326)$$

is expressed as [see Eq. (6.324)]

$$K_n = (a_n, b_n \mathbf{k}) . \quad (6.327)$$

The following holds $a_1 = k_0$, $b_1 = k$, where $k = |\mathbf{k}|$ [see Eq. (6.158)], and [see Eq. (6.324)]

$$a_n = k_0 a_{n-1} + k^2 b_{n-1} , \quad (6.328)$$

$$b_n = a_{n-1} + k_0 b_{n-1} , \quad (6.329)$$

or in a matrix form

$$\begin{pmatrix} a_n \\ b_n \end{pmatrix} = \begin{pmatrix} k_0 & k^2 \\ 1 & k_0 \end{pmatrix} \begin{pmatrix} a_{n-1} \\ b_{n-1} \end{pmatrix} , \quad (6.330)$$

hence K_n is given by (can be proved by induction)

$$K_n = \left(\frac{(k_0 + k)^n + (k_0 - k)^n}{2}, \frac{(k_0 + k)^n - (k_0 - k)^n}{2} \frac{\mathbf{k}}{k} \right) . \quad (6.331)$$

The Taylor expansion of $f(\Sigma(K))$ can be evaluated with the help of Eq. (6.331), hence $f(\Sigma(K)) = \Sigma(K_f)$, where

$$K_{\mathbf{f}} = \left(f_+, f_- \frac{\mathbf{k}}{k} \right), \quad (6.332)$$

and where

$$f_{\pm} = \frac{f(k_0 + k) \pm f(k_0 - k)}{2}. \quad (6.333)$$

10. The left hand side of Eq. (6.160) can be expressed as [see Eq. (6.139)]

$$\begin{aligned} \exp\left(\theta \frac{\sigma_- e^{i\varphi} - \sigma_+ e^{-i\varphi}}{2}\right) &= \exp\left(-i\theta \frac{\boldsymbol{\sigma} \cdot (-\sin\varphi, \cos\varphi, -)}{2}\right) \\ &= \mathbf{1} \cos \frac{\theta}{2} - i\boldsymbol{\sigma} \cdot (-\sin\varphi, \cos\varphi, -) \sin \frac{\theta}{2} \\ &= \begin{pmatrix} \cos \frac{\theta}{2} & -e^{-i\varphi} \sin \frac{\theta}{2} \\ e^{i\varphi} \sin \frac{\theta}{2} & \cos \frac{\theta}{2} \end{pmatrix}, \end{aligned} \quad (6.334)$$

and the right hand side of Eq. (6.160) can be expressed as (note that $\sigma_+^2 = \sigma_-^2 = 0$)

$$\begin{aligned} &e^{e^{i\varphi} \tan \frac{\theta}{2} \sigma_-} e^{-\log(1+\tan^2 \frac{\theta}{2}) \sigma_z} e^{-e^{-i\varphi} \tan \frac{\theta}{2} \sigma_+} \\ &= \begin{pmatrix} 1 & 0 \\ e^{i\varphi} \tan \frac{\theta}{2} & 1 \end{pmatrix} \begin{pmatrix} e^{-\frac{1}{2} \log(1+\tan^2 \frac{\theta}{2})} & 0 \\ 0 & e^{\frac{1}{2} \log(1+\tan^2 \frac{\theta}{2})} \end{pmatrix} \begin{pmatrix} 1 & -e^{-i\varphi} \tan \frac{\theta}{2} \\ 0 & 1 \end{pmatrix} \\ &= \begin{pmatrix} \cos \frac{\theta}{2} & -e^{-i\varphi} \sin \frac{\theta}{2} \\ e^{i\varphi} \sin \frac{\theta}{2} & \cos \frac{\theta}{2} \end{pmatrix}, \end{aligned} \quad (6.335)$$

hence Eq. (6.160) holds. Similarly, with the help of Eq. (6.139) one finds that

$$\begin{aligned} &\exp\left(-\frac{i\varphi\sigma_z}{2}\right) \exp\left(-\frac{i\theta\sigma_y}{2}\right) \exp\left(\frac{i\varphi\sigma_z}{2}\right) \\ &= \begin{pmatrix} e^{-\frac{i\varphi}{2}} & 0 \\ 0 & e^{\frac{i\varphi}{2}} \end{pmatrix} \begin{pmatrix} \cos \frac{\theta}{2} & -\sin \frac{\theta}{2} \\ \sin \frac{\theta}{2} & \cos \frac{\theta}{2} \end{pmatrix} \begin{pmatrix} e^{\frac{i\varphi}{2}} & 0 \\ 0 & e^{-\frac{i\varphi}{2}} \end{pmatrix} \\ &= \begin{pmatrix} \cos \frac{\theta}{2} & -e^{-i\varphi} \sin \frac{\theta}{2} \\ e^{i\varphi} \sin \frac{\theta}{2} & \cos \frac{\theta}{2} \end{pmatrix}, \end{aligned} \quad (6.336)$$

hence Eq. (6.161) holds. By expressing the relations (6.160) and (6.161) in terms of the spin angular momentum operator \mathbf{S} [see Eq. (6.77)] one obtains Eqs. (6.164) and (6.165). Since the derivations only uses the commutation relations $[S_i, S_j] = i\hbar\varepsilon_{ijk}S_k$ (6.22) (the Pauli matrices σ_x, σ_y and σ_z satisfy the commutation relations $[\sigma_i, \sigma_j] = 2i\varepsilon_{ijk}\sigma_k$), Eqs. (6.164) and (6.165) are both applicable for a general spin angular momentum operator \mathbf{S} [compare with the derivation of Eq. (6.255)].

11. With the help of Eq. (4.38) one finds that

$$\frac{d\langle A_1 \rangle}{dt} = -\omega \langle A_2 \rangle, \quad (6.337)$$

$$\frac{d\langle A_2 \rangle}{dt} = \omega \langle A_1 \rangle, \quad (6.338)$$

or in a matrix form

$$\frac{d}{dt} \begin{pmatrix} \langle A_1 \rangle \\ \langle A_2 \rangle \end{pmatrix} = -i\omega\sigma \begin{pmatrix} \langle A_1 \rangle \\ \langle A_2 \rangle \end{pmatrix}, \quad (6.339)$$

where [compare with Eq. (6.76)]

$$\sigma = \begin{pmatrix} 0 & -i \\ i & 0 \end{pmatrix}. \quad (6.340)$$

The solution is given by

$$\begin{pmatrix} \langle A_1 \rangle(t) \\ \langle A_2 \rangle(t) \end{pmatrix} = \exp(-i\omega\sigma) \begin{pmatrix} \langle A_1 \rangle(t=0) \\ \langle A_2 \rangle(t=0) \end{pmatrix}. \quad (6.341)$$

thus [see Eq. (6.139)]

$$\begin{pmatrix} \langle A_1 \rangle(t) \\ \langle A_2 \rangle(t) \end{pmatrix} = \begin{pmatrix} \cos(\omega t) & -\sin(\omega t) \\ \sin(\omega t) & \cos(\omega t) \end{pmatrix} \begin{pmatrix} \langle A_1 \rangle(t=0) \\ \langle A_2 \rangle(t=0) \end{pmatrix}. \quad (6.342)$$

12. The wavefunction $\psi_z(\theta, \phi)$ can be chosen to be $Y_1^0(\theta, \phi)$ [see Eqs. (6.131) and (6.132)]

$$\psi_z(\theta, \phi) = Y_1^0(\theta, \phi) = \sqrt{\frac{3}{4\pi}} \cos\theta = \sqrt{\frac{3}{4\pi}} \frac{z}{r}, \quad (6.343)$$

and similarly the wavefunctions $\psi_x(\theta, \phi)$ and $\psi_y(\theta, \phi)$ can be chosen to be

$$\psi_x(\theta, \phi) = \sqrt{\frac{3}{4\pi}} \frac{x}{r} = \frac{-Y_1^{+1}(\theta, \phi) + Y_1^{-1}(\theta, \phi)}{\sqrt{2}}, \quad (6.344)$$

$$\psi_y(\theta, \phi) = \sqrt{\frac{3}{4\pi}} \frac{y}{r} = i \frac{Y_1^{+1}(\theta, \phi) + Y_1^{-1}(\theta, \phi)}{\sqrt{2}}. \quad (6.345)$$

Orthogonality, for examples between $\psi_x(\theta, \phi)$ and $\psi_y(\theta, \phi)$, is checked by

$$\begin{aligned} & \int_{-1}^1 d(\cos\theta) \int_0^{2\pi} d\varphi \psi_x(\theta, \phi) \psi_y^*(\theta, \phi) \\ &= \frac{3}{4\pi} \int_{-1}^1 d(\cos\theta) \int_0^{2\pi} d\varphi (\sin\theta \cos\varphi) (\sin\theta \sin\varphi) \\ &= 0. \end{aligned} \quad (6.346)$$

13. The vector $|\hat{\mathbf{n}}\rangle$, which is given by

$$|\hat{\mathbf{n}}\rangle \doteq \begin{pmatrix} \cos^2\left(\frac{\theta}{2}\right) e^{-i\varphi} \\ \frac{\sin\theta}{\sqrt{2}} \\ \sin^2\left(\frac{\theta}{2}\right) e^{i\varphi} \end{pmatrix}, \quad (6.347)$$

is a normalized eigenvector of $\hat{\mathbf{n}} \cdot \mathbf{S}$, which is given by [see Eqs. (9.240), (9.242) and (9.243)]

$$\frac{\hat{\mathbf{n}} \cdot \mathbf{S}}{\hbar} \doteq \begin{pmatrix} \cos\theta & \frac{\sin\theta e^{-i\varphi}}{\sqrt{2}} & 0 \\ \frac{\sin\theta e^{i\varphi}}{\sqrt{2}} & 0 & \frac{\sin\theta e^{-i\varphi}}{\sqrt{2}} \\ 0 & \frac{\sin\theta e^{i\varphi}}{\sqrt{2}} & -\cos\theta \end{pmatrix}, \quad (6.348)$$

where $\hat{\mathbf{n}} = (\sin\theta \cos\varphi, \sin\theta \sin\varphi, \cos\theta)$ is a unit vector, with eigenvalue \hbar . Using the relations [see Eqs. (9.240), (9.242) and (9.243)]

$$\frac{\langle \hat{\mathbf{n}} | S_x | \hat{\mathbf{n}} \rangle}{\hbar} = \hat{\mathbf{n}} \cdot \hat{\mathbf{x}}, \quad (6.349)$$

$$\frac{\langle \hat{\mathbf{n}} | S_y | \hat{\mathbf{n}} \rangle}{\hbar} = \hat{\mathbf{n}} \cdot \hat{\mathbf{y}}, \quad (6.350)$$

$$\frac{\langle \hat{\mathbf{n}} | S_z | \hat{\mathbf{n}} \rangle}{\hbar} = \hat{\mathbf{n}} \cdot \hat{\mathbf{z}}, \quad (6.351)$$

and

$$\frac{\langle \hat{\mathbf{n}} | S_x^2 | \hat{\mathbf{n}} \rangle}{\hbar^2} = \frac{1 + (\hat{\mathbf{n}} \cdot \hat{\mathbf{x}})^2}{2}, \quad (6.352)$$

$$\frac{\langle \hat{\mathbf{n}} | S_y^2 | \hat{\mathbf{n}} \rangle}{\hbar^2} = \frac{1 + (\hat{\mathbf{n}} \cdot \hat{\mathbf{y}})^2}{2}, \quad (6.353)$$

$$\frac{\langle \hat{\mathbf{n}} | S_z^2 | \hat{\mathbf{n}} \rangle}{\hbar^2} = \frac{1 + (\hat{\mathbf{n}} \cdot \hat{\mathbf{z}})^2}{2}, \quad (6.354)$$

one finds that

$$\frac{E(\hat{\mathbf{n}})}{\hbar} = -\boldsymbol{\omega} \cdot \hat{\mathbf{n}} + \omega_A \frac{\text{Tr } M_N + \hat{\mathbf{n}}^T M_N \hat{\mathbf{n}}}{2}. \quad (6.355)$$

14. The following holds [see Eqs. (6.169) and (6.170)]

$$A^2 |\alpha_1\rangle = |z|^2 |\alpha_1\rangle, \quad (6.356)$$

$$A^2 |\alpha_2\rangle = |z|^2 |\alpha_2\rangle, \quad (6.357)$$

thus both $|\alpha_1\rangle$ and $|\alpha_2\rangle$ are eigenvectors of A^2 with the same eigenvalue $|z|^2$. Since $|\alpha_1\rangle$ and $|\alpha_2\rangle$ are assumed to be independent one concludes that $A^2/|z|^2$ is the identity operator. Thus, the only possible eigenvalues of A are $|z|$ and $-|z|$. As can be seen from the relations (6.169) and (6.170), and from the assumption that $|\alpha_1\rangle$ and $|\alpha_2\rangle$ are independent, the

operator A cannot be proportional to the identity operator (i.e. is must have two different eigenvalues). Thus, the eigenvalues of A are $|z|$ and $-|z|$. Alternatively, since $|\alpha_1\rangle$ and $|\alpha_2\rangle$ are assumed to be independent, any given vector $|\alpha\rangle$ can be expressed as

$$|\alpha\rangle = c_1 |\alpha_1\rangle + c_2 |\alpha_2\rangle, \quad (6.358)$$

where $c_1, c_2 \in \mathcal{C}$. The condition that $|\alpha\rangle$ is an eigenvector of A with an eigenvalue λ reads

$$A|\alpha\rangle = \lambda|\alpha\rangle, \quad (6.359)$$

thus [see Eqs. (6.169) and (6.170)]

$$(c_1 z - \lambda c_2) |\alpha_2\rangle + (c_2 z^* - \lambda c_1) |\alpha_1\rangle = 0. \quad (6.360)$$

Nontrivial solution for the coefficients c_1 and c_2 is possible provided that

$$0 = \det \begin{pmatrix} -\lambda & z^* \\ z & -\lambda \end{pmatrix}, \quad (6.361)$$

thus $\lambda = \pm |z|$.

15. In terms of Pauli matrices

$$\mathcal{H} \doteq E_a \sigma_0 + \Delta \sigma_x + E_d \sigma_z, \quad (6.362)$$

where

$$E_a = \frac{E_L + E_R}{2}, E_d = \frac{E_L - E_R}{2}, \quad (6.363)$$

and

$$\sigma_0 = \begin{pmatrix} 1 & 0 \\ 0 & 1 \end{pmatrix}, \sigma_x = \begin{pmatrix} 0 & 1 \\ 1 & 0 \end{pmatrix}, \sigma_z = \begin{pmatrix} 1 & 0 \\ 0 & -1 \end{pmatrix}. \quad (6.364)$$

Using Eq. (6.139), which is given by

$$\exp\left(-\frac{i\boldsymbol{\sigma} \cdot \hat{\mathbf{n}}\phi}{2}\right) = \cos \frac{\phi}{2} - i\boldsymbol{\sigma} \cdot \hat{\mathbf{n}} \sin \frac{\phi}{2}, \quad (6.365)$$

the time evolution operator $u(t)$ can be calculated

$$\begin{aligned} u(t) &= \exp\left(-\frac{i\mathcal{H}t}{\hbar}\right) \\ &= \exp\left(-\frac{iE_a\sigma_0 t}{\hbar}\right) \exp\left(-\frac{i(\Delta\sigma_x + E_d\sigma_z)t}{\hbar}\right) \\ &= \exp\left(-\frac{iE_a t}{\hbar}\right) \exp\left(-\frac{i\boldsymbol{\sigma} \cdot \hat{\mathbf{n}}\sqrt{\Delta^2 + E_d^2}t}{\hbar}\right), \end{aligned} \quad (6.366)$$

where

$$\boldsymbol{\sigma} \cdot \hat{\mathbf{n}} = \boldsymbol{\sigma} \cdot \frac{(\Delta, 0, E_d)}{\sqrt{\Delta^2 + E_d^2}}, \quad (6.367)$$

thus

$$u(t) = \exp\left(-\frac{iE_a t}{\hbar}\right) \left(\cos \frac{\sqrt{\Delta^2 + E_d^2} t}{\hbar} - i \frac{\Delta \sigma_x + E_d \sigma_z}{\sqrt{\Delta^2 + E_d^2}} \sin \frac{t \sqrt{\Delta^2 + E_d^2}}{\hbar} \right). \quad (6.368)$$

The probability $p_R(t)$ is thus given by

$$\begin{aligned} p_R(t) &= |\langle R | u(t) | \psi(t=0) \rangle|^2 \\ &= |\langle R | u(t) | L \rangle|^2 \\ &= \frac{\Delta^2}{\Delta^2 + \left(\frac{E_L - E_R}{2}\right)^2} \sin^2 \frac{t \sqrt{\Delta^2 + \left(\frac{E_L - E_R}{2}\right)^2}}{\hbar}. \end{aligned} \quad (6.369)$$

16. The Hamiltonian is given by

$$\mathcal{H} = \omega_0 S_z + \omega_1 (\cos(\omega t) S_x + \sin(\omega t) S_y), \quad (6.370)$$

where

$$\omega_0 = \frac{|e| B_0}{m_e c}, \quad (6.371)$$

$$\omega_1 = \frac{|e| B_1}{m_e c}. \quad (6.372)$$

The matrix representation in the basis $\{|+\rangle, |-\rangle\}$ (where $|+\rangle = |+\hat{\mathbf{z}}\rangle$ and $|-\rangle = |-\hat{\mathbf{z}}\rangle$) is found using Eqs. (6.70), (6.75) and (6.76)

$$\mathcal{H} = \frac{\hbar}{2} \begin{pmatrix} \omega_0 & \omega_1 \exp(-i\omega t) \\ \omega_1 \exp(i\omega t) & -\omega_0 \end{pmatrix}. \quad (6.373)$$

The state vector of the system $|\alpha\rangle(t)$ is expressed as $|\alpha\rangle(t) = a_+(t)|+\rangle + a_-(t)|-\rangle$. Consider a general unitary transformation $\bar{a} = U\bar{b}$, where $\bar{a} = (a_+, a_-)^T$ and $\bar{b} = (b_+, b_-)^T$. Under this transformation the Schrödinger equation $i\hbar(d\bar{a}/dt) = \mathcal{H}\bar{a}$ is transformed into

$$i\hbar \frac{d\bar{b}}{dt} = \mathcal{H}' \bar{b}, \quad (6.374)$$

where the transformed Hamiltonian \mathcal{H}' is given by

$$\hbar^{-1} \mathcal{H}' = -iU^\dagger \frac{dU}{dt} + \hbar^{-1} U^\dagger \mathcal{H} U. \quad (6.375)$$

For the current case U is chosen to be given by

$$U = \begin{pmatrix} e^{-\frac{i\omega t}{2}} & 0 \\ 0 & e^{\frac{i\omega t}{2}} \end{pmatrix}. \quad (6.376)$$

For this case Eq. (6.374) yields [see Eqs. (6.373) and (6.375)]

$$i \begin{pmatrix} \dot{b}_+ \\ \dot{b}_- \end{pmatrix} = \frac{\Omega}{2} \begin{pmatrix} b_+ \\ b_- \end{pmatrix}, \quad (6.377)$$

where

$$\Omega = \begin{pmatrix} \Delta_\omega & \omega_1 \\ \omega_1 & -\Delta_\omega \end{pmatrix} = \Delta_\omega \sigma_z + \omega_1 \sigma_x, \quad (6.378)$$

and

$$\Delta_\omega = \omega_0 - \omega. \quad (6.379)$$

At time $t = 0$

$$\begin{pmatrix} b_+(0) \\ b_-(0) \end{pmatrix} = \begin{pmatrix} 1 \\ 0 \end{pmatrix}. \quad (6.380)$$

The time evolution is found using Eq. (6.139)

$$\begin{aligned} \begin{pmatrix} b_+(t) \\ b_-(t) \end{pmatrix} &= \exp\left(-\frac{i\Omega t}{2}\right) \begin{pmatrix} b_+(0) \\ b_-(0) \end{pmatrix} \\ &= \begin{pmatrix} \cos \theta - i \frac{\Delta_\omega \sin \theta}{\omega_R} & -i \frac{\omega_1 \sin \theta}{\omega_R} \\ -i \frac{\omega_1 \sin \theta}{\omega_R} & \cos \theta + i \frac{\Delta_\omega \sin \theta}{\omega_R} \end{pmatrix} \begin{pmatrix} 1 \\ 0 \end{pmatrix}, \end{aligned} \quad (6.381)$$

where

$$\theta = \frac{\omega_R t}{2}, \quad (6.382)$$

and ω_R , which is given by

$$\omega_R = \sqrt{\omega_1^2 + \Delta_\omega^2}, \quad (6.383)$$

is the so-called angular Rabi frequency. The probability is thus given by

$$P_{+-}(t) = \frac{\omega_1^2}{\omega_R^2} \sin^2 \frac{\omega_R t}{2}. \quad (6.384)$$

17. The following holds [see Eq. (6.177)]

$$\begin{aligned}
\frac{H'}{\hbar} &= \begin{pmatrix} 0 & \omega_{12} e^{i \int_0^t dt' (\omega_{11}(t') - \omega_{22}(t'))} \\ \omega_{21} e^{-i \int_0^t dt' (\omega_{11}(t') - \omega_{22}(t'))} & 0 \end{pmatrix} \\
&= \begin{pmatrix} 0 & \frac{\Omega_{T1} e^{-i \Omega_T t} e^{i \int_0^t dt' (\Omega_0 - \Omega_{L1} \cos(\Omega_L t'))}}{2} \\ \frac{\Omega_{T1} e^{i \Omega_T t} e^{-i \int_0^t dt' (\Omega_0 - \Omega_{L1} \cos(\Omega_L t'))}}{2} & 0 \end{pmatrix} \\
&= \begin{pmatrix} 0 & \frac{\Omega_{T1} e^{i \left(\Omega_0 t - \Omega_T t - \frac{\Omega_{L1}}{\Omega_L} \sin(\Omega_L t) \right)}}{2} \\ \frac{\Omega_{T1} e^{-i \left(\Omega_0 t - \Omega_T t - \frac{\Omega_{L1}}{\Omega_L} \sin(\Omega_L t) \right)}}{2} & 0 \end{pmatrix}.
\end{aligned} \tag{6.385}$$

With the help of the Jacobi-Anger expansion (6.417) one finds that

$$e^{i \left(\Omega_0 t - \Omega_T t - \frac{\Omega_{L1}}{\Omega_L} \sin(\Omega_L t) \right)} = \sum_{l=-\infty}^{\infty} J_l \left(\frac{\Omega_{L1}}{\Omega_L} \right) e^{i(\Omega_0 - \Omega_T - l\Omega_L)t}, \tag{6.386}$$

where $J_l(z)$ is the l 'th Bessel function of the first kind. Frequency mixing, between the transverse driving at angular frequency Ω_T and longitudinal driving at angular frequency Ω_L , gives rise to a resonance in the region where $|\Omega_d|$ is small, where $\Omega_d = \Omega_0 - \Omega_T - l\Omega_L$ is the detuning angular frequency of the l 'th frequency mixing resonance. When off resonance terms in the sum are disregarded, H' becomes

$$\frac{H'}{\hbar} = \begin{pmatrix} 0 & \frac{\Omega_{T1} J_l \left(\frac{\Omega_{L1}}{\Omega_L} \right) e^{i(\Omega_0 - \Omega_T - l\Omega_L)t}}{2} \\ \frac{\Omega_{T1} J_l \left(\frac{\Omega_{L1}}{\Omega_L} \right) e^{-i(\Omega_0 - \Omega_T - l\Omega_L)t}}{2} & 0 \end{pmatrix}. \tag{6.387}$$

A second unitary transformation [see Eq. (6.375)]

$$\hbar^{-1} H'' = -i\mathcal{U}^\dagger (d\mathcal{U}/dt) + \mathcal{U}^\dagger \hbar^{-1} H' \mathcal{U}, \tag{6.388}$$

with the unitary matrix

$$\mathcal{U} = \begin{pmatrix} e^{\frac{i\Omega_d t}{2}} & 0 \\ 0 & e^{-\frac{i\Omega_d t}{2}} \end{pmatrix}, \tag{6.389}$$

yields a time independent Hamiltonian H'' given by [compare with Eq. (6.378)]

$$\frac{H''}{\hbar} = \begin{pmatrix} \frac{\Omega_d}{2} & \frac{\Omega_{T1} J_l \left(\frac{\Omega_{L1}}{\Omega_L} \right)}{2} \\ \frac{\Omega_{T1} J_l \left(\frac{\Omega_{L1}}{\Omega_L} \right)}{2} & -\frac{\Omega_d}{2} \end{pmatrix}. \tag{6.390}$$

18. The state vector of the system $|\alpha\rangle(t)$ is expressed as $|\alpha\rangle(t) = a_+(t)|+\rangle + a_-(t)|-\rangle$, the Hamiltonian is given by [compare with Eq. (6.370)]

$$\mathcal{H} = \omega_0 S_z + \sum_{n \neq 0} \frac{\omega_n}{2} (e^{in\omega t} S_- + e^{-in\omega t} S_+) , \quad (6.391)$$

and thus the Schrödinger equation reads

$$i \frac{d\bar{a}}{dt} = \frac{1}{2} \begin{pmatrix} \omega_0 & \sum_{n \neq 0} \omega_n e^{-in\omega t} \\ \sum_{n \neq 0} \omega_n e^{in\omega t} & -\omega_0 \end{pmatrix} \bar{a} , \quad (6.392)$$

where $\bar{a} = (a_+, a_-)^T$. The unitary transformation $\bar{a} = U\bar{b}$, where U is given by [compare with Eq. (6.376)]

$$U = \begin{pmatrix} e^{-\frac{i\omega t}{2}} & 0 \\ 0 & e^{\frac{i\omega t}{2}} \end{pmatrix} , \quad (6.393)$$

leads to

$$i \frac{d\bar{b}}{dt} = \frac{(\Omega + \Omega_b)}{2} \bar{b} , \quad (6.394)$$

where

$$\Omega = \begin{pmatrix} \Delta_\omega & \omega_1 \\ \omega_1 & -\Delta_\omega \end{pmatrix} , \quad (6.395)$$

$$\Omega_b = \begin{pmatrix} 0 & \eta^* \\ \eta & 0 \end{pmatrix} , \quad (6.396)$$

and where

$$\eta = \sum_{n \neq 0, 1} \omega_n e^{i(n-1)\omega t} , \quad (6.397)$$

$$\Delta_\omega = \omega_0 - \omega . \quad (6.398)$$

Consider the transformation

$$\bar{c} = (1 + iA_b) \bar{b} , \quad (6.399)$$

where

$$A_b = \frac{1}{2} \begin{pmatrix} 0 & \xi^* \\ \xi & 0 \end{pmatrix} , \quad (6.400)$$

and where

$$\xi = \sum_{n \neq 0, 1} \frac{\omega_n e^{i(n-1)\omega t}}{i(n-1)\omega} . \quad (6.401)$$

Note that the following holds

$$\Omega_b = 2 \frac{dA_b}{dt} . \quad (6.402)$$

Substituting into Eq. (6.394) yields

$$i \frac{d \left((1 + iA_b)^{-1} \bar{c} \right)}{dt} = \left(\frac{\Omega}{2} + \frac{dA_b}{dt} \right) (1 + iA_b)^{-1} \bar{c} . \quad (6.403)$$

Multiplying from the left by $(1 + iA_b)$ leads to [the identity $f (df^{-1}/dt) = - (df/dt) f^{-1}$ for $f = 1 + iA_b$ is being employed]

$$i \frac{d\bar{c}}{dt} = \frac{\Omega_e}{2} \bar{c} , \quad (6.404)$$

where

$$\Omega_e = \left((1 + iA_b) \Omega + 2iA_b \frac{dA_b}{dt} \right) (1 + iA_b)^{-1} . \quad (6.405)$$

In the so-called rotating wave approximation the matrix Ω_e is replaced by its time-averaged value $\langle \Omega_e \rangle_t$, which is defined by

$$\langle \Omega_e \rangle_t = \lim_{T \rightarrow \infty} \int_0^T dt \Omega_e(t) . \quad (6.406)$$

Since Ω is a constant matrix and A_b is time periodic

$$\langle \Omega_e \rangle_t = \Omega + 2i \left\langle A_b \frac{dA_b}{dt} \right\rangle_t , \quad (6.407)$$

thus [see Eq. (6.400)]

$$\langle \Omega_e \rangle_t = \Omega + \omega_{BS} \begin{pmatrix} 1 & 0 \\ 0 & -1 \end{pmatrix} , \quad (6.408)$$

where the Bloch-Siegert angular frequency shift ω_{BS} is given by

$$\omega_{BS} = - \sum_{n \neq 0,1} \frac{|\omega_n|^2}{2(n-1)\omega} . \quad (6.409)$$

As an example, consider the case where

$$\frac{|e| \mathbf{B}(t)}{m_e c} = \omega_0 \hat{\mathbf{z}} + 2\omega_1 \cos(\omega t) \hat{\mathbf{x}} , \quad (6.410)$$

i.e. $\omega_{-1} = \omega_1$ and $\omega_n = 0$ for $n \neq 0, -1, +1$. For this case

$$\omega_{BS} = \frac{|\omega_1|^2}{4\omega_0} . \quad (6.411)$$

Note that in experiments, a magnetic field having the form given by Eq. (6.410) is far more common than a magnetic field having the form given by Eq. (6.173).

19. The Hamiltonian \mathcal{H} is given by

$$\mathcal{H} = \omega_f S_z + \omega_1 \frac{e^{-i\omega t} S_+ + e^{i\omega t} S_-}{2}, \quad (6.412)$$

where $S_{\pm} = S_x \pm iS_y$ [see Eqs. (6.32) and (6.36)]. In terms of the operators $S'_+ = \zeta(t) S_+$ and $S'_- = \zeta^*(t) S_- = S'_+\dagger$, where the phase factor $\zeta(t)$, which is chosen to be given by

$$\zeta(t) = \exp\left(-i \int_0^t dt' (\omega_f(t') + \omega_d)\right), \quad (6.413)$$

represents the transformation into a rotating frame, and where ω_d is a real constant (to be determined later), one has

$$\mathcal{H} = \omega_f S_z + \omega_1 \frac{e^{-i\omega t} \zeta^*(t) S'_+ + e^{i\omega t} \zeta(t) S'_-}{2}. \quad (6.414)$$

The Heisenberg equations of motion (4.37) generated by \mathcal{H} are given by (recall that $[S_z, S_{\pm}] = \pm \hbar S_{\pm}$ and $[S_+, S_-] = 2\hbar S_z$)

$$\frac{dS_z}{dt} = \frac{1}{i\hbar} [S_z, \mathcal{H}] + \frac{\partial S_z}{\partial t} = \frac{i\omega_1 (e^{i\omega t} \zeta(t) S'_- - e^{-i\omega t} \zeta^*(t) S'_+)}{2}, \quad (6.415)$$

and

$$\frac{dS'_{\pm}}{dt} = \frac{1}{i\hbar} [S'_{\pm}, \mathcal{H}] + \frac{\partial S'_{\pm}}{\partial t} = -i\omega_1 e^{i\omega t} \zeta(t) S_z - i\omega_d S'_{\pm}. \quad (6.416)$$

With the help of the Jacobi-Anger expansion, which is given by

$$e^{iz \sin \theta} = \sum_{n=-\infty}^{\infty} J_n(z) e^{in\theta}, \quad (6.417)$$

one finds that $\zeta(t)$ can be expressed as [see Eq. (6.180)]

$$\zeta(t) = e^{-i(\omega_{f0} + \omega_d)t} \sum_{l'=-\infty}^{\infty} J_{l'}\left(\frac{\omega_{f1}}{\omega_p}\right) e^{il'\omega_p t}, \quad (6.418)$$

where $J_l(z)$ is the l 'th Bessel function of the first kind. When $\omega + l\omega_p \simeq \omega_{f0}$ the detuning frequency ω_d is chosen to be given by $\omega_d = \omega + l\omega_p - \omega_{f0}$. For this case all the oscillatory terms with $l' \neq l$ are disregarded. In this so-called rotating wave approximation one has

$$e^{i\omega t} \zeta(t) = J_l\left(\frac{\omega_{f1}}{\omega_p}\right), \quad (6.419)$$

and thus Eqs. (6.415) and (6.416) become

$$\frac{dS_z}{dt} = \frac{i\omega_{1,\text{eff},l}(S'_- - S'_+)}{2}, \quad (6.420)$$

and

$$\frac{dS'_+}{dt} = -i\omega_{1,\text{eff},l}S_z - i\omega_d S'_+, \quad (6.421)$$

where the effective driving amplitude $\omega_{1,\text{eff},l}$ of the l 'th resonance is given by

$$\omega_{1,\text{eff},l} = J_l \left(\frac{\omega_{\text{fl}}}{\omega_{\text{p}}} \right) \omega_1. \quad (6.422)$$

- a) A time independent effective Hamiltonian \mathcal{H}_{eff} corresponding to the equations of motion (6.420) and (6.421) is given by [verify this by deriving the Heisenberg equations of motion (4.37) and note that in this approach S'_+ is treated as not having explicit time dependency]

$$\mathcal{H}_{\text{eff}} = -\omega_d S_z + \frac{\omega_{1,\text{eff},l}(S'_+ + S'_-)}{2}. \quad (6.423)$$

- b) When the magnetic field given by Eq. (6.179) is replaced by the one given by Eq. (6.181), the Hamiltonian \mathcal{H} (6.412) becomes (it is assumed that ω_1 is real)

$$\mathcal{H} = \omega_f S_z + \omega_1 \frac{(e^{i\omega t} + e^{-i\omega t})(S_+ + S_-)}{2}. \quad (6.424)$$

The matrix representation of \mathcal{H} in the basis of eigenvectors of S_z is given by

$$\hbar^{-1}\mathcal{H} = \frac{1}{2} \begin{pmatrix} \omega_f & \omega_1(e^{i\omega t} + e^{-i\omega t}) \\ \omega_1(e^{i\omega t} + e^{-i\omega t}) & -\omega_f \end{pmatrix}, \quad (6.425)$$

where $\omega_f = \omega_{f0} - \omega_{\text{fl}} \cos(\omega_{\text{p}}t)$. Under the above-discussed unitary transformation U , which has a matrix representation given by

$$U = \begin{pmatrix} \zeta^{1/2} & 0 \\ 0 & (\zeta^{1/2})^* \end{pmatrix} = \begin{pmatrix} e^{-\frac{i\theta}{2}} & 0 \\ 0 & e^{\frac{i\theta}{2}} \end{pmatrix}, \quad (6.426)$$

where

$$\theta = \int_0^t dt' (\omega_f(t') + \omega_d), \quad (6.427)$$

\mathcal{H} is transformed into the Hamiltonian \mathcal{H}' , whose matrix representation is given by [see Eq. (6.375)]

$$\hbar^{-1}\mathcal{H}' = \frac{1}{2} \begin{pmatrix} -\omega_d & \omega_1 (e^{i\omega t} + e^{-i\omega t}) \zeta^* \\ \omega_1 (e^{i\omega t} + e^{-i\omega t}) \zeta & \omega_d \end{pmatrix}. \quad (6.428)$$

At the l' th resonance, i.e. for $\omega_d = \omega + l\omega_p - \omega_{f0} = 0$, the following holds [see Eq. (6.418) and recall that it is assumed that $\omega_p = \omega$, thus at the l' th resonance $\omega_p = \omega = \omega_{f0}/(l+1)$]

$$\zeta(t) = \sum_{l'=-\infty}^{\infty} J_{l'} \left(\frac{\omega_{f1}}{\omega} \right) e^{i(l'-l-1)\omega t}, \quad (6.429)$$

and thus [see Eq. (6.428)]

$$\hbar^{-1}\mathcal{H}' = \frac{1}{2} \begin{pmatrix} 0 & \sum_{l'=-\infty}^{\infty} \omega_{l'} e^{-i(l'-l)\omega t} \\ \sum_{l'=-\infty}^{\infty} \omega_{l'} e^{i(l'-l)\omega t} & 0 \end{pmatrix}, \quad (6.430)$$

where

$$\omega_{l'} = \omega_1 \left(J_{l'} \left(\frac{\omega_{f1}}{\omega} \right) + J_{l'+2} \left(\frac{\omega_{f1}}{\omega} \right) \right). \quad (6.431)$$

With the help of Eq. (6.409) one finds that the Bloch-Siegert shift at the l' th resonance $\omega_{BS,l}$ is given by [see Eq. (6.396)]

$$\omega_{BS,l} = \sum_{l' \neq l} \frac{\omega_1^2 \left(J_{l'} \left(\frac{\omega_{f1}}{\omega} \right) + J_{l'+2} \left(\frac{\omega_{f1}}{\omega} \right) \right)^2}{2(l-l')\omega}. \quad (6.432)$$

20. The matrix representation of \mathcal{H} in the basis of spin states

$$\{|++\rangle, |-\rangle, |+-\rangle, |--\rangle\}$$

(common eigenvectors of S_z and I_z) is given by

$$\mathcal{H} \doteq \frac{\hbar}{2} \begin{pmatrix} \omega_s + \omega_n + A & \omega_1 \exp(-i\omega t) & 0 & 0 \\ \omega_1 \exp(i\omega t) & -\omega_s + \omega_n - A & 0 & 0 \\ 0 & 0 & \omega_s - \omega_n - A & \omega_1 \exp(-i\omega t) \\ 0 & 0 & \omega_1 \exp(i\omega t) & -\omega_s - \omega_n + A \end{pmatrix}. \quad (6.433)$$

Expressing the general solution as

$$|\alpha\rangle = b_{++} e^{-\frac{i\omega t}{2}} |++\rangle + b_{-+} e^{\frac{i\omega t}{2}} |-\rangle + b_{+-} e^{-\frac{i\omega t}{2}} |+-\rangle + b_{--} e^{\frac{i\omega t}{2}} |--\rangle, \quad (6.434)$$

and substituting into the Schrödinger equation $i\hbar(d/dt)|\alpha\rangle = \mathcal{H}|\alpha\rangle$ yields [compare with Eq. (6.375)]

$$i \frac{d}{dt} \bar{b} = \frac{\Omega}{2} \bar{b}, \quad (6.435)$$

where the vector of amplitudes \bar{b} is given by $\bar{b} = (b_{++}, b_{-+}, b_{+-}, b_{--})^T$, the matrix Ω can be expressed in a block form as

$$\Omega = \left(\begin{array}{c|c} \Omega_+ & 0 \\ \hline 0 & \Omega_- \end{array} \right), \quad (6.436)$$

where

$$\Omega_{\pm} = \begin{pmatrix} \Delta \pm \omega_n \pm A & \omega_1 \\ \omega_1 & -\Delta \pm \omega_n \mp A \end{pmatrix}, \quad (6.437)$$

and where the detuning Δ is given by $\Delta = \omega_s - \omega$. The following holds

$$\Omega_{\pm} = \pm \omega_n \begin{pmatrix} 1 & 0 \\ 0 & 1 \end{pmatrix} + \omega_{\pm} \begin{pmatrix} \cos \theta_{\pm} & \sin \theta_{\pm} \\ \sin \theta_{\pm} & -\cos \theta_{\pm} \end{pmatrix}, \quad (6.438)$$

where

$$\theta_{\pm} = \tan^{-1} \frac{\omega_1}{\Delta \pm A}, \quad (6.439)$$

$$\omega_{\pm} = \sqrt{(\Delta \pm A)^2 + \omega_1^2}. \quad (6.440)$$

The 2×2 blocks Ω_{\pm} can be diagonalized by applying the transformation [see Eqs. (6.301) and (6.302)]

$$U^{-1}(\theta_{\pm}) \Omega_{\pm} U(\theta_{\pm}) = \begin{pmatrix} \pm \omega_n + \omega_{\pm} & 0 \\ 0 & \pm \omega_n - \omega_{\pm} \end{pmatrix}, \quad (6.441)$$

where

$$U(\theta) = \begin{pmatrix} \cos \frac{\theta}{2} & -\sin \frac{\theta}{2} \\ \sin \frac{\theta}{2} & \cos \frac{\theta}{2} \end{pmatrix}. \quad (6.442)$$

Thus the energy eigenvectors are

$$|\alpha_1\rangle = \cos \frac{\theta_+}{2} e^{-\frac{i\omega t}{2}} |++\rangle + \sin \frac{\theta_+}{2} e^{\frac{i\omega t}{2}} |-\rangle, \quad (6.443)$$

$$|\alpha_2\rangle = -\sin \frac{\theta_+}{2} e^{-\frac{i\omega t}{2}} |++\rangle + \cos \frac{\theta_+}{2} e^{\frac{i\omega t}{2}} |-\rangle, \quad (6.444)$$

$$|\alpha_3\rangle = \cos \frac{\theta_-}{2} e^{-\frac{i\omega t}{2}} |+-\rangle + \sin \frac{\theta_-}{2} e^{\frac{i\omega t}{2}} |--\rangle, \quad (6.445)$$

$$|\alpha_4\rangle = -\sin \frac{\theta_-}{2} e^{-\frac{i\omega t}{2}} |+-\rangle + \cos \frac{\theta_-}{2} e^{\frac{i\omega t}{2}} |--\rangle, \quad (6.446)$$

and corresponding energy eigenvalues are

$$\hbar^{-1}E_1 = \frac{\omega_n + \omega_+}{2}, \quad (6.447)$$

$$\hbar^{-1}E_2 = \frac{\omega_n - \omega_+}{2}, \quad (6.448)$$

$$\hbar^{-1}E_3 = \frac{-\omega_n + \omega_-}{2}, \quad (6.449)$$

$$\hbar^{-1}E_4 = \frac{-\omega_n - \omega_-}{2}. \quad (6.450)$$

The angular frequency ω_{n+} (ω_{n-}) corresponding to the transitions $1 \longleftrightarrow 3$ ($2 \longleftrightarrow 4$) is given by

$$\omega_{n+} = \omega_n + \delta_n, \quad (6.451)$$

$$\omega_{n-} = \omega_n - \delta_n, \quad (6.452)$$

where δ_n is given by

$$\begin{aligned} \delta_n &= \frac{\omega_+ - \omega_-}{2} \\ &= \frac{\sqrt{(\Delta + A)^2 + \omega_1^2} - \sqrt{(\Delta - A)^2 + \omega_1^2}}{2} \\ &= A \frac{\sqrt{1 + \frac{\omega_R^2}{A^2} + \frac{2\Delta}{A}} - \sqrt{1 + \frac{\omega_R^2}{A^2} - \frac{2\Delta}{A}}}{2}, \end{aligned} \quad (6.453)$$

where $\omega_R = \sqrt{\omega_1^2 + \Delta^2}$ is the angular Rabi frequency [see Eq. (6.383)]. The following holds

$$\delta_n = \frac{\Delta}{\sqrt{1 + \frac{\omega_1^2}{A^2}}} + O(\Delta^3). \quad (6.454)$$

The driving-induced reduction of the splitting $\omega_{n+} - \omega_{n-} = 2\delta_n$, which is demonstrated by the above result, is commonly referred to as spin decoupling.

21. The transformation into the rotating frame reads

$$|\alpha\rangle(t) = b_+(t) \exp\left(-\frac{i\omega t}{2}\right) |+\rangle + b_-(t) \exp\left(\frac{i\omega t}{2}\right) |-\rangle. \quad (6.455)$$

For time periods where $g(t)$ is constant the time evolution is governed by Eq. (6.381). Thus at time $t = 2\tau_p + \tau_0$ one has

$$\begin{pmatrix} b_+(2\tau_p + \tau_0) \\ b_-(2\tau_p + \tau_0) \end{pmatrix} = M_p M_0 M_p \begin{pmatrix} 1 \\ 0 \end{pmatrix}, \quad (6.456)$$

where

$$M_{\text{p}} = \begin{pmatrix} \cos \theta_{\text{p}} - \frac{i\delta \sin \theta_{\text{p}}}{\sqrt{1+\delta^2}} & -\frac{i \sin \theta_{\text{p}}}{\sqrt{1+\delta^2}} \\ -\frac{i \sin \theta_{\text{p}}}{\sqrt{1+\delta^2}} & \cos \theta_{\text{p}} + \frac{i\delta \sin \theta_{\text{p}}}{\sqrt{1+\delta^2}} \end{pmatrix}, \quad (6.457)$$

$$M_0 = \begin{pmatrix} e^{-i\frac{\alpha_0}{2}} & 0 \\ 0 & e^{i\frac{\alpha_0}{2}} \end{pmatrix}, \quad (6.458)$$

and where

$$\theta_{\text{p}} = \frac{\sqrt{1+\delta^2}\alpha_{\text{p}}}{2}. \quad (6.459)$$

Thus the probability $P_{++}(2\tau_{\text{p}} + \tau_0)$ is given by

$$\begin{aligned} P_{++}(2\tau_{\text{p}} + \tau_0) &= |b_+(2\tau_{\text{p}} + \tau_0)|^2 \\ &= \left| \left(\cos \theta_{\text{p}} - \frac{i\delta \sin \theta_{\text{p}}}{\sqrt{1+\delta^2}} \right)^2 - \frac{e^{i\alpha_0} \sin^2 \theta_{\text{p}}}{1+\delta^2} \right|^2 \\ &= \left| \cos(2\theta_{\text{p}}) - \frac{i\delta \sin(2\theta_{\text{p}})}{\sqrt{1+\delta^2}} + \frac{(1-e^{i\alpha_0}) \sin^2 \theta_{\text{p}}}{1+\delta^2} \right|^2. \end{aligned} \quad (6.460)$$

For the case where $\alpha_{\text{p}} = \pi/2$ one has to lowest nonvanishing order in δ

$$P_{++}(2\tau_{\text{p}} + \tau_0) = \frac{1 - \cos \alpha_0}{2} + \delta \sin \alpha_0 + O(\delta^2). \quad (6.461)$$

Note that the probability $P_{++}(t)$ is unchanged for $t > 2\tau_{\text{p}} + \tau_0$.

22. The Schrödinger equation is given by

$$i\hbar \frac{d|\alpha\rangle}{dt} = \mathcal{H}|\alpha\rangle, \quad (6.462)$$

where

$$\mathcal{H} = \omega S_z, \quad (6.463)$$

and

$$\omega(t) = \frac{|e|B(t)}{m_e c}. \quad (6.464)$$

In the basis of the eigenvectors of S_z one has

$$|\alpha\rangle = c_+ |+\rangle + c_- |-\rangle, \quad (6.465)$$

and

$$i\hbar (\dot{c}_+ |+\rangle + \dot{c}_- |-\rangle) = \omega S_z (c_+ |+\rangle + c_- |-\rangle), \quad (6.466)$$

where

$$S_z |\pm\rangle = \pm \frac{\hbar}{2} |\pm\rangle, \quad (6.467)$$

thus one gets 2 decoupled equations

$$\dot{c}_+ = -\frac{i\omega}{2} c_+, \quad (6.468)$$

$$\dot{c}_- = \frac{i\omega}{2} c_- . \quad (6.469)$$

The solution is given by

$$\begin{aligned} c_{\pm}(t) &= c_{\pm}(0) \exp\left(\mp \frac{i}{2} \int_0^t \omega(t') dt'\right) \\ &= c_{\pm}(0) \exp\left(\mp \frac{i|e|}{2m_e c} \int_0^t B(t') dt'\right). \end{aligned} \quad (6.470)$$

23. At time $t = 0$

$$|\psi(t=0)\rangle = \frac{1}{\sqrt{2}} (|+\rangle + |-\rangle). \quad (6.471)$$

Using the result of the previous problem and the notation

$$\omega_c = \frac{eB}{mc}, \quad (6.472)$$

one finds

$$\begin{aligned} |\psi(t)\rangle &= \frac{1}{\sqrt{2}} \left[\exp\left(-\frac{i\omega_c}{2} \int_0^t dt' \cos(\omega t')\right) |+\rangle + \exp\left(\frac{i\omega_c}{2} \int_0^t dt' \cos(\omega t')\right) |-\rangle \right] \\ &= \frac{1}{\sqrt{2}} \left[\exp\left(-\frac{i\omega_c \sin \omega t}{2\omega}\right) |+\rangle + \exp\left(\frac{i\omega_c \sin \omega t}{2\omega}\right) |-\rangle \right], \end{aligned} \quad (6.473)$$

thus

$$\langle S_z \rangle(t) = \langle \psi(t) | S_z | \psi(t) \rangle = 0. \quad (6.474)$$

24. The Schrödinger equation for u is given by

$$i\hbar \frac{du}{dt} = \mathcal{H}u, \quad (6.475)$$

thus

$$\frac{du}{dt} = \frac{4i\omega S_z}{\hbar} \frac{1}{1 + (\omega t)^2} u. \quad (6.476)$$

By integration one finds

$$\begin{aligned} u(t) &= u(0) \exp\left(\frac{4i\omega S_z}{\hbar} \int_0^t \frac{dt'}{1 + (\omega t')^2}\right) \\ &= u(0) \exp\left(\frac{4iS_z}{\hbar} \tan^{-1}(\omega t)\right). \end{aligned} \quad (6.477)$$

Setting an initial condition $u(t=0) = \mathbf{1}$ yields

$$u(t) = \exp\left(\frac{4iS_z}{\hbar} \tan^{-1}(\omega t)\right). \quad (6.478)$$

The matrix elements of $u(t)$ in the basis of the eigenstates $|\pm\rangle$ of S_z are given by

$$\langle + | u(t) | + \rangle = \exp(2i \tan^{-1}(\omega t)) = \frac{1 + i\omega t}{1 - i\omega t}, \quad (6.479)$$

$$\langle - | u(t) | - \rangle = \exp(-2i \tan^{-1}(\omega t)) = \frac{1 - i\omega t}{1 + i\omega t}, \quad (6.480)$$

$$\langle + | u(t) | - \rangle = \langle - | u(t) | + \rangle = 0. \quad (6.481)$$

25. The eigenvector of $\mathbf{S} \cdot \hat{\mathbf{n}}$, where $\hat{\mathbf{n}} = (\sin \theta \cos \varphi, \sin \theta \sin \varphi, \cos \theta)$ with eigenvalue $+\hbar/2$ is given by [see Eq. (6.301)]

$$|+; \mathbf{S} \cdot \hat{\mathbf{n}}\rangle = \cos \frac{\theta}{2} e^{-i\frac{\varphi}{2}} |+\rangle + \sin \frac{\theta}{2} e^{i\frac{\varphi}{2}} |-\rangle. \quad (6.482)$$

The operator S_z is written as

$$S_z = \frac{\hbar}{2} (|+\rangle \langle +| - |-\rangle \langle -|). \quad (6.483)$$

a) Thus

$$\langle +; \mathbf{S} \cdot \hat{\mathbf{n}} | S_z | +; \mathbf{S} \cdot \hat{\mathbf{n}} \rangle = \frac{\hbar}{2} \left(\cos^2 \frac{\theta}{2} - \sin^2 \frac{\theta}{2} \right) = \frac{\hbar}{2} \cos \theta. \quad (6.484)$$

b) Since S_z^2 is the identity operator times $\hbar^2/4$ one has

$$\langle (\Delta S_z)^2 \rangle = \langle S_z^2 \rangle - \langle S_z \rangle^2 = \frac{\hbar^2}{4} (1 - \cos^2 \theta) = \frac{\hbar^2}{4} \sin^2 \theta. \quad (6.485)$$

26. We seek a unit vector $\hat{\mathbf{n}}$ such that

$$|\psi\rangle = |+; \mathbf{S} \cdot \hat{\mathbf{n}}\rangle, \quad (6.486)$$

where $|+; \mathbf{S} \cdot \hat{\mathbf{n}}\rangle$ is given by Eq. (6.301)

$$|+; \mathbf{S} \cdot \hat{\mathbf{n}}\rangle = \cos \frac{\theta_+}{2} \exp\left(-\frac{i\varphi_+}{2}\right) |+\rangle + \sin \frac{\theta_+}{2} \exp\left(\frac{i\varphi_+}{2}\right) |-\rangle, \quad (6.487)$$

thus the following hold

$$\operatorname{ctg} \frac{\theta_+}{2} = \left| \frac{\alpha}{\beta} \right|, \quad (6.488)$$

and

$$\varphi_+ = \arg(\beta) - \arg(\alpha). \quad (6.489)$$

Similarly, by requiring that

$$|\psi\rangle = |-\;; \mathbf{S} \cdot \hat{\mathbf{n}}\rangle, \quad (6.490)$$

where

$$|-\;; \mathbf{S} \cdot \hat{\mathbf{n}}\rangle = -\sin \frac{\theta_-}{2} \exp\left(-\frac{i\varphi_-}{2}\right) |+\rangle + \cos \frac{\theta_-}{2} \exp\left(\frac{i\varphi_-}{2}\right) |-\rangle, \quad (6.491)$$

one finds

$$\tan \frac{\theta_-}{2} = \left| \frac{\alpha}{\beta} \right|, \quad (6.492)$$

$$\varphi_- = \arg(\beta) - \arg(\alpha) + \pi. \quad (6.493)$$

27. The Hamiltonian at the time interval $0 < t < \tau$ is given by

$$\mathcal{H} = -\gamma B_0 (\mathbf{S} \cdot \hat{\mathbf{u}}), \quad (6.494)$$

where γ is the gyromagnetic ratio and \mathbf{S} is the angular momentum operator. The eigenvectors of $\mathbf{S} \cdot \hat{\mathbf{u}}$ with eigenvalue $\pm\hbar/2$ are given by [see Eqs. (6.301) and (6.302)]

$$|+; \mathbf{S} \cdot \hat{\mathbf{u}}\rangle = \cos \frac{\theta}{2} e^{-i\frac{\varphi}{2}} |+\rangle + \sin \frac{\theta}{2} e^{i\frac{\varphi}{2}} |-\rangle, \quad (6.495)$$

$$|-\;; \mathbf{S} \cdot \hat{\mathbf{u}}\rangle = -\sin \frac{\theta}{2} e^{-i\frac{\varphi}{2}} |+\rangle + \cos \frac{\theta}{2} e^{i\frac{\varphi}{2}} |-\rangle, \quad (6.496)$$

Thus in the time interval $0 < t < \tau$ the state vector is given by

$$\begin{aligned}
|\alpha\rangle &= |+\rangle; \mathbf{S} \cdot \hat{\mathbf{u}} \langle +; \mathbf{S} \cdot \hat{\mathbf{u}} |+\rangle \exp\left(\frac{i\gamma B_0 t}{2}\right) + |-\rangle; \mathbf{S} \cdot \hat{\mathbf{u}} \langle -; \mathbf{S} \cdot \hat{\mathbf{u}} |+\rangle \exp\left(-\frac{i\gamma B_0 t}{2}\right) \\
&= |+\rangle; \mathbf{S} \cdot \hat{\mathbf{u}} \cos\frac{\theta}{2} e^{i\frac{\varphi}{2}} \exp\left(\frac{i\gamma B_0 t}{2}\right) - |-\rangle; \mathbf{S} \cdot \hat{\mathbf{u}} \sin\frac{\theta}{2} e^{i\frac{\varphi}{2}} \exp\left(-\frac{i\gamma B_0 t}{2}\right) \\
&= e^{i\varphi} \left[\cos^2\frac{\theta}{2} \exp\left(\frac{i\gamma B_0 t}{2}\right) + \sin^2\frac{\theta}{2} \exp\left(-\frac{i\gamma B_0 t}{2}\right) \right] |+\rangle \\
&\quad + \sin\frac{\theta}{2} \cos\frac{\theta}{2} \left[\exp\left(\frac{i\gamma B_0 t}{2}\right) - \exp\left(-\frac{i\gamma B_0 t}{2}\right) \right] |-\rangle \\
&= e^{i\varphi} \left[\frac{1 + \cos\theta}{2} \exp\left(\frac{i\gamma B_0 t}{2}\right) + \frac{1 - \cos\theta}{2} \exp\left(-\frac{i\gamma B_0 t}{2}\right) \right] |+\rangle \\
&\quad + i \sin\theta \sin\left(\frac{\gamma B_0 t}{2}\right) |-\rangle \\
&= e^{i\varphi} \left[\cos\left(\frac{\gamma B_0 t}{2}\right) + i \cos\theta \sin\left(\frac{\gamma B_0 t}{2}\right) \right] |+\rangle + i \sin\theta \sin\left(\frac{\gamma B_0 t}{2}\right) |-\rangle .
\end{aligned} \tag{6.497}$$

Thus for $t > \tau$

$$P_-(t) = \sin^2\theta \sin^2\left(\frac{\gamma B_0 \tau}{2}\right). \tag{6.498}$$

An alternative solution - The Hamiltonian in the basis of $|\pm\rangle$ states is given by

$$\mathcal{H} = -\frac{\gamma B_0 \hbar}{2} (\boldsymbol{\sigma} \cdot \hat{\mathbf{u}}), \tag{6.499}$$

where $\boldsymbol{\sigma}$ is the Pauli matrix vector

$$\sigma_1 = \begin{pmatrix} 0 & 1 \\ 1 & 0 \end{pmatrix}, \sigma_2 = \begin{pmatrix} 0 & -i \\ i & 0 \end{pmatrix}, \sigma_3 = \begin{pmatrix} 1 & 0 \\ 0 & -1 \end{pmatrix}. \tag{6.500}$$

The time evolution operator is given by

$$u(t) = \exp\left(-\frac{i\mathcal{H}t}{\hbar}\right) = \exp\left[\frac{i\gamma B_0 t}{2} (\boldsymbol{\sigma} \cdot \hat{\mathbf{u}})\right]. \tag{6.501}$$

Using the identity (6.139) one finds

$$\begin{aligned}
u(t) &= I \cos\left(\frac{\gamma B_0 t}{2}\right) + i \hat{\mathbf{u}} \cdot \boldsymbol{\sigma} \sin\left(\frac{\gamma B_0 t}{2}\right) \\
&= \begin{pmatrix} \cos\left(\frac{\gamma B_0 t}{2}\right) + i \cos\theta \sin\left(\frac{\gamma B_0 t}{2}\right) & i \sin\theta e^{-i\varphi} \sin\left(\frac{\gamma B_0 t}{2}\right) \\ i \sin\theta e^{i\varphi} \sin\left(\frac{\gamma B_0 t}{2}\right) & \cos\left(\frac{\gamma B_0 t}{2}\right) - i \cos\theta \sin\left(\frac{\gamma B_0 t}{2}\right) \end{pmatrix},
\end{aligned} \tag{6.502}$$

thus for $t > \tau$

$$P_-(t) = \left| (0 \ 1) u(t) \begin{pmatrix} 1 \\ 0 \end{pmatrix} \right|^2 = \sin^2 \theta \sin^2 \left(\frac{\gamma B_0 \tau}{2} \right). \quad (6.503)$$

28. The matrix representation of the Hamiltonian in the basis of $|\pm; S_z\rangle$ states is given by

$$\mathcal{H} \doteq \frac{\hbar\omega}{2} (\hat{\mathbf{x}} \cdot \boldsymbol{\sigma}), \quad (6.504)$$

where $\boldsymbol{\sigma}$ is the Pauli matrix vector

$$\sigma_x = \begin{pmatrix} 0 & 1 \\ 1 & 0 \end{pmatrix}, \quad \sigma_y = \begin{pmatrix} 0 & -i \\ i & 0 \end{pmatrix}, \quad \sigma_z = \begin{pmatrix} 1 & 0 \\ 0 & -1 \end{pmatrix}. \quad (6.505)$$

a) The time evolution operator is given by

$$u(t) = \exp\left(-\frac{i\mathcal{H}t}{\hbar}\right) \doteq \exp\left(-\frac{i\omega t}{2} (\hat{\mathbf{x}} \cdot \boldsymbol{\sigma})\right). \quad (6.506)$$

Using the identity

$$\exp(i\mathbf{u} \cdot \boldsymbol{\sigma}) = \mathbf{1} \cos \alpha + i\hat{\mathbf{u}} \cdot \boldsymbol{\sigma} \sin \alpha, \quad (6.507)$$

where $\mathbf{u} = \alpha\hat{\mathbf{u}}$ is a three-dimensional real vector and $\hat{\mathbf{u}}$ is a three-dimensional real unit vector, one finds

$$\begin{aligned} u(t) &\doteq \mathbf{1} \cos \frac{\omega t}{2} - i\sigma_1 \sin \frac{\omega t}{2} \\ &= \begin{pmatrix} \cos \frac{\omega t}{2} & -i \sin \frac{\omega t}{2} \\ -i \sin \frac{\omega t}{2} & \cos \frac{\omega t}{2} \end{pmatrix}. \end{aligned} \quad (6.508)$$

b) Let $P_{++}(t)$ be the probability to measure $S_z = +\hbar/2$ at time $t > 0$ given that at time $t = 0$ the spin was found to have $S_z = +\hbar/2$. Similarly, $P_{--}(t)$ is the probability to measure $S_z = -\hbar/2$ at time $t > 0$ given that at time $t = 0$ the spin was found to have $S_z = -\hbar/2$. These probabilities are given by

$$P_{++}(t) = \left| (1 \ 0) u(t) \begin{pmatrix} 1 \\ 0 \end{pmatrix} \right|^2 = \cos^2 \frac{\omega t}{2}, \quad (6.509)$$

$$P_{--}(t) = \left| (0 \ 1) u(t) \begin{pmatrix} 0 \\ 1 \end{pmatrix} \right|^2 = \cos^2 \frac{\omega t}{2}. \quad (6.510)$$

Thus, assuming that the first measurement has yielded $S_z = +\hbar/2$ one finds $p_{\text{same}} = [P_{++}(\frac{T}{N})]^N$, whereas assuming that the first measurement has yielded $S_z = -\hbar/2$ one finds $p_{\text{same}} = [P_{--}(\frac{T}{N})]^N$. Thus in general independently on the result of the first measurement one has

$$p_{\text{same}} = \cos^{2N} \frac{\omega T}{2N}. \quad (6.511)$$

c) Using

$$\begin{aligned}
 p_{\text{same}} &= \exp\left(2N \log\left(\cos\frac{\omega T}{2N}\right)\right) \\
 &= \exp\left(2N \log\left(1 - \frac{1}{2}\left(\frac{\omega T}{2N}\right)^2 + O\left(\frac{1}{N}\right)^4\right)\right) \\
 &= \exp\left(-\frac{(\omega T)^2}{4N} + O\left(\frac{1}{N}\right)^3\right),
 \end{aligned} \tag{6.512}$$

one finds that

$$\lim_{N \rightarrow \infty} p_{\text{same}} = 1. \tag{6.513}$$

This somewhat surprising result is called the quantum Zeno effect or the 'watched pot never boils' effect. Note that for large N Eq. (6.512) can be rewritten as

$$p_{\text{same}} \simeq \exp(-\gamma_{\text{m}} T), \tag{6.514}$$

where the decay rate γ_{m} is given by

$$\gamma_{\text{m}} = \frac{\omega^2 \tau_{\text{m}}}{4}, \tag{6.515}$$

and where $\tau_{\text{m}} = T/N$ is the time difference between successive measurements.

29. The eigenvectors of $\mathbf{S} \cdot \hat{\mathbf{u}}$ with eigenvalues $\pm \hbar/2$ are given by

$$|+; \hat{\mathbf{u}}\rangle = \cos\frac{\theta}{2} e^{-i\frac{\varphi}{2}} |+\rangle + \sin\frac{\theta}{2} e^{i\frac{\varphi}{2}} |-\rangle, \tag{6.516a}$$

$$|-; \hat{\mathbf{u}}\rangle = -\sin\frac{\theta}{2} e^{-i\frac{\varphi}{2}} |+\rangle + \cos\frac{\theta}{2} e^{i\frac{\varphi}{2}} |-\rangle, \tag{6.516b}$$

where the states $|\pm\rangle$ are eigenvectors of $\mathbf{S} \cdot \hat{\mathbf{z}}$. Let $P(\sigma_3, \sigma_2 | \sigma_1)$ be the probability to measure $\mathbf{S} \cdot \hat{\mathbf{u}} = \sigma_2 (\hbar/2)$ in the second measurement and to measure $\mathbf{S} \cdot \hat{\mathbf{z}} = \sigma_3 (\hbar/2)$ in the third measurement given that the result of the first measurement was $\mathbf{S} \cdot \hat{\mathbf{z}} = \sigma_1 (\hbar/2)$, and where $\sigma_n \in \{+, -\}$. The following holds

$$P(+, ++)= |\langle ++; \hat{\mathbf{u}} | \langle ++; \hat{\mathbf{u}} \rangle|^2 = \cos^4 \frac{\theta}{2}, \tag{6.517a}$$

$$P(+, -+)= |\langle -+; \hat{\mathbf{u}} | \langle -+; \hat{\mathbf{u}} \rangle|^2 = \sin^4 \frac{\theta}{2}, \tag{6.517b}$$

$$P(-, --)= |\langle --; \hat{\mathbf{u}} | \langle --; \hat{\mathbf{u}} \rangle|^2 = \cos^4 \frac{\theta}{2}, \tag{6.517c}$$

$$P(-, +-)= |\langle +-; \hat{\mathbf{u}} | \langle +-; \hat{\mathbf{u}} \rangle|^2 = \sin^4 \frac{\theta}{2}, \tag{6.517d}$$

thus independently on what was the result of the first measurement one has

$$p_{\text{same}} = \cos^4 \frac{\theta}{2} + \sin^4 \frac{\theta}{2} = 1 - \frac{1}{2} \sin^2 \theta . \quad (6.518)$$

30. The Hamiltonian is given by

$$\mathcal{H} = -\boldsymbol{\mu} \cdot \mathbf{B} . \quad (6.519)$$

Using Eq. (4.38) for μ_z one has

$$\begin{aligned} \frac{d\langle \mu_z \rangle}{dt} &= \frac{1}{i\hbar} \langle [\mu_z, \mathcal{H}] \rangle \\ &= -\frac{\gamma^2}{i\hbar} \langle B_x [S_z, S_x] + B_y [S_z, S_y] \rangle \\ &= \gamma^2 \langle B_y S_x - B_x S_y \rangle \\ &= \gamma (\boldsymbol{\mu} \times \mathbf{B}) \cdot \hat{\mathbf{z}} . \end{aligned} \quad (6.520)$$

Similar expressions are obtained for μ_x and μ_y that together can be written in a vector form as

$$\frac{d}{dt} \langle \boldsymbol{\mu} \rangle (t) = \gamma \langle \boldsymbol{\mu} \rangle (t) \times \mathbf{B} (t) . \quad (6.521)$$

31. The following holds (recall that $S_{\pm} = S_x \pm iS_y$)

$$\frac{S_- e^{i\varphi} - S_+ e^{-i\varphi}}{2} = i (S_x \sin \varphi - S_y \cos \varphi) . \quad (6.522)$$

- a) With the help of Eq. (6.522) and the relations $\hat{\mathbf{n}} \times \hat{\mathbf{z}} = \sin \theta (\sin \varphi, -\cos \varphi, 0)$ and $|\hat{\mathbf{n}} \times \hat{\mathbf{z}}| = \sin \theta$, where $\hat{\mathbf{z}} = (0, 0, 1)$, one finds that Eq. (6.202) holds.
- b) With the help of Eq. (6.164) one finds that [see Eqs. (6.200) and (6.201)]

$$|\hat{\mathbf{n}}\rangle = \exp\left(\theta \frac{S_- e^{i\varphi} - S_+ e^{-i\varphi}}{2\hbar}\right) |S, S\rangle = e^{-\log(1+\tan^2 \frac{\theta}{2})S} e^{e^{i\varphi} \tan \frac{\theta}{2} \hbar^{-1} S_-} |S, S\rangle , \quad (6.523)$$

hence Eq. (6.204) holds.

- c) See Eq. (6.165).
- d) The following holds [see Eqs. (6.205) and (6.136)]

$$\begin{aligned}
P_x &= \frac{1}{\hbar S} \langle \hat{\mathbf{n}} | S_x | \hat{\mathbf{n}} \rangle \\
&= \frac{1}{\hbar S} \langle S, S | e^{-\frac{i\varphi S_z}{\hbar}} e^{\frac{i\theta S_y}{\hbar}} \underbrace{e^{\frac{i\varphi S_z}{\hbar}} S_x e^{-\frac{i\varphi S_z}{\hbar}}}_{S_x \cos \varphi - S_y \sin \varphi} e^{-\frac{i\theta S_y}{\hbar}} e^{\frac{i\varphi S_z}{\hbar}} | S, S \rangle \\
&= \frac{\cos \varphi}{\hbar S} \langle S, S | \underbrace{e^{\frac{i\theta S_y}{\hbar}} S_x e^{-\frac{i\theta S_y}{\hbar}}}_{S_x \cos \theta + S_z \sin \theta} | S, S \rangle - \frac{\sin \varphi}{\hbar S} \langle S, S | S_y | S, S \rangle \\
&= \frac{\sin \theta \cos \varphi}{\hbar S} \langle S, S | S_z | S, S \rangle \\
&= \sin \theta \cos \varphi \\
&= \hat{\mathbf{n}} \cdot \hat{\mathbf{x}} .
\end{aligned} \tag{6.524}$$

In a similar way one finds that $P_y = \hat{\mathbf{n}} \cdot \hat{\mathbf{y}}$ and $P_z = \hat{\mathbf{n}} \cdot \hat{\mathbf{z}}$, hence Eq. (6.206) holds.

e) The time evolution operator $u(t)$ is given by [see Eq. (4.9)]

$$u(t) = \exp\left(-\frac{i\omega_0 t S_z}{\hbar}\right), \tag{6.525}$$

thus [see Eq. (6.205)]

$$\begin{aligned}
u(t) | \hat{\mathbf{n}} \rangle &= u(t) \exp\left(-\frac{i\varphi S_z}{\hbar}\right) \exp\left(-\frac{i\theta S_y}{\hbar}\right) \exp\left(\frac{i\varphi S_z}{\hbar}\right) u^\dagger(t) u(t) | S, S \rangle \\
&= e^{-iS\omega_0 t} \exp\left(-\frac{i(\varphi + \omega_0 t) S_z}{\hbar}\right) \exp\left(-\frac{i\theta S_y}{\hbar}\right) \exp\left(\frac{i(\varphi + \omega_0 t) S_z}{\hbar}\right) | S, S \rangle \\
&= e^{-iS\omega_0 t} | \hat{\mathbf{n}}' \rangle ,
\end{aligned} \tag{6.526}$$

where

$$\hat{\mathbf{n}}' = (\sin \theta \cos(\varphi + \omega_0 t), \sin \theta \sin(\varphi + \omega_0 t), \cos \theta) . \tag{6.527}$$

f) With the help of Eq. (6.66), which for the current case be expressed as

$$\begin{aligned}
\hbar^{-1} S_- | S, S - n \rangle &= \sqrt{S(S+1) - (S-n)(S-n-1)} | S, S - n - 1 \rangle \\
&= \sqrt{(1+n)(2S-n)} | S, S - n - 1 \rangle ,
\end{aligned} \tag{6.528}$$

one finds that [see Eq. (6.204)]

$$\begin{aligned}
 |\hat{\mathbf{n}}\rangle &= \cos^{2S} \frac{\theta}{2} e^{e^{i\varphi} \tan \frac{\theta}{2} \hbar^{-1} S_-} |S, S\rangle \\
 &= \cos^{2S} \frac{\theta}{2} \sum_{n=0}^{\infty} \frac{\left(e^{i\varphi} \tan \frac{\theta}{2} \frac{S_-}{\hbar} \right)^n}{n!} |S, S\rangle \\
 &= \cos^{2S} \frac{\theta}{2} \sum_{n=0}^{2S} \left(e^{i\varphi} \tan \frac{\theta}{2} \right)^n \sqrt{\frac{(2S)!}{n! (2S-n)!}} |S, S-n\rangle,
 \end{aligned} \tag{6.529}$$

thus (recall the binomial theorem)

$$\begin{aligned}
 \langle \hat{\mathbf{n}}'' | \hat{\mathbf{n}}' \rangle &= \left(\cos \frac{\theta'}{2} \cos \frac{\theta''}{2} \right)^{2S} \sum_{n=0}^{2S} \left(e^{i(\varphi' - \varphi'')} \tan \frac{\theta'}{2} \tan \frac{\theta''}{2} \right)^n \frac{(2S)!}{n! (2S-n)!} \\
 &= \zeta^{2S}.
 \end{aligned} \tag{6.530}$$

where

$$\zeta = \cos \frac{\theta'}{2} \cos \frac{\theta''}{2} + e^{i(\varphi' - \varphi'')} \sin \frac{\theta'}{2} \sin \frac{\theta''}{2}. \tag{6.531}$$

For two given unit vectors $\hat{\mathbf{n}}' = (\sin \theta' \cos \varphi', \sin \theta' \sin \varphi', \cos \theta')$ and $\hat{\mathbf{n}}'' = (\sin \theta'' \cos \varphi'', \sin \theta'' \sin \varphi'', \cos \theta'')$ the following holds

$$\begin{aligned}
 \hat{\mathbf{n}}'' \cdot \hat{\mathbf{n}}' &= (\cos \varphi' \cos \varphi'' + \sin \varphi' \sin \varphi'') \sin \theta' \sin \theta'' + \cos \theta' \cos \theta'' \\
 &= \cos(\varphi' - \varphi'') \sin \theta' \sin \theta'' + \cos \theta' \cos \theta''.
 \end{aligned} \tag{6.532}$$

Moreover, the following holds

$$|\zeta|^2 = \frac{1 + \cos(\varphi' - \varphi'') \sin \theta' \sin \theta'' + \cos \theta' \cos \theta''}{2}, \tag{6.533}$$

thus Eq. (6.209) holds.

g) With the help of Eq. (6.529) one finds that

$$\begin{aligned}
 &\frac{2S+1}{4\pi} \int_{-1}^1 d(\cos \theta) \int_0^{2\pi} d\varphi |\hat{\mathbf{n}}\rangle \langle \hat{\mathbf{n}}| \\
 &= \frac{2S+1}{4\pi} \sum_{n', n''=0}^{2S} \sqrt{\frac{(2S)!}{n'! (2S-n')!} \frac{(2S)!}{n''! (2S-n'')!}} |S, S-n'\rangle \langle S, S-n''| \\
 &\quad \times \int_{-1}^1 d(\cos \theta) \cos^{4S} \frac{\theta}{2} \left(\tan \frac{\theta}{2} \right)^{n'} \left(\tan \frac{\theta}{2} \right)^{n''} \underbrace{\int_0^{2\pi} d\varphi e^{i\varphi(n'-n'')}}_{2\pi \delta_{n', n''}} \\
 &= \sum_{n=0}^{2S} \eta_n |S, S-n\rangle \langle S, S-n|,
 \end{aligned} \tag{6.534}$$

where

$$\begin{aligned}
\eta_n &= \frac{2S+1}{2} \frac{(2S)!}{n!(2S-n)!} \int_{-1}^1 d(\cos \theta) \cos^{4S} \frac{\theta}{2} \left(\tan \frac{\theta}{2} \right)^{2n} \\
&= \frac{2S+1}{2} \frac{(2S)!}{n!(2S-n)!} \int_{-1}^1 dq \left(\frac{1+q}{2} \right)^{2S} \left(\frac{1-q}{1+q} \right)^n \\
&= \frac{2S+1}{2^{2S+1}} \frac{(2S)!}{n!(2S-n)!} \int_0^2 du u^{2S-n} (2-u)^n .
\end{aligned} \tag{6.535}$$

Integration by parts yields

$$\begin{aligned}
\eta_n &= \frac{2S+1}{2^{2S+1}} \frac{(2S)!}{n!(2S-n)!} \int_0^2 du \left(\frac{d}{du} \frac{u^{2S-n+1}}{2S-n+1} \right) (2-u)^n \\
&= \frac{2S+1}{2^{2S+1}} \frac{(2S)!}{(n-1)!(2S-n+1)!} \int_0^2 du u^{2S-n+1} (2-u)^{n-1} \\
&= \eta_{n-1} ,
\end{aligned} \tag{6.536}$$

and the following holds

$$\eta_0 = \frac{2S+1}{2^{2S+1}} \int_0^2 du u^{2S} = 1 , \tag{6.537}$$

thus $\eta_n = 1$, hence Eq. (6.210) holds [recall Eq. (2.23)].

- h) For two given unit vectors $\hat{\mathbf{n}}' = (\sin \theta' \cos \varphi', \sin \theta' \sin \varphi', \cos \theta')$ and $\hat{\mathbf{n}}'' = (\sin \theta'' \cos \varphi'', \sin \theta'' \sin \varphi'', \cos \theta'')$ one has for a general operator O [see Eq. (6.529)]

$$\begin{aligned}
\langle \hat{\mathbf{n}}'' | O | \hat{\mathbf{n}}' \rangle &= \cos^{2S} \frac{\theta'}{2} \cos^{2S} \frac{\theta''}{2} \sum_{n', n''=0}^{2S} \left(e^{i\varphi'} \tan \frac{\theta'}{2} \right)^{n'} \left(e^{-i\varphi''} \tan \frac{\theta''}{2} \right)^{n''} \\
&\quad \times \sqrt{\frac{(2S)!}{n'!(2S-n')!} \frac{(2S)!}{n''!(2S-n'')!}} \langle S, S-n'' | O | S, S-n' \rangle ,
\end{aligned} \tag{6.538}$$

thus

$$\hbar^{-1} \langle \hat{\mathbf{n}}'' | S_z | \hat{\mathbf{n}}' \rangle = \left(\cos \frac{\theta'}{2} \cos \frac{\theta''}{2} \right)^{2S} \sum_{n=0}^{2S} \frac{(2S)!}{n!(2S-n)!} (S-n) \left(e^{i(\varphi'-\varphi'')} \tan \frac{\theta'}{2} \tan \frac{\theta''}{2} \right)^n . \tag{6.539}$$

Taking the derivative with respect to x of the identity (the binomial theorem)

$$(1+x)^{2S} = \sum_{n=0}^{2S} \frac{(2S)!}{n!(2S-n)!} x^n , \tag{6.540}$$

and multiplying by x leads to

$$2Sx(1+x)^{2S-1} = \sum_{n=0}^{2S} \frac{(2S)!}{n!(2S-n)!} nx^n, \quad (6.541)$$

thus

$$\hbar^{-1} \langle \hat{\mathbf{n}}'' | S_z | \hat{\mathbf{n}}' \rangle = S \left(\cos \frac{\theta'}{2} \cos \frac{\theta''}{2} + e^{i(\varphi' - \varphi'')} \sin \frac{\theta'}{2} \sin \frac{\theta''}{2} \right)^{2S} \frac{1 - e^{i(\varphi' - \varphi'')} \tan \frac{\theta'}{2} \tan \frac{\theta''}{2}}{1 + e^{i(\varphi' - \varphi'')} \tan \frac{\theta'}{2} \tan \frac{\theta''}{2}}, \quad (6.542)$$

hence Eq. (6.211) holds.

32. Using Eq. (4.38) for S_z one has

$$\begin{aligned} \frac{d \langle S_z \rangle}{dt} &= -i \left\langle \left[S_z, \frac{\mathcal{H}}{\hbar} \right] \right\rangle \\ &= -\frac{\gamma}{i\hbar} \langle [S_z, B_x S_x + B_y S_y] \rangle + \frac{\omega_A}{i\hbar^2} \langle [S_z, N_x S_x^2 + N_y S_y^2] \rangle \\ &= \gamma (\langle \mathbf{S} \rangle \times \mathbf{B}) \cdot \hat{\mathbf{z}} + \frac{\omega_A (N_x - N_y)}{\hbar} \langle S_x S_y + S_y S_x \rangle. \end{aligned} \quad (6.543)$$

a) With the help of the identity

$$(\mathbf{S}_N \times \mathbf{S} - \mathbf{S} \times \mathbf{S}_N) \cdot \hat{\mathbf{z}} = (N_x - N_y) (S_x S_y + S_y S_x), \quad (6.544)$$

where $\mathbf{S} = (S_x, S_y, S_z)$ and $\mathbf{S}_N = (N_x S_x, N_y S_y, N_z S_z)$, one obtains

$$\frac{d \langle S_z \rangle}{dt} = \left(\gamma (\langle \mathbf{S} \rangle \times \mathbf{B}) + \frac{\omega_A \langle \mathbf{S}_N \times \mathbf{S} - \mathbf{S} \times \mathbf{S}_N \rangle}{\hbar} \right) \cdot \hat{\mathbf{z}}, \quad (6.545)$$

hence

$$\frac{d \langle \mathbf{S} \rangle}{dt} = \gamma \langle \mathbf{S} \rangle \times \mathbf{B} + \frac{\omega_A \langle \mathbf{S}_N \times \mathbf{S} - \mathbf{S} \times \mathbf{S}_N \rangle}{\hbar}. \quad (6.546)$$

b) For this case Eq. (6.546) becomes

$$\frac{d}{dt} \begin{pmatrix} \langle S_x \rangle \\ \langle S_y \rangle \end{pmatrix} = \begin{pmatrix} 0 & u_a \omega_0 + \omega_1 \cos(\omega t) \\ -u_b \omega_0 - \omega_1 \cos(\omega t) & 0 \end{pmatrix} \begin{pmatrix} \langle S_x \rangle \\ \langle S_y \rangle \end{pmatrix}, \quad (6.547)$$

where

$$u_a = 1 + \frac{2\omega_A s (N_z - N_y)}{\omega_0}, \quad (6.548)$$

$$u_b = 1 + \frac{2\omega_A s (N_z - N_x)}{\omega_0}. \quad (6.549)$$

Using the transformation

$$\alpha = \sqrt{u_b} \langle S_x \rangle + i\sqrt{u_a} \langle S_y \rangle , \quad (6.550)$$

one obtains [note that $\langle S_x \rangle = (\alpha + \alpha^*) / (2\sqrt{u_b})$ and $\langle S_y \rangle = (\alpha - \alpha^*) / (2i\sqrt{u_a})$]

$$\begin{aligned} \frac{d\alpha}{dt} &= \sqrt{u_b} \frac{d\langle S_x \rangle}{dt} + i\sqrt{u_a} \frac{d\langle S_y \rangle}{dt} \\ &= -i(\omega_e + \omega_g \cos(\omega t)) \alpha + i\omega_f \cos(\omega t) \alpha^* , \end{aligned} \quad (6.551)$$

where

$$\omega_e = \sqrt{u_a u_b} \omega_0 , \quad (6.552)$$

$$\omega_g = \frac{\left(\sqrt{\frac{u_b}{u_a}} + \sqrt{\frac{u_a}{u_b}} \right) \omega_1}{2} , \quad (6.553)$$

$$\omega_f = \frac{\left(\sqrt{\frac{u_b}{u_a}} - \sqrt{\frac{u_a}{u_b}} \right) \omega_1}{2} . \quad (6.554)$$

The transformation

$$\alpha = \beta e^{-i\omega_e t} , \quad (6.555)$$

yields

$$\frac{d\beta}{dt} = i \cos(\omega t) (-\omega_g \beta + \omega_f e^{2i\omega_e t} \beta^*) . \quad (6.556)$$

Note that when $\omega \simeq 2\omega_0$ the dominant pumping term is the so-called parametric term proportional to $\omega_f \beta^*$.

33. The matrix representation of the Hamiltonian in the basis $\{|1\rangle, |2\rangle, |3\rangle\}$ is given by

$$\hbar^{-1} \mathcal{H} \doteq \begin{pmatrix} \omega_1 & 0 & \Omega_p e^{i(\phi_p + (\omega_3 - \omega_1 + \Delta_p)t)} \\ 0 & \omega_2 & \Omega_s e^{i(\phi_s + (\omega_3 - \omega_2 + \Delta_s)t)} \\ \Omega_p e^{-i(\phi_p + (\omega_3 - \omega_1 + \Delta_p)t)} & \Omega_s e^{-i(\phi_s + (\omega_3 - \omega_2 + \Delta_s)t)} & \omega_3 \end{pmatrix} . \quad (6.557)$$

By applying the transformation (6.375) with a unitary matrix U given by

$$U = \begin{pmatrix} e^{-i((\omega_1 - \Delta_p)t - \phi_p)} & 0 & 0 \\ 0 & e^{-i((\omega_2 - \Delta_s)t - \phi_s)} & 0 \\ 0 & 0 & e^{-i\omega_3 t} \end{pmatrix} , \quad (6.558)$$

the Hamiltonian \mathcal{H} is transformed into the Hamiltonian \mathcal{H}' , which is given by

$$\hbar^{-1}\mathcal{H}' \doteq \begin{pmatrix} \Delta_p & 0 & \Omega_p \\ 0 & \Delta_s & \Omega_s \\ \Omega_p & \Omega_s & 0 \end{pmatrix}. \quad (6.559)$$

For vanishing detunings, i.e. when $\Delta_p = \Delta_s = 0$, the Hamiltonian \mathcal{H}' can be expressed as

$$\hbar^{-1}\mathcal{H}' \doteq \sqrt{\Omega_p^2 + \Omega_s^2} \begin{pmatrix} 0 & 0 & \cos \theta \\ 0 & 0 & \sin \theta \\ \cos \theta & \sin \theta & 0 \end{pmatrix}, \quad (6.560)$$

where

$$\tan \theta = \frac{\Omega_s}{\Omega_p}. \quad (6.561)$$

The following holds

$$\begin{pmatrix} 0 & 0 & \cos \theta \\ 0 & 0 & \sin \theta \\ \cos \theta & \sin \theta & 0 \end{pmatrix} \begin{pmatrix} -\sin \theta \\ \cos \theta \\ 0 \end{pmatrix} = \begin{pmatrix} 0 \\ 0 \\ 0 \end{pmatrix}, \quad (6.562)$$

i.e. the state vector $(-\sin \theta, \cos \theta, 0)^T$ is an eigenvector of \mathcal{H}' (with a vanishing eigenvalue). It is called a dark state since in that state the probability to find the system in the state $|3\rangle$ vanishes.

34. Using Eq. (6.138), which is given by

$$(\boldsymbol{\sigma} \cdot \mathbf{a})(\boldsymbol{\sigma} \cdot \mathbf{b}) = \mathbf{a} \cdot \mathbf{b} + i\boldsymbol{\sigma} \cdot (\mathbf{a} \times \mathbf{b}), \quad (6.563)$$

one has

$$\begin{aligned} \left[\boldsymbol{\sigma} \cdot \left(\mathbf{p} - \frac{q}{c} \mathbf{A} \right) \right]^2 &= \left(\mathbf{p} - \frac{q}{c} \mathbf{A} \right)^2 + i\boldsymbol{\sigma} \cdot ((\mathbf{p} - q\mathbf{A}) \times (\mathbf{p} - q\mathbf{A})) \\ &= \left(\mathbf{p} - \frac{q}{c} \mathbf{A} \right)^2 - i\frac{q}{c} \boldsymbol{\sigma} \cdot (\mathbf{A} \times \mathbf{p} + \mathbf{p} \times \mathbf{A}). \end{aligned} \quad (6.564)$$

The z component of the term $(\mathbf{A} \times \mathbf{p} + \mathbf{p} \times \mathbf{A})$ can be expressed as

$$\begin{aligned} (\mathbf{A} \times \mathbf{p} + \mathbf{p} \times \mathbf{A}) \cdot \hat{\mathbf{z}} &= A_x p_y - A_y p_x + p_x A_y - p_y A_x \\ &= [A_x, p_y] - [A_y, p_x], \end{aligned} \quad (6.565)$$

thus, with the help of Eq. (3.76) one finds that

$$(\mathbf{A} \times \mathbf{p} + \mathbf{p} \times \mathbf{A}) \cdot \hat{\mathbf{z}} = i\hbar \left(\frac{dA_x}{dy} - \frac{dA_y}{dx} \right) = -i\hbar (\nabla \times \mathbf{A}) \cdot \hat{\mathbf{z}}. \quad (6.566)$$

Similar results can be obtained for the x and y components, thus

$$\left[\boldsymbol{\sigma} \cdot \left(\mathbf{p} - \frac{q}{c} \mathbf{A} \right) \right]^2 = \left(\mathbf{p} - \frac{q}{c} \mathbf{A} \right)^2 - \frac{q\hbar}{c} \boldsymbol{\sigma} \cdot \mathbf{B}. \quad (6.567)$$

35. Since

$$\langle j, m | J_x | j, m \rangle = \langle j, m | J_y | j, m \rangle = 0 , \quad (6.568)$$

and

$$J_x^2 + J_y^2 = \mathbf{J}^2 - J_z^2 , \quad (6.569)$$

one finds that

$$\begin{aligned} \langle j, m | \left[(\Delta J_x)^2 + (\Delta J_y)^2 \right] | j, m \rangle &= \langle j, m | \mathbf{J}^2 | j, m \rangle - \langle j, m | J_z^2 | j, m \rangle \\ &= \hbar^2 (j^2 + j - m^2) . \end{aligned} \quad (6.570)$$

36. The condition is

$$\mathbf{p} \cdot \mathbf{A} = \mathbf{A} \cdot \mathbf{p} , \quad (6.571)$$

or

$$[p_x, A_x] + [p_y, A_y] + [p_z, A_z] = 0 , \quad (6.572)$$

or using Eq. (3.76)

$$\frac{\partial A_x}{\partial x} + \frac{\partial A_y}{\partial y} + \frac{\partial A_z}{\partial z} = 0 , \quad (6.573)$$

or

$$\nabla \cdot \mathbf{A} = 0 . \quad (6.574)$$

37. The Hamiltonian is given by Eq. (1.62)

$$\mathcal{H} = \frac{(\mathbf{p} - \frac{q}{c} \mathbf{A})^2}{2m} + q\varphi , \quad (6.575)$$

thus, the coordinates representation of $\mathcal{H} |\alpha\rangle = E |\alpha\rangle$ is given by

$$\langle \mathbf{r}' | \mathcal{H} |\alpha\rangle = E \langle \mathbf{r}' | \alpha \rangle . \quad (6.576)$$

Using the notation

$$\langle \mathbf{r}' | \alpha \rangle = \psi(\mathbf{r}') \quad (6.577)$$

for the wavefunction together with Eqs. (3.23) and (3.29) one has

$$\left[\frac{1}{2m} \left(-i\hbar \nabla - \frac{q}{c} \mathbf{A} \right)^2 + q\varphi \right] \psi(\mathbf{r}') = E \psi(\mathbf{r}') . \quad (6.578)$$

38. The Hamiltonian is given by

$$\begin{aligned}\mathcal{H} &= \frac{(\mathbf{p} - \frac{e}{c}\mathbf{A})^2}{2m} = \frac{p_x^2 + p_z^2}{2m} + \frac{(p_y - \frac{eBx}{c})^2}{2m} \\ &= \frac{p_x^2}{2m} + \frac{1}{2}m\omega_c^2 \left(x - \frac{cp_y}{eB}\right)^2 + \frac{p_z^2}{2m},\end{aligned}\tag{6.579}$$

where

$$\omega_c = \frac{eB}{mc}.\tag{6.580}$$

Using the clue

$$\psi(x, y, z) = \chi(x) \exp(ik_y y) \exp(ik_z z)\tag{6.581}$$

one finds that the time independent Schrödinger equation for the wave function $\chi(x)$ is thus given by

$$\left[\frac{p_x^2}{2m} + \frac{1}{2}m\omega_c^2 \left(x - \frac{c\hbar k_y}{eB}\right)^2 \right] \chi(x) = \left(E - \frac{\hbar^2 k_z^2}{2m}\right) \chi(x),\tag{6.582}$$

where $\hat{p}_x = -i\hbar\partial/\partial x$, thus the eigenenergies are given by

$$E_{n,k} = \hbar\omega_c \left(n + \frac{1}{2}\right) + \frac{\hbar^2 k_z^2}{2m},\tag{6.583}$$

where n is integer and k is real, and the ground state energy is

$$E_{n=0,k=0} = \frac{\hbar\omega_c}{2}.\tag{6.584}$$

39. Using the gauge $\mathbf{A} = Bx\hat{y}$ the Hamiltonian is given by [see Eq. (1.62)]

$$\begin{aligned}\mathcal{H} &= \frac{(\mathbf{p} - \frac{q}{c}\mathbf{A})^2}{2m} - qEx \\ &= \frac{p_x^2 + p_z^2}{2m} + \frac{(p_y - \frac{qBx}{c})^2}{2m} - qEx.\end{aligned}\tag{6.585}$$

The last two terms can be written as

$$\frac{(p_y - \frac{qBx}{c})^2}{2m} - qEx = \frac{p_y^2}{2m} + \frac{1}{2}m\omega_c^2 \left[(x - x_0)^2 - x_0^2\right],\tag{6.586}$$

where

$$\omega_c = \frac{qB}{mc}, \quad (6.587)$$

and

$$x_0 = \frac{mc^2}{q^2 B^2} \left(qE + \frac{qp_y}{mc} B \right). \quad (6.588)$$

Substituting the trial wavefunction

$$\psi(x, y, z) = \varphi(x) \exp(ik_y y) \exp(ik_z z), \quad (6.589)$$

into the three dimensional Schrödinger equation yields a one-dimensional Schrödinger equation

$$\left[\frac{\hat{p}_x^2}{2m} + \frac{1}{2} m \omega_c^2 (x - \tilde{x}_0)^2 - \frac{1}{2} m \omega_c^2 \tilde{x}_0^2 + \frac{\hbar^2 k_y^2 + \hbar^2 k_z^2}{2m} \right] \varphi(x) = E \varphi(x), \quad (6.590)$$

where $\hat{p}_x = -i\hbar\partial/\partial x$ and where

$$\tilde{x}_0 = \frac{mc^2}{q^2 B^2} \left(qE + \frac{q\hbar k_y}{mc} B \right). \quad (6.591)$$

This equation describes a harmonic oscillator with a minimum potential at $x = \tilde{x}_0$, with added constant terms that give rise to a shift in the energy level, which are thus given by

$$\begin{aligned} E_{n, k_y, k_z} &= \hbar\omega_c \left(n + \frac{1}{2} \right) - \frac{1}{2} m \omega_c^2 \tilde{x}_0^2 + \frac{\hbar^2 k_y^2 + \hbar^2 k_z^2}{2m} \\ &= \hbar\omega_c \left(n + \frac{1}{2} \right) - \frac{mc^2 E^2}{2B^2} - \frac{c\hbar k_y E}{B} + \frac{\hbar^2 k_z^2}{2m}, \end{aligned} \quad (6.592)$$

where $n = 0, 1, 2, \dots$ and where the momentum variables k_y and k_z can take any real value.

40. The Schrödinger equation reads

$$\left[\frac{(\hat{\mathbf{p}} - \frac{e}{c} \mathbf{A})^2}{2m} + U(y) \right] \psi(x, y) = E \psi(x, y), \quad (6.593)$$

where

$$\hat{\mathbf{p}} = -i\hbar \nabla.$$

Employing the gauge $\mathbf{A} = -By\hat{\mathbf{x}}$ one has

$$\left[\frac{(\hat{p}_x + \frac{e}{c}By)^2}{2m} + \frac{\hat{p}_y^2}{2m} + U(y) \right] \psi(x, y) = E\psi(x, y) , \quad (6.594)$$

where $\hat{p}_x = -i\hbar\partial/\partial x$ and $\hat{p}_y = -i\hbar\partial/\partial y$. By substituting the trial wavefunction

$$\psi(x, y) = \exp(ikx) \chi(y) , \quad (6.595)$$

one obtains a one-dimensional Schrödinger equation for $\chi(y)$

$$\left[\frac{\hat{p}_y^2}{2m} + \frac{(\frac{e}{c}By + \hbar k)^2}{2m} + \frac{1}{2}m\omega_0^2 y^2 \right] \chi(y) = E\chi(y) , \quad (6.596)$$

or

$$\left[\frac{\hat{p}_y^2}{2m} + \frac{\hbar^2 k^2}{2m} + \frac{1}{2}m\omega_{c0}^2 y^2 - \frac{eB\hbar k}{mc} y \right] \chi(y) = E\chi(y) , \quad (6.597)$$

where $\omega_{c0}^2 \equiv \omega_c^2 + \omega_0^2$ and $\omega_c = |e|B/mc$. This can also be written as

$$\left[\frac{\hat{p}_y^2}{2m} + \frac{1}{2}m\omega_{c0}^2 \left(y - \frac{eB\hbar k}{m^2 c \omega_{c0}^2} \right)^2 + \frac{\hbar^2 k^2}{2m} \frac{\omega_0^2}{\omega_{c0}^2} \right] \chi(y) = E\chi(y) . \quad (6.598)$$

This is basically a one-dimensional Schrödinger equation with a parabolic potential of a harmonic oscillator and the eigenenergies are thus given by:

$$E(n, k) = \hbar\omega_{c0} \left(n + \frac{1}{2} \right) + \frac{\hbar^2 k^2}{2m} \frac{\omega_0^2}{\omega_{c0}^2} ,$$

where $n = 0, 1, 2, \dots$ and k is real.

41. It is convenient to choose a gauge having cylindrical symmetry, namely

$$\mathbf{A} = -\frac{1}{2}\mathbf{r} \times \mathbf{B} . \quad (6.599)$$

For this gauge $\nabla \cdot \mathbf{A} = 0$, thus according to Eq. (6.219) the Hamiltonian is given by

$$\mathcal{H} = \frac{1}{2\mu}\mathbf{p}^2 - \frac{q}{\mu c}\mathbf{p} \cdot \mathbf{A} + \frac{q^2}{2\mu c^2}\mathbf{A}^2 . \quad (6.600)$$

The Schrödinger equation in cylindrical coordinates (ρ, z, ϕ) is given by (note that $\mathbf{A} = (\rho B/2)\hat{\phi}$)

$$-\frac{\hbar^2}{2\mu} \left(\frac{1}{\rho} \frac{\partial}{\partial \rho} \left(\rho \frac{\partial \psi}{\partial \rho} \right) + \frac{1}{\rho^2} \frac{\partial^2 \psi}{\partial \phi^2} + \frac{\partial^2 \psi}{\partial z^2} \right) + \frac{i\hbar q B}{2\mu c} \frac{\partial \psi}{\partial \phi} + \frac{q^2}{2\mu c^2} \left(\frac{\rho B}{2} \right)^2 \psi = E\psi .$$

(6.601)

The particle is constrained to move along the ring, which is located at $z = 0$ and $\rho = a$, thus the effective one-dimensional Schrödinger equation of the system is given by

$$-\frac{\hbar^2}{2\mu a^2} \frac{\partial^2 \psi}{\partial \phi^2} + \frac{i\hbar q B}{2\mu c} \frac{\partial \psi}{\partial \phi} + \frac{q^2 a^2 B^2}{8\mu c^2} \psi = E\psi . \quad (6.602)$$

a) Consider a solution of the form

$$\psi(\phi) = \frac{1}{\sqrt{2\pi a}} \exp(im\phi) , \quad (6.603)$$

where the pre factor $(2\pi a)^{-1/2}$ ensures normalization. The continuity requirement that $\psi(2\pi) = \psi(0)$ implies that m must be an integer. Substituting this solution into the Schrödinger equation (6.602) yields

$$\begin{aligned} E_m &= \frac{\hbar^2 m^2}{2\mu a^2} - \frac{\hbar q B m}{2\mu c} + \frac{q^2 a^2 B^2}{8\mu c^2} \\ &= \frac{\hbar^2}{2\mu a^2} \left(m^2 - \frac{q B a^2}{c\hbar} m + \frac{1}{4} \left(\frac{q B a^2}{c\hbar} \right)^2 \right) \\ &= \frac{\hbar^2}{2\mu a^2} \left(m - \frac{q B a^2}{2c\hbar} \right)^2 \\ &= \frac{\hbar^2}{2\mu a^2} \left(m - \frac{\Phi}{\Phi_0} \right)^2 , \end{aligned} \quad (6.604)$$

where

$$\Phi = B\pi a^2 , \quad (6.605)$$

is the magnetic flux threading the ring and

$$\Phi_0 = \frac{c\hbar}{q} . \quad (6.606)$$

b) In general the current density is given by Eq. (4.274). For a wavefunction having the form

$$\psi(\mathbf{r}) = \alpha(\mathbf{r}) e^{i\beta(\mathbf{r})} , \quad (6.607)$$

where both α and β are real, one has

$$\begin{aligned}
 \mathbf{J} &= \frac{\hbar}{\mu} \operatorname{Im} [\alpha (\nabla (\alpha) + \alpha \nabla (i\beta))] - \frac{q}{\mu c} (\rho \mathbf{A}) \\
 &= \frac{\hbar \alpha^2}{\mu} \nabla (\beta) - \frac{q}{\mu c} \alpha^2 \mathbf{A} \\
 &= \frac{|\psi|^2}{\mu} \left(\hbar \nabla (\beta) - \frac{q}{c} \mathbf{A} \right) .
 \end{aligned} \tag{6.608}$$

In the present case one has

$$\mathbf{A} = \frac{\rho B \hat{\phi}}{2} , \tag{6.609}$$

$$\nabla \beta = \frac{m}{a} \hat{\phi} , \tag{6.610}$$

and the normalized wavefunctions are

$$\psi_m (\phi) = \frac{1}{\sqrt{2\pi a}} \exp (im\phi) , \tag{6.611}$$

thus

$$\mathbf{J}_m = \frac{1}{2\pi a \mu} \left(\hbar \frac{m}{a} - \frac{q a B}{c} \frac{1}{2} \right) \hat{\phi} = \frac{\hbar}{2\pi a^2 \mu} \left(m - \frac{\Phi}{\Phi_0} \right) \hat{\phi} . \tag{6.612}$$

Note that the following holds

$$|\mathbf{J}_m| = -\frac{c}{q} \frac{\partial E_m}{\partial \Phi} . \tag{6.613}$$

42. The following holds

$$\psi (x, y, z) = Y_1^0 (\theta, \phi) R (r) , \tag{6.614}$$

where (recall that $r = \sqrt{x^2 + y^2 + z^2}$ and $z = r \cos \theta$)

$$R (r) = \sqrt{\frac{4\pi}{3}} A r \exp \left(-\frac{r^2}{r_0^2} \right) , \tag{6.615}$$

and where $Y_1^0 (\theta, \phi) = \sqrt{3/4\pi} \cos \theta$ [see Eq. (6.132)], thus $\langle L_z \rangle = 0$, $\langle (\Delta L_z)^2 \rangle = 0$, $\langle L^2 \rangle = 2\hbar^2$ and $\langle (\Delta L^2)^2 \rangle = 0$.

43. With the help of Eq. (6.84), the identity

$$\cos^2 \phi = \left(\frac{e^{i\phi} + e^{-i\phi}}{2} \right)^2 = \frac{e^{2i\phi} + 2 + e^{-2i\phi}}{4} , \tag{6.616}$$

and the integral for n integer

$$\int_0^{2\pi} d\phi e^{ni\phi} = 2\pi \delta_{n,0} , \tag{6.617}$$

one finds that

$$\langle \mathcal{H} \rangle = \frac{\int_0^{2\pi} d\phi \psi^* \frac{(-i\hbar \frac{\partial}{\partial \phi})^2}{2I} \psi}{\int_0^{2\pi} d\phi \psi^* \psi} = \frac{2\hbar^2}{3I}, \quad (6.618)$$

and

$$\langle \mathcal{H}^2 \rangle = \frac{\int_0^{2\pi} d\phi \psi^* \frac{(-i\hbar \frac{\partial}{\partial \phi})^4}{4I^2} \psi}{\int_0^{2\pi} d\phi \psi^* \psi} = \frac{4\hbar^4}{3I^2}, \quad (6.619)$$

and thus

$$\langle \mathcal{H}^2 \rangle - \langle \mathcal{H} \rangle^2 = \frac{8\hbar^4}{9I^2}. \quad (6.620)$$

44. The Hamiltonian can be written as

$$\begin{aligned} \mathcal{H} &= \frac{\mathbf{L}^2 - L_z^2}{2I_{xy}} + \frac{L_z^2}{2I_z} \\ &= \frac{\mathbf{L}^2}{2I_{xy}} + \left(\frac{1}{2I_z} - \frac{1}{2I_{xy}} \right) L_z^2, \end{aligned} \quad (6.621)$$

Thus the states $|l, m\rangle$ (the standard eigenstates of \mathbf{L}^2 and L_z) are eigenstates of \mathcal{H} and the following holds

$$\mathcal{H} |l, m\rangle = E_{l,m} |l, m\rangle, \quad (6.622)$$

where

$$E_{l,m} = \hbar^2 \left[\frac{l(l+1)}{2I_{xy}} + \left(\frac{1}{2I_z} - \frac{1}{2I_{xy}} \right) m^2 \right]. \quad (6.623)$$

Using the expression

$$Y_1^{\pm 1}(\theta, \phi) = \mp \sqrt{\frac{3}{8\pi}} \sin \theta e^{\pm i\phi}, \quad (6.624)$$

one finds that

$$\sin \theta \cos \phi = \sqrt{\frac{2\pi}{3}} (Y_1^{-1} - Y_1^1), \quad (6.625)$$

thus the normalized state at $t = 0$ can be written as

$$|\psi(0)\rangle = \frac{1}{\sqrt{2}} (|1, -1\rangle - |1, 1\rangle) . \quad (6.626)$$

Since $E_{1,-1} = E_{1,1}$ the state $|\psi(0)\rangle$ is stationary. Moreover

$$\begin{aligned} \langle\psi(t)|L_z|\psi(t)\rangle &= \langle\psi(0)|L_z|\psi(0)\rangle \\ &= \frac{1}{2} (\langle(1, -1| - \langle(1, 1|)) L_z (|1, -1\rangle - |1, 1\rangle)) \\ &= \frac{1}{2} (\langle(1, -1| - \langle(1, 1|)) ((-1) - 1)) \\ &= 0 . \end{aligned} \quad (6.627)$$

45. With the help of the relations

$$L_x = \frac{L_+ + L_-}{2} , \quad (6.628)$$

$$L_+ |l, m\rangle = \hbar\sqrt{l(l+1) - m(m+1)} |l, m+1\rangle , \quad (6.629)$$

$$L_- |l, m\rangle = \hbar\sqrt{l(l+1) - m(m-1)} |l, m-1\rangle . \quad (6.630)$$

one finds

a)

$$L_x \doteq \frac{\hbar}{\sqrt{2}} \begin{pmatrix} 0 & 1 & 0 \\ 1 & 0 & 1 \\ 0 & 1 & 0 \end{pmatrix} . \quad (6.631)$$

b)

$$\langle L_x \rangle = \frac{\hbar}{\sqrt{2}} \begin{pmatrix} \frac{1}{2} & \frac{1}{\sqrt{2}} & \frac{1}{2} \end{pmatrix} \begin{pmatrix} 0 & 1 & 0 \\ 1 & 0 & 1 \\ 0 & 1 & 0 \end{pmatrix} \begin{pmatrix} \frac{1}{2} \\ \frac{1}{\sqrt{2}} \\ \frac{1}{2} \end{pmatrix} = \hbar . \quad (6.632)$$

c)

$$\langle L_x \rangle = \frac{\hbar}{\sqrt{2}} \begin{pmatrix} -\frac{1}{\sqrt{2}} & 0 & \frac{1}{\sqrt{2}} \end{pmatrix} \begin{pmatrix} 0 & 1 & 0 \\ 1 & 0 & 1 \\ 0 & 1 & 0 \end{pmatrix} \begin{pmatrix} -\frac{1}{\sqrt{2}} \\ 0 \\ \frac{1}{\sqrt{2}} \end{pmatrix} = 0 . \quad (6.633)$$

d)

$$D_{\hat{\mathbf{z}}}(\phi) = \exp\left(-\frac{i\phi L_z}{\hbar}\right) \doteq \begin{pmatrix} \exp(-i\phi) & 0 & 0 \\ 0 & 1 & 0 \\ 0 & 0 & \exp(i\phi) \end{pmatrix} . \quad (6.634)$$

e) In general

$$D_{\hat{\mathbf{n}}}(\mathrm{d}\phi) = \exp\left(-\frac{i(\mathrm{d}\phi) \mathbf{L} \cdot \hat{\mathbf{n}}}{\hbar}\right) = 1 - \frac{i(\mathrm{d}\phi) \mathbf{L} \cdot \hat{\mathbf{n}}}{\hbar} + O((\mathrm{d}\phi)^2) ,$$

(6.635)

thus

$$D_{\hat{x}}(d\phi) \doteq \begin{pmatrix} 1 & -\frac{i(d\phi)}{\sqrt{2}} & 0 \\ -\frac{i(d\phi)}{\sqrt{2}} & 1 & -\frac{i(d\phi)}{\sqrt{2}} \\ 0 & -\frac{i(d\phi)}{\sqrt{2}} & 1 \end{pmatrix} + O((d\phi)^2) . \quad (6.636)$$

46. Using

$$L_z = xp_y - yp_x , \quad (6.637)$$

$$x = \sqrt{\frac{\hbar}{2m\omega}} (a_x + a_x^\dagger) , \quad (6.638)$$

$$y = \sqrt{\frac{\hbar}{2m\omega}} (a_y + a_y^\dagger) , \quad (6.639)$$

$$p_x = i\sqrt{\frac{m\hbar\omega}{2}} (-a_x + a_x^\dagger) , \quad (6.640)$$

$$p_y = i\sqrt{\frac{m\hbar\omega}{2}} (-a_y + a_y^\dagger) , \quad (6.641)$$

one finds

$$\begin{aligned} L_z &= \frac{i\hbar}{2} [(a_x + a_x^\dagger)(-a_y + a_y^\dagger) - (a_y + a_y^\dagger)(-a_x + a_x^\dagger)] \\ &= i\hbar (a_x a_y^\dagger - a_x^\dagger a_y) . \end{aligned} \quad (6.642)$$

a) Thus

$$\langle L_z \rangle = i\hbar (\alpha_x \alpha_y^* - \alpha_x^* \alpha_y) . \quad (6.643)$$

b) Using the commutation relations

$$[a_x, a_x^\dagger] = 1 , \quad (6.644)$$

$$[a_y, a_y^\dagger] = 1 , \quad (6.645)$$

one finds

$$\begin{aligned} \langle L_z^2 \rangle &= -\hbar^2 \langle \alpha_x, \alpha_y, \alpha_z | (a_x \alpha_y^* - \alpha_x^* a_y) (a_x a_y^\dagger - a_x^\dagger a_y) | \alpha_x, \alpha_y, \alpha_z \rangle \\ &= \hbar^2 \left[|\alpha_x|^2 (1 + |\alpha_y|^2) + |\alpha_y|^2 (1 + |\alpha_x|^2) - (\alpha_x \alpha_y^*)^2 - (\alpha_x^* a_y)^2 \right] , \end{aligned} \quad (6.646)$$

thus

$$\begin{aligned} (\Delta L_z)^2 &= \hbar^2 \left[|\alpha_x|^2 (1 + |\alpha_y|^2) + |\alpha_y|^2 (1 + |\alpha_x|^2) + (\alpha_x \alpha_y^* - \alpha_x^* a_y)^2 - (\alpha_x \alpha_y^*)^2 - (\alpha_x^* a_y)^2 \right] \\ &= \hbar^2 \left[|\alpha_x|^2 (1 + |\alpha_y|^2) + |\alpha_y|^2 (1 + |\alpha_x|^2) - 2 |\alpha_x|^2 |\alpha_y|^2 \right] \\ &= \hbar^2 (|\alpha_x|^2 + |\alpha_y|^2) , \end{aligned} \quad (6.647)$$

and

$$\Delta L_z = \hbar \sqrt{|\alpha_x|^2 + |\alpha_y|^2} . \quad (6.648)$$

47. The normalization constant can be chosen to be $A = 1/\sqrt{2}$. In general:

$$L_x = \frac{L_+ + L_-}{2} , \quad (6.649)$$

$$L_+ |l, m\rangle = \hbar \sqrt{l(l+1) - m(m+1)} |l, m+1\rangle , \quad (6.650)$$

$$L_- |l, m\rangle = \hbar \sqrt{l(l+1) - m(m-1)} |l, m-1\rangle . \quad (6.651)$$

a) The following holds

$$\begin{aligned} L_x |\alpha\rangle &= \frac{(L_- |1, 1\rangle - L_+ |1, -1\rangle)}{2\sqrt{2}} \\ &= \frac{\hbar(|1, 0\rangle - |1, 0\rangle)}{2} = 0 , \end{aligned} \quad (6.652)$$

thus

$$\langle L_x \rangle = 0 . \quad (6.653)$$

b) Using $L_x |\alpha\rangle = 0$ one finds

$$\langle (\Delta L_x)^2 \rangle = \langle L_x^2 \rangle - \langle L_x \rangle^2 = 0 - 0 = 0 . \quad (6.654)$$

48. The Hamiltonian can be expressed as

$$\mathcal{H} = \frac{\mathbf{L}^2}{2I_1} + \frac{L_z^2}{2I_2} - \frac{L_z^2}{2I_1} = \frac{\mathbf{L}^2}{2I_1} + \frac{L_z^2}{2I_e} , \quad (6.655)$$

where

$$I_e = \frac{I_1 I_2}{I_1 - I_2} . \quad (6.656)$$

Thus, the angular momentum states $|l, m\rangle$, which satisfy

$$\mathbf{L}^2 |l, m\rangle = l(l+1) \hbar^2 |l, m\rangle , \quad (6.657)$$

$$L_z |l, m\rangle = m \hbar |l, m\rangle , \quad (6.658)$$

are eigenvector of \mathcal{H}

$$\mathcal{H} |l, m\rangle = E_{l,m} |l, m\rangle , \quad (6.659)$$

where

$$E_{l,m} = \frac{l(l+1) \hbar^2}{2I_1} + \frac{m^2 \hbar^2}{2I_e} = \frac{\hbar^2}{2I_1} \left(l(l+1) - m^2 + m^2 \frac{I_1}{I_2} \right) . \quad (6.660)$$

a) Since $[\mathcal{H}, L_z] = 0$ one has

$$\exp\left(\frac{iL_z\phi}{\hbar}\right) \mathcal{H} \exp\left(-\frac{iL_z\phi}{\hbar}\right) = \mathcal{H}, \quad (6.661)$$

thus for the ground state $l = m = 0$

$$A_z(\phi) = \langle \psi_0 | \mathcal{H} | \psi_0 \rangle = E_{0,0} = 0. \quad (6.662)$$

b) The operator L_x can be expressed as

$$L_x = \frac{L_+ + L_-}{2}. \quad (6.663)$$

In general

$$L_+ |l, m\rangle = \hbar \sqrt{l(l+1) - m(m+1)} |l, m+1\rangle, \quad (6.664)$$

$$L_- |l, m\rangle = \hbar \sqrt{l(l+1) - m(m-1)} |l, m-1\rangle, \quad (6.665)$$

thus

$$L_+ |0, 0\rangle = L_- |0, 0\rangle = 0, \quad (6.666)$$

and consequently

$$\exp\left(-\frac{iL_x\phi}{\hbar}\right) |\psi_0\rangle = |\psi_0\rangle, \quad (6.667)$$

thus

$$A_x(\phi) = \langle \psi_0 | \mathcal{H} | \psi_0 \rangle = E_{0,0} = 0. \quad (6.668)$$

49. The wavefunction of a point particle is given by

$$\psi(\mathbf{r}) = (x + y + 2z) f(r), \quad (6.669)$$

where $f(r)$ is a function of the radial coordinate $r = \sqrt{x^2 + y^2 + z^2}$. As can be seen from Eqs. (6.131) and (6.132), which are given by

$$Y_1^{\pm 1}(\theta, \phi) = \mp \sqrt{\frac{3}{8\pi}} \sin \theta e^{\pm i\phi}, \quad (6.670)$$

$$Y_1^0(\theta, \phi) = \sqrt{\frac{3}{4\pi}} \cos \theta. \quad (6.671)$$

the following holds

$$x = r \sqrt{\frac{2\pi}{3}} (-Y_1^1 + Y_1^{-1}) \quad (6.672)$$

$$y = ir \sqrt{\frac{2\pi}{3}} (Y_1^1 + Y_1^{-1}) \quad (6.673)$$

$$z = r \sqrt{\frac{4\pi}{3}} Y_1^0. \quad (6.674)$$

and thus

$$\psi(\mathbf{r}) = 2\sqrt{\frac{\pi}{3}} \left[\frac{-1+i}{\sqrt{2}} Y_1^1 + \frac{1+i}{\sqrt{2}} Y_1^{-1} + 2Y_1^0 \right] r f(r) . \quad (6.675)$$

- a) In a measurement of \mathbf{L}^2 the only possible outcome is $2\hbar^2$.
 b) In a measurement of L_z the outcome \hbar and $-\hbar$ have both probability $1/6$, whereas the outcome 0 has probability $2/3$.
50. The notation $|\eta_1, \eta_2\rangle$ is used to label the common eigenvectors of the operator $S_{1z}, S_{2z}, \mathbf{S}_1^2$ and \mathbf{S}_2^2 , where $\eta_1 \in \{+, -\}$ and $\eta_2 \in \{+, -\}$. The following holds [see Eqs. (6.69) and (6.70)]

$$S_{1z} |\eta_1, \eta_2\rangle = \eta_1 \frac{\hbar}{2} |\eta_1, \eta_2\rangle , \quad (6.676)$$

$$S_{2z} |\eta_1, \eta_2\rangle = \eta_2 \frac{\hbar}{2} |\eta_1, \eta_2\rangle , \quad (6.677)$$

and

$$\mathbf{S}_1^2 |\eta_1, \eta_2\rangle = \mathbf{S}_2^2 |\eta_1, \eta_2\rangle = \frac{3\hbar^2}{4} |\eta_1, \eta_2\rangle . \quad (6.678)$$

- a) The following holds

$$\mathbf{S}^2 = \mathbf{S}_1^2 + \mathbf{S}_2^2 + \mathbf{S}_1 \cdot \mathbf{S}_2 + \mathbf{S}_2 \cdot \mathbf{S}_1 . \quad (6.679)$$

Any operator of the first particle commutes with any operator of the second one thus

$$\begin{aligned} \mathbf{S}^2 &= \mathbf{S}_1^2 + \mathbf{S}_2^2 + 2\mathbf{S}_1 \cdot \mathbf{S}_2 \\ &= \mathbf{S}_1^2 + \mathbf{S}_2^2 + 2(S_{1x}S_{2x} + S_{1y}S_{2y} + S_{1z}S_{2z}) . \end{aligned} \quad (6.680)$$

In terms of the operators $S_{1\pm}$ and $S_{2\pm}$, which are related to S_{1x}, S_{2x}, S_{1y} and S_{2y} by

$$S_{1x} = \frac{S_{1+} + S_{1-}}{2}, S_{1y} = \frac{S_{1+} - S_{1-}}{2i} , \quad (6.681)$$

$$S_{2x} = \frac{S_{2+} + S_{2-}}{2}, S_{2y} = \frac{S_{2+} - S_{2-}}{2i} , \quad (6.682)$$

\mathbf{S}^2 is given by

$$\mathbf{S}^2 = \mathbf{S}_1^2 + \mathbf{S}_2^2 + S_{1+}S_{2-} + S_{1-}S_{2+} + 2S_{1z}S_{2z} . \quad (6.683)$$

With the help Eqs. (6.24) and (6.41) one finds that

$$\begin{aligned} [\mathbf{S}^2, S_z] &= [\mathbf{S}_1^2 + \mathbf{S}_2^2 + S_{1+}S_{2-} + S_{1-}S_{2+} + 2S_{1z}S_{2z}, S_{1z} + S_{2z}] \\ &= [S_{1+}S_{2-} + S_{1-}S_{2+}, S_{1z} + S_{2z}] \\ &= [S_{1+}, S_{1z}] S_{2-} + [S_{1-}, S_{1z}] S_{2+} + S_{1+} [S_{2-}, S_{2z}] + S_{1-} [S_{2+}, S_{2z}] \\ &= \hbar(-S_{1+}S_{2-} + S_{1-}S_{2+} + S_{1+}S_{2-} - S_{1-}S_{2+}) , \end{aligned} \quad (6.684)$$

thus

$$[\mathbf{S}^2, S_z] = 0. \quad (6.685)$$

b) The following holds [see Eqs. (6.71) and (6.72)]

$$\mathbf{S}^2 \begin{pmatrix} |+, +\rangle \\ |+, -\rangle \\ |-, +\rangle \\ |-, -\rangle \end{pmatrix} = \hbar^2 \begin{pmatrix} 2 & 0 & 0 & 0 \\ 0 & 1 & 1 & 0 \\ 0 & 1 & 1 & 0 \\ 0 & 0 & 0 & 2 \end{pmatrix} \begin{pmatrix} |+, +\rangle \\ |+, -\rangle \\ |-, +\rangle \\ |-, -\rangle \end{pmatrix}, \quad (6.686)$$

and

$$S_z \begin{pmatrix} |+, +\rangle \\ |+, -\rangle \\ |-, +\rangle \\ |-, -\rangle \end{pmatrix} = \hbar \begin{pmatrix} 1 & 0 & 0 & 0 \\ 0 & 0 & 0 & 0 \\ 0 & 0 & 0 & 0 \\ 0 & 0 & 0 & -1 \end{pmatrix} \begin{pmatrix} |+, +\rangle \\ |+, -\rangle \\ |-, +\rangle \\ |-, -\rangle \end{pmatrix}. \quad (6.687)$$

It is thus easy to show that the following set of 4 ket vectors

$$|S = 0, M = 0\rangle = \frac{|+, -\rangle - |-, +\rangle}{\sqrt{2}}, \quad (6.688)$$

$$|S = 1, M = 1\rangle = |+, +\rangle, \quad (6.689)$$

$$|S = 1, M = 0\rangle = \frac{|+, -\rangle + |-, +\rangle}{\sqrt{2}}, \quad (6.690)$$

$$|S = 1, M = -1\rangle = |-, -\rangle, \quad (6.691)$$

forms the desired complete and orthonormal basis of common eigenvectors of \mathbf{S}^2 and S_z , and the following holds

$$\mathbf{S}^2 |S, M\rangle = S(S+1)\hbar^2 |S, M\rangle, \quad (6.692)$$

$$S_z |S, M\rangle = M\hbar |S, M\rangle. \quad (6.693)$$

Note that with the help of Eqs. (6.301) and (6.302) one can show that the state $|S = 0, M = 0\rangle$ [see Eq. (6.688)] can be expressed as

$$|S = 0, M = 0\rangle = \frac{|+; \hat{\mathbf{u}}, -; \hat{\mathbf{u}}\rangle - |-; \hat{\mathbf{u}}, +; \hat{\mathbf{u}}\rangle}{\sqrt{2}}, \quad (6.694)$$

where $\hat{\mathbf{u}} = (\sin \theta \cos \varphi, \sin \theta \sin \varphi, \cos \theta)$ is an arbitrary unit vector.

51. Recall that the states $|S, M\rangle$ are eigenvectors of the operator \mathbf{S}^2 [see Eq. (6.692), which reads $\mathbf{S}^2 |S, M\rangle = S(S+1)\hbar^2 |S, M\rangle$], where $\mathbf{S} = \mathbf{S}_1 + \mathbf{S}_2$, and that $\mathbf{S}_1^2 = \mathbf{S}_2^2 = 3\hbar^2/4$ [see Eq. (6.69)], thus

$$\mathbf{S}^2 = \frac{3\hbar^2}{2} + 2\mathbf{S}_1 \cdot \mathbf{S}_2. \quad (6.695)$$

a) Using Eqs. (6.692) and (6.695) one finds that

$$(\mathbf{S}_1 \cdot \mathbf{S}_2) |S, M\rangle = \frac{\hbar^2}{4} (2S(S+1) - 3) |S, M\rangle. \quad (6.696)$$

b) The following holds [see Eqs. (6.247) and (6.696)]

$$X |S, M\rangle = (S(S+1) - 1) |S, M\rangle , \quad (6.697)$$

where $S(S+1) - 1 = -1$ for $S = 0$, and $S(S+1) - 1 = 1$ for $S = 1$. As can be seen from Eqs. (6.688), (6.689), (6.690) and (6.691), X exchanges the first and second spins.

c) The eigenvalues of X are ± 1 , thus $(X-1)(X+1) = 0$, thus [see Eq. (6.247)]

$$\left(\frac{1 + \frac{4}{\hbar^2} \mathbf{S}_1 \cdot \mathbf{S}_2}{2} - 1 \right) \left(\frac{1 + \frac{4}{\hbar^2} \mathbf{S}_1 \cdot \mathbf{S}_2}{2} + 1 \right) = 0 , \quad (6.698)$$

hence Eq. (6.248) holds.

52. The matrix representation in the basis $\{|+, +\rangle, |+, -\rangle, |-, +\rangle, |-, -\rangle\}$ of the bra vector $\langle \delta |$ and of the operators $(2/\hbar) \mathbf{S}_1 \cdot \hat{\mathbf{u}}_1$ and $(2/\hbar) \mathbf{S}_2 \cdot \hat{\mathbf{u}}_2$ are given by

$$\langle \delta | \doteq \left(0 \quad \frac{1}{\sqrt{2}} \quad \frac{-e^{-i\delta}}{\sqrt{2}} \quad 0 \right) , \quad (6.699)$$

and [see Eqs. (6.301) and (6.302)]

$$\frac{2}{\hbar} \mathbf{S}_1 \cdot \hat{\mathbf{u}}_1 \doteq \begin{pmatrix} \cos \theta_1 & 0 & \sin \theta_1 e^{-i\varphi_1} & 0 \\ 0 & \cos \theta_1 & 0 & \sin \theta_1 e^{-i\varphi_1} \\ \sin \theta_1 e^{i\varphi_1} & 0 & -\cos \theta_1 & 0 \\ 0 & \sin \theta_1 e^{i\varphi_1} & 0 & -\cos \theta_1 \end{pmatrix} , \quad (6.700)$$

$$\frac{2}{\hbar} \mathbf{S}_2 \cdot \hat{\mathbf{u}}_2 \doteq \begin{pmatrix} \cos \theta_2 & \sin \theta_2 e^{-i\varphi_2} & 0 & 0 \\ \sin \theta_2 e^{i\varphi_2} & -\cos \theta_2 & 0 & 0 \\ 0 & 0 & \cos \theta_2 & \sin \theta_2 e^{-i\varphi_2} \\ 0 & 0 & \sin \theta_2 e^{i\varphi_2} & -\cos \theta_2 \end{pmatrix} . \quad (6.701)$$

With the help of the above results one finds that

$$\frac{2}{\hbar} \langle \mathbf{S}_1 \cdot \hat{\mathbf{u}}_1 \rangle = \frac{2}{\hbar} \langle \mathbf{S}_2 \cdot \hat{\mathbf{u}}_2 \rangle = 0 , \quad (6.702)$$

and

$$\begin{aligned} & (2/\hbar)^2 \langle (\mathbf{S}_1 \cdot \hat{\mathbf{u}}_1) (\mathbf{S}_2 \cdot \hat{\mathbf{u}}_2) \rangle \\ &= -\sin \theta_1 \sin \theta_2 \cos(\varphi_1 - \varphi_2 - \delta) - \cos \theta_1 \cos \theta_2 . \end{aligned} \quad (6.703)$$

The above result (6.703) can be rewritten as

$$(2/\hbar)^2 \langle (\mathbf{S}_1 \cdot \hat{\mathbf{u}}_1) (\mathbf{S}_2 \cdot \hat{\mathbf{u}}_2) \rangle = -\hat{\mathbf{u}}_1 \cdot (R_{\hat{\mathbf{z}}} \hat{\mathbf{u}}_2) , \quad (6.704)$$

where the rotation matrix $R_{\hat{\mathbf{z}}}$ is given by [see Eq. (6.10)]

$$R_{\hat{\mathbf{z}}} = \begin{pmatrix} \cos \delta & -\sin \delta & 0 \\ \sin \delta & \cos \delta & 0 \\ 0 & 0 & 1 \end{pmatrix}. \quad (6.705)$$

53. With the help of the identity [see Eq. (6.683)]

$$S_{1x}S_{2x} + S_{1y}S_{2y} = \frac{S_{1+}S_{2-} + S_{1-}S_{2+}}{2}, \quad (6.706)$$

where

$$S_{n\pm} = S_{nx} \pm iS_{ny}, \quad (6.707)$$

one finds that the Hamiltonian (6.252) can be rewritten as

$$\mathcal{H} = \frac{\omega}{\hbar} \left[\frac{S_{1+}S_{2-} + S_{1-}S_{2+}}{2} + (1 + \eta) S_{1z}S_{2z} \right]. \quad (6.708)$$

Let $|\eta_1, \eta_2\rangle$ be a normalized common eigenvectors of the operator S_{1z} and S_{2z} with eigenvalues $\eta_1 (\hbar/2)$ and $\eta_2 (\hbar/2)$, respectively, where $\eta_1 \in \{+, -\}$ and $\eta_2 \in \{+, -\}$. The following holds [see Eqs. (6.70), (6.71), (6.72) and (6.708)]

$$\mathcal{H} \begin{pmatrix} |+, +\rangle \\ |+, -\rangle \\ |-, +\rangle \\ |-, -\rangle \end{pmatrix} = H \begin{pmatrix} |+, +\rangle \\ |+, -\rangle \\ |-, +\rangle \\ |-, -\rangle \end{pmatrix}, \quad (6.709)$$

where

$$H = \frac{\hbar\omega}{4} \begin{pmatrix} 1 + \eta & 0 & 0 & 0 \\ 0 & -1 - \eta & 2 & 0 \\ 0 & 2 & -1 - \eta & 0 \\ 0 & 0 & 0 & 1 + \eta \end{pmatrix}. \quad (6.710)$$

The 4×4 matrix H can be diagonalized using the transformation

$$U^{-1}HU = \begin{pmatrix} E_{1,1} & 0 & 0 & 0 \\ 0 & E_{1,0} & 0 & 0 \\ 0 & 0 & E_{0,0} & 0 \\ 0 & 0 & 0 & E_{1,-1} \end{pmatrix}, \quad (6.711)$$

where the unitary matrix U is given by

$$U = \begin{pmatrix} 1 & 0 & 0 & 0 \\ 0 & \frac{1}{\sqrt{2}} & \frac{1}{\sqrt{2}} & 0 \\ 0 & \frac{1}{\sqrt{2}} & -\frac{1}{\sqrt{2}} & 0 \\ 0 & 0 & 0 & 1 \end{pmatrix}, \quad (6.712)$$

and where the eigenenergies are given by

$$E_{1,1} = \frac{(1 + \eta) \hbar \omega}{4}, \quad (6.713)$$

$$E_{1,0} = \frac{(1 - \eta) \hbar \omega}{4}, \quad (6.714)$$

$$E_{0,0} = \frac{(-3 - \eta) \hbar \omega}{4}, \quad (6.715)$$

$$E_{1,-1} = \frac{(1 + \eta) \hbar \omega}{4}. \quad (6.716)$$

Note that the following holds

$$U \begin{pmatrix} |+, +\rangle \\ |+, -\rangle \\ |-, +\rangle \\ |-, -\rangle \end{pmatrix} = \begin{pmatrix} |+, +\rangle \\ \frac{|+, -\rangle + |-, +\rangle}{\sqrt{2}} \\ \frac{|+, -\rangle - |-, +\rangle}{\sqrt{2}} \\ |-, -\rangle \end{pmatrix} = \begin{pmatrix} |S = 1, M = 1\rangle \\ |S = 1, M = 0\rangle \\ |S = 0, M = 0\rangle \\ |S = 1, M = -1\rangle \end{pmatrix}, \quad (6.717)$$

where the states $|S, M\rangle$ are the common eigenvectors of the operators $\mathbf{S}^2 = (\mathbf{S}_1 + \mathbf{S}_2)^2$ and $S_z = S_{1z} + S_{2z}$ given by Eqs. (6.688), (6.689), (6.690) and (6.691). The initial state at time $t = 0$ can be expressed as

$$|\psi(t = 0)\rangle = |+, -\rangle = \frac{|0, 0\rangle + |1, 0\rangle}{\sqrt{2}}, \quad (6.718)$$

and thus for a general time t one has [see Eq. (4.14)]

$$|\psi(t)\rangle = \frac{e^{-\frac{iE_{0,0}t}{\hbar}} |0, 0\rangle + e^{-\frac{iE_{1,0}t}{\hbar}} |1, 0\rangle}{\sqrt{2}}. \quad (6.719)$$

The following holds

$$S_{1z} |0, 0\rangle = \frac{\hbar}{2} |1, 0\rangle, \quad (6.720)$$

$$S_{1z} |1, 0\rangle = \frac{\hbar}{2} |0, 0\rangle, \quad (6.721)$$

$$S_{2z} |0, 0\rangle = -\frac{\hbar}{2} |1, 0\rangle, \quad (6.722)$$

$$S_{2z} |1, 0\rangle = -\frac{\hbar}{2} |0, 0\rangle, \quad (6.723)$$

and thus

$$\langle S_{1z} \rangle(t) = -\langle S_{2z} \rangle(t) = \frac{\hbar}{2} \cos \frac{(E_{1,0} - E_{0,0})t}{\hbar} = \frac{\hbar \cos(\omega t)}{2}. \quad (6.724)$$

54. The following holds [see Eqs. (6.32) and (6.36)]

$$J_{\hat{\mathbf{n}}} = \frac{\sin \theta (e^{-i\varphi} J_+ + e^{i\varphi} J_-)}{2} + \cos \theta J_z, \quad (6.725)$$

thus [see Eqs. (6.63), (6.64), (6.65) and (6.66)]

$$\langle j, m | J_{\hat{n}} | j, m \rangle = m\hbar \cos \theta , \quad (6.726)$$

and [see Eqs. (6.43) and (6.44)]

$$\begin{aligned} \langle j, m | J_{\hat{n}}^2 | j, m \rangle &= \langle j, m | \frac{\sin^2 \theta (J_+ J_- + J_- J_+)}{4} + \cos^2 \theta J_z^2 | j, m \rangle \\ &= \langle j, m | \frac{\sin^2 \theta (\mathbf{J}^2 - J_z^2)}{2} + \cos^2 \theta J_z^2 | j, m \rangle \\ &= \hbar^2 \left[\frac{\sin^2 \theta (j(j+1) - m^2)}{2} + \cos^2 \theta m^2 \right] , \end{aligned} \quad (6.727)$$

thus the expectation value is given by $\langle J_{\hat{n}} \rangle = m\hbar \cos \theta$ and the variance is given by

$$\langle (\Delta J_{\hat{n}})^2 \rangle = \hbar^2 \frac{j(j+1) - m^2}{2} \sin^2 \theta . \quad (6.728)$$

55. Define the vector of operators $\Sigma = (\Sigma_x, \Sigma_y, \Sigma_z)$, where

$$\Sigma_x = \frac{a^{\dagger 2} - a^2}{2} , \quad (6.729)$$

$$\Sigma_y = -i \frac{a^{\dagger 2} + a^2}{2} , \quad (6.730)$$

$$\Sigma_z = \frac{aa^{\dagger} + a^{\dagger}a}{2} . \quad (6.731)$$

Using Eq. (5.13), which is given by

$$[a, a^{\dagger}] = 1 , \quad (6.732)$$

one finds that

$$[\Sigma_x, \Sigma_y] = 2i\Sigma_z , \quad (6.733)$$

$$[\Sigma_y, \Sigma_z] = 2i\Sigma_x , \quad (6.734)$$

$$[\Sigma_z, \Sigma_x] = 2i\Sigma_y , \quad (6.735)$$

thus

$$[\Sigma_i, \Sigma_j] = 2i\varepsilon_{ijk}\Sigma_k , \quad (6.736)$$

where $i, j, k \in \{x, y, z\}$. The operator $S(\xi, \varphi)$ (6.253) can be rewritten as

$$S(\xi, \varphi) = \exp [\xi (e^{i\varphi} \Sigma_+ + e^{-i\varphi} \Sigma_-)] , \quad (6.737)$$

where

$$\Sigma_+ = \frac{1}{2} (\Sigma_x + i\Sigma_y) = \frac{a^{\dagger 2}}{2}, \quad (6.738)$$

$$\Sigma_- = \frac{1}{2} (\Sigma_x - i\Sigma_y) = -\frac{a^2}{2}. \quad (6.739)$$

The vector of Pauli matrices $\boldsymbol{\sigma} = (\sigma_x, \sigma_y, \sigma_z)$ satisfies a similar set of commutation relations $[\sigma_i, \sigma_j] = 2i\varepsilon_{ijk}\sigma_k$ as the set (6.736). Thus, all identities that are derived for the vector of Pauli matrices $\boldsymbol{\sigma} = (\sigma_x, \sigma_y, \sigma_z)$ are applicable for the vector $\boldsymbol{\Sigma} = (\Sigma_x, \Sigma_y, \Sigma_z)$ provided that the derivation uses only the commutation relations $[\sigma_i, \sigma_j] = 2i\varepsilon_{ijk}\sigma_k$. With the help of the identity (6.139) one finds that the 2×2 matrix $s(\xi, \varphi)$, which is defined by [compare with Eq. (6.737)]

$$s(\xi, \varphi) = \exp [\xi (e^{i\varphi}\sigma_+ + e^{-i\varphi}\sigma_-)], \quad (6.740)$$

where

$$\sigma_+ = \frac{1}{2} (\sigma_x + i\sigma_y) = \begin{pmatrix} 0 & 1 \\ 0 & 0 \end{pmatrix}, \quad (6.741)$$

$$\sigma_- = \frac{1}{2} (\sigma_x - i\sigma_y) = \begin{pmatrix} 0 & 0 \\ 1 & 0 \end{pmatrix}, \quad (6.742)$$

is given by

$$s(\xi, \varphi) = \begin{pmatrix} \cosh \xi & e^{i\varphi} \sinh \xi \\ e^{-i\varphi} \sinh \xi & \cosh \xi \end{pmatrix}. \quad (6.743)$$

Furthermore, with the help of the following matrix identity

$$\begin{aligned} & \begin{pmatrix} \cosh \xi & e^{i\varphi} \sinh \xi \\ e^{-i\varphi} \sinh \xi & \cosh \xi \end{pmatrix} \\ &= \begin{pmatrix} 1 & e^{i\varphi} \tanh \xi \\ 0 & 1 \end{pmatrix} \\ &\times \begin{pmatrix} e^{-\log(\cosh \xi)} & 0 \\ 0 & e^{\log(\cosh \xi)} \end{pmatrix} \\ &\times \begin{pmatrix} 1 & 0 \\ e^{-i\varphi} \tanh \xi & 1 \end{pmatrix}, \end{aligned} \quad (6.744)$$

and the relations $\sigma_+^2 = \sigma_-^2 = 0$ one has

$$\begin{aligned} & s(\xi, \varphi) \\ &= \exp(e^{i\varphi} \tanh \xi \sigma_+) \\ &\times \exp(-\log(\cosh \xi) \sigma_z) \\ &\times \exp(e^{-i\varphi} \tanh \xi \sigma_-). \end{aligned} \quad (6.745)$$

The above expression for $s(\xi, \varphi)$ yields a similar identity for the operator $S(\xi, \varphi)$

$$\begin{aligned} S(\xi, \varphi) &= \exp\left(\frac{e^{i\varphi}}{2} a^{\dagger 2} \tanh \xi\right) \\ &\times \exp\left(-\frac{\log(\cosh \xi)}{2} (aa^\dagger + a^\dagger a)\right) \\ &\times \exp\left(-\frac{e^{-i\varphi}}{2} a^2 \tanh \xi\right). \end{aligned} \quad (6.746)$$

56. With the help of Eqs. (5.362) and (5.113) one finds that

$$\begin{aligned} Q(\mu) &= \frac{1}{x_0 \sqrt{\pi \mu}} \int_{-\infty}^{\infty} dx' \\ &\times \exp\left(-\frac{x'^2}{2\mu^2 x_0^2} + \sqrt{2} \frac{x'}{\mu x_0} a^\dagger - \frac{a^{\dagger 2}}{2}\right) \\ &\times : \exp(-a^\dagger a) : \\ &\times \exp\left(-\frac{x'^2}{2x_0^2} + \sqrt{2} \frac{x'}{x_0} a - \frac{a^2}{2}\right). \end{aligned} \quad (6.747)$$

Since the integrated function is in normal ordering the integration can be performed while disregarding the nonvanishing commutation relation between a and a^\dagger , namely by treating these operators as if they were c-numbers

$$\begin{aligned} Q(\mu) &= \frac{1}{x_0 \sqrt{\pi \mu}} \int_{-\infty}^{\infty} dx' \\ &\times : e^{-\frac{(1+\frac{1}{\mu^2})x'^2}{2x_0^2} + \frac{\sqrt{2}(a+\frac{a^\dagger}{\mu})x'}{x_0} - \frac{(a+a^\dagger)^2}{2}} : , \end{aligned} \quad (6.748)$$

or with the help of the identity (5.149) one finds that

$$\begin{aligned} Q(\mu) &= \sqrt{\frac{2\mu}{1+\mu^2}} : e^{\frac{(a+\frac{a^\dagger}{\mu})^2}{1+\frac{1}{\mu^2}} - \frac{(a+a^\dagger)^2}{2}} : \\ &= \sqrt{\frac{2\mu}{1+\mu^2}} : e^{\frac{1-\mu^2}{1+\mu^2} \frac{a^{\dagger 2} - a^2}{2} - \frac{(1-\mu)^2}{1+\mu^2} aa^\dagger} : . \end{aligned} \quad (6.749)$$

Thus, using the notation

$$\mu = e^{-\xi}, \quad (6.750)$$

and the identities

$$\frac{1 - e^{-2\xi}}{1 + e^{-2\xi}} = \tanh \xi, \quad (6.751)$$

$$\frac{2e^{-\xi}}{1 + e^{-2\xi}} = \frac{1}{\cosh \xi}, \quad (6.752)$$

$$\frac{(1 - e^{-\xi})^2}{1 + e^{-2\xi}} = 1 - \frac{1}{\cosh \xi}, \quad (6.753)$$

one has

$$\begin{aligned} Q(\mu) &= \sqrt{\frac{2\mu}{1+\mu^2}} : e^{-\tanh \xi \frac{a^2 - a^{\dagger 2}}{2} + (\frac{1}{\cosh \xi} - 1)aa^\dagger} : \\ &= \sqrt{\frac{1}{\cosh \xi}} e^{\frac{\tanh \xi}{2} a^{\dagger 2}} : e^{(\frac{1}{\cosh \xi} - 1)aa^\dagger} : e^{-\frac{\tanh \xi}{2} a^2}. \end{aligned} \quad (6.754)$$

This can be further simplified with the help of Eq. (5.112)

$$Q(\mu) = \sqrt{\frac{1}{\cosh \xi}} e^{\frac{\tanh \xi}{2} a^{\dagger 2}} e^{-\log(\cosh \xi)aa^\dagger} e^{-\frac{\tanh \xi}{2} a^2}. \quad (6.755)$$

Using also

$$\sqrt{\frac{1}{\cosh \xi}} = e^{-\frac{1}{2} \log(\cosh \xi)}$$

and

$$a^\dagger a + \frac{1}{2} = \frac{aa^\dagger + a^\dagger a}{2}$$

one has

$$Q(\mu) = e^{\frac{\tanh \xi}{2} a^{\dagger 2}} e^{-\frac{\log(\cosh \xi)}{2}(aa^\dagger + a^\dagger a)} e^{-\frac{\tanh \xi}{2} a^2}. \quad (6.756)$$

The last result together with Eq. (6.255) leads to

$$S(\xi, 0) = Q(e^{-\xi}). \quad (6.757)$$

7. Central Potential

Consider a particle having mass m in a central potential, namely a potential $V(r)$ that depends only on the distance

$$r = \sqrt{x^2 + y^2 + z^2} \quad (7.1)$$

from the origin. The Hamiltonian is given by

$$\mathcal{H} = \frac{\mathbf{p}^2}{2m} + V(r) . \quad (7.2)$$

Exercise 7.0.1. Show that

$$[\mathcal{H}, L_z] = 0 , \quad (7.3)$$

$$[\mathcal{H}, \mathbf{L}^2] = 0 . \quad (7.4)$$

Solution 7.0.1. Using

$$[x_i, p_j] = i\hbar\delta_{ij} , \quad (7.5)$$

$$L_z = xp_y - yp_x , \quad (7.6)$$

one has

$$\begin{aligned} [\mathbf{p}^2, L_z] &= [p_x^2, L_z] + [p_y^2, L_z] + [p_z^2, L_z] \\ &= [p_x^2, xp_y] - [p_y^2, yp_x] \\ &= i\hbar(-2p_xp_y + 2p_y p_x) \\ &= 0 , \end{aligned} \quad (7.7)$$

and

$$\begin{aligned} [\mathbf{r}^2, L_z] &= [x^2, L_z] + [y^2, L_z] + [z^2, L_z] \\ &= -y[x^2, p_x] + [y^2, p_y]x \\ &= 0 . \end{aligned} \quad (7.8)$$

Thus L_z commutes with any smooth function of \mathbf{r}^2 , and consequently $[\mathcal{H}, L_z] = 0$. In a similar way one can show that $[\mathcal{H}, L_x] = [\mathcal{H}, L_y] = 0$, and therefore $[\mathcal{H}, \mathbf{L}^2] = 0$.

In classical physics the corresponding Poisson's brackets relations hold

$$\{\mathcal{H}, L_x\} = \{\mathcal{H}, L_y\} = \{\mathcal{H}, L_z\} = 0, \quad (7.9)$$

and

$$\{\mathcal{H}, \mathbf{L}^2\} = 0. \quad (7.10)$$

These relations imply that classically the angular momentum is a *constant of the motion* [see Eq. (1.40)]. On the other hand, in quantum mechanics, as we have seen in section 2.12 of chapter 2, the commutation relations

$$[\mathcal{H}, L_z] = 0, \quad (7.11)$$

$$[\mathcal{H}, \mathbf{L}^2] = 0, \quad (7.12)$$

imply that it is possible to find a basis for the vector space made of common eigenvectors of the operators \mathcal{H} , \mathbf{L}^2 and L_z .

7.1 Simultaneous Diagonalization of the Operators \mathcal{H} , \mathbf{L}^2 and L_z

We start by proving some useful relations:

Exercise 7.1.1. Show that

$$\mathbf{L}^2 = \mathbf{r}^2 \mathbf{p}^2 - (\mathbf{r} \cdot \mathbf{p})^2 + i\hbar \mathbf{r} \cdot \mathbf{p}. \quad (7.13)$$

Solution 7.1.1. The following holds

$$\begin{aligned} L_z^2 &= (xp_y - yp_x)^2 \\ &= x^2 p_y^2 + y^2 p_x^2 - xp_y yp_x - yp_x xp_y \\ &= x^2 p_y^2 + y^2 p_x^2 - xp_x ([p_y, y] + yp_y) - yp_y ([p_x, x] + xp_x) \\ &= x^2 p_y^2 + y^2 p_x^2 - xp_x yp_y - yp_y xp_x + i\hbar (xp_x + yp_y). \end{aligned} \quad (7.14)$$

Using the relation

$$xp_x xp_x = x ([p_x, x] + xp_x) p_x = -i\hbar xp_x + x^2 p_x^2, \quad (7.15)$$

or

$$i\hbar xp_x = x^2 p_x^2 - xp_x xp_x, \quad (7.16)$$

one has

7.1. Simultaneous Diagonalization of the Operators \mathcal{H} , \mathbf{L}^2 and L_z

$$\begin{aligned}
 L_z^2 &= x^2 p_y^2 + y^2 p_x^2 - x p_x y p_y - y p_y x p_x + \frac{i\hbar}{2} (x p_x + y p_y) \\
 &\quad + \frac{1}{2} (x^2 p_x^2 - x p_x x p_x + y^2 p_y^2 - y p_y y p_y) .
 \end{aligned} \tag{7.17}$$

By cyclic permutation one obtains similar expression for L_x^2 and for L_y^2 . Combining these expressions lead to

$$\begin{aligned}
 \mathbf{L}^2 &= L_x^2 + L_y^2 + L_z^2 \\
 &= y^2 p_z^2 + z^2 p_y^2 - y p_y z p_z - z p_z y p_y + \frac{i\hbar}{2} (y p_y + z p_z) + \frac{1}{2} (y^2 p_y^2 - y p_y y p_y + z^2 p_z^2 - z p_z z p_z) \\
 &\quad + z^2 p_x^2 + x^2 p_z^2 - z p_z x p_x - x p_x z p_z + \frac{i\hbar}{2} (z p_z + x p_x) + \frac{1}{2} (z^2 p_z^2 - z p_z z p_z + x^2 p_x^2 - x p_x x p_x) \\
 &\quad + x^2 p_y^2 + y^2 p_x^2 - x p_x y p_y - y p_y x p_x + \frac{i\hbar}{2} (x p_x + y p_y) + \frac{1}{2} (x^2 p_x^2 - x p_x x p_x + y^2 p_y^2 - y p_y y p_y) \\
 &= (x^2 + y^2 + z^2) (p_x^2 + p_y^2 + p_z^2) - (x p_x + y p_y + z p_z)^2 + i\hbar (x p_x + y p_y + z p_z) \\
 &= \mathbf{r}^2 \mathbf{p}^2 - (\mathbf{r} \cdot \mathbf{p})^2 + i\hbar \mathbf{r} \cdot \mathbf{p} .
 \end{aligned} \tag{7.18}$$

Exercise 7.1.2. Show that

$$\langle \mathbf{r}' | \mathbf{p}^2 | \alpha \rangle = -\hbar^2 \left(\frac{1}{r'} \frac{\partial^2}{\partial r'^2} r' \langle \mathbf{r}' | \alpha \rangle - \frac{1}{\hbar^2 r'^2} \langle \mathbf{r}' | \mathbf{L}^2 | \alpha \rangle \right) . \tag{7.19}$$

Solution 7.1.2. Using the identities

$$\mathbf{L}^2 = \mathbf{r}^2 \mathbf{p}^2 - (\mathbf{r} \cdot \mathbf{p})^2 + i\hbar \mathbf{r} \cdot \mathbf{p} , \tag{7.20}$$

$$\langle \mathbf{r}' | \mathbf{r} | \alpha \rangle = \mathbf{r}' \langle \mathbf{r}' | \alpha \rangle , \tag{7.21}$$

and

$$\langle \mathbf{r}' | \mathbf{p} | \alpha \rangle = \frac{\hbar}{i} \nabla \langle \mathbf{r}' | \alpha \rangle , \tag{7.22}$$

one finds that

$$\langle \mathbf{r}' | \mathbf{L}^2 | \alpha \rangle = \langle \mathbf{r}' | \mathbf{r}^2 \mathbf{p}^2 | \alpha \rangle - \langle \mathbf{r}' | (\mathbf{r} \cdot \mathbf{p})^2 | \alpha \rangle + i\hbar \langle \mathbf{r}' | \mathbf{r} \cdot \mathbf{p} | \alpha \rangle . \tag{7.23}$$

The following hold

$$\langle \mathbf{r}' | \mathbf{r} \cdot \mathbf{p} | \alpha \rangle = -i\hbar \mathbf{r}' \cdot \nabla \langle \mathbf{r}' | \alpha \rangle = -i\hbar r' \frac{\partial}{\partial r'} \langle \mathbf{r}' | \alpha \rangle , \tag{7.24}$$

$$\begin{aligned}
 \langle \mathbf{r}' | (\mathbf{r} \cdot \mathbf{p})^2 | \alpha \rangle &= -\hbar^2 \left(r' \frac{\partial}{\partial r'} \right)^2 \langle \mathbf{r}' | \alpha \rangle \\
 &= -\hbar^2 \left(r'^2 \frac{\partial^2}{\partial r'^2} + r' \frac{\partial}{\partial r'} \right) \langle \mathbf{r}' | \alpha \rangle ,
 \end{aligned} \tag{7.25}$$

$$\langle \mathbf{r}' | \mathbf{r}^2 \mathbf{p}^2 | \alpha \rangle = r'^2 \langle \mathbf{r}' | \mathbf{p}^2 | \alpha \rangle , \quad (7.26)$$

thus

$$\langle \mathbf{r}' | \mathbf{p}^2 | \alpha \rangle = -\hbar^2 \left[\left(\frac{\partial^2}{\partial r'^2} + \frac{2}{r'} \frac{\partial}{\partial r'} \right) \langle \mathbf{r}' | \alpha \rangle - \frac{1}{\hbar^2 r'^2} \langle \mathbf{r}' | \mathbf{L}^2 | \alpha \rangle \right] , \quad (7.27)$$

or

$$\langle \mathbf{r}' | \mathbf{p}^2 | \alpha \rangle = -\hbar^2 \left(\frac{1}{r'} \frac{\partial^2}{\partial r'^2} r' \langle \mathbf{r}' | \alpha \rangle - \frac{1}{\hbar^2 r'^2} \langle \mathbf{r}' | \mathbf{L}^2 | \alpha \rangle \right) . \quad (7.28)$$

The time-independent Schrödinger equation in the coordinates representation

$$\langle \mathbf{r}' | \mathcal{H} | \alpha \rangle = E \langle \mathbf{r}' | \alpha \rangle , \quad (7.29)$$

where the Hamiltonian \mathcal{H} is given by Eq. (7.2), can thus be written using the above results as

$$\langle \mathbf{r}' | \mathcal{H} | \alpha \rangle = \frac{-\hbar^2}{2m} \left[\frac{1}{r'} \frac{\partial^2}{\partial r'^2} r' \langle \mathbf{r}' | \alpha \rangle - \frac{1}{\hbar^2 r'^2} \langle \mathbf{r}' | \mathbf{L}^2 | \alpha \rangle \right] + V(r') \langle \mathbf{r}' | \alpha \rangle . \quad (7.30)$$

7.2 The Radial Equation

Consider a solution having the form

$$\langle \mathbf{r}' | \alpha \rangle = \varphi(\mathbf{r}') = R(r') Y_l^m(\theta', \phi') . \quad (7.31)$$

With the help of Eq. (6.107) one finds that

$$\langle \mathbf{r}' | \mathbf{L}^2 | \alpha \rangle = \hbar^2 l(l+1) \varphi(\mathbf{r}') . \quad (7.32)$$

Substituting into Eq. (7.30) yields an equation for $R(r)$

$$\frac{-\hbar^2}{2m} \left[\frac{1}{r} \frac{d^2}{dr^2} r R(r) - \frac{1}{r^2} l(l+1) R(r) \right] + V(r) R(r) = E R(r) . \quad (7.33)$$

The above equation, which is called the *radial equation*, depends on the quantum number l , however, it is independent on the quantum number m . The different solutions for a given l are labeled using the index k

$$\frac{-\hbar^2}{2m} \left[\frac{1}{r} \frac{d^2}{dr^2} r R_{kl} - \frac{1}{r^2} l(l+1) R_{kl} \right] + V R_{kl} = E R_{kl} . \quad (7.34)$$

It is convenient to introduce the function $u_{kl}(r)$, which is related to $R_{kl}(r)$ by the following relation

$$R_{kl}(r) = \frac{1}{r} u_{kl}(r) . \quad (7.35)$$

Substituting into Eq. (7.34) yields an equation for $u_{kl}(r)$

$$\left(\frac{-\hbar^2}{2m} \frac{d^2}{dr^2} + V_{\text{eff}}(r) \right) u_{kl}(r) = E_{kl} u_{kl}(r) , \quad (7.36)$$

where the effective potential $V_{\text{eff}}(r)$ is given by

$$V_{\text{eff}}(r) = \frac{l(l+1)\hbar^2}{2mr^2} + V(r) . \quad (7.37)$$

The total wave function is thus given by

$$\varphi_{klm}(\mathbf{r}) = \frac{1}{r} u_{kl}(r) Y_l^m(\theta, \phi) . \quad (7.38)$$

Since the spherical harmonic $Y_l^m(\theta, \phi)$ is assumed to be normalized [see Eq. (6.114)], to ensure that $\varphi_{klm}(\mathbf{r})$ is normalized we require that

$$1 = \int_0^\infty dr r^2 |R_{kl}(r)|^2 = \int_0^\infty dr |u_{kl}(r)|^2 . \quad (7.39)$$

In addition solutions with different k are expected to be orthogonal, thus

$$\int_0^\infty dr u_{k'l}^*(r) u_{kl}(r) = \delta_{kk'} . \quad (7.40)$$

The wave functions $\varphi_{klm}(\mathbf{r})$ represent common eigenstates of the operators \mathcal{H} , L_z and \mathbf{L}^2 , which are denoted as $|klm\rangle$ and which satisfy the following relations

$$\varphi_{klm}(\mathbf{r}') = \langle \mathbf{r}' | klm \rangle , \quad (7.41)$$

and

$$\mathcal{H} |klm\rangle = E_{kl} |klm\rangle , \quad (7.42)$$

$$\mathbf{L}^2 |klm\rangle = l(l+1)\hbar^2 |klm\rangle , \quad (7.43)$$

$$L_z |klm\rangle = m\hbar |klm\rangle . \quad (7.44)$$

The following claim reveals an important property of the radial wavefunction near the origin ($r = 0$):

Claim. If the potential energy $V(r)$ does not diverge more rapidly than $1/r$ near the origin then

$$\lim_{r \rightarrow 0} u(r) = 0 . \quad (7.45)$$

Proof. Consider the case where near the origin $u(r)$ has a dominant power term having the form r^s (namely, all other terms are of order higher than s , and thus become negligibly small for sufficiently small r). Substituting into Eq. (7.36) and keeping only the dominant terms (of lowest order in r) lead to

$$\frac{-\hbar^2}{2m}s(s-1)r^{s-2} + \frac{l(l+1)\hbar^2}{2m}r^{s-2} = 0, \quad (7.46)$$

thus $s = -l$ or $s = l + 1$. However, the solution $s = -l$ for $l \geq 1$ must be rejected since for this case the normalization condition (7.39) cannot be satisfied as the integral diverges near $r = 0$. Moreover, also for $l = 0$ the solution $s = -l$ must be rejected. For this case $\varphi(\mathbf{r}) \simeq 1/r$ near the origin, however, such a solution contradicts Eq. (7.30), which can be written as

$$-\frac{\hbar^2}{2m}\nabla^2\varphi(\mathbf{r}) + V(r)\varphi(\mathbf{r}) = E\varphi(\mathbf{r}). \quad (7.47)$$

since

$$\nabla^2\frac{1}{r} = -4\pi\delta(\mathbf{r}). \quad (7.48)$$

We thus conclude that only the solution $s = l + 1$ is acceptable, and consequently $\lim_{r \rightarrow 0} u(r) = 0$.

7.3 Hydrogen Atom

The hydrogen atom is made of two particles, an electron and a proton. It is convenient to employ the center of mass coordinates system. As is shown below, in this reference frame the two body problem is reduced into a central potential problem of effectively a single particle.

Exercise 7.3.1. Consider two point particles having mass m_1 and m_2 respectively. The potential energy $V(\mathbf{r})$ depends only on the relative coordinate $\mathbf{r} = \mathbf{r}_1 - \mathbf{r}_2$. Show that the Hamiltonian of the system in the center of mass frame is given by

$$\mathcal{H} = \frac{\mathbf{p}^2}{2\mu} + V(\mathbf{r}), \quad (7.49)$$

where the reduced mass μ is given by

$$\mu = \frac{m_1 m_2}{m_1 + m_2}. \quad (7.50)$$

Solution 7.3.1. The Lagrangian is given by

$$\mathcal{L} = \frac{m_1 \dot{\mathbf{r}}_1^2}{2} + \frac{m_2 \dot{\mathbf{r}}_2^2}{2} - V(\mathbf{r}_1 - \mathbf{r}_2) . \quad (7.51)$$

In terms of center of mass \mathbf{r}_0 and relative \mathbf{r} coordinates, which are given by

$$\mathbf{r}_0 = \frac{m_1 \mathbf{r}_1 + m_2 \mathbf{r}_2}{m_1 + m_2} , \quad (7.52)$$

$$\mathbf{r} = \mathbf{r}_1 - \mathbf{r}_2 , \quad (7.53)$$

the Lagrangian is given by

$$\begin{aligned} \mathcal{L} &= \frac{m_1 \left(\dot{\mathbf{r}}_0 + \frac{m_2}{m_1 + m_2} \dot{\mathbf{r}} \right)^2}{2} + \frac{m_2 \left(\dot{\mathbf{r}}_0 - \frac{m_1}{m_1 + m_2} \dot{\mathbf{r}} \right)^2}{2} - V(\mathbf{r}) \\ &= \frac{M \dot{\mathbf{r}}_0^2}{2} + \frac{\mu \dot{\mathbf{r}}^2}{2} - V(\mathbf{r}) , \end{aligned} \quad (7.54)$$

where the total mass M is given by

$$M = m_1 + m_2 , \quad (7.55)$$

and the reduced mass by

$$\mu = \frac{m_1 m_2^2 + m_2 m_1^2}{(m_1 + m_2)^2} = \frac{m_1 m_2}{m_1 + m_2} . \quad (7.56)$$

Note that the Euler Lagrange equation for the coordinate \mathbf{r}_0 yields that $\ddot{\mathbf{r}}_0 = 0$ (since the potential is independent on \mathbf{r}_0). In the center of mass frame $\mathbf{r}_0 = 0$. The momentum canonically conjugate to \mathbf{r} is given by

$$\mathbf{p} = \frac{\partial \mathcal{L}}{\partial \dot{\mathbf{r}}} . \quad (7.57)$$

Thus the Hamiltonian is given by

$$\mathcal{H} = \mathbf{p} \cdot \dot{\mathbf{r}} - \mathcal{L} = \frac{\mathbf{p}^2}{2\mu} + V(\mathbf{r}) . \quad (7.58)$$

For the case of hydrogen atom the potential between the electron having charge $-e$ and the proton having charge e is given by

$$V(r) = -\frac{e^2}{r} . \quad (7.59)$$

Since the proton's mass m_p is significantly larger than the electron's mass m_e ($m_p \simeq 1800m_e$) the reduced mass is very close to m_e

$$\mu = \frac{m_e m_p}{m_e + m_p} \simeq m_e . \quad (7.60)$$

The radial equation (7.36) for the present case is given by

$$\left(\frac{-\hbar^2}{2\mu} \frac{d^2}{dr^2} + V_{\text{eff}}(r) \right) u_{kl}(r) = E_{kl} u_{kl}(r) , \quad (7.61)$$

where

$$V_{\text{eff}}(r) = -\frac{e^2}{r} + \frac{l(l+1)\hbar^2}{2\mu r^2} . \quad (7.62)$$

In terms of the dimensionless radial coordinate

$$\rho = \frac{r}{a_0} , \quad (7.63)$$

where

$$a_0 = \frac{\hbar^2}{\mu e^2} = 0.53 \times 10^{-10} \text{ m} , \quad (7.64)$$

is the Bohr's radius, and in terms of the dimensionless parameter

$$\lambda_{kl} = \sqrt{-\frac{E_{kl}}{E_I}} , \quad (7.65)$$

where

$$E_I = \frac{\mu e^4}{2\hbar^2} = 13.6 \text{ eV} , \quad (7.66)$$

is the ionization energy, the radial equation becomes

$$\left(-\frac{d^2}{d\rho^2} + V_l(\rho) + \lambda_{kl}^2 \right) u_{kl} = 0 \quad (7.67)$$

where

$$V_l(\rho) = -\frac{2}{\rho} + \frac{l(l+1)}{\rho^2} . \quad (7.68)$$

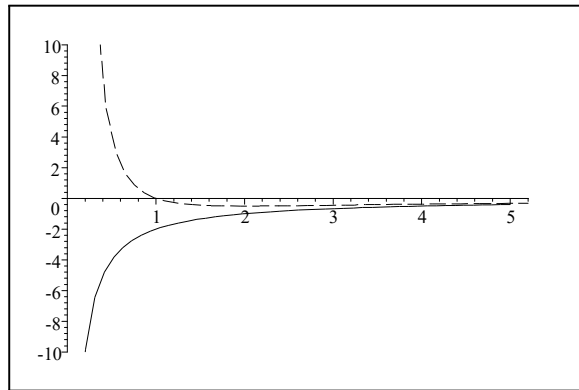

The function $V_l(\rho)$ for $l = 0$ (solid line) and $l = 1$ (dashed line).

We seek solutions of Eq. (7.67) that represent bound states, for which E_{kl} is negative, and thus λ_{kl} is a nonvanishing real positive. In the limit $\rho \rightarrow \infty$ the potential $V_l(\rho) \rightarrow 0$, and thus it becomes negligibly small in comparison with λ_{kl} [see Eq. (7.67)]. Therefore, in this limit the solution is expected to be asymptotically proportional to $e^{\pm\lambda_{kl}\rho}$. To ensure that the solution is normalizable the exponentially diverging solution $e^{+\lambda_{kl}\rho}$ is excluded. Moreover, as we have seen above, for small ρ the solution is expected to be proportional to ρ^{l+1} . Due to these considerations we express $u_{kl}(r)$ as

$$u_{kl}(r) = y(\rho) \rho^{l+1} e^{-\lambda_{kl}\rho} . \quad (7.69)$$

Substituting into Eq. (7.67) yields an equation for the function $y(\rho)$

$$\left[\frac{d^2}{d\rho^2} + 2 \left(\frac{l+1}{\rho} - \lambda_{kl} \right) \frac{d}{d\rho} + \frac{2(1 - \lambda_{kl}(l+1))}{\rho} \right] y = 0 . \quad (7.70)$$

Consider a power series expansion of the function $y(\rho)$

$$y(\rho) = \sum_{q=0}^{\infty} c_q \rho^q . \quad (7.71)$$

Substituting into Eq. (7.70) yields

$$\begin{aligned} & \sum_{q=0}^{\infty} q(q-1) c_q \rho^{q-2} + 2(l+1) \sum_{q=0}^{\infty} q c_q \rho^{q-2} \\ & - 2\lambda_{kl} \sum_{q=0}^{\infty} q c_q \rho^{q-1} + 2(1 - \lambda_{kl}(l+1)) \sum_{q=0}^{\infty} c_q \rho^{q-1} = 0 , \end{aligned} \quad (7.72)$$

thus

$$\frac{c_q}{c_{q-1}} = \frac{2[\lambda_{kl}(q+l) - 1]}{q(q+2l+1)} . \quad (7.73)$$

We argue below that for physically acceptable solutions $y(\rho)$ must be a polynomial function [i.e. the series (7.71) needs to be finite]. To see this note that for large q Eq. (7.73) implies that

$$\lim_{q \rightarrow \infty} \frac{c_q}{c_{q-1}} = \frac{2\lambda_{kl}}{q} . \quad (7.74)$$

Similar recursion relation holds for the coefficients of the power series expansion of the function $e^{2\lambda_{kl}\rho}$

$$e^{2\lambda_{kl}\rho} = \sum_{q=0}^{\infty} \tilde{c}_q \rho^q , \quad (7.75)$$

where

$$\tilde{c}_q = \frac{(2\lambda_{kl})^q}{q!}, \quad (7.76)$$

thus

$$\frac{\tilde{c}_q}{\tilde{c}_{q-1}} = \frac{2\lambda_{kl}}{q}. \quad (7.77)$$

This observation suggests that for large ρ the function u_{kl} asymptotically becomes proportional to $e^{\lambda_{kl}\rho}$. However, such an exponentially diverging solution must be excluded since it cannot be normalized. Therefore, to avoid such a discrepancy, we require that $y(\rho)$ must be a polynomial function. As can be seen from Eq. (7.73), this requirement is satisfied provided that $\lambda_{kl}(q+l) - 1 = 0$ for some q . A polynomial function of order $k-1$ is obtained when λ_{kl} is taken to be given by

$$\lambda_{kl} = \frac{1}{k+l}, \quad (7.78)$$

where $k = 1, 2, 3, \dots$. With the help of Eq. (7.73) the polynomial function can be evaluated. Some examples are given below

$$y_{k=1,l=0}(\rho) = c_0, \quad (7.79)$$

$$y_{k=1,l=1}(\rho) = c_0, \quad (7.80)$$

$$y_{k=2,l=0}(\rho) = c_0 \left(1 - \frac{\rho}{2}\right), \quad (7.81)$$

$$y_{k=2,l=1}(\rho) = c_0 \left(1 - \frac{\rho}{6}\right). \quad (7.82)$$

The coefficient c_0 can be determined from the normalization condition.

As can be seen from Eqs. (7.65) and (7.78), all states having the same sum $k+l$, which is denoted as

$$n = k + l, \quad (7.83)$$

have the same energy. The index n is called the principle quantum number. Due to this degeneracy, which is sometimes called accidental degeneracy, it is common to label the states with the indices n , l and m , instead of k , l and m . In such labeling the eigenenergies are given by

$$E_n = -\frac{E_1}{n^2}, \quad (7.84)$$

where

$$n = 1, 2, \dots \quad (7.85)$$

For a given n the quantum number l can take any of the possible values

$$l = 0, 1, 2, \dots, n-1, \quad (7.86)$$

and the quantum number m can take any of the possible values

$$m = -l, -l + 1, \dots, l - 1, l. \quad (7.87)$$

The level of degeneracy of the level E_n is given by

$$g_n = 2 \sum_{l=0}^{n-1} (2l + 1) = 2 \left(\frac{2(n-1)n}{2} + n \right) = 2n^2. \quad (7.88)$$

Note that the factor of 2 is due to spin. The normalized radial wave functions of the states with $n = 1$ and $n = 2$ are found to be given by

$$R_{10}(r) = 2 \left(\frac{1}{a_0} \right)^{3/2} e^{-\frac{r}{a_0}}, \quad (7.89)$$

$$R_{20}(r) = \left(2 - \frac{r}{a_0} \right) \left(\frac{1}{2a_0} \right)^{3/2} e^{-\frac{r}{2a_0}}, \quad (7.90)$$

$$R_{21}(r) = \left(\frac{1}{2a_0} \right)^{3/2} \frac{r}{\sqrt{3}a_0} e^{-\frac{r}{2a_0}}, \quad (7.91)$$

$$R_{30}(r) = 2 \left(\frac{1}{3a_0} \right)^{3/2} \left(1 - \frac{2r}{3a_0} + \frac{2r^2}{27a_0^2} \right) e^{-\frac{r}{3a_0}}, \quad (7.92)$$

$$R_{31}(r) = \frac{4\sqrt{2}}{3} \left(\frac{1}{3a_0} \right)^{3/2} \frac{r}{a_0} \left(1 - \frac{r}{6a_0} \right) e^{-\frac{r}{3a_0}}, \quad (7.93)$$

$$R_{32}(r) = \frac{2\sqrt{2}}{27\sqrt{5}} \left(\frac{1}{3a_0} \right)^{3/2} \left(\frac{r}{a_0} \right)^2 e^{-\frac{r}{3a_0}}, \quad (7.94)$$

The wavefunction $\varphi_{n,l,m}(\mathbf{r})$ of an eigenstate with quantum numbers n , l and m is given by

$$\varphi_{nlm}(r, \theta, \phi) = R_{nl}(r) Y_l^m(\theta, \phi). \quad (7.95)$$

The orthonormality relation reads

$$\langle n'l'm' | nlm \rangle = \int_0^\infty dr r^2 R_{n'l'} R_{nl} \int_{-1}^1 d(\cos \theta) \int_0^{2\pi} d\phi \left(Y_{l'}^{m'} \right)^* Y_l^m = \delta_{n,n'} \delta_{l,l'} \delta_{m,m'}. \quad (7.96)$$

While the index n labels the shell number, the index l labels the sub-shell. In spectroscopy it is common to label different sub-shells with letters:

- $l = 0$ s
- $l = 1$ p
- $l = 2$ d
- $l = 3$ f
- $l = 4$ g

7.4 Problems

1. Calculate the expectation value $\langle r^n \rangle$ for a hydrogen atom in its ground state, where r is the radial coordinate and n is integer.
2. Consider the wave function with quantum numbers n , l , and m of a hydrogen atom $\varphi_{n,l,m}(r)$.
 - a) Show that the probability current density in spherical coordinates r, θ, φ is given by

$$\mathbf{J}_{n,l,m}(r) = \frac{\hbar}{\mu} m \frac{|\varphi_{n,l,m}(\mathbf{r})|^2}{r \sin \theta} \hat{\phi}, \quad (7.97)$$

where μ is the reduced mass and $\hat{\phi}$ is a unit vector orthogonal to $\hat{\mathbf{z}}$ and $\hat{\mathbf{r}}$.

- b) Use the result of the previous section to show that the total angular momentum expectation value is given by $\langle \mathbf{L} \rangle = m\hbar\hat{\mathbf{z}}$.
3. Let $\mathbf{J}_{n,l,m}(\mathbf{r})$ be the probability current density corresponding to the wave function $\varphi_{n,l,m}(\mathbf{r})$ of a hydrogen atom energy eigenstate with quantum numbers n , l , and m . The field $\mathbf{B}_{n,l,m}$, which is defined by

$$\mathbf{B}_{n,l,m} = \frac{1}{c} \int d^3\mathbf{r}' \frac{\mathbf{r}' \times \mathbf{J}_{n,l,m}(\mathbf{r}')}{|\mathbf{r}'|^3}, \quad (7.98)$$

represents the classical magnetic field generated by the electron at the location of the nucleus. Calculate $\mathbf{B}_{n=1,l=0,m=0}$, $\mathbf{B}_{n=2,l=1,m=0}$ and $\mathbf{B}_{n=2,l=1,m=\pm 1}$.

4. Calculate the momentum wave function $\phi(p')$ of the hydrogen atom ground state.
5. Show that the average electrostatic potential in the neighborhood of a hydrogen atom in its ground state is given by

$$\varphi = e \left(\frac{1}{a_0} + \frac{1}{r} \right) \exp\left(-\frac{2r}{a_0}\right), \quad (7.99)$$

where a_0 is the Bohr radius.

6. A hydrogen atom is in its ground state. The distance r between the electron and the proton is measured. Calculate the expectation value $\langle r \rangle$ and the most probable value r_0 (at which the probability distribution function obtains a maximum).
7. Tritium, which is labeled as ${}^3\text{H}$, is a radioactive isotope of hydrogen. The nucleus of tritium contains 1 proton and two neutrons. An atom of tritium is in its ground state, when the nucleus suddenly decays into a helium nucleus, with the emission of a fast electron, which leaves the atom without perturbing the extra-nuclear electron. Find the probability that the resulting He^+ ion will be left in:

- a) 1s state.
 b) 2s state.
 c) a state with $l \neq 0$.
8. At time $t = 0$ a hydrogen atom is in the state

$$|\alpha(t=0)\rangle = A(|2, 1, -1\rangle + |2, 1, 1\rangle) ,$$

where A is a normalization constant and where $|n, l, m\rangle$ denotes the eigenstate with quantum numbers n, l and m . Calculate the expectation value $\langle x \rangle$ at time t .

9. Find the ground state energy E_0 of a particle having mass m in a central potential $V(r)$ given by

$$V(r) = \begin{cases} 0 & a \leq r \leq b \\ \infty & \text{else} \end{cases} , \quad (7.100)$$

where $r = \sqrt{x^2 + y^2 + z^2}$.

10. Consider a particle having mass m confined inside a spherical cavity of radius R , which is described by the central potential

$$V(r) = \begin{cases} 0 & r \leq R \\ \infty & r > R \end{cases} , \quad (7.101)$$

where $r = \sqrt{x^2 + y^2 + z^2}$. Calculate the ground state energy E_0 . Use the result to calculate the pressure P_0 exerted on the cavity wall by the particle in its ground state.

11. Consider a particle having mass m in a 3D potential given by

$$V(r) = -A\delta(r - a) , \quad (7.102)$$

where $r = \sqrt{x^2 + y^2 + z^2}$ is the radial coordinate, the length a is a constant and $\delta()$ is the delta function. For what range of values of the constant A the particle has a bound state.

12. Consider a particle having mass m in a 3D central potential given by

$$U(r) = \begin{cases} -U_0 & r \leq r_0 \\ 0 & r > r_0 \end{cases} . \quad (7.103)$$

where $r = \sqrt{x^2 + y^2 + z^2}$ is the radial coordinate, U_0 is real and r_0 is positive. For what range of values of the potential depth U_0 the particle has a bound state.

13. A spinless point particle is in state $|\gamma\rangle$. The state vector $|\gamma\rangle$ is an eigenvector of the operators L_x, L_y and L_z (the x, y and z components of the angular momentum vector operator). What can be said about the wavefunction $\psi(\mathbf{r}')$ of the state $|\gamma\rangle$?

14. Consider two (non-identical) particles having the same mass m moving under the influence of a potential $U(\mathbf{r})$, which is given by

$$U(\mathbf{r}) = \frac{1}{2}m\omega^2\mathbf{r}^2 . \quad (7.104)$$

In addition, the particles interact with each other via a potential given by

$$V(\mathbf{r}_1, \mathbf{r}_2) = \frac{1}{2}m\Omega^2(\mathbf{r}_1 - \mathbf{r}_2)^2 , \quad (7.105)$$

where \mathbf{r}_1 and \mathbf{r}_2 are the (three dimensional) coordinate vectors of the first and second particle respectively. Find the eigenenergies of the system.

15. Let \mathcal{H} be the Hamiltonian of the hydrogen atom.
- a) Calculate the energy expectation value $E(r_0) = \langle \alpha | \mathcal{H} | \alpha \rangle$ with respect to a state $|\alpha\rangle$, whose wavefunction (in radial coordinates) is given by

$$\langle \mathbf{r}' | \alpha \rangle = A e^{-\frac{1}{2}\left(\frac{r'}{r_0}\right)^2} , \quad (7.106)$$

where A is a normalization constant, and r_0 is a real constant.

- b) For what value of the parameter r_0 the energy $E(r_0)$ is minimized? What is the corresponding minimized value of $E(r_0)$?

16. The virial theorem

- a) The dynamics of a given system is governed by the Hamiltonian \mathcal{H} , which is assumed to be time independent. Let A be an observable that does not depend on time explicitly, and let $|e\rangle$ be a stationary state, i.e. an eigenvector of \mathcal{H} . Show that

$$\langle e | [A, \mathcal{H}] | e \rangle = 0 . \quad (7.107)$$

- b) Employ the relation (7.107) for the case of a point particle of mass m moving in three dimensions under the influence of the potential $V(\mathbf{r})$, and for the observable

$$A = \mathbf{r} \cdot \mathbf{p} + \mathbf{p} \cdot \mathbf{r} , \quad (7.108)$$

in order to show that

$$2 \langle e | \frac{\mathbf{p}^2}{2m} | e \rangle = \langle e | (\mathbf{r} \cdot \nabla V) | e \rangle . \quad (7.109)$$

17. A hydrogen atom is in its ground state. Calculate the expectation values $\langle T \rangle$ and $\langle U \rangle$ of the kinetic and potential energies, respectively.

18. A particle having mass m moves under the influence of a central potential $V(r')$ given by

$$V(r') = V_0 \log\left(\frac{r'}{r_0}\right), \quad (7.110)$$

where V_0 and r_0 are positive constants. Calculate the kinetic energy expectation values $\langle T_n \rangle$ of the bounded energy eigenstates of the system.

19. Consider a particle of mass m in a central potential $V(r)$. Let $|e\rangle$ be a bound stationary state (i.e. an eigenvector of the Hamiltonian) having wavefunction $\varphi(\mathbf{r})$. Show that

$$\frac{2\pi\hbar^2}{m} |\varphi(0)|^2 = \langle e | \frac{dV}{dr} | e \rangle - \frac{1}{m} \langle e | \frac{\mathbf{L}^2}{r^3} | e \rangle, \quad (7.111)$$

where \mathbf{L} is the angular momentum vector operator.

20. The radial equation for the hydrogen atom (7.61) represents the time independent Schrödinger equation for a point particle of mass μ moving in one dimension along the r axis whose Hamiltonian is given by

$$\mathcal{H}_l = \frac{p_r^2}{2\mu} + V_{\text{eff}}\left(\frac{r}{a_0}\right), \quad (7.112)$$

where the effective potential V_{eff} is given by

$$V_{\text{eff}}(\rho) = E_1 \left(-\frac{2}{\rho} + \frac{l(l+1)}{\rho^2} \right), \quad (7.113)$$

$a_0 = \hbar^2/\mu e^2$ is the Bohr's radius, $E_1 = \mu e^4/2\hbar^2$ is the ionization energy and l is a nonnegative integer. The operator a_l is defined by

$$a_l = \frac{a_0}{\sqrt{2}} \left(\frac{ip_r}{\hbar} - \frac{l+1}{r} + \frac{1}{(l+1)a_0} \right). \quad (7.114)$$

- a) Show that

$$\mathcal{H}_l = 2E_1 \left(a_l^\dagger a_l - \frac{1}{2(l+1)^2} \right). \quad (7.115)$$

- b) Show that the commutation relation $[a_l, a_l^\dagger]$ is given by

$$[a_l, a_l^\dagger] = \frac{\mathcal{H}_{l+1} - \mathcal{H}_l}{2E_1}. \quad (7.116)$$

- c) Given that $|E\rangle_l$ is an eigenvector of the Hamiltonian \mathcal{H}_l with an energy eigenvalue E , show that the state $a_l |E\rangle_l$ is an eigenvector of the Hamiltonian \mathcal{H}_{l+1} with the same energy eigenvalue E .

- d) Show that energy eigenvalues E of the Hamiltonian \mathcal{H}_l are bounded by

$$E \geq -\frac{E_l}{l(l+1)}. \quad (7.117)$$

- e) Use the above results to find all possible values of the energy eigenvalues E .

7.5 Solutions

1. The grounds state wavefunction is given by [see Eqs. (6.130) and (7.89)]

$$\psi = \frac{1}{\sqrt{4\pi}} 2 \left(\frac{1}{a_0} \right)^{3/2} e^{-\frac{r}{a_0}}, \quad (7.118)$$

thus

$$\begin{aligned} \langle r^n \rangle &= \frac{4}{a_0^3} \int_0^\infty dr r^{2+n} e^{-\frac{2r}{a_0}} \frac{1}{4\pi} \int_{-1}^1 d(\cos \theta) \int_0^{2\pi} d\phi \\ &= \frac{(n+2)! a_0^n}{2^{n+1}}. \end{aligned} \quad (7.119)$$

2. In general the current density is given by Eq. (4.274). For a wavefunction having the form

$$\psi(\mathbf{r}) = \alpha(\mathbf{r}) e^{i\beta(\mathbf{r})}, \quad (7.120)$$

where both α and β are real, one has

$$\begin{aligned} \mathbf{J} &= \frac{\hbar}{\mu} \text{Im} [\alpha(\nabla\alpha + i\alpha\nabla\beta)] \\ &= \frac{\hbar\alpha^2}{\mu} \nabla\beta \\ &= \frac{\hbar|\psi|^2}{\mu} \nabla\beta. \end{aligned} \quad (7.121)$$

- a) The wavefunction $\varphi_{n,l,m}(\mathbf{r})$ is given by

$$\psi_{nlm}(r, \theta, \phi) = R_{nl}(r) Y_l^m(\theta, \phi) = R_{nl}(r) F_l^m(\theta) e^{im\phi}, \quad (7.122)$$

where both R_{nl} and F_l^m are real, thus

$$\mathbf{J}_{n,l,m}(r) = \frac{\hbar |\varphi_{n,l,m}(\mathbf{r})|^2}{\mu} \nabla(m\phi) . \quad (7.123)$$

In spherical coordinates one has

$$\begin{aligned} \nabla &= \hat{\mathbf{x}} \frac{\partial}{\partial x} + \hat{\mathbf{y}} \frac{\partial}{\partial y} + \hat{\mathbf{z}} \frac{\partial}{\partial z} \\ &= \hat{\mathbf{r}} \frac{\partial}{\partial r} + \hat{\boldsymbol{\theta}} \frac{1}{r} \frac{\partial}{\partial \theta} + \hat{\boldsymbol{\phi}} \frac{1}{r \sin \theta} \frac{\partial}{\partial \phi} , \end{aligned} \quad (7.124)$$

thus Eq. (7.97) holds.

- b) The contribution of the volume element d^3r to the angular momentum with respect to the origin is given by $\mu \mathbf{r} \times \mathbf{J}_{n,l,m}(\mathbf{r}) d^3r$. In spherical coordinates the total angular momentum is given by

$$\langle \mathbf{L} \rangle = \int \mu \mathbf{r} \times \mathbf{J}_{n,l,m}(\mathbf{r}) d^3r = m\hbar \int \frac{|\varphi_{n,l,m}(\mathbf{r})|^2}{r \sin \theta} \mathbf{r} \times \hat{\boldsymbol{\phi}} d^3r . \quad (7.125)$$

By symmetry, only the component along $\hat{\mathbf{z}}$ of $\mathbf{r} \times \hat{\boldsymbol{\phi}}$ contributes, thus

$$\langle \mathbf{L} \rangle = m\hbar \hat{\mathbf{z}} . \quad (7.126)$$

3. With the help of Eq. (7.97) one finds that

$$\mathbf{B}_{n,l,m} = \frac{\hbar m}{\mu c} \int d^3\mathbf{r}' \frac{\mathbf{r}' \times \frac{|\varphi_{n,l,m}(\mathbf{r}')|^2}{r' \sin \theta'} \hat{\boldsymbol{\phi}}}{r'^3} , \quad (7.127)$$

where $\mathbf{r}'/r' = (\sin \theta' \cos \phi', \sin \theta' \sin \phi', \cos \theta')$, $\hat{\boldsymbol{\phi}} = (-\sin \phi', \cos \phi', 0)$ and $|\mathbf{r}'| = r'$, hence [see Eq. (7.95)]

$$\begin{aligned} \mathbf{B}_{n,l,m} &= \frac{\hbar m}{c\mu} \int_0^\infty dr' \frac{|R_{nl}(r')|^2}{r'} \int_{-1}^1 d(\cos \theta') \int_0^{2\pi} d\phi' \\ &\quad \times |Y_l^m(\theta', \phi')|^2 (-\cot \theta' \cos \phi', -\cot \theta' \sin \phi', 1) . \end{aligned} \quad (7.128)$$

Using the relations $\int_0^{2\pi} d\phi' \cos \phi' = \int_0^{2\pi} d\phi' \sin \phi' = 0$ one finds that $\mathbf{B}_{n=1,l=0,m=0} = 0$ and $\mathbf{B}_{n=2,l=1,m=0} = 0$ [see Eqs. (6.130) and (6.132)], and using the relations $\int_{-1}^1 d(\cos \theta') \sin^2 \theta' = 4/3$ and $\int_0^\infty d\rho \rho e^{-\rho} = 1$ one obtains [see Eqs. (6.131) and (7.91)]

$$\mathbf{B}_{n=2,l=1,m=\pm 1} = \pm \frac{\hbar}{24c\mu a_0^3} \hat{\mathbf{z}} . \quad (7.129)$$

4. The following holds [see Eqs. (3.60), (3.75) and (7.89)]

$$\phi(\mathbf{p}') = \int_0^\infty dr r^2 \int_{-1}^1 d(\cos \theta) \int_0^{2\pi} d\phi \frac{\exp\left(\frac{i\mathbf{p}' \cdot \mathbf{r}}{\hbar}\right) R_{10}(r)}{(2\pi\hbar)^{3/2}} , \quad (7.130)$$

where the integration is performed using a spherical coordinate system having a z axis parallel to the momentum vector \mathbf{p}' , hence $i\mathbf{p}' \cdot \mathbf{r} = ip'r \cos \theta$, and thus

$$\begin{aligned} \phi(\mathbf{p}') &= 2\pi \int_0^\infty dr r^2 \frac{R_{10}(r)}{(2\pi\hbar)^{3/2}} \int_{-1}^1 d(\cos \theta) \exp\left(\frac{ip'r \cos \theta}{\hbar}\right) \\ &= \frac{8(2\pi)^{-1/2} \left(\frac{a_0}{\hbar}\right)^{3/2}}{\left(1 + \left(\frac{p'a_0}{\hbar}\right)^2\right)^2}. \end{aligned} \quad (7.131)$$

5. The charge density of the electron in the ground state is given by

$$\rho = -e |\varphi_{1,0,0}(\mathbf{r})|^2 = -\frac{e}{\pi a_0^3} \exp\left(-\frac{2r}{a_0}\right). \quad (7.132)$$

The Poisson's equation is given by

$$\nabla^2 \varphi = -4\pi\rho. \quad (7.133)$$

To verify that the electrostatic potential given by Eq. (7.99) solves this equation we calculate

$$\begin{aligned} \nabla^2 \varphi &= \frac{1}{r} \frac{d^2}{dr^2} (r\varphi) \\ &= \frac{e}{r} \frac{d^2}{dr^2} \left[\left(\frac{r}{a_0} + 1 \right) \exp\left(-\frac{2r}{a_0}\right) \right] \\ &= \frac{4e \exp\left(-\frac{2r}{a_0}\right)}{a_0^3} \\ &= -4\pi\rho. \end{aligned} \quad (7.134)$$

Note also that

$$\lim_{r \rightarrow \infty} \varphi(r) = 0, \quad (7.135)$$

as is required for a neutral atom.

6. The radial wave function of the ground state is given by

$$R_{10}(r) = 2 \left(\frac{1}{a_0} \right)^{3/2} \exp\left(-\frac{r}{a_0}\right) \quad (7.136)$$

thus the probability distribution function of the variable r is given by

$$f(r) = |rR_{10}(r)|^2 = \frac{4}{r} \left(\frac{r}{a_0} \right)^3 \exp\left(-\frac{2r}{a_0}\right). \quad (7.137)$$

Thus

$$\langle r \rangle = \int_0^\infty r f(r) dr = 4a_0 \int_0^\infty x^3 \exp(-2x) dx = \frac{3}{2}a_0. \quad (7.138)$$

The most probable value r_0 is found from the condition

$$0 = \frac{df}{dr} = \frac{8r_0}{a_0^4} \exp\left(-\frac{2r_0}{a_0}\right) (a_0 - r_0), \quad (7.139)$$

thus

$$r_0 = a_0. \quad (7.140)$$

7. The radial wave function of a hydrogen-like atom with a nucleus having charge Ze is found by substituting e^2 by Ze^2 in Eqs. (7.89), (7.90) and (7.91), namely

$$R_{10}^{(Z)}(r) = 2 \left(\frac{Z}{a_0}\right)^{3/2} e^{-Zr/a_0}, \quad (7.141)$$

$$R_{20}^{(Z)}(r) = (2 - Zr/a_0) \left(\frac{Z}{2a_0}\right)^{3/2} e^{-\frac{Zr}{2a_0}}, \quad (7.142)$$

$$R_{21}^{(Z)}(r) = \left(\frac{Z}{2a_0}\right)^{3/2} \frac{Zr}{\sqrt{3}a_0} e^{-\frac{Zr}{2a_0}}. \quad (7.143)$$

The change in reduced mass is neglected. Therefore

- a) For the 1s state

$$\text{Pr}(1s) = \left(\int_0^\infty dr r^2 R_{10}^{(Z=1)} R_{10}^{(Z=2)} \right)^2 = \frac{2^7}{a_0^3} \frac{(2a_0^3)^2}{3^3} = 0.702.$$

- b) For the 2s state

$$\text{Pr}(2s) = \left(\int_0^\infty dr r^2 R_{10}^{(Z=1)} R_{20}^{(Z=2)} \right)^2 = \frac{16}{a_0^6} \left(\frac{a_0^3}{8} (2-3) \right)^2 = 0.25.$$

- c) For this case the probability vanishes due to the orthogonality between spherical harmonics with different l .

8. The normalization constant is chosen to be $A = 1/\sqrt{2}$. Since both states $|2, 1, -1\rangle$ and $|2, 1, 1\rangle$ have the same energy the state $|\alpha\rangle$ is stationary. The following holds

$$\psi_{nlm}(r, \theta, \phi) = R_{nl}(r) Y_l^m(\theta, \phi) , \quad (7.144a)$$

$$R_{21}(r) = \left(\frac{1}{2a_0}\right)^{3/2} \frac{r}{\sqrt{3}a_0} e^{-\frac{r}{2a_0}} , \quad (7.144b)$$

$$Y_1^{-1}(\theta, \phi) = \frac{1}{2} \sqrt{\frac{3}{2\pi}} \sin \theta e^{-i\phi} , \quad (7.144c)$$

$$Y_1^1(\theta, \phi) = -\frac{1}{2} \sqrt{\frac{3}{2\pi}} \sin \theta e^{i\phi} , \quad (7.144d)$$

$$x = r \sin \theta \cos \phi . \quad (7.144e)$$

In general

$$\langle n'l'm' | x | nlm \rangle = \int_0^\infty dr r^3 R_{n'l'} R_{nl} \int_{-1}^1 d(\cos \theta) \int_0^{2\pi} d\phi \sin \theta \cos \phi \left(Y_l^{m'}\right)^* Y_l^m . \quad (7.145)$$

thus

$$\langle 2, 1, 1 | x | 2, 1, 1 \rangle \propto \int_0^{2\pi} d\phi \cos \phi = 0 , \quad (7.146)$$

$$\langle 2, 1, -1 | x | 2, 1, -1 \rangle \propto \int_0^{2\pi} d\phi \cos \phi = 0 , \quad (7.147)$$

$$\langle 2, 1, 1 | x | 2, 1, -1 \rangle \propto \int_0^{2\pi} d\phi \cos \phi e^{-2i\phi} = 0 , \quad (7.148)$$

$$\langle 2, 1, -1 | x | 2, 1, 1 \rangle \propto \int_0^{2\pi} d\phi \cos \phi e^{2i\phi} = 0 , \quad (7.149)$$

and therefore

$$\langle x \rangle (t) = 0 . \quad (7.150)$$

9. The radial equation is given by [see Eq. (7.36)]

$$\left[-\frac{\hbar^2}{2m} \frac{d^2}{dr^2} + \frac{l(l+1)\hbar^2}{2mr^2} + V(r) \right] u_{k,l}(r) = E_{k,l} u_{k,l}(r) . \quad (7.151)$$

Since the centrifugal term $l(l+1)\hbar^2/2mr^2$ is non-negative the ground state is obtained with $l = 0$. Thus the ground state energy is [see Eq. (4.255)]

$$E_0 = \frac{\pi^2 \hbar^2}{2m(b-a)^2} . \quad (7.152)$$

10. The ground state energy is given by Eq. (7.152)

$$E_0 = \frac{\pi^2 \hbar^2}{2mR^2}, \quad (7.153)$$

and thus the pressure P is given by (recall that surface area of the sphere is $4\pi R^2$)

$$P = -\frac{1}{4\pi R^2} \frac{dE_0}{dR} = \frac{\pi \hbar^2}{4mR^5}. \quad (7.154)$$

11. The radial equation is given by

$$\left[-\frac{\hbar^2}{2m} \frac{d^2}{dr^2} + \frac{l(l+1)\hbar^2}{2mr^2} + V(r) \right] u_{k,l}(r) = E_{k,l} u_{k,l}(r). \quad (7.155)$$

The boundary conditions imposed upon $u(r)$ by the potential are

$$u(0) = 0, \quad (7.156)$$

$$u(a^+) = u(a^-) \quad (7.157)$$

$$\frac{du(a^+)}{dr} - \frac{du(a^-)}{dr} = -\frac{2}{a_0} u(a). \quad (7.158)$$

where

$$a_0 = \frac{\hbar^2}{mA}. \quad (7.159)$$

Since the centrifugal term $l(l+1)\hbar^2/2mr^2$ is non-negative the ground state is obtained with $l=0$. We seek a solution for that case having the form

$$u(r) = \begin{cases} \sinh(\kappa r) & r < a \\ \sinh(\kappa a) \exp(-\kappa(r-a)) & r > a \end{cases}, \quad (7.160)$$

where

$$\kappa = \frac{\sqrt{-2mE}}{\hbar}. \quad (7.161)$$

The condition (7.158) yields

$$-\kappa \sinh(\kappa a) - \kappa \cosh(\kappa a) = -\frac{2}{a_0} \sinh(\kappa a), \quad (7.162)$$

or

$$\frac{\kappa a_0}{2} = \frac{1}{1 + \coth(\kappa a)}.$$

A real solution exists only if

$$\frac{a_0}{2} < a, \quad (7.163)$$

or

$$A > \frac{\hbar^2}{2ma}. \quad (7.164)$$

12. The radial equation is given by

$$\left[-\frac{\hbar^2}{2m} \frac{d^2}{dr^2} + \frac{l(l+1)\hbar^2}{2mr^2} + U(r) \right] u_{k,l}(r) = E_{k,l} u_{k,l}(r). \quad (7.165)$$

The boundary condition that is imposed upon $u(r)$ at the origin is $u(0) = 0$. Since the centrifugal term $l(l+1)\hbar^2/2mr^2$ is non-negative the ground state is obtained with $l = 0$. For that case the solution in the range $r \leq r_0$ has the form $u(r) = \sin kr$, where k is related to the energy E by

$$\frac{\hbar^2 k^2}{2m} = E + U_0. \quad (7.166)$$

In the range $r > r_0$ the general solution has the form $u(r) = Ae^{-\kappa r} + Be^{\kappa r}$, where

$$\frac{\hbar^2 \kappa^2}{2m} = -E. \quad (7.167)$$

A bound state can be obtained provided that $E < 0$ (to ensure that κ is real) and $B = 0$ (to ensure that $\lim_{r \rightarrow \infty} u(r) = 0$; it is assumed that κ is non-negative). The requirements that both $u(r)$ and du/dr [see Eq. (4.173)] are continuous at $r = r_0$ yield (for the case $B = 0$)

$$\sin kr_0 = Ae^{-\kappa r_0}, \quad (7.168)$$

$$\frac{k}{\kappa} \cos kr_0 = -Ae^{-\kappa r_0}, \quad (7.169)$$

thus the following must hold

$$\tan kr_0 = -\frac{k}{\kappa}. \quad (7.170)$$

Since both k and κ are required to be nonnegative, the above condition can be satisfied only if $\tan kr_0 \leq 0$, which implies that

$$kr_0 = \sqrt{\frac{2m(E + U_0)}{\hbar^2}} r_0 \geq \frac{\pi}{2}. \quad (7.171)$$

This together with the requirement that $E < 0$ yield

$$\sqrt{\frac{2mU_0}{\hbar^2}} r_0 \geq \frac{\pi}{2}, \quad (7.172)$$

or

$$U_0 \geq \frac{\pi^2 \hbar^2}{8mr_0^2}. \quad (7.173)$$

13. The state vector $|\gamma\rangle$ is an eigenvector of the operators L_x, L_y , therefore it is easy to see that it consequently must be an eigenvector of the operator $[L_x, L_y]$ with a zero eigenvalue. Thus, since $[L_x, L_y] = i\hbar L_z$, one has $L_z |\gamma\rangle = 0$. Similarly, one finds that $L_x |\gamma\rangle = L_y |\gamma\rangle = 0$. Therefore, $|\gamma\rangle$ is also an eigenvector of the operator $\mathbf{L}^2 = L_x^2 + L_y^2 + L_z^2$ with a zero eigenvalue. Therefore the wavefunction has the form

$$\psi(\mathbf{r}') = R(r') Y_{l=0}^{m=0}(\theta', \phi') = \frac{R(r')}{\sqrt{4\pi}}, \quad (7.174)$$

where the radial function $R(r')$ is an arbitrary normalized function.

14. The Lagrangian is given by

$$\mathcal{L} = \frac{m(\dot{\mathbf{r}}_1^2 + \dot{\mathbf{r}}_2^2)}{2} - \frac{1}{2}m\omega^2(\mathbf{r}_1^2 + \mathbf{r}_2^2) - \frac{1}{2}m\Omega^2(\mathbf{r}_1 - \mathbf{r}_2)^2. \quad (7.175)$$

In terms of center of mass \mathbf{r}_0 and relative \mathbf{r} coordinates, which are given by

$$\mathbf{r}_0 = \frac{\mathbf{r}_1 + \mathbf{r}_2}{2}, \quad (7.176)$$

$$\mathbf{r} = \mathbf{r}_1 - \mathbf{r}_2, \quad (7.177)$$

the Lagrangian is given by

$$\begin{aligned} \mathcal{L} &= \frac{m \left[(\dot{\mathbf{r}}_0 + \frac{1}{2}\dot{\mathbf{r}})^2 + (\dot{\mathbf{r}}_0 - \frac{1}{2}\dot{\mathbf{r}})^2 \right]}{2} \\ &\quad - \frac{1}{2}m\omega^2 \left[\left(\mathbf{r}_0 + \frac{1}{2}\mathbf{r} \right)^2 + \left(\mathbf{r}_0 - \frac{1}{2}\mathbf{r} \right)^2 \right] - \frac{1}{2}m\Omega^2\mathbf{r}^2 \\ &= \frac{m(2\dot{\mathbf{r}}_0^2 + \frac{1}{2}\dot{\mathbf{r}}^2)}{2} - \frac{1}{2}m\omega^2 \left(2\mathbf{r}_0^2 + \frac{1}{2}\mathbf{r}^2 \right) - \frac{1}{2}m\Omega^2\mathbf{r}^2 \\ &= \frac{M\dot{\mathbf{r}}_0^2}{2} - \frac{1}{2}M\omega^2\mathbf{r}_0^2 + \frac{\mu\dot{\mathbf{r}}^2}{2} - \frac{1}{2}\mu(\omega^2 + 2\Omega^2)\mathbf{r}^2, \end{aligned} \quad (7.178)$$

where the total mass M is given by

$$M = 2m, \quad (7.179)$$

and the reduced mass [see also Eq. (7.50)] by

$$\mu = \frac{m}{2}. \quad (7.180)$$

The Lagrangian \mathcal{L} describes two decoupled three dimensional harmonic oscillators. The first, which is associated with the center of mass motion, has mass $M = 2m$ and angular resonance frequency ω , whereas the

second one, which is associated with the relative coordinate \mathbf{r} , has mass $\mu = m/2$ and angular resonance frequency $\sqrt{\omega^2 + 2\Omega^2}$. The quantum energy eigenvectors are denoted by $|n_{0x}, n_{0y}, n_{0z}, n_x, n_y, n_z\rangle$, where all six quantum numbers $n_{0x}, n_{0y}, n_{0z}, n_x, n_y$ and n_z are integers, and the corresponding eigenenergies are given by

$$E_{n_{0x}, n_{0y}, n_{0z}, n_x, n_y, n_z} = \hbar\omega \left(\frac{3}{2} + n_{0x} + n_{0y} + n_{0z} \right) + \hbar\sqrt{\omega^2 + 2\Omega^2} \left(\frac{3}{2} + n_x + n_y + n_z \right). \quad (7.181)$$

15. The normalization condition reads (the coordinate transformation $r' = r_0\rho$ is being employed)

$$\begin{aligned} 1 &= \langle \alpha | \alpha \rangle \\ &= |A|^2 \int_0^\infty dr' r'^2 e^{-\left(\frac{r'}{r_0}\right)^2} \underbrace{\int_0^\pi d\theta \sin\theta \int_0^{2\pi} d\phi}_{4\pi} \\ &= 4\pi |A|^2 r_0^3 \int_0^\infty d\rho \rho^2 e^{-\rho^2} \\ &= \pi^{3/2} |A|^2 r_0^3. \end{aligned} \quad (7.182)$$

- a) The energy expectation value $E(r_0)$ is calculated with the help of Eq. (7.30). For a state whose wavefunction is independent on both θ' and ϕ' the angular momentum term $\langle \mathbf{r}' | \mathbf{L}^2 | \alpha \rangle$ vanishes, and thus

$$\begin{aligned} E(r_0) &= 4\pi |A|^2 r_0^3 \int_0^\infty d\rho \left[-\frac{\hbar^2}{2\mu r_0^2} \rho e^{-\frac{\rho^2}{2}} \frac{d^2}{d\rho^2} \left(\rho e^{-\frac{\rho^2}{2}} \right) - \frac{e^2 \rho e^{-\rho^2}}{r_0} \right] \\ &= \frac{3\hbar^2}{4\mu r_0^2} - \frac{2e^2}{\pi^{1/2} r_0} \\ &= f(s) E_I, \end{aligned} \quad (7.183)$$

where μ is the reduced mass, $E_I = \mu e^4 / 2\hbar^2$ is the ionization energy, the function $f(s)$ is given by

$$f(s) = \frac{3}{2s^2} - \frac{4}{\sqrt{\pi}s}, \quad (7.184)$$

the dimensionless variable s is given by

$$s = \frac{r_0}{a_0}, \quad (7.185)$$

and $a_0 = \hbar^2/\mu e^2$ is the Bohr's radius.

- b) At the point $s = 3\sqrt{\pi}/4$, at which the function $f(s)$ obtains its minimum value, one has

$$E(r_0) = -\frac{8}{3\pi}E_1. \quad (7.186)$$

16. Let E be the energy eigenvalue corresponding to the eigenvector $|e\rangle$, i.e. $\mathcal{H}|e\rangle = E|e\rangle$.

- a) Since E is real one has

$$\langle e|[A, \mathcal{H}]|e\rangle = E(\langle e|A|e\rangle - \langle e|A|e\rangle) = 0. \quad (7.187)$$

- b) The Hamiltonian is given by

$$\mathcal{H} = \frac{\mathbf{p}^2}{2m} + V(\mathbf{r}), \quad (7.188)$$

and thus the relation (7.107) yields

$$\langle e|\left[\mathbf{r} \cdot \mathbf{p} + \mathbf{p} \cdot \mathbf{r}, \frac{\mathbf{p}^2}{2m}\right]|e\rangle = -\langle e|[\mathbf{r} \cdot \mathbf{p} + \mathbf{p} \cdot \mathbf{r}, V]|e\rangle. \quad (7.189)$$

The following holds [see Eq. (3.29)]

$$\langle e|[\mathbf{r} \cdot \mathbf{p} + \mathbf{p} \cdot \mathbf{r}, V(r)]|e\rangle = -2i\hbar\langle e|\mathbf{r} \cdot \nabla V|e\rangle. \quad (7.190)$$

Using $[x_i, p_j] = i\hbar\delta_{ij}$ one obtains

$$2\langle e|\frac{\mathbf{p}^2}{2m}|e\rangle = \langle e|\mathbf{r} \cdot \nabla V|e\rangle. \quad (7.191)$$

17. The following holds

$$\langle U \rangle = \int_0^\infty dr r^2 V(r) R_{10}^2(r), \quad (7.192)$$

where $R_{10}(r) = 2a_0^{-3/2}e^{-r/a_0}$ [see Eq. (7.89)], a_0 is the Bohr's radius, and $V(r) = -e^2/r$, hence

$$\langle U \rangle = -\frac{4e^2}{a_0} \int_0^\infty d\rho \rho e^{-2\rho} = -\frac{e^2}{a_0}, \quad (7.193)$$

and thus [see Eq. (7.109)]

$$\langle T \rangle = \frac{\langle \mathbf{r} \cdot \nabla V \rangle}{2} = -\frac{\langle U \rangle}{2} = \frac{e^2}{2a_0}. \quad (7.194)$$

Note that $\langle U \rangle + \langle T \rangle = -e^2/(2a_0)$ [compare with Eq. (7.84)].

18. Let $|\psi_n\rangle$ be a bounded energy eigenstate. With the help of the virial theorem (7.109) one finds that the corresponding kinetic energy expectation values $\langle T_n \rangle$ is given by

$$\begin{aligned}\langle T_n \rangle &= \langle \psi_n | \frac{\mathbf{p}^2}{2m} | \psi_n \rangle \\ &= \frac{1}{2} \langle \psi_n | (\mathbf{r} \cdot \nabla V) | \psi_n \rangle ,\end{aligned}\tag{7.195}$$

and thus [see Eq. (7.110)]

$$\begin{aligned}\langle T_n \rangle &= \frac{V_0}{2} \langle \psi_n | r' \frac{\partial}{\partial r'} \log \left(\frac{r'}{r_0} \right) | \psi_n \rangle \\ &= \frac{V_0}{2} \langle \psi_n | \psi_n \rangle \\ &= \frac{V_0}{2} .\end{aligned}\tag{7.196}$$

19. The wavefunction $\varphi(\mathbf{r})$ can be expressed as [see Eq. (7.31)]

$$\varphi(\mathbf{r}) = R(r) Y_l^m(\theta, \phi) ,\tag{7.197}$$

where the function $u(r)$, which is related to $R(r)$ by [see Eq. (7.35)]

$$R(r) = \frac{u(r)}{r} ,\tag{7.198}$$

satisfies the radial equation (7.36)

$$\left(-\frac{\hbar^2}{2m} \frac{d^2}{dr^2} + \frac{l(l+1)\hbar^2}{2mr^2} + V \right) u = Eu ,\tag{7.199}$$

where E is the energy eigenvalue. The function $u(r)$ can be chosen to be real. Multiplying by $u' = du/dr$ yields (note that $uu' = (u^2)'/2$ and $u'u'' = ((u')^2)'/2$)

$$-\frac{\hbar^2}{2m} \left((u')^2 \right)' = \left(E - \frac{l(l+1)\hbar^2}{2mr^2} - V \right) (u^2)' .\tag{7.200}$$

Integration from 0 to ∞ leads to

$$-\frac{\hbar^2}{2m} \int_0^\infty dr \left((u')^2 \right)' = \int_0^\infty dr \left(E - \frac{l(l+1)\hbar^2}{2mr^2} - V \right) (u^2)' .\tag{7.201}$$

Employing integration by parts together with the boundary conditions $\lim_{r \rightarrow 0} u = \lim_{r \rightarrow \infty} u = 0$ yield (recall that u is assumed to be real)

$$\begin{aligned}
& \int_0^\infty dr \left(E - \frac{l(l+1)\hbar^2}{2mr^2} - V \right) (u^2)' \\
&= \int_0^\infty dr \left(-\frac{l(l+1)\hbar^2}{mr^3} + V' \right) u^2 .
\end{aligned} \tag{7.202}$$

The following holds [recall Eq. (7.45)]

$$\lim_{r \rightarrow 0} u'(r) = \lim_{r \rightarrow 0} (R(r) + rR'(r)) = R(0) , \tag{7.203}$$

thus

$$\int_0^\infty dr \left((u')^2 \right)' = -(R(0))^2 , \tag{7.204}$$

and therefore

$$\frac{\hbar^2}{2m} (R(0))^2 = \int_0^\infty dr \left(-\frac{l(l+1)\hbar^2}{mr^3} + V' \right) u^2 . \tag{7.205}$$

Multiplying by $|Y_l^m(\theta, \phi)|^2$ and integrating over the angles θ and ϕ leads to Eq. (7.111) [see Eq. (6.114)].

20. The following holds

$$a_l^\dagger a_l = \frac{a_0^2}{2} \left(\frac{p_r^2}{\hbar^2} + \frac{i}{\hbar} \left[p_r, \frac{l+1}{r} \right] + \left(\frac{l+1}{r} - \frac{1}{(l+1)a_0} \right)^2 \right) , \tag{7.206}$$

$$a_l a_l^\dagger = \frac{a_0^2}{2} \left(\frac{p_r^2}{\hbar^2} - \frac{i}{\hbar} \left[p_r, \frac{l+1}{r} \right] + \left(\frac{l+1}{r} - \frac{1}{(l+1)a_0} \right)^2 \right) . \tag{7.207}$$

a) Using Eq. (3.76) one finds that

$$\left[p_r, \frac{l+1}{r} \right] = i\hbar \frac{l+1}{r^2} , \tag{7.208}$$

and thus with the help of Eq. (7.206) one finds that

$$2E_l \left(a_l^\dagger a_l - \frac{1}{2(l+1)^2} \right) = 2E_l \left(\frac{a_0^2 p_r^2}{2\hbar^2} + \frac{a_0^2 l(l+1)}{2r^2} - \frac{a_0}{r} \right) = \mathcal{H}_l . \tag{7.209}$$

b) Using Eqs. (7.206), (7.207) and (7.208) one obtains

$$\left[a_l, a_l^\dagger \right] = a_0^2 \frac{l+1}{r^2} = \frac{\mathcal{H}_{l+1} - \mathcal{H}_l}{2E_l} . \tag{7.210}$$

- c) Since $|E\rangle_l$ is an eigenvector of \mathcal{H}_l with an energy eigenvalue E , the following holds

$$\mathcal{H}_l |E\rangle_l = E |E\rangle_l . \quad (7.211)$$

With the help of Eqs. (7.115) and (7.116) one finds that

$$\begin{aligned} \mathcal{H}_{l+1} a_l |E\rangle_l &= (\mathcal{H}_{l+1} - \mathcal{H}_l) a_l |E\rangle_l + \mathcal{H}_l a_l |E\rangle_l \\ &= 2E_l \left[a_l, a_l^\dagger \right] a_l |E\rangle_l + ([\mathcal{H}_l, a_l] + a_l \mathcal{H}_l) |E\rangle_l \\ &= \left[2E_l \left(\left[a_l, a_l^\dagger \right] a_l + \left[a_l^\dagger a_l, a_l \right] \right) + E a_l \right] |E\rangle_l \\ &= \left[2E_l \left(\left[a_l, a_l^\dagger \right] a_l + \left[a_l^\dagger, a_l \right] a_l \right) + E a_l \right] |E\rangle_l \\ &= E a_l |E\rangle_l , \end{aligned} \quad (7.212)$$

thus the state $a_l |E\rangle_l$ is an eigenvector of \mathcal{H}_{l+1} with energy eigenvalue E . A normalized eigenvector of \mathcal{H}_{l+1} with energy eigenvalue E , which is denoted by $|E\rangle_{l+1}$, is obtained by dividing by the norm of $a_l |E\rangle_l$ (note that $|E\rangle_l$ is assumed to be normalized)

$$|E\rangle_{l+1} = \frac{a_l |E\rangle_l}{\sqrt{l \langle E | a_l^\dagger a_l | E \rangle_l}} , \quad (7.213)$$

and thus [see Eq. (7.115)]

$$|E\rangle_{l+1} = \left(\frac{E}{2E_l} + \frac{1}{2(l+1)^2} \right)^{-1/2} a_l |E\rangle_l . \quad (7.214)$$

- d) Since the kinetic energy operator is positive-definite, the following holds

$$\langle \mathcal{H}_l \rangle \geq \langle V_{\text{eff}} \rangle . \quad (7.215)$$

On the other hand, with the help of Eq. (7.113) it is easy to show that

$$V_{\text{eff}}(\rho) \geq -\frac{E_l}{l(l+1)} , \quad (7.216)$$

and thus (7.117) holds.

- e) As was shown above, the operator a_l transforms an eigenvector having angular momentum quantum number l to another eigenvector having angular momentum quantum number $l+1$ and the same energy E . On the other hand the energy E is bounded by (7.117). Thus for any negative value of E there must be a maximum value of l , which is labeled as l_{max} , for which the corresponding state $|E\rangle_{l_{\text{max}}}$ is

transformed by the operator a_l to the zero vector, i.e. $a_l |E\rangle_{l_{\max}} = 0$, or alternatively ${}_{l_{\max}}\langle E| a_l^\dagger a_l |E\rangle_{l_{\max}} = 0$, thus

$${}_{l_{\max}}\langle E| a_l^\dagger a_l |E\rangle_{l_{\max}} = \frac{E}{2E_1} + \frac{1}{2(l_{\max} + 1)^2} = 0, \quad (7.217)$$

and therefore

$$E = -\frac{E_1}{n^2}, \quad (7.218)$$

where $n = l_{\max} + 1$ is a positive integer (recall that the quantum number l is a nonnegative integer).

8. Density Operator

Consider a measurement of an observable A , having a set of eigenvalues $\{a_n\}$ and corresponding set of eigenvectors $\{|a_n\rangle\}$

$$A |a_n\rangle = a_n |a_n\rangle . \quad (8.1)$$

The set of eigenvectors $\{|a_n\rangle\}$ is assumed to be orthonormal and complete

$$\langle a_n | a_m \rangle = \delta_{nm} , \quad (8.2)$$

$$\sum_n |a_n\rangle \langle a_n| = 1 . \quad (8.3)$$

Consider first the case where the state $|\alpha\rangle$ of the system under measurement is known.

Claim. The expectation value $\langle A \rangle = \langle \alpha | A | \alpha \rangle$ can be expressed as

$$\langle A \rangle = \text{Tr} (\rho_\alpha A) , \quad (8.4)$$

where the operator ρ_α is given by

$$\rho_\alpha = |\alpha\rangle \langle \alpha| . \quad (8.5)$$

Proof. With the help of Eq. (8.3) one obtains

$$\begin{aligned} \langle A \rangle &= \langle \alpha | A | \alpha \rangle \\ &= \langle \alpha | A \left(\sum_n |a_n\rangle \langle a_n| \right) | \alpha \rangle \\ &= \sum_n \langle a_n | \alpha \rangle \langle \alpha | A | a_n \rangle \\ &= \sum_n \langle a_n | \rho_\alpha A | a_n \rangle , \end{aligned} \quad (8.6)$$

thus Eq. (8.4) holds [see Eq. (2.132)].

The relation (8.4) can be generalized for cases where the state vector $|\alpha\rangle$ is not known in advance. Consider an ensemble of N identical copies

of a quantum system. The ensemble can be divided into subsets, where all systems belonging to the same subset have the same state vector. Let Nw_i be the number of systems having state vector $|\alpha^{(i)}\rangle$, where

$$0 \leq w_i \leq 1, \quad (8.7)$$

and where

$$\sum_i w_i = 1. \quad (8.8)$$

The state vectors $|\alpha^{(i)}\rangle$ are all assumed to be normalized

$$\langle \alpha^{(i)} | \alpha^{(i)} \rangle = 1. \quad (8.9)$$

Claim. The expectation value $\langle A \rangle$ (i.e. the averaged measured value) can be expressed as

$$\langle A \rangle = \text{Tr}(\rho A), \quad (8.10)$$

where the so-called density operator ρ is given by

$$\rho = \sum_i w_i |\alpha^{(i)}\rangle \langle \alpha^{(i)}|. \quad (8.11)$$

Proof. The expectation value $\langle A \rangle$ given that the state vector of the system is $|\alpha^{(i)}\rangle$ is given by $\text{Tr}(\rho_{\alpha^{(i)}} A)$, where $\rho_{\alpha^{(i)}} = |\alpha^{(i)}\rangle \langle \alpha^{(i)}|$ [see Eq. (8.4)]. The probability that the state of the measured system is $|\alpha^{(i)}\rangle$ is w_i , and thus on average $\langle A \rangle = \sum_i w_i \text{Tr}(\rho_{\alpha^{(i)}} A)$, hence Eq. (8.10) holds.

Claim. The following holds

$$\text{Tr}(\rho) = 1. \quad (8.12)$$

Proof. Using the definition (8.11) one obtains [see Eq. (8.9)]

$$\text{Tr}(\rho) = \sum_i w_i \text{Tr}(|\alpha^{(i)}\rangle \langle \alpha^{(i)}|) = \sum_i w_i, \quad (8.13)$$

thus Eq. (8.12) holds [see Eq. (8.8)].

As can be seen from the definition (8.11), the density operator is Hermitian, i.e.

$$\rho^\dagger = \rho. \quad (8.14)$$

This guaranties the existence of a complete orthonormal basis $\{|q_m\rangle\}$ of eigenvectors of ρ , which satisfies

$$\langle q_{m'} | q_m \rangle = \delta_{mm'} , \quad (8.15)$$

$$\sum_m |q_m\rangle \langle q_m| = 1 , \quad (8.16)$$

and

$$\rho |q_m\rangle = q_m |q_m\rangle , \quad (8.17)$$

where the eigenvalues q_m are real.

8.1 Pure and mixed states

Definition 8.1.1. *An ensemble is said to be pure if its density operator can be expressed as*

$$\rho = |\alpha\rangle \langle \alpha| . \quad (8.18)$$

Claim. In general $\text{Tr}(\rho^2) \leq 1$. Equality holds, i.e. $\text{Tr}(\rho^2) = 1$ iff ρ represents a pure ensemble.

Proof. The following holds [see Eqs. (8.11) and (8.17)]

$$q_m = \langle q_m | \rho | q_m \rangle = \sum_i w_i \left| \langle q_m | \alpha^{(i)} \rangle \right|^2 , \quad (8.19)$$

hence [see the Schwartz inequality (2.172) and Eqs. (8.7), (8.9) and (8.15)]

$$0 \leq q_m \leq 1 . \quad (8.20)$$

The last result implies that $q_m^2 \leq q_m$, and equality holds, i.e. $q_m^2 = q_m$, only when $q_m = 0$ or $q_m = 1$. The following holds [see Eq. (8.12)]

$$\text{Tr}(\rho) = \sum_m q_m = 1 , \quad (8.21)$$

and

$$\text{Tr}(\rho^2) = \sum_m q_m^2 , \quad (8.22)$$

hence

$$\text{Tr}(\rho^2) \leq \text{Tr}(\rho) = 1 . \quad (8.23)$$

Moreover, equality holds, i.e. $\text{Tr}(\rho^2) = 1$, only when

$$q_m = \begin{cases} 1 & m = m_0 \\ 0 & m \neq m_0 \end{cases} . \quad (8.24)$$

for some integer m_0 . For that case $\rho = |q_{m_0}\rangle \langle q_{m_0}|$, hence ρ represents a pure ensemble. On the other hand, the assumption that ρ represents a pure ensemble, i.e. the assumption that it can be expressed as $\rho = |\alpha\rangle \langle \alpha|$, implies that $\rho^2 = \rho$, hence $\text{Tr}(\rho^2) = 1$.

8.2 Time Evolution

Consider a density operator

$$\rho(t) = \sum_i w_i \left| \alpha^{(i)}(t) \right\rangle \left\langle \alpha^{(i)}(t) \right| , \quad (8.25)$$

where the state vectors $\{ \left| \alpha^{(i)}(t) \right\rangle \}$ evolve in time according to

$$i\hbar \frac{d \left| \alpha^{(i)} \right\rangle}{dt} = \mathcal{H} \left| \alpha^{(i)} \right\rangle , \quad (8.26)$$

$$-i\hbar \frac{d \left\langle \alpha^{(i)} \right|}{dt} = \left\langle \alpha^{(i)} \right| \mathcal{H} , \quad (8.27)$$

where \mathcal{H} is the Hamiltonian. Taking the time derivative yields

$$\frac{d\rho}{dt} = \frac{1}{i\hbar} \left(\sum_i w_i \mathcal{H} \left| \alpha^{(i)} \right\rangle \left\langle \alpha^{(i)}(t) \right| - \sum_i w_i \left| \alpha^{(i)}(t) \right\rangle \left\langle \alpha^{(i)} \right| \mathcal{H} \right) , \quad (8.28)$$

thus

$$\frac{d\rho}{dt} = -\frac{1}{i\hbar} [\rho, \mathcal{H}] . \quad (8.29)$$

This result resembles the equation of motion (4.37) of an observable in the Heisenberg representation, however, instead of a *minus* sign on the right hand side, Eq. (4.37) has a *plus* sign.

Alternatively, the time evolution of the operator ρ can be expressed in terms of the time evolution operator $u(t, t_0)$, which relates the state vector at time $\left| \alpha^{(i)}(t_0) \right\rangle$ with its value $\left| \alpha^{(i)}(t) \right\rangle$ at time t [see Eq. (4.4)]

$$\left| \alpha^{(i)}(t) \right\rangle = u(t, t_0) \left| \alpha^{(i)}(t_0) \right\rangle . \quad (8.30)$$

With the help of this relation Eq. (8.25) becomes

$$\rho(t) = u(t, t_0) \rho(t_0) u^\dagger(t, t_0) . \quad (8.31)$$

8.3 Quantum Statistical Mechanics

Consider an ensemble of identical copies of a quantum system. Let \mathcal{H} be the Hamiltonian having a set of eigenenergies $\{E_i\}$ and a corresponding set of eigenstates $\{|i\rangle\}$, which forms an orthonormal and complete basis

$$\mathcal{H} |i\rangle = E_i |i\rangle , \quad (8.32)$$

$$\sum_i |i\rangle \langle i| = 1 . \quad (8.33)$$

Consider the case where the ensemble is assumed to be a canonical ensemble in thermal equilibrium at temperature T . According to the laws of statistical mechanics the probability w_i to find an arbitrary system in the ensemble in a state vector $|i\rangle$ having energy E_i is given by

$$w_i = \frac{1}{Z} e^{-\beta E_i} , \quad (8.34)$$

where $\beta = 1/(k_B T)$, k_B is Boltzmann's constant, and where

$$Z = \sum_i e^{-\beta E_i} \quad (8.35)$$

is the partition function.

Exercise 8.3.1. Show that the density operator ρ can be written as

$$\rho = \frac{e^{-\beta \mathcal{H}}}{\text{Tr}(e^{-\beta \mathcal{H}})} . \quad (8.36)$$

Solution 8.3.1. According to the definition (8.11) one has

$$\rho = \sum_i w_i |i\rangle \langle i| = \frac{1}{Z} \sum_i e^{-\beta E_i} |i\rangle \langle i| . \quad (8.37)$$

Moreover, the following hold

$$Z = \sum_i e^{-\beta E_i} = \sum_i \langle i| e^{-\beta \mathcal{H}} |i\rangle = \text{Tr}(e^{-\beta \mathcal{H}}) , \quad (8.38)$$

and

$$\sum_i e^{-\beta E_i} |i\rangle \langle i| = \sum_i e^{-\beta \mathcal{H}} |i\rangle \langle i| = e^{-\beta \mathcal{H}} \sum_i |i\rangle \langle i| = e^{-\beta \mathcal{H}} , \quad (8.39)$$

thus

$$\rho = \frac{e^{-\beta \mathcal{H}}}{\text{Tr}(e^{-\beta \mathcal{H}})} . \quad (8.40)$$

As will be demonstrated below [see Eq. (8.622)], the last result for ρ can also be obtained from the principle of maximum entropy.

8.4 Problems

1. Prove that $\text{Tr}(AB)$ is real if both A and B are Hermitian.

2. Consider two pure states $\rho_1 = |\psi_1\rangle\langle\psi_1|$ and $\rho_2 = |\psi_2\rangle\langle\psi_2|$, where both $|\psi_1\rangle$ and $|\psi_2\rangle$ are normalized. The state ρ is defined by $\rho = \lambda\rho_1 + (1 - \lambda)\rho_2$, where $0 < \lambda < 1$. Show that ρ is pure if and only if $|\langle\psi_1|\psi_2\rangle| = 1$.
3. Consider a spin 1/2 in a magnetic field $\mathbf{B} = B\hat{\mathbf{z}}$ and in thermal equilibrium at temperature T . Calculate $\langle\mathbf{S} \cdot \hat{\mathbf{u}}\rangle$, where \mathbf{S} is the vector operator of the angular momentum and where $\hat{\mathbf{u}}$ is a unit vector, which can be described using the angles θ and ϕ

$$\hat{\mathbf{u}} = (\sin \theta \cos \phi, \sin \theta \sin \phi, \cos \theta) . \quad (8.41)$$

4. A spin 1/2 particle is in an eigenstate of the operator S_y with eigenvalue $+\hbar/2$.
 - a) Write the density operator in the basis of eigenvectors of the operator S_z .
 - b) Calculate ρ^n , where n is integer.
 - c) Calculate the density operator (in the same basis) of an ensemble of particles, half of them in an eigenstate of S_y with eigenvalue $+\hbar/2$, and half of them in an eigenstate of S_y with eigenvalue $-\hbar/2$.
 - d) Calculate ρ^n for this case.
5. A spin 1/2 is at time $t = 0$ in an eigenstate of the operator $S_\theta = S_x \sin \theta + S_z \cos \theta$ with an eigenvalue $+\hbar/2$, where θ is real and S_x and S_z are the x and z components, respectively, of the angular momentum vector operator. A magnetic field B is applied in the x direction between time $t = 0$ and time $t = T$.
 - a) The z component of the angular momentum is measured at time $t > T$. Calculate the probability P_+ to measure the value $\hbar/2$.
 - b) Calculate the density operator ρ of the spin at times $t = T$.
6. A spin 1/2 electron is put in a constant magnetic field given by $\mathbf{B} = B\hat{\mathbf{z}}$, where B is a constant. The system is in thermal equilibrium at temperature T .
 - a) Calculate the correlation function

$$C_z(t) = \langle S_z(t) S_z(0) \rangle . \quad (8.42)$$

- b) Calculate the correlation function

$$C_x(t) = \langle S_x(t) S_x(0) \rangle . \quad (8.43)$$

7. Express the density matrix ρ of a spin 1/2 system in terms of the expectations values $\langle\sigma_x\rangle$, $\langle\sigma_y\rangle$ and $\langle\sigma_z\rangle$, where σ_x , σ_y and σ_z are the Pauli's matrices.
8. Let ρ be a density operator given by Eq. (8.11). Show that for any normalized state $|\beta\rangle$ the following holds

$$0 \leq \langle\beta|\rho|\beta\rangle \leq 1 . \quad (8.44)$$

9. Let ρ be a density operator that can be expressed in terms of the density operators ρ_1 and ρ_2 as

$$\rho = \eta\rho_1 + (1 - \eta)\rho_2, \quad (8.45)$$

where

$$0 < \eta < 1. \quad (8.46)$$

Show that if ρ represents a pure state then

$$\rho_1 = \rho_2 = \rho. \quad (8.47)$$

10. Consider a harmonic oscillator with frequency ω . Show that the variance of the number operator $\Delta N = \sqrt{\langle N^2 \rangle - \langle N \rangle^2}$ (where $N = a^\dagger a$) is given by
- $\Delta N = 0$ for energy eigenstates.
 - $\Delta N = \sqrt{\langle N \rangle}$ for coherent states.
 - $\Delta N = \sqrt{\langle N \rangle (\langle N \rangle + 1)}$ for thermal states.
11. Consider a harmonic oscillator having angular resonance frequency ω . The oscillator is in thermal equilibrium at temperature T . Calculate the expectation value $\langle x^2 \rangle$.
12. Consider a particle having mass m confined by a one-dimensional potential $V(x)$, which is given by

$$V(x) = \begin{cases} \frac{m\omega^2}{2}x^2 & x > 0 \\ \infty & x \leq 0 \end{cases}, \quad (8.48)$$

where ω is a constant. Calculate the expectation value $\langle x^2 \rangle$ in thermal equilibrium at temperature T .

13. Consider a harmonic oscillator in thermal equilibrium at temperature T , whose Hamiltonian is given by

$$\mathcal{H} = \frac{p^2}{2m} + \frac{m\omega^2 x^2}{2}. \quad (8.49)$$

Show that the density operator is given by

$$\rho = \int \int d^2\alpha |\alpha\rangle \langle \alpha| P(\alpha), \quad (8.50)$$

where $|\alpha\rangle$ is a coherent state, $d^2\alpha$ denotes infinitesimal area in the α complex plane,

$$P(\alpha) = \frac{1}{\pi \langle N \rangle} \exp\left(-\frac{|\alpha|^2}{\langle N \rangle}\right), \quad (8.51)$$

and where $\langle N \rangle$ is the expectation value of the number operator N .

14. Consider a harmonic oscillator in thermal equilibrium at temperature T , whose Hamiltonian is given by

$$\mathcal{H} = \frac{p^2}{2m} + \frac{m\omega^2 x^2}{2} . \quad (8.52)$$

Calculate the probability distribution function $f(x)$ of the random variable x .

15. An LC oscillator (see figure) made of a capacitor C in parallel with an inductor L , is in thermal equilibrium at temperature T . The charge in the capacitor q is being measured.

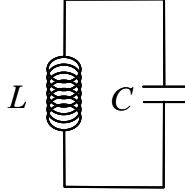

- a) Calculate the expectation value $\langle q \rangle$ of q .
 b) Calculate the variance $\langle (\Delta q)^2 \rangle$.
16. Consider an observable A having a set of eigenvalues $\{a_n\}$. Let P_n be a projector operator onto the eigensubspace corresponding to the eigenvalue a_n . A given physical system is initially described by the density operator ρ_0 . A measurement of the observable A is then performed. What is the density operator ρ_1 of the system immediately after the measurement?
17. A model that was proposed by von Neumann describes an indirect measurement process of a given observable A . The observable A is assumed to be a function of the degrees of freedom of a subsystem, which we refer to as the measured system (MS). The indirect measurement is performed by first letting the MS to interact with a measuring device (MD), having its own degrees of freedom, and then in the final step, performing a quantum measurement on the MD. The MS is assumed to initially be in a pure state $|\alpha\rangle$ (i.e. its density operator is assumed to initially be given by $\rho_0 = |\alpha\rangle\langle\alpha|$). Let A be an observable operating on the Hilbert space of the MS. The initial state of the MS can be expanded in the basis of eigenvectors $\{|a_n\rangle\}$ of the observable A

$$|\alpha\rangle = \sum_n c_n |a_n\rangle , \quad (8.53)$$

where $c_n = \langle a_n | \alpha \rangle$ and where

$$A |a_n\rangle = a_n |a_n\rangle . \quad (8.54)$$

For simplicity, the Hamiltonian of the MS is taken to be zero. The MD is assumed to be a one-dimensional free particle, whose Hamiltonian vanishes, and whose initial state is labeled by $|\psi_i\rangle$. The position wavefunction $\psi(x') = \langle x' | \psi_i \rangle$ of this state is taken to be Gaussian having width x_0

$$\psi(x') = \frac{1}{\pi^{1/4} x_0^{1/2}} \exp\left(-\frac{1}{2} \left(\frac{x'}{x_0}\right)^2\right). \quad (8.55)$$

The interaction between the MS and the MD is taken to be given by

$$V(t) = -f(t) x A, \quad (8.56)$$

where $f(t)$ is assumed to have compact support with a peak near the time of the measurement.

- a) Express the vector state of the entire system $|\Psi(t)\rangle$ at time t in the basis of states $\{|p'\rangle \otimes |a_{n'}\rangle\}$. This basis spans the Hilbert space of the entire system (MS and MD). The state $|p'\rangle \otimes |a_{n'}\rangle$ is both, an eigenvector of A (with eigenvalue a_n) and of the momentum p of the MD (with eigenvalue p').
- b) In what follows the final state of the system after the measurement will be evaluated by taking the limit $t \rightarrow \infty$. The outcome of the measurement of the observable A , which is labeled by \mathcal{A} , is determined by performing a measurement of the momentum variable p of the MD. The outcome, which is labeled by \mathcal{P} , is related to \mathcal{A} by

$$\mathcal{A} = \frac{\mathcal{P}}{p_i}, \quad (8.57)$$

where

$$p_i = \int_{-\infty}^{\infty} dt' f(t'). \quad (8.58)$$

Calculate the probability distribution $g(\mathcal{A})$ of the random variable \mathcal{A} .

- c) Consider another measurement that is performed after the entanglement between the MS and the MD has been fully created. The additional measurement is associated with the observable B , which is assumed to be a function of the degrees of freedom of the MS only. Show that the expectation value \bar{B} of the observable B is given by

$$\bar{B} = \sum_{n'} \langle a_{n'} | B \rho_{\text{R}} | a_{n'} \rangle, \quad (8.59)$$

where the operator ρ_{R} , which is called the reduced density operator, is given by

$$\rho_{\text{R}} = \sum_{n', n''} c_{n'} c_{n''}^* e^{-\eta^2 \left(\frac{a_{n'} - a_{n''}}{2}\right)^2} |a_{n'}\rangle \langle a_{n''}|. \quad (8.60)$$

18. Consider a system composed of a two-level system and a harmonic oscillator. The state $|\psi\rangle$ of the combined system is assumed to be given by

$$|\psi\rangle = a_g |g\rangle |\alpha_g\rangle + a_e |e\rangle |\alpha_e\rangle , \quad (8.61)$$

where $|g\rangle$ and $|e\rangle$ are normalized two-level system states orthogonal to each other, $|\alpha_g\rangle$ and $|\alpha_e\rangle$ are two normalized coherent states of the harmonic oscillator, and a_g and a_e are complex numbers. Calculate $\text{Tr} \rho_R^2$, where ρ_R is the reduced density matrix of the two-level system.

19. A particle having mass m moves in the xy plane under the influence of a two-dimensional potential $V(x, y)$, which is given by

$$V(x, y) = \frac{m\omega^2}{2} (x^2 + y^2) + \lambda m\omega^2 xy , \quad (8.62)$$

where both ω and λ are real constants. Calculate in thermal equilibrium at temperature T the expectation values $\langle x \rangle$, $\langle x^2 \rangle$.

20. Consider a harmonic oscillator having angular resonance frequency ω and mass m . Calculate the correlation function $G(t) = \langle x_{(\text{H})}(t) x_{(\text{H})}(0) \rangle$, where $x_{(\text{H})}(t)$ is the Heisenberg representation of the position operator, for the cases where
- the oscillator is in its ground state.
 - the oscillator is in thermal equilibrium at temperature T .
21. In general, the Wigner function of a point particle moving in one dimension is given by

$$W(x', p') = \frac{1}{2\pi} \int_{-\infty}^{\infty} dx'' \exp\left(i\frac{p'x''}{\hbar}\right) \left\langle x' - \frac{x''}{2} \left| \rho \right| x' + \frac{x''}{2} \right\rangle , \quad (8.63)$$

where ρ is the density operator of the system, and where $|x'\rangle$ represents an eigenvector of the position operator x having eigenvalue x' , i.e. $x|x'\rangle = x'|x'\rangle$. As can be seen from Eq. (4.332), the Wigner function is the inverse Weyl transformation of the density operator divided by the factor of 2π . Consider the case of a point particle having mass m in a potential of a harmonic oscillator having angular frequency ω . Calculate the Wigner function $W(x', p')$ for the case where the system is in a coherent state $|\alpha\rangle$.

22. A particle having mass m is in the ground state of the one-dimensional potential well $V_1(x) = (1/2)m\omega^2(x - \Delta_x)^2$ for times $t < 0$. At time $t = 0$ the potential suddenly changes and becomes $V_2(x) = (1/2)m\omega^2x^2$. Calculate the Wigner function of the system at times $t > 0$.
23. Consider a point particle having mass m in a potential of a harmonic oscillator having angular frequency ω . Calculate the Wigner function $W(x', p')$ for the case where the system is in thermal equilibrium at temperature T .

24. Consider a point particle having mass m in a potential of a harmonic oscillator having angular frequency ω . Calculate the Wigner function $W(x', p')$ for the case where the system is in the number state $|n = 1\rangle$.
25. The Wigner function of a point particle moving in one dimension is given by Eq. (8.63). Show that the marginal distributions $\langle x' | \rho | x' \rangle$ and $\langle p' | \rho | p' \rangle$ of the position x and momentum p observables, respectively, are given by

$$\langle x' | \rho | x' \rangle = \hbar^{-1} \int_{-\infty}^{\infty} dp' W(x', p') , \quad (8.64)$$

$$\langle p' | \rho | p' \rangle = \hbar^{-1} \int_{-\infty}^{\infty} dx' W(x', p') . \quad (8.65)$$

26. Show that for a pure state the Wigner function is bounded by $|W(x', p')| \leq 1/2\pi$. Note that this bound together with Eqs. (8.64) and (8.65) can be used to demonstrate the uncertainty principle (3.10).
27. Consider a particle having mass m moving along the x axis under the influence of the potential $V(x)$. Show that the time evolution of the Wigner function W (8.63) is governed by

$$\frac{dW}{dt} = \{\mathcal{H}, W\} + \sum_{l=1}^{\infty} \frac{\left(\frac{\hbar}{2i}\right)^{2l}}{(2l+1)!} \frac{\partial^{2l+1} V}{\partial (x')^{2l+1}} \frac{\partial^{2l+1} W}{\partial (p')^{2l+1}} , \quad (8.66)$$

where \mathcal{H} is the Hamiltonian and $\{\mathcal{H}, W\}$ is the Poisson's brackets of \mathcal{H} and W .

28. The function $W(X', P')$ is defined as the inverse Fourier transform of the function $\tilde{W}(\xi, \eta)$

$$W(X', P') = \frac{1}{(2\pi)^2} \int_{-\infty}^{\infty} \int_{-\infty}^{\infty} d\xi d\eta \tilde{W}(\xi, \eta) e^{i\xi X' + i\eta P'} , \quad (8.67)$$

where the function $\tilde{W}(\xi, \eta)$ is given by

$$\tilde{W}(\xi, \eta) = \text{Tr} [\exp(-i\xi X - i\eta P) \rho] , \quad (8.68)$$

X and P are dimensionless position and momentum operators, which are given by

$$X = \frac{a + a^\dagger}{\sqrt{2}} , \quad P = \frac{a - a^\dagger}{i\sqrt{2}} , \quad (8.69)$$

and which satisfy $[X, P] = i$ [see Eq. (5.13)] and ρ is the density operator. Show that

$$W(X', P') = \frac{1}{2\pi} \int_{-\infty}^{\infty} dX'' \left\langle X' - \frac{X''}{2} \left| \rho \right| X' + \frac{X''}{2} \right\rangle e^{iX'' P'} , \quad (8.70)$$

i.e. show that $W(X', P')$ is the Wigner function expressed in terms of the dimensionless variables X' and P' [whereas Eq. (8.63) is the Wigner function expressed in terms of the position x' and momentum p' variables].

29. Equation (8.67) can be rewritten as

$$W(X', P') = \text{Tr}(\mathcal{Y}\rho) , \quad (8.71)$$

where the operator \mathcal{Y} is given by

$$\mathcal{Y}(X', P') = \frac{1}{(2\pi)^2} \int_{-\infty}^{\infty} \int_{-\infty}^{\infty} d\xi d\eta e^{i\xi(X'-X)+i\eta(P'-P)} . \quad (8.72)$$

Note that the operator \mathcal{Y} given by Eq. (8.72) is the dimensionless version of the Weyl kernel (4.46), which defines the Weyl transformation (4.45). Show that

$$\mathcal{Y}(X', P') = \pi^{-1} D^\dagger \left(-\frac{X' + iP'}{\sqrt{2}} \right) \mathcal{P} D \left(-\frac{X' + iP'}{\sqrt{2}} \right) , \quad (8.73)$$

where

$$D(\alpha) = \exp(\alpha a^\dagger - \alpha^* a) \quad (8.74)$$

is the displacement operator [see Eq. (5.36)], a is the annihilation operator and

$$\mathcal{P} = \int_{-\infty}^{\infty} dX' |X'\rangle \langle -X'| \quad (8.75)$$

is the parity operator [see Eq. (5.111)], where $|X'\rangle$ is an eigenvector of the dimensionless position operator X having eigenvalue X' , i.e. $X|X'\rangle = X'|X'\rangle$.

30. **Operator-valued delta function** - For a given function $\mathcal{F}(\alpha', \alpha'^*)$, where α' is a complex number and α'^* is its complex conjugate, the operator $f(a, a^\dagger)$ is defined by [compare with the Weyl transformation (4.45)]

$$f(a, a^\dagger) = \frac{1}{\pi^2} \int d^2\alpha' \int d^2\alpha'' e^{(a^\dagger - \alpha'^*)\alpha'' - (a - \alpha')\alpha''^*} \mathcal{F}(\alpha', \alpha'^*) , \quad (8.76)$$

where a is the annihilation operator, both α' and α'' are complex, and $d^2\alpha$ denotes infinitesimal area in the α complex plane, i.e. $d^2\alpha = d\{\text{Re } \alpha\} d\{\text{Im } \alpha\}$. Alternatively, the operator $f(a, a^\dagger)$ can be expressed as

$$f(a, a^\dagger) = \int d^2\alpha' \hat{\delta}(a - \alpha') \mathcal{F}(\alpha', \alpha'^*) , \quad (8.77)$$

where the operator $\hat{\delta}(a - \alpha')$, which is called the operator-valued delta function, is given by

$$\hat{\delta}(a - \alpha') = \frac{1}{\pi^2} \int d^2\alpha'' e^{(a^\dagger - \alpha'^*)\alpha'' - (a - \alpha')\alpha''^*} . \quad (8.78)$$

a) Show that

$$\text{Tr} \left[\hat{\delta}(a - \alpha') \hat{\delta}(a - \alpha'') \right] = \frac{1}{\pi} \delta(\alpha' - \alpha'') . \quad (8.79)$$

b) Show that

$$\mathcal{F}(\alpha', \alpha'^*) = \pi \text{Tr} \left[\hat{\delta}(a - \alpha') f(a, a^\dagger) \right] . \quad (8.80)$$

c) **Wigner function** - Show that

$$\text{Tr} \left[\hat{\delta}(a - \alpha') \rho \right] = 2w(\alpha') , \quad (8.81)$$

where ρ is the density operator, the function $w(\alpha')$ is given by

$$w(\alpha') = W \left(\frac{\alpha' + \alpha'^*}{\sqrt{2}}, \frac{\alpha' - \alpha'^*}{i\sqrt{2}} \right) , \quad (8.82)$$

and $W(X', P')$ is the Wigner function (8.67).

d) **Husimi function** - Show that the Husimi Q function, which for a given density operator ρ is defined by

$$Q(\alpha) = \frac{1}{\pi} \langle \alpha | \rho | \alpha \rangle , \quad (8.83)$$

where $|\alpha\rangle$ is a coherent state, is related to the Wigner function $w(\alpha')$ (8.82) by

$$Q(\alpha) = \frac{4}{\pi} \int d^2\alpha' w(\alpha') e^{-\frac{|\alpha' - \alpha|^2}{2}} . \quad (8.84)$$

31. **Homodyne Tomography** - Consider a point particle having mass m in a potential of a harmonic oscillator having angular frequency ω . The normalized homodyne observable X_ϕ with a real phase ϕ is defined by

$$X_\phi = \frac{a^\dagger e^{i\phi} + a e^{-i\phi}}{\sqrt{2}} , \quad (8.85)$$

where a and a^\dagger are annihilation and creation operators [see Eqs. (5.9) and (5.10)]. Let $w(X'_\phi)$ be the normalized probability distribution function of the observable X_ϕ . The technique of homodyne detection can be used to measure $w(X'_\phi)$ for any given value of the phase ϕ .

- a) To generalize Eqs. (8.64) and (8.65) show that the following holds for any real ϕ

$$w(X'_\phi) = \int_{-\infty}^{\infty} dP'_\phi W(X'_\phi \cos \phi - P'_\phi \sin \phi, X'_\phi \sin \phi + P'_\phi \cos \phi) . \quad (8.86)$$

- b) Show that the Wigner function (8.63) can be extracted from the measured distributions $w(X'_\phi)$ for all values of ϕ .
32. Consider a harmonic oscillator in thermal equilibrium at temperature T , whose Hamiltonian is given by

$$\mathcal{H} = \frac{p^2}{2m} + \frac{m\omega^2 x^2}{2} . \quad (8.87)$$

Calculate the matrix elements $\langle x'' | \rho | x' \rangle$ of the density operator in the basis of eigenvectors of the position operator x .

33. Consider a harmonic oscillator having angular resonance frequency ω . The oscillator is in thermal equilibrium at temperature T . Calculate the expectation value $\langle e^{-i\zeta X_\phi} \rangle$, where X_ϕ is given by [see Eq. (8.85)]

$$X_\phi = \frac{a^\dagger e^{i\phi} + a e^{-i\phi}}{\sqrt{2}} , \quad (8.88)$$

a and a^\dagger are annihilation and creation operators [see Eqs. (5.9) and (5.10)] and both ϕ and ζ are real. Use your result for the expectation value $\langle e^{-i\zeta X_\phi} \rangle$ to evaluate the Wigner function of the system.

34. Show that when $w(X'_\phi)$ is ϕ independent the following holds

$$W(X', P') = \frac{1}{2\pi} \int_0^\infty d\zeta \zeta \tilde{w}(\zeta) J_0(\zeta \sqrt{X'^2 + P'^2}) , \quad (8.89)$$

where $\tilde{w}(\zeta)$ is the (ϕ independent) Fourier transform of $w(X'_\phi)$, i.e.

$$\tilde{w}(\zeta) = \int_{-\infty}^{\infty} dX'_\phi w(X'_\phi) e^{-i\zeta X'_\phi} . \quad (8.90)$$

35. Consider a point particle having mass m in a potential of a harmonic oscillator having angular frequency ω . Express the Wigner function $W(X', P'; t)$ at time t in terms of the Wigner function $W(X', P'; 0)$ at time $t = 0$.

36. Let $W(X', P')$ be the Wigner function of a system whose density operator is ρ . Express the Wigner function $W_\alpha(X', P')$ of a system whose density operator is displaced according to $\rho_\alpha = D(\alpha') \rho D^\dagger(\alpha')$, where $D(\alpha') = \exp(\alpha' a^\dagger - \alpha'^* a)$ is the displacement operator [see Eq. (5.36)], and where α' is complex, in terms of the Wigner function of the undisplaced system $W(X', P')$.
37. Consider a weak measurement of the dimensionless position X [see Eq. (8.69)] of a point particle moving in one dimension. In view of Eq. (8.60), the reduced density operator of the system after the measurement, which is labeled as ρ_R , is expected to be related to the density operator before the measurement ρ by the following relation

$$\left\langle X' - \frac{X''}{2} \left| \rho_R \right| X' + \frac{X''}{2} \right\rangle = \left\langle X' - \frac{X''}{2} \left| \rho \right| X' + \frac{X''}{2} \right\rangle e^{-\left(\frac{\eta X''}{2}\right)^2}, \quad (8.91)$$

where the dimensionless parameter η characterizes the strength of the measurement, and where $|X'\rangle$ represents an eigenvector of the dimensionless position operator X [see Eq. (8.69)] having eigenvalue X' , i.e. $X|X'\rangle = X'|X'\rangle$. Express the reduced Wigner function $W_R(X', P')$, which is given by [see Eq. (8.70)]

$$W_R(X', P') = \frac{1}{2\pi} \int_{-\infty}^{\infty} dX'' \left\langle X' - \frac{X''}{2} \left| \rho_R \right| X' + \frac{X''}{2} \right\rangle e^{iX''P'}, \quad (8.92)$$

in terms of the Wigner function $W(X', P')$ before the measurement.

38. **Schrödinger cat** - The normalized state $|\psi\rangle$ is given by

$$|\psi\rangle = C(|\alpha_0 + \alpha\rangle + |\alpha_0 - \alpha\rangle), \quad (8.93)$$

where C is a normalization constant, $|\alpha_0 + \alpha\rangle$ and $|\alpha_0 - \alpha\rangle$ are coherent states, and $\alpha_0, \alpha \in \mathcal{C}$. Calculate the Wigner function W_0 of the corresponding density operator $\rho_0 = |\psi\rangle\langle\psi|$.

39. The normalized state $|\psi\rangle$ is given by

$$|\psi\rangle = C(|\alpha\rangle + |-\alpha\rangle), \quad (8.94)$$

where C is a normalization constant, $|\alpha\rangle$ and $|-\alpha\rangle$ are coherent states, and $\alpha \in \mathcal{C}$. Calculate the normalized second-order correlation function $g^{(2)}$ with respect to the state $|\psi\rangle$, which is defined by [see Eq. (5.94)]

$$g^{(2)} = \frac{\langle\psi| a^\dagger a^\dagger a a |\psi\rangle}{\langle\psi| a^\dagger a |\psi\rangle^2}. \quad (8.95)$$

where a and a^\dagger are the harmonic oscillator annihilation and creation operators respectively.

40. A point particle having mass m is confined by the three dimensional potential

$$V(r) = \frac{1}{2}m\omega^2 r^2, \quad (8.96)$$

where $r = \sqrt{x^2 + y^2 + z^2}$ and where ω is a real constant. Calculate $\langle x \rangle$ and $\langle x^2 \rangle$ in thermal equilibrium at temperature T .

41. **Successive measurements** - Consider a system whose density operator is denoted by ρ and its time evolution operator is denoted by u . Two measurements are performed. In the first one, which is performed at time $t_1 \geq t_0$, the observable A_1 is being measured (t_0 is an initial time), whereas in the second one, which is performed at a later time $t_2 \geq t_1$, the observable A_2 is being measured. Let \mathcal{A}_1 be the outcome of the first measurement and \mathcal{A}_2 the outcome of the second one. Moreover, let $\{a_{n,k}\}_k$ be the set of eigenvalues of the observable A_n , where $n \in \{1, 2\}$.
- Calculate the probability $p_1(k_1)$ that the measurement at time t_1 of the observable A_1 yields the value a_{1,k_1} , i.e. $\mathcal{A}_1 = a_{1,k_1}$.
 - Calculate the probability $p_2(k_2)$ that the measurement at time t_2 of the observable A_2 yields the value a_{2,k_2} , i.e. $\mathcal{A}_2 = a_{2,k_2}$.
 - Show that the probability $p_2(k_2)$ for the measurement at time t_2 is unaffected by the collapse due to the earlier measurement at time t_1 provided that $[\rho_0, A_1(t_1)] = 0$, where $\rho_0 = \rho(t_0)$ is the density operator at initial time t_0 and $A_1(t_1)$ is a time dependent Heisenberg operator.
 - Show that the probability $p_2(k_2)$ for the measurement at time t_2 is unaffected by the collapse due to the earlier measurement at time t_1 provided that $[A_2(t_2), A_1(t_1)] = 0$, where $A_1(t_1)$ and $A_2(t_2)$ are time dependent Heisenberg operators.
42. The entropy σ is defined by

$$\sigma = -\text{Tr}(\rho \log \rho). \quad (8.97)$$

Show that σ is time independent.

43. The matrix representation in the basis of eigenvectors of S_z of the density operator of a spin 1/2 particle is given by

$$\rho = \frac{1}{2}(1 + \mathbf{k} \cdot \boldsymbol{\sigma}), \quad (8.98)$$

where $\mathbf{k} = (k_x, k_y, k_z)$ is a three dimensional vector of real numbers, and $\boldsymbol{\sigma} = (\sigma_x, \sigma_y, \sigma_z)$ is the Pauli matrix vector. The entropy σ is defined by

$$\sigma = -\text{Tr}(\rho \log \rho). \quad (8.99)$$

- Calculate σ .

- b) A measurement of S_z is performed. Calculate the entropy after the measurement.
44. The matrix representation H of the Hamiltonian of a spin $1/2$ particle is expressed as

$$\hbar^{-1}H = \omega_0 + \boldsymbol{\omega} \cdot \boldsymbol{\sigma} , \quad (8.100)$$

where ω_0 is a real number, $\boldsymbol{\omega} = (\omega_x, \omega_y, \omega_z)$ is a real vector, and $\boldsymbol{\sigma} = (\sigma_x, \sigma_y, \sigma_z)$ is the Pauli matrix vector [see Eq. (6.137)]. Similarly, the 2×2 density matrix ρ is expressed as

$$\rho = \frac{1}{2} (1 + \mathbf{k} \cdot \boldsymbol{\sigma}) , \quad (8.101)$$

where $\mathbf{k} = (k_x, k_y, k_z)$ is a real vector. Derive an equation of motion for the vector \mathbf{k} .

45. The matrix representation of the density operator ρ_0 of a spin $1/2$ particle is given by

$$\rho_0 = \frac{1 + \gamma \hat{\mathbf{n}}_0 \cdot \boldsymbol{\sigma}}{2} , \quad (8.102)$$

where $\boldsymbol{\sigma} = (\sigma_x, \sigma_y, \sigma_z)$ is the Pauli matrix vector and $\hat{\mathbf{n}}_0$ is a unit vector, i.e. $\hat{\mathbf{n}}_0 \cdot \hat{\mathbf{n}}_0 = 1$.

- a) Under what conditions ρ_0 represents a pure state?
- b) What is the probability p_1 to find the spin pointing in the $\hat{\mathbf{n}}_1$ direction, where $\hat{\mathbf{n}}_1$ is a unit vector?
- c) After the first measurement a second measurement is performed. What is the probability p_2 to find the spin in the second measurement pointing in the $\hat{\mathbf{n}}_2$ direction, where $\hat{\mathbf{n}}_2$ is a unit vector?
46. **The maximum entropy principle** - The entropy σ is defined by

$$\sigma(\rho) = -\text{Tr}(\rho \log \rho) . \quad (8.103)$$

Consider the case where the density matrix is assumed to satisfy a set of constraints, which are expressed as

$$g_l(\rho) = 0 , \quad (8.104)$$

where $l = 0, 1, \dots, L$. The functionals $g_l(\rho)$ maps the density operator ρ to a complex number, i.e. $g_l(\rho) \in \mathcal{C}$.

- a) Find an expression for a density matrix that satisfies all these constraints, for which the entropy σ obtains a stationary point (maximum, minimum or a saddle point). Assume that the constraint $l = 0$ is the requirement that $\text{Tr}(\rho) = 1$, i.e. $g_0(\rho)$ can be taken to be given by

$$g_0(\rho) = \text{Tr}(\rho) - 1 = 0 . \quad (8.105)$$

Moreover, assume that the other constrains $l = 1, \dots, L$ are the requirements that the expectation values of the Hermitian operators X_1, X_2, \dots, X_L are the following real numbers $\mathcal{X}_1, \mathcal{X}_2, \dots, \mathcal{X}_L$ respectively, i.e. $g_l(\rho)$ for $l \geq 1$ can be taken to be given by

$$g_l(\rho) = \text{Tr}(\rho X_l) - \mathcal{X}_l = 0. \quad (8.106)$$

- b) Express ρ for the case of a *microcanonical* ensemble, for which the only required constrain is (8.105).
 c) Express ρ for the case of a *canonical* ensemble, for which in addition to the constrain is (8.105) the expectation value of the Hamiltonian \mathcal{H} is required to have a given value, which is labeled by $\langle \mathcal{H} \rangle$.
 d) Express ρ for the case of a *grandcanonical* ensemble, for which in addition to the constrain is (8.105) the expectation values of the Hamiltonian \mathcal{H} and of the operator N are required to have given values, which are labeled by $\langle \mathcal{H} \rangle$ and $\langle N \rangle$ respectively. The operator N , which will be defined in chapter 16, is called the number of particles operator.
47. **Relative entropy** - For two given density operators ρ' and ρ'' , the relative entropy $S(\rho' \parallel \rho'')$ is defined by

$$S(\rho' \parallel \rho'') = \text{Tr}(\rho' (\log \rho' - \log \rho'')) . \quad (8.107)$$

- a) Show that

$$S(\rho' \parallel \rho'') \geq 0. \quad (8.108)$$

- b) **Bogoliubov inequality** - For two given Hermitian Hamiltonians \mathcal{H}' and \mathcal{H}'' , show that

$$\text{Tr}(\rho'' (\mathcal{H}'' - \mathcal{H}')) \leq \frac{1}{\beta} \log \frac{\text{Tr}(e^{-\beta \mathcal{H}'})}{\text{Tr}(e^{-\beta \mathcal{H}''})} \leq \text{Tr}(\rho' (\mathcal{H}'' - \mathcal{H}')) , \quad (8.109)$$

where [see Eq. (8.40)]

$$\rho' = \frac{e^{-\beta \mathcal{H}'}}{\text{Tr}(e^{-\beta \mathcal{H}'})} , \quad (8.110)$$

$$\rho'' = \frac{e^{-\beta \mathcal{H}''}}{\text{Tr}(e^{-\beta \mathcal{H}''})} . \quad (8.111)$$

48. Consider a point particle having mass m moving in one dimension under the influence of the potential $V(x)$. Calculate the canonical partition function Z_c [see Eq. (8.623)] in the classical limit, i.e. in the limit of high temperature.
49. The state $|\alpha\rangle$ of a physical system is prepared in a random process that has two possible outcomes. For the first outcome, which has probability p_1 , the system is prepared in the state $|\alpha_1\rangle$ (i.e. $|\alpha\rangle = |\alpha_1\rangle$), and for the

second one, which has probability $p_2 = 1 - p_1$, the system is prepared in the state $|\alpha_2\rangle$ (i.e. $|\alpha\rangle = |\alpha_2\rangle$). A measurement of the observable $P_\beta = |\beta\rangle\langle\beta|$ is performed. The result of this measurement is denoted by B . The states $|\alpha_1\rangle$, $|\alpha_2\rangle$ and $|\beta\rangle$ are all normalized.

- Calculate the probabilities of all possible results B of the measurement of the observable P_β .
- Let B' be a possible result of the measurement of P_β . Calculate the conditional probabilities $p(|\alpha\rangle = |\alpha_1\rangle | B = B')$ and $p(|\alpha\rangle = |\alpha_2\rangle | B = B')$ for all possible values of B' . Note that $p(|\alpha\rangle = |\alpha_1\rangle | B = B')$ ($p(|\alpha\rangle = |\alpha_2\rangle | B = B')$) is the probability that the system has been prepared in the state $|\alpha_1\rangle$ ($|\alpha_2\rangle$) given that the value B' has been measured, i.e. $B = B'$.
- Shannon entropy and mutual information** - The entropy, which is defined by Eq. (8.97), can be used to quantify information. In particular, the information regarding the initial state $|\alpha\rangle$ of the system prior to the measurement of the observable P_β is quantified by the entropy S_i , which is given by

$$S_i = -p_1 \log p_1 - p_2 \log p_2 . \quad (8.112)$$

Likewise, the entropies $S_{B'}$ quantify the information regarding the initial state $|\alpha\rangle$ of the system after the measurement of the observable P_β , given that $B = B'$, i.e. given that the value B' has been measured. The average entropy S_f after the measurement of P_β is calculated according to

$$S_f = \sum_{B'} p(B = B') S_{B'} , \quad (8.113)$$

where $p(B = B')$ is the probability that $B = B'$. Calculate the information gained regarding the initial state $|\alpha\rangle$ by performing the measurement of the observable P_β , i.e. calculate $S_f - S_i$.

50. **Composite system** - Let ρ be the density operator of a given system. The system is composed of two subsystems, each having its own degrees of freedom, which are labeled as '1' and '2' (e.g. a system of two particles). Let $\{|n_1\rangle_1\}$ ($\{|n_2\rangle_2\}$) be an orthonormal basis spanning the Hilbert space of subsystem '1' ('2'). The set of vectors $\{|n_1, n_2\rangle\}$, where $|n_1, n_2\rangle = |n_1\rangle_1 \otimes |n_2\rangle_2$, forms an orthonormal basis spanning the Hilbert space of the combined system, where the symbol \otimes denotes tensor product. For a general operator O the partial trace over subsystem '1' is defined by the following relation

$$\text{Tr}_1(O) \equiv \sum_{n_1} \langle n_1 | O | n_1 \rangle_1 . \quad (8.114)$$

Similarly, the partial trace over subsystem '2' is defined by

$$\text{Tr}_2(O) \equiv \sum_{n_2} {}_2 \langle n_2 | O | n_2 \rangle_2 . \quad (8.115)$$

The observable A_1 is a given Hermitian operator on the Hilbert space of subsystem '1'. Show that the expectation value of a measurement of A_1 that is performed on subsystem '1' is given by

$$\langle A_1 \rangle = \text{Tr}_1(\rho_1 A_1) . \quad (8.116)$$

where the operator ρ_1 , which is given by

$$\rho_1 = \text{Tr}_2 \rho , \quad (8.117)$$

is called the reduced density operator of subsystem '1'.

51. **The Schmidt decomposition** - Consider a system composed of two subsystems labeled as '1' and '2'. The dimensionality of the Hilbert spaces of both subsystems, which is denoted by N_1 and N_2 , respectively, is assumed to be finite. The system is in a normalized pure state vector $|\psi\rangle$ given by

$$|\psi\rangle = \mathcal{K}_1 C \otimes \mathcal{K}_2^T , \quad (8.118)$$

where C is a $N_1 \times N_2$ matrix having entries C_{k_1, k_2} , matrix transposition is denoted by T, the row vectors \mathcal{K}_1 and \mathcal{K}_2 are given by

$$\mathcal{K}_1 = (|k_1\rangle_1, |k_2\rangle_1, \dots, |k_{N_1}\rangle_1) , \quad (8.119)$$

$$\mathcal{K}_2 = (|k_1\rangle_2, |k_2\rangle_2, \dots, |k_{N_2}\rangle_2) , \quad (8.120)$$

and $\{|k_1\rangle_1\}$ ($\{|k_2\rangle_2\}$) is an orthonormal basis spanning the Hilbert space of subsystem '1' ('2').

- a) The purity P_1 (P_2) is defined by $P_1 = \text{Tr} \rho_1^2$ ($P_2 = \text{Tr} \rho_2^2$), where $\rho_1 = \text{Tr}_2 \rho$ ($\rho_2 = \text{Tr}_1 \rho$) is the reduced density operator of the first (second) subsystems [see Eq. (8.117)], and where ρ is the density operator of the whole system. Show that $P_1 = P_2 \equiv P$, and that the level of entanglement Q , which is defined by $Q = 1 - P$, is given by

$$Q = 2 \sum_{k'_1 < k''_1} \sum_{k'_2 < k''_2} |\langle \Psi_{k'_1, k''_1, k'_2, k''_2} | \psi \rangle|^2 , \quad (8.121)$$

where the state $\langle \Psi_{k'_1, k''_1, k'_2, k''_2} |$, which depends on on the matrix C corresponding to a given state $|\psi\rangle$, is given by (note that $\langle \Psi_{k'_1, k''_1, k'_2, k''_2} |$ is not normalized)

$$\langle \Psi_{k'_1, k''_1, k'_2, k''_2} | = C_{k''_1, k'_1} \langle k'_1, k'_2 | - C_{k''_1, k'_2} \langle k'_1, k''_2 | . \quad (8.122)$$

- b) Calculate the entropy of the two subsystems, σ_1 and σ_2 , respectively.

- c) Calculate ρ_1 , ρ_2 , σ_1 , σ_2 and Q for a two spin 1/2 system in a pure state $|\psi\rangle$ given by

$$|\psi\rangle = a |--\rangle + b |-\rangle + c |+-\rangle + d |++\rangle . \quad (8.123)$$

- d) Express the results of the previous section for the pure states $|A_{\pm}\rangle$ and $|P_{\pm}\rangle$, which are given by (these states are commonly called Bell states)

$$|A_{\pm}\rangle = \frac{|+-\rangle \pm |--\rangle}{\sqrt{2}} , \quad (8.124)$$

$$|P_{\pm}\rangle = \frac{|++\rangle \pm |--\rangle}{\sqrt{2}} . \quad (8.125)$$

52. Consider a two spin 1/2 system in a pure normalized state $|\psi\rangle$ given by [see Eq. (8.123)]

$$|\psi\rangle = a |--\rangle + b |-\rangle + c |+-\rangle + d |++\rangle . \quad (8.126)$$

Calculate $(2/\hbar)^2 \left(|\langle \mathbf{S}_1 \rangle|^2 - |\langle \mathbf{S}_2 \rangle|^2 \right)$, where $\mathbf{S}_1 = (S_{1x}, S_{1y}, S_{1z})$ and $\mathbf{S}_2 = (S_{2x}, S_{2y}, S_{2z})$ are the angular momentum vector operators of the first and second spin, respectively.

53. A state vector $|\Phi(t)\rangle$ of a system comprising of two spin 1/2 particles is expressed as

$$|\Phi(t)\rangle = a(t) |--\rangle + b(t) |-\rangle + c(t) |+-\rangle + d(t) |++\rangle , \quad (8.127)$$

where the coefficients $a(t)$, $b(t)$, $c(t)$ and $d(t)$ are functions of the time t .

- a) Show that $\kappa(t) \equiv a(t)d(t) - b(t)c(t)$ is time independent, provided that the spins are decoupled.
b) In the basis of the Bell states $|\Phi(t)\rangle$ is expressed as

$$|\Phi(t)\rangle = \alpha(t) |A_{-}\rangle + \beta(t) |A_{+}\rangle + \gamma(t) |P_{-}\rangle + \delta(t) |P_{+}\rangle , \quad (8.128)$$

where $|A_{\pm}\rangle$ and $|P_{\pm}\rangle$ are given by Eqs. (8.124) and (8.125), respectively. Show that $\eta(t) \equiv \alpha^2(t) - \beta^2(t) - \gamma^2(t) + \delta^2(t)$ is time independent, provided that the spins are decoupled.

54. Consider a system composed of a two-level subsystem (labeled as s), and an ancilla subsystem (labeled as o). The normalized state vector $|\psi\rangle$ is given by

$$|\psi\rangle = a |as\rangle |ao\rangle + b |bs\rangle |bo\rangle , \quad (8.129)$$

where $|as\rangle \doteq (a_1, a_2)^T$ and $|bs\rangle \doteq (b_1, b_2)^T$ are normalized two-level subsystem states, $|ao\rangle$ and $|bo\rangle$ are normalized ancilla subsystem states, and a and b are complex. Find a Schmidt decomposition for $|\psi\rangle$.

55. Consider a system comprising of two spin 1/2 particles. The Hamiltonian \mathcal{H} is given by

$$\mathcal{H} = \frac{\omega}{\hbar} (\mathbf{S}_1 \cdot \mathbf{S}_2 + \eta S_{1z} S_{2z}) , \quad (8.130)$$

where both ω and η are real constants, and $\mathbf{S}_1 = (S_{1x}, S_{1y}, S_{1z})$ and $\mathbf{S}_2 = (S_{2x}, S_{2y}, S_{2z})$ are the angular momentum vector operators of the first and second spin respectively.

- a) Calculate $\langle \mathcal{H} \rangle$ for the case where the system is in a pure normalized state $|\psi\rangle$ given by [see Eq. (8.123)]

$$|\psi\rangle = a |--\rangle + b | -+\rangle + c |+-\rangle + d |++\rangle . \quad (8.131)$$

- b) Consider the case where the system is in thermal equilibrium at temperature T . For the case $\eta = 0$, calculate $\langle \hat{\mathbf{n}}_1, \hat{\mathbf{n}}_2 | \rho | \hat{\mathbf{n}}_1, \hat{\mathbf{n}}_2 \rangle$, where $|\hat{\mathbf{n}}_1, \hat{\mathbf{n}}_2\rangle$ is a two-spin coherent state [see Eq. (6.201)], $\hat{\mathbf{n}}_1 = (\sin \theta_1 \cos \varphi_1, \sin \theta_1 \sin \varphi_1, \cos \theta_1)$ and $\hat{\mathbf{n}}_2 = (\sin \theta_2 \cos \varphi_2, \sin \theta_2 \sin \varphi_2, \cos \theta_2)$ are unit vectors, and ρ is the density operator.

56. **subsystem purity** - Consider a system composed of three subsystems labeled by '1', '2' and '3', respectively. The dimensionality of the Hilbert spaces of the three subsystems, which is respectively denoted by N_1 , N_2 and N_3 , is assumed to be finite. Let $\{|n_1\rangle_1\}$, $\{|n_2\rangle_2\}$ and $\{|n_3\rangle_3\}$ be orthonormal bases spanning the Hilbert spaces of subsystems '1', '2' and '3', respectively. The set of vectors $\{|k_1, k_2, k_3\rangle\}$, where $|k_1, k_2, k_3\rangle = |k_1\rangle_1 \otimes |k_2\rangle_2 \otimes |k_3\rangle_3$, forms an orthonormal basis spanning the Hilbert space of the combined system. The system is in a normalized pure state vector $|\psi\rangle$ given by

$$|\psi\rangle = \sum_{k_1=1}^{N_1} \sum_{k_2=1}^{N_2} \sum_{k_3=1}^{N_3} C_{\bar{k}} |\bar{k}\rangle , \quad (8.132)$$

where $\bar{k} = (k_1, k_2, k_3)$, and $C_{\bar{k}}$ are complex numbers. The reduced density operator ρ_{12} of the combined subsystems '1' and '2' is given by $\rho_{12} = \text{Tr}_3(\rho)$, where Tr_3 denotes partial trace over subsystem '3'.

- a) Show that the purity $P_{12} = \text{Tr}(\rho_{12}^2)$ can be expressed as

$$P_{12} = 1 - \langle \mathcal{Q}_{12} \rangle = 1 - \langle \psi | \mathcal{Q}_{12} | \psi \rangle , \quad (8.133)$$

where the operator \mathcal{Q}_{12} can be expressed as

$$\mathcal{Q}_{12} = \sum_{\substack{(k'_1, k'_2) \neq (k''_1, k''_2) \\ k'_3 \neq k''_3}} \frac{P_{(k'_1, k'_2, k'_3), (k'_1, k'_2, k'_3), (k''_1, k''_2, k''_3), (k''_1, k''_2, k''_3)}}{8} , \quad (8.134)$$

where

$$P_{\bar{k}_a, \bar{k}_b, \bar{k}_c, \bar{k}_d} = |\Psi_{\bar{k}_a, \bar{k}_b, \bar{k}_c, \bar{k}_d}\rangle \langle \Psi_{\bar{k}_a, \bar{k}_b, \bar{k}_c, \bar{k}_d}|, \quad (8.135)$$

and where

$$\langle \Psi_{\bar{k}_a, \bar{k}_b, \bar{k}_c, \bar{k}_d}| = C_{\bar{k}_d} \langle \bar{k}_a| + C_{\bar{k}_a} \langle \bar{k}_d| - C_{\bar{k}_c} \langle \bar{k}_b| - C_{\bar{k}_b} \langle \bar{k}_c|. \quad (8.136)$$

- b) As an example, consider a three spin 1/2 system in a pure normalized state $|\psi\rangle$ given by

$$\begin{aligned} |\psi\rangle &= a_{000} |000\rangle + a_{001} |001\rangle + a_{010} |010\rangle + a_{011} |011\rangle \\ &+ a_{100} |100\rangle + a_{101} |101\rangle + a_{110} |110\rangle + a_{111} |111\rangle. \end{aligned} \quad (8.137)$$

The ket vector $|\sigma_3\sigma_2\sigma_1\rangle$, where $\sigma_n \in \{0, 1\}$ and $n \in \{1, 2, 3\}$, represents a state, in which the n 'th spin is pointing in the $\hat{\mathbf{z}}$ ($-\hat{\mathbf{z}}$) direction for $\sigma_n = 1$ ($\sigma_n = 0$). Calculate the purity P_{12} for this case.

- c) **Greenberger Horne Zeilinger state** - Calculate $P_1 = \text{Tr}(\rho_1^2)$ (purity of the first spin) and P_{12} for the state

$$|\psi_{\text{GHZ}}\rangle = \frac{|111\rangle - |000\rangle}{\sqrt{2}}. \quad (8.138)$$

57. Consider a system comprising of two spin 1/2 particles. The system is in a state $|\psi\rangle$ satisfying $\mathbf{S}^2 |\psi\rangle = 0$ and $S_z |\psi\rangle = 0$, where $\mathbf{S} = \mathbf{S}_1 + \mathbf{S}_2$, $S_z = S_{1z} + S_{2z}$ and where \mathbf{S}_1 and \mathbf{S}_2 are the angular momentum vector operators of the first and second spin repetitively, i.e. $\mathbf{S}_1 = (S_{1x}, S_{1y}, S_{1z})$ and $\mathbf{S}_2 = (S_{2x}, S_{2y}, S_{2z})$. A measurement of the observable S_{1z} of the first spin is performed. Given that the result of this measurement is $\hbar/2$, what is the probability p to obtain the result of $\hbar/2$ in a measurement of the observable $\hat{\mathbf{n}} \cdot \mathbf{S}_2$ of the second spin, where $\hat{\mathbf{n}} = (\sin \theta \cos \varphi, \sin \theta \sin \varphi, \cos \theta)$ is a given unit vector, and where both θ and φ are real.
58. Let ρ be the density operator of a given system. The total entropy of the system σ is given by

$$\sigma = -\text{Tr}(\rho \log \rho). \quad (8.139)$$

As in the previous exercise, the system is composed of two subsystems, which are labeled as '1' and '2'. Let $\{|n_1\rangle_1\}$ ($\{|n_2\rangle_2\}$) be an orthonormal basis spanning the Hilbert space of subsystem '1' ('2'). The set of vectors $\{|n_1, n_2\rangle\}$, where $|n_1, n_2\rangle = |n_1\rangle_1 |n_2\rangle_2$, forms an orthonormal basis spanning the Hilbert space of the combined system. The reduced density operators ρ_1 and ρ_2 of subsystems '1' and '2' respectively are giving by

$$\rho_1 = \sum_{n_2} {}_2 \langle n_2 | \rho | n_2 \rangle_2 = \text{Tr}_2 \rho, \quad (8.140)$$

$$\rho_2 = \sum_{n_1} {}_1 \langle n_1 | \rho | n_1 \rangle_1 = \text{Tr}_1 \rho, \quad (8.141)$$

and the subsystems' entropies σ_1 and σ_2 are given by

$$\sigma_1 = -\text{Tr}_1(\rho_1 \log \rho_1) , \quad (8.142)$$

$$\sigma_2 = -\text{Tr}_2(\rho_2 \log \rho_2) . \quad (8.143)$$

Show that

$$\sigma_1 + \sigma_2 \geq \sigma . \quad (8.144)$$

59. **Entropy operator** - The entropy operator S is defined by

$$S = -\log \rho , \quad (8.145)$$

where ρ is the density operator. Calculate the matrix representation of S for a spin 1/2 particle, whose density matrix is given by

$$\rho = \frac{1 + \gamma \hat{\mathbf{n}} \cdot \boldsymbol{\sigma}}{2} , \quad (8.146)$$

where $\boldsymbol{\sigma} = (\sigma_x, \sigma_y, \sigma_z)$ is the Pauli matrix vector, and $\hat{\mathbf{n}}$ is a unit vector, i.e. $\hat{\mathbf{n}} \cdot \hat{\mathbf{n}} = 1$.

60. Consider a spin 1/2 in a magnetic field $\mathbf{B} = B\hat{\mathbf{z}}$ and in thermal equilibrium at temperature T . Calculate the entropy σ , which is defined by

$$\sigma = -\text{Tr}(\rho \log \rho) , \quad (8.147)$$

where ρ is the density operator of the system.

61. A spin 1/2 is in a state $|H\rangle$, which satisfies the following relation

$$|H\rangle \langle H| = \frac{1}{2} \left(\mathbf{1} + \frac{1}{\sqrt{2}} \frac{2(S_x + S_z)}{\hbar} \right) , \quad (8.148)$$

where $\mathbf{1}$ is the identity operator, and where S_x and S_z are spin angular momentum operators. In a measurement of S_z what is the probability p_{z+} to obtain the value $+\hbar/2$?

62. Consider a harmonic oscillator of angular frequency ω and mass m in thermal equilibrium at temperature T . Calculate the entropy σ , which is defined by

$$\sigma = -\text{Tr}(\rho \log \rho) , \quad (8.149)$$

where ρ is the density operator of the system.

63. **Wehrl entropy** - Consider a harmonic oscillator having angular frequency ω . The Wehrl entropy σ_W is defined by

$$\sigma_W = -\int d^2\alpha Q(\alpha) \log(\pi Q(\alpha)) , \quad (8.150)$$

where $Q(\alpha) = \pi^{-1} \langle \alpha | \rho | \alpha \rangle$ is the Husimi function (8.83).

- a) Show that $\sigma_W \geq 0$.
 b) Calculate σ_W for a coherent state $|\alpha\rangle$ [see Eq. (5.35)].
 c) Calculate σ_W for a number state $|n\rangle$ [see Eq. (5.32)].
 d) Calculate σ_W for thermal equilibrium at temperature T .
64. Let \mathcal{H} be a time-independent Hamiltonian of a given system evolving in a finite-dimensional Hilbert space. The system is being measured at the times $t_n = nt/N$, where $n = 0, 1, \dots, N$, where t is the time of the last measurement. In all these measurements the observable is a given projector operator P . Assume that the first measurement at time $t_0 = 0$ yields the value $\sigma_0 = 1$. Evaluate the time evolution of the system from time $t_0 = 0$ to time $t_N = t$ in the limit $N \rightarrow \infty$.
65. Consider a two spin 1/2 system in a pure state $|\psi\rangle$ given by [compare with Eq. (8.123)]

$$|\psi\rangle = a|--\rangle + b|+-\rangle + c|+-\rangle + d|++\rangle . \quad (8.151)$$

The 3×3 spin-spin correlation matrix C is defined by

$$C_{n,m} = \langle \psi | \psi \rangle \langle S_{1n} S_{2m} \rangle - \langle S_{1n} \rangle \langle S_{2m} \rangle , \quad (8.152)$$

where $n, m \in \{x, y, z\}$, and where \mathbf{S}_1 and \mathbf{S}_2 are the angular momentum vector operators of the first and second spin repetitively, i.e. $\mathbf{S}_1 = (S_{1x}, S_{1y}, S_{1z})$ and $\mathbf{S}_2 = (S_{2x}, S_{2y}, S_{2z})$. Show that

$$\tau \equiv \frac{\text{Tr}(C^T C)}{3} = \frac{2|\langle \psi_F | \psi \rangle|^2}{3} \left((\langle \psi | \psi \rangle)^2 + \frac{|\langle \psi_F | \psi \rangle|^2}{2} \right) , \quad (8.153)$$

where $\langle \psi_F | = d\langle -- | - c\langle +- | - b\langle +- | + a\langle ++ |$ [compare with Eq. (8.709)].

66. Consider a three spin 1/2 system in a pure normalized state $|\psi\rangle$ given by

$$\begin{aligned} |\psi\rangle = & q_{000}|000\rangle + q_{001}|001\rangle + q_{010}|010\rangle + q_{011}|011\rangle \\ & + q_{100}|100\rangle + q_{101}|101\rangle + q_{110}|110\rangle + q_{111}|111\rangle . \end{aligned} \quad (8.154)$$

The ket vector $|\eta_c \eta_b \eta_a\rangle$, where $\eta_a, \eta_b, \eta_c \in \{0, 1\}$, represents an eigenvector of the operators $(1 - (2/\hbar) \mathbf{S}_a \cdot \hat{\mathbf{z}})/2$, $(1 - (2/\hbar) \mathbf{S}_b \cdot \hat{\mathbf{z}})/2$ and $(1 - (2/\hbar) \mathbf{S}_c \cdot \hat{\mathbf{z}})/2$ with the eigenvalues η_a , η_b and η_c , respectively, where $\mathbf{S}_a = (S_{ax}, S_{ay}, S_{az})$, $\mathbf{S}_b = (S_{bx}, S_{by}, S_{bz})$ and $\mathbf{S}_c = (S_{cx}, S_{cy}, S_{cz})$ are the angular momentum vector operators of the first (a), second (b) and third (c) spin, respectively. The state vector $|\psi\rangle$ can be represented by a pair \mathcal{P} made of two 2×2 matrices M_0 and M_1

$$\mathcal{P} = (M_0, M_1) , \quad (8.155)$$

where

$$M_0 = \begin{pmatrix} q_{000} & q_{001} \\ q_{010} & q_{011} \end{pmatrix}, \quad (8.156)$$

$$M_1 = \begin{pmatrix} q_{100} & q_{101} \\ q_{110} & q_{111} \end{pmatrix}. \quad (8.157)$$

The matrix M_0 (M_1) represents the 4 terms $q_{\eta_c \eta_b \eta_a}$ in $|\psi\rangle$ (8.154) with $\eta_c = 0$ ($\eta_c = 1$).

- a) Show that the matrix representation of the reduced density operator of the third (c) spin $\rho_c = \text{Tr}_{a,b}(|\psi\rangle\langle\psi|)$ is given by

$$\rho_c \doteq \begin{pmatrix} \text{Tr} \begin{pmatrix} M_0 M_0^\dagger \\ M_0^\dagger M_1 \end{pmatrix} & \text{Tr} \begin{pmatrix} M_0 M_1^\dagger \\ M_1 M_1^\dagger \end{pmatrix} \\ \text{Tr} \begin{pmatrix} M_0^\dagger M_1 \\ M_1^\dagger M_1 \end{pmatrix} & \text{Tr} \begin{pmatrix} M_1 M_1^\dagger \\ M_1^\dagger M_1 \end{pmatrix} \end{pmatrix}. \quad (8.158)$$

- b) Show that

$$\det \rho_c = (V_0 |V_0)(V_1 |V_1) - (V_1 |V_0)(V_0 |V_1), \quad (8.159)$$

where ρ_c is a reduced density operator of the third (c) spin, the column vectors $|V_0\rangle$ and $|V_1\rangle$ are given by

$$|V_0\rangle = \begin{pmatrix} q_{000} \\ q_{001} \\ q_{010} \\ q_{011} \end{pmatrix}, \quad (8.160)$$

$$|V_1\rangle = \begin{pmatrix} q_{100} \\ q_{101} \\ q_{110} \\ q_{111} \end{pmatrix}, \quad (8.161)$$

and the corresponding row vectors $\langle V_0|$ and $\langle V_1|$ are given by

$$\langle V_0| = (q_{000}^* \ q_{001}^* \ q_{010}^* \ q_{011}^*), \quad (8.162)$$

$$\langle V_1| = (q_{100}^* \ q_{101}^* \ q_{110}^* \ q_{111}^*). \quad (8.163)$$

Note that $\det \rho_c = 0$ if and only if spin c is separable from spins a and b, thus this separability occurs according to Eq. (8.159) if and only if the vectors $|V_0\rangle$ and $|V_1\rangle$ are linearly dependent [or, alternatively, the matrices M_0 (8.156) and M_1 (8.157) are linearly dependent].

- c) The state $|\psi_{ABC}\rangle$ is given by $|\psi_{ABC}\rangle = C \otimes B \otimes A |\psi\rangle$, where A , B and C are single spin operators of the first, second and third spin, respectively. Their 2×2 matrix representations are given by

$$A \doteq \begin{pmatrix} a_{11} & a_{12} \\ a_{21} & a_{22} \end{pmatrix}, \quad (8.164)$$

$$B \doteq \begin{pmatrix} b_{11} & b_{12} \\ b_{21} & b_{22} \end{pmatrix}, \quad (8.165)$$

$$C \doteq \begin{pmatrix} c_{11} & c_{12} \\ c_{21} & c_{22} \end{pmatrix}. \quad (8.166)$$

Consider the case

$$C = I \equiv \begin{pmatrix} 1 & 0 \\ 0 & 1 \end{pmatrix}. \quad (8.167)$$

Show that for this case the state $|\psi_{ABC}\rangle$ is represented by the matrix pair \mathcal{P}' [see Eq. (8.155)], which is given by

$$\mathcal{P}' = B\mathcal{P}A^T = (BM_0A^T, BM_1A^T). \quad (8.168)$$

- d) For given single spin operators A and B , the first and second spins correlation function $Q(A, B)$ is given by

$$Q(A, B) = \langle \psi | \psi \rangle \langle \psi | B \otimes A | \psi \rangle - \langle \psi | A | \psi \rangle \langle \psi | B | \psi \rangle. \quad (8.169)$$

Show that

$$Q(A, B) = \text{Tr}(S(I, I) \otimes S(A, B) - S(A, I) \otimes S(I, B)), \quad (8.170)$$

where the 2×2 matrix $S(A, B)$ is given by

$$S(A, B) = M_0^\dagger B M_0 A^T + M_1^\dagger B M_1 A^T, \quad (8.171)$$

and where I is the 2×2 identity matrix.

- e) Assume the case where the Hamiltonian of the system has the form $\mathcal{H} = \mathcal{H}_a + \mathcal{H}_b$, where \mathcal{H}_a and \mathcal{H}_b are Hamiltonians of the first and second spin, respectively (i.e. the spins are all decoupled, and the Hamiltonian of spin c vanishes). Show that the following quantities are all time independent: the reduced density operator $\rho_c = \text{Tr}_{a,b}(|\psi\rangle\langle\psi|)$ [see Eq. (8.158)], and the variables

$$\kappa_0 = q_{000}q_{011} - q_{001}q_{010}, \quad (8.172)$$

$$\kappa_1 = q_{100}q_{111} - q_{101}q_{110}, \quad (8.173)$$

and

$$\kappa_s = q_{000}q_{111} - q_{001}q_{110} - q_{010}q_{101} + q_{011}q_{100}. \quad (8.174)$$

Note that $|\kappa_s|$ is invariant under all three single qubit flips ($\eta_a = 0 \leftrightarrow \eta_a = 1$), ($\eta_b = 0 \leftrightarrow \eta_b = 1$) and ($\eta_c = 0 \leftrightarrow \eta_c = 1$).

- f) The partial entanglement between the first (a) and second (b) spins is quantified by the variable $\tau_{a,b}$, which is given by

$$\tau_{a,b}(|\psi\rangle) = \frac{\text{Tr}(\mu^T \mu)}{3}, \quad (8.175)$$

where the 3×3 matrix μ is given by [see Eq. (8.169)]

$$\mu = \begin{pmatrix} Q(\sigma_1, \sigma_1) & Q(\sigma_1, \sigma_2) & Q(\sigma_1, \sigma_3) \\ Q(\sigma_2, \sigma_1) & Q(\sigma_2, \sigma_2) & Q(\sigma_2, \sigma_3) \\ Q(\sigma_3, \sigma_1) & Q(\sigma_3, \sigma_2) & Q(\sigma_3, \sigma_3) \end{pmatrix}, \quad (8.176)$$

and σ_1, σ_2 and σ_3 are the Pauli matrices (6.137). Show that $\tau_{a,b}$ is time independent, provided that $\mathcal{H} = \mathcal{H}_a + \mathcal{H}_b$.

g) show that for the two-spin Bell singlet state [see Eq. (8.124)]

$$\tau_{a,b} \left(\frac{|000\rangle - |011\rangle}{\sqrt{2}} \right) = 1, \quad (8.177)$$

for the three-spin GHZ state [see Eq. (8.138)]

$$\tau_{a,b} \left(\frac{|111\rangle - |000\rangle}{\sqrt{2}} \right) = \frac{1}{3}, \quad (8.178)$$

and for the state $|000\rangle$

$$\tau_{a,b}(|000\rangle) = 0. \quad (8.179)$$

Note that generally, τ is bounded by $0 \leq \tau \leq 1$.

67. **Generalized Gell-Mann matrices** - Consider a d_H -dimensional Hilbert space, where $d_H \in \{2, 3, \dots\}$ is finite. The set $\{\lambda_a\}$ of generalized Gell-Mann matrices contains $d_H^2 - 1$ square $d_H \times d_H$ Hermitian matrices. The set $\{\lambda_a\}$ can be divided into three subsets. The subset $\{\lambda_{X,(n,m)}\}$ contains $d_H(d_H - 1)/2$ matrices given by $\lambda_{X,(n,m)} = |n\rangle(m| + |m\rangle(n|$, and the subset $\{\lambda_{Y,(n,m)}\}$ contains $d_H(d_H - 1)/2$ matrices given by $\lambda_{Y,(n,m)} = -i|n\rangle(m| + i|m\rangle(n|$, where $1 \leq m < n \leq d_H$, and where $|k'\rangle\langle k''|$ denotes a $d_H \times d_H$ matrix having entry 1 in the k' row - k'' column, and entry 0 elsewhere. The subset $\{\lambda_{Z,l}\}$ contains $d_H - 1$ diagonal matrices given by

$$\lambda_{Z,l} = \sqrt{\frac{2}{l(l+1)}} \left(-l|l+1\rangle\langle l+1| + \sum_{j=1}^l |j\rangle\langle j| \right), \quad (8.180)$$

where $1 \leq l \leq d_H - 1$. For the case $d_H = 2$ ($d_H = 3$) the matrices are called Pauli (Gell-Mann) matrices, and they are called Generalized Gell-Mann matrices for $d_H \geq 4$. The Generalized Gell-Mann matrices are traceless, i.e. $\text{Tr} \lambda_a = 0$, and they satisfy the orthogonality relation

$$\frac{\text{Tr}(\lambda_a \lambda_b)}{2} = \delta_{ab}. \quad (8.181)$$

The set $\{\lambda_a\}$ spans the $SU(d_H)$ Lie algebra.

a) Write explicitly the set $\{\lambda_a\}$ for the case $d_H = 3$ (the set of Gell-Mann matrices).

b) **completeness relation** - Show that

$$\sum_{a=1}^{d_{\text{H}}^2-1} (\lambda_a)_{n',n''} (\lambda_a)_{n''',n''''} = 2 \left(\delta_{n',n''''} \delta_{n'',n'''} - \frac{\delta_{n',n''} \delta_{n''',n''''}}{d_{\text{H}}} \right). \quad (8.182)$$

c) **generalized Bloch vector** - The density matrix ρ is expanded as

$$\rho = \frac{\lambda_0}{d_{\text{H}}} + \frac{\sum_{a=1}^{d_{\text{H}}^2-1} k_a \lambda_a}{2}, \quad (8.183)$$

where $\lambda_0 = \sum_{k=1}^{d_{\text{H}}} |k\rangle \langle k|$ is the $d_{\text{H}} \times d_{\text{H}}$ identity matrix. Show that the length of the generalized Bloch vector $\vec{k} = (k_1, k_2, \dots, k_{d_{\text{H}}^2-1})$ is a constant of the motion, when ρ evolves in time according to Eq. (8.29), which reads $d\rho/dt = i\hbar^{-1} [\rho, \mathcal{H}]$, where \mathcal{H} is the Hamiltonian.

d) Consider a unitary transformation

$$\rho \rightarrow \rho' = U\rho U^\dagger, \quad (8.184)$$

where $UU^\dagger = U^\dagger U = 1$. The $(d_{\text{H}}^2 - 1) \times (d_{\text{H}}^2 - 1)$ matrix S is defined by

$$k'_b = \sum_{a=1}^{d_{\text{H}}^2-1} S_{ba} k_a, \quad (8.185)$$

where $k'_b = \text{Tr}(\rho' \lambda_b)$. Show that S is an orthonormal matrix, i.e.

$$\sum_{a=1}^{d_{\text{H}}^2-1} S_{ab'} S_{ab''} = \delta_{b',b''}, \quad (8.186)$$

$$\sum_{a=1}^{d_{\text{H}}^2-1} S_{b'a} S_{b''a} = \delta_{b',b''}. \quad (8.187)$$

8.5 Solutions

1. Let $\{|a_n\rangle\}$ be an orthonormal and complete basis. The following holds

$$\begin{aligned} (\text{Tr}(AB))^* &= \sum_n \langle a_n | AB | a_n \rangle^* \\ &= \sum_n \langle a_n | (AB)^\dagger | a_n \rangle, \end{aligned} \quad (8.188)$$

and thus, with the help of Eqs. (2.47) and (2.134) and the relations $A^\dagger = A$ and $B^\dagger = B$ one finds that

$$\begin{aligned} (\text{Tr}(AB))^* &= \sum_n \langle a_n | B^\dagger A^\dagger | a_n \rangle \\ &= \sum_n \langle a_n | AB | a_n \rangle \\ &= \text{Tr}(AB) , \end{aligned} \tag{8.189}$$

and therefore $\text{Tr}(AB)$ is real.

2. The following holds

$$\begin{aligned} \text{Tr} \rho^2 &= \lambda^2 \text{Tr}(\rho_1^2) + (1-\lambda)^2 \text{Tr}(\rho_2^2) + \lambda(1-\lambda) \text{Tr}(\rho_1 \rho_2 + \rho_2 \rho_1) \\ &= \lambda^2 + (1-\lambda)^2 + 2\lambda(1-\lambda) \text{Tr}(\rho_1 \rho_2) \\ &= 1 - 2\lambda(1-\lambda)(1 - \text{Tr}(\rho_1 \rho_2)) \\ &= 1 - 2\lambda(1-\lambda) \left(1 - |\langle \psi_1 | \psi_2 \rangle|^2\right) , \end{aligned}$$

and $0 < 2\lambda(1-\lambda) < 1/2$ for $0 < \lambda < 1$, hence $\text{Tr} \rho^2 = 1$ (i.e. ρ is pure) if and only if $|\langle \psi_1 | \psi_2 \rangle| = 1$.

3. The Hamiltonian is given by

$$\mathcal{H} = \omega S_z , \tag{8.190}$$

where

$$\omega = \frac{|e|B}{m_e c} \tag{8.191}$$

is the Larmor frequency. In the basis of the eigenvectors of S_z

$$S_z |\pm\rangle = \pm \frac{\hbar}{2} |\pm\rangle , \tag{8.192}$$

one has

$$\mathcal{H} |\pm\rangle = \pm \frac{\hbar\omega}{2} |\pm\rangle , \tag{8.193}$$

thus

$$\begin{aligned} \rho &= \frac{e^{-\mathcal{H}\beta}}{\text{Tr}(e^{-\mathcal{H}\beta})} \\ &= \frac{e^{-\frac{\hbar\omega\beta}{2}} |+\rangle \langle +| + e^{\frac{\hbar\omega\beta}{2}} |-\rangle \langle -|}{e^{-\frac{\hbar\omega\beta}{2}} + e^{\frac{\hbar\omega\beta}{2}}} , \end{aligned} \tag{8.194}$$

where $\beta = 1/(k_{\text{B}}T)$, and therefore with the help of Eqs. (2.103) and (2.104), which are given by

$$S_x = \frac{\hbar}{2} (|+\rangle \langle -| + |- \rangle \langle +|) , \quad (8.195)$$

$$S_y = \frac{\hbar}{2} (-i |+\rangle \langle -| + i |- \rangle \langle +|) , \quad (8.196)$$

one has

$$\langle S_x \rangle = \text{Tr}(\rho S_x) = 0 , \quad (8.197)$$

$$\langle S_y \rangle = \text{Tr}(\rho S_y) = 0 , \quad (8.198)$$

and with the help of Eq. (2.100), which is given by

$$S_z = \frac{\hbar}{2} (|+\rangle \langle +| - |- \rangle \langle -|) , \quad (8.199)$$

one has

$$\begin{aligned} \langle S_z \rangle &= \text{Tr}(\rho S_z) \\ &= \text{Tr} \left(\frac{e^{-\frac{\hbar\omega\beta}{2}} |+\rangle \langle +| + e^{\frac{\hbar\omega\beta}{2}} |- \rangle \langle -|}{e^{-\frac{\hbar\omega\beta}{2}} + e^{\frac{\hbar\omega\beta}{2}}} \frac{\hbar}{2} (|+\rangle \langle +| - |- \rangle \langle -|) \right) \\ &= \frac{\hbar}{2} \frac{e^{-\frac{\hbar\omega\beta}{2}} - e^{\frac{\hbar\omega\beta}{2}}}{e^{-\frac{\hbar\omega\beta}{2}} + e^{\frac{\hbar\omega\beta}{2}}} \\ &= -\frac{\hbar}{2} \tanh \left(\frac{\hbar\omega\beta}{2} \right) , \end{aligned} \quad (8.200)$$

thus

$$\langle \mathbf{S} \cdot \hat{\mathbf{u}} \rangle = -\frac{\hbar \cos \theta}{2} \tanh \left(\frac{\hbar\omega\beta}{2} \right) . \quad (8.201)$$

4. Recall that

$$|\pm; \hat{\mathbf{y}}\rangle = \frac{1}{\sqrt{2}} (|+\rangle \pm i |- \rangle) , \quad (8.202)$$

a) thus

$$\rho \doteq \frac{1}{2} \begin{pmatrix} 1 \\ i \end{pmatrix} (1 - i) = \frac{1}{2} \begin{pmatrix} 1 & -i \\ i & 1 \end{pmatrix} . \quad (8.203)$$

b) For a pure state $\rho^n = \rho$.

c) For this case

$$\rho = \frac{1}{2} \left(\underbrace{|\pm; \hat{\mathbf{y}}\rangle \langle +; \hat{\mathbf{y}}| + |-; \hat{\mathbf{y}}\rangle \langle -; \hat{\mathbf{y}}|}_{=1} \right) \doteq \frac{1}{2} \begin{pmatrix} 1 & 0 \\ 0 & 1 \end{pmatrix} , \quad (8.204)$$

d) and

$$\rho^n \doteq \frac{1}{2^n} \begin{pmatrix} 1 & 0 \\ 0 & 1 \end{pmatrix}. \quad (8.205)$$

5. The state at time $t = 0$ is given by

$$|\psi(t=0)\rangle \doteq \begin{pmatrix} \cos \frac{\theta}{2} \\ \sin \frac{\theta}{2} \end{pmatrix}, \quad (8.206)$$

and the one at time $t = T$ is

$$|\psi(t=T)\rangle = \exp\left(\frac{i\omega T \sigma_x}{2}\right) |\psi(t=0)\rangle, \quad (8.207)$$

where σ_x is a Pauli matrix, and

$$\omega = \frac{eB}{m_e c}. \quad (8.208)$$

Using the identity

$$\exp\left(-\frac{i\boldsymbol{\sigma} \cdot \hat{\mathbf{n}}\phi}{2}\right) = \cos \frac{\phi}{2} - i\boldsymbol{\sigma} \cdot \hat{\mathbf{n}} \sin \frac{\phi}{2}, \quad (8.209)$$

one finds

$$\exp\left(-\frac{i\boldsymbol{\sigma} \cdot \hat{\mathbf{n}}\phi}{2}\right) = \cos \frac{\omega T}{2} + i\sigma_x \sin \frac{\omega T}{2} \doteq \begin{pmatrix} \cos \frac{\omega T}{2} & i \sin \frac{\omega T}{2} \\ i \sin \frac{\omega T}{2} & \cos \frac{\omega T}{2} \end{pmatrix}, \quad (8.210)$$

thus

$$\begin{aligned} |\psi(t=T)\rangle &\doteq \begin{pmatrix} \cos \frac{\omega T}{2} & i \sin \frac{\omega T}{2} \\ i \sin \frac{\omega T}{2} & \cos \frac{\omega T}{2} \end{pmatrix} \begin{pmatrix} \cos \frac{\theta}{2} \\ \sin \frac{\theta}{2} \end{pmatrix} \\ &= \begin{pmatrix} \cos \frac{\omega T}{2} \cos \frac{\theta}{2} + i \sin \frac{\omega T}{2} \sin \frac{\theta}{2} \\ i \sin \frac{\omega T}{2} \cos \frac{\theta}{2} + \cos \frac{\omega T}{2} \sin \frac{\theta}{2} \end{pmatrix}. \end{aligned} \quad (8.211)$$

a) The probabilities to measured $\pm \hbar/2$ are thus given by

$$\begin{aligned} P_+ &= \cos^2 \frac{\omega T}{2} \cos^2 \frac{\theta}{2} + \sin^2 \frac{\omega T}{2} \sin^2 \frac{\theta}{2} \\ &= \frac{1 + \cos(\omega T) \cos \theta}{2}, \end{aligned} \quad (8.212)$$

and

$$\begin{aligned} P_- &= \cos^2 \frac{\omega T}{2} \sin^2 \frac{\theta}{2} + \sin^2 \frac{\omega T}{2} \cos^2 \frac{\theta}{2} \\ &= \frac{1 - \cos(\omega T) \cos \theta}{2}. \end{aligned} \quad (8.213)$$

b) The density operator is given by

$$\rho_{11} = P_+ ,$$

$$\rho_{22} = P_- ,$$

$$\begin{aligned} \rho_{21} &= \left(\cos \frac{\omega T}{2} \cos \frac{\theta}{2} + i \sin \frac{\omega T}{2} \sin \frac{\theta}{2} \right) \left(-i \sin \frac{\omega T}{2} \cos \frac{\theta}{2} + \cos \frac{\omega T}{2} \sin \frac{\theta}{2} \right) \\ &= \frac{\sin \theta}{2} - \frac{i}{2} \sin \omega T \cos \theta , \end{aligned}$$

$$\rho_{12} = \rho_{21}^* .$$

6. The Hamiltonian is given by

$$H = -\omega S_z , \quad (8.214)$$

where

$$\omega = \frac{eB}{m_e c} , \quad (8.215)$$

thus, the density operator is given by

$$\rho = \frac{1}{Z} \begin{pmatrix} \exp\left(\frac{\hbar\omega}{2k_B T}\right) & 0 \\ 0 & \exp\left(-\frac{\hbar\omega}{2k_B T}\right) \end{pmatrix} , \quad (8.216)$$

where

$$Z = \exp\left(\frac{\hbar\omega}{2k_B T}\right) + \exp\left(-\frac{\hbar\omega}{2k_B T}\right) . \quad (8.217)$$

a) Using

$$S_z(t) = \exp\left(\frac{iHt}{\hbar}\right) S_z(0) \exp\left(-\frac{iHt}{\hbar}\right) = S_z(0) , \quad (8.218)$$

one finds

$$C_z(t) = \langle S_z^2(0) \rangle = \text{Tr}(\rho S_z^2(0)) = \frac{\hbar^2}{4} . \quad (8.219)$$

b) The following holds

$$\begin{aligned} S_x(t) &= \exp\left(-\frac{i\omega S_z t}{\hbar}\right) S_x(0) \exp\left(\frac{i\omega S_z t}{\hbar}\right) \\ &= S_x \cos(\omega t) + S_y \sin(\omega t) , \end{aligned} \quad (8.220)$$

thus

$$\begin{aligned} C_x(t) &= \cos(\omega t) \langle S_x^2(0) \rangle + \sin(\omega t) \langle S_y(0) S_x(0) \rangle \\ &= \frac{\cos(\omega t) \hbar^2}{4} + \sin(\omega t) \langle S_y(0) S_x(0) \rangle . \end{aligned} \quad (8.221)$$

In terms of Pauli matrices

$$\begin{aligned}
 \langle S_y(0) S_x(0) \rangle &= \frac{\hbar^2}{4Z} \text{Tr} \left(\begin{pmatrix} \exp\left(\frac{\hbar\omega}{2k_B T}\right) & 0 \\ 0 & \exp\left(-\frac{\hbar\omega}{2k_B T}\right) \end{pmatrix} \begin{pmatrix} 0 & -i \\ i & 0 \end{pmatrix} \begin{pmatrix} 0 & 1 \\ 1 & 0 \end{pmatrix} \right) \\
 &= \frac{\hbar^2}{4Z} \text{Tr} \left(\begin{pmatrix} -i \exp\left(\frac{\hbar\omega}{2k_B T}\right) & 0 \\ 0 & i \exp\left(-\frac{\hbar\omega}{2k_B T}\right) \end{pmatrix} \right) \\
 &= -\frac{i\hbar^2}{4} \tanh\left(\frac{\hbar\omega}{2k_B T}\right),
 \end{aligned} \tag{8.222}$$

thus

$$C_x(t) = \frac{\hbar^2}{4} \left[\cos(\omega t) - i \sin(\omega t) \tanh\left(\frac{\hbar\omega}{2k_B T}\right) \right]. \tag{8.223}$$

7. A general 2×2 Hermitian density matrix which satisfies the requirement $\text{Tr}(\rho) = 1$ can be expressed as

$$\rho = \begin{pmatrix} p & z \\ z^* & 1-p \end{pmatrix}, \tag{8.224}$$

where p is real and z is complex. The requirements [see Eq. (6.137)]

$$\langle \sigma_x \rangle = \text{Tr}(\rho \sigma_x) = z + z^*, \tag{8.225}$$

$$\langle \sigma_y \rangle = \text{Tr}(\rho \sigma_y) = i(z - z^*), \tag{8.226}$$

$$\langle \sigma_z \rangle = \text{Tr}(\rho \sigma_z) = 2p - 1, \tag{8.227}$$

yield

$$\rho = \frac{1}{2} \begin{pmatrix} 1 + \langle \sigma_z \rangle & \langle \sigma_x \rangle - i \langle \sigma_y \rangle \\ \langle \sigma_x \rangle + i \langle \sigma_y \rangle & 1 - \langle \sigma_z \rangle \end{pmatrix}, \tag{8.228}$$

or

$$\rho = \frac{1}{2} (1 + \langle \sigma_x \rangle \sigma_x + \langle \sigma_y \rangle \sigma_y + \langle \sigma_z \rangle \sigma_z). \tag{8.229}$$

8. Clearly, $0 \leq \langle \beta | \rho | \beta \rangle$ since

$$\langle \beta | \rho | \beta \rangle = \sum_i w_i \langle \beta | \alpha^{(i)} \rangle \langle \alpha^{(i)} | \beta \rangle = \sum_i w_i \left| \langle \alpha^{(i)} | \beta \rangle \right|^2 \geq 0. \tag{8.230}$$

On the other hand, according to the Schwartz inequality [which is given by $|\langle u | v \rangle| \leq \sqrt{\langle u | u \rangle} \sqrt{\langle v | v \rangle}$, see Eq. (2.172)] one has

$$\left| \langle \alpha^{(i)} | \beta \rangle \right| \leq \sqrt{\langle \beta | \beta \rangle} \sqrt{\langle \alpha^{(i)} | \alpha^{(i)} \rangle} = 1. \tag{8.231}$$

hence [see Eq. (8.8)]

$$\langle \beta | \rho | \beta \rangle = \sum_i w_i \left| \langle \alpha^{(i)} | \beta \rangle \right|^2 \leq 1. \tag{8.232}$$

9. The assumption that ρ represents a pure state implies that it can be expressed as

$$\rho = |\alpha\rangle \langle\alpha| , \quad (8.233)$$

where $|\alpha\rangle$ is a normalized state. For every normalized state $|\beta\rangle$ that is orthogonal to $|\alpha\rangle$, i.e. $\langle\beta|\alpha\rangle = 0$, the following holds

$$0 = \langle\beta|\rho|\beta\rangle = \eta \langle\beta|\rho_1|\beta\rangle + (1 - \eta) \langle\beta|\rho_2|\beta\rangle . \quad (8.234)$$

Since both η and $1 - \eta$ are positive, this implies that [recall inequality (8.44)]

$$0 = \langle\beta|\rho_1|\beta\rangle = \langle\beta|\rho_2|\beta\rangle . \quad (8.235)$$

Let $\rho_{s,n,m}$ be the matrix elements of the operator ρ_s , where $s \in \{1, 2\}$, in a given orthonormal basis, and assume that the first vector of the basis is taken to be the vector $|\alpha\rangle$. In general

$$\text{Tr}(\rho_s) = \sum_n \rho_{s,n,n} , \quad (8.236)$$

$$\text{Tr}(\rho_s^2) = \sum_{n,m} |\rho_{s,n,n}|^2 . \quad (8.237)$$

The requirement $\text{Tr}(\rho_s) = 1$ together with Eqs. (8.235) and (8.236) imply that

$$\rho_{s,1,1} = \langle\alpha|\rho_s|\alpha\rangle = 1 . \quad (8.238)$$

The requirement $\text{Tr}(\rho_n^2) \leq 1$ together with Eqs. (8.237) and (8.238) imply that $\rho_{s,n,m} = 0$ unless $n = m = 1$, and thus $\rho_1 = \rho_2 = \rho$.

10. The variance ΔN is given by

a) For an energy eigenstate $|n\rangle$ one has

$$N |n\rangle = n |n\rangle , \quad (8.239)$$

thus

$$\langle N \rangle = \langle n | N | n \rangle = n , \quad (8.240)$$

and

$$\langle N^2 \rangle = \langle n | N^2 | n \rangle = n^2 , \quad (8.241)$$

therefore

$$\Delta N = 0 . \quad (8.242)$$

b) For a coherent state $|\alpha\rangle$ one has

$$a|\alpha\rangle = \alpha|\alpha\rangle, \quad (8.243)$$

thus

$$\langle N \rangle = \langle \alpha | N | \alpha \rangle = \langle \alpha | a^\dagger a | \alpha \rangle = |\alpha|^2, \quad (8.244)$$

and

$$\langle N^2 \rangle = \langle \alpha | a^\dagger a a^\dagger a | \alpha \rangle = \langle \alpha | a^\dagger \left(\underbrace{[a, a^\dagger]}_{=1} + a^\dagger a \right) a | \alpha \rangle = |\alpha|^2 + |\alpha|^4, \quad (8.245)$$

therefore

$$\Delta N = \sqrt{\langle N^2 \rangle}. \quad (8.246)$$

c) In general, for a thermal state one has

$$\langle O \rangle = \text{Tr}(\rho O), \quad (8.247)$$

where O is an operator,

$$\rho = \frac{1}{Z} e^{-\mathcal{H}\beta}, \quad (8.248)$$

$$Z = \text{Tr}(e^{-\mathcal{H}\beta}), \quad (8.249)$$

and $\beta = 1/(k_B T)$ and \mathcal{H} is the Hamiltonian. For the present case

$$\mathcal{H} = \hbar\omega \left(N + \frac{1}{2} \right), \quad (8.250)$$

thus

$$\begin{aligned} \langle N \rangle &= \text{Tr}(\rho N) \\ &= \frac{\sum_{n=0}^{\infty} \langle n | e^{-\mathcal{H}\beta} N | n \rangle}{\sum_{n=0}^{\infty} \langle n | e^{-\mathcal{H}\beta} | n \rangle} \\ &= \frac{\sum_{n=0}^{\infty} n e^{-n\hbar\omega\beta}}{\sum_{n=0}^{\infty} e^{-n\hbar\omega\beta}} \\ &= -\frac{1}{\hbar\omega} \frac{\partial \log \left(\sum_{n=0}^{\infty} e^{-n\hbar\omega\beta} \right)}{\partial \beta} \\ &= \frac{e^{-\beta\hbar\omega}}{1 - e^{-\beta\hbar\omega}}, \end{aligned} \quad (8.251)$$

and

$$\begin{aligned}
\langle N^2 \rangle &= \text{Tr}(\rho N^2) \\
&= \frac{\sum_{n=0}^{\infty} \langle n | e^{-\mathcal{H}\beta} N^2 | n \rangle}{\sum_{n=0}^{\infty} \langle n | e^{-\mathcal{H}\beta} | n \rangle} \\
&= \frac{\sum_{n=0}^{\infty} n^2 e^{-n\hbar\omega\beta}}{\sum_{n=0}^{\infty} e^{-n\hbar\omega\beta}} \\
&= \frac{\left(\frac{1}{\hbar\omega}\right)^2 \frac{\partial^2}{\partial\beta^2} \sum_{n=0}^{\infty} e^{-n\hbar\omega\beta}}{\sum_{n=0}^{\infty} e^{-n\hbar\omega\beta}} \\
&= \frac{(e^{-\beta\hbar\omega} + 1) e^{-\beta\hbar\omega}}{(1 - e^{-\beta\hbar\omega})^2},
\end{aligned} \tag{8.252}$$

and therefore

$$(\Delta N)^2 = \langle N^2 \rangle - \langle N \rangle^2 = \frac{e^{-\beta\hbar\omega}}{(1 - e^{-\beta\hbar\omega})^2} = \langle N \rangle (\langle N \rangle + 1). \tag{8.253}$$

11. The density operator is given by

$$\rho = \frac{1}{Z} e^{-\mathcal{H}\beta}. \tag{8.254}$$

where

$$Z = \text{tr}(e^{-\mathcal{H}\beta}) = \sum_{n=0}^{\infty} e^{-\beta\hbar\omega(n+\frac{1}{2})} = \frac{e^{-\frac{\beta\hbar\omega}{2}}}{1 - e^{-\beta\hbar\omega}} = \frac{1}{2 \sinh\left(\frac{\hbar\omega\beta}{2}\right)}, \tag{8.255}$$

and $\beta = 1/(k_{\text{B}}T)$. Thus using

$$x^2 = \frac{\hbar}{2m\omega} \left(a^2 + (a^\dagger)^2 + 2a^\dagger a + 1 \right), \tag{8.256}$$

one finds

$$\begin{aligned}
\langle x^2 \rangle &= \text{Tr} (x^2 \rho) \\
&= \frac{1}{Z} \sum_{n=0}^{\infty} \langle n | x^2 e^{-H\beta} | n \rangle \\
&= \frac{1}{Z} \sum_{n=0}^{\infty} e^{-\hbar\omega(n+\frac{1}{2})\beta} \langle n | x^2 | n \rangle \\
&= \frac{\hbar}{m\omega} \frac{1}{Z} \sum_{n=0}^{\infty} \left(n + \frac{1}{2} \right) e^{-\hbar\omega(n+\frac{1}{2})\beta} \\
&= \frac{\hbar}{m\omega} \frac{1}{Z} \left(-\frac{1}{\hbar\omega} \right) \frac{d}{d\beta} \sum_{n=0}^{\infty} e^{-\hbar\omega(n+\frac{1}{2})\beta} .
\end{aligned} \tag{8.257}$$

However

$$\sum_{n=0}^{\infty} e^{-\hbar\omega(n+\frac{1}{2})\beta} = Z , \tag{8.258}$$

thus

$$\begin{aligned}
\langle x^2 \rangle &= \frac{1}{m\omega^2} \frac{d}{d\beta} \log Z^{-1} \\
&= \frac{1}{m\omega^2} \frac{\frac{d}{d\beta} \sinh\left(\frac{\hbar\omega\beta}{2}\right)}{\sinh\left(\frac{\hbar\omega\beta}{2}\right)} \\
&= \frac{1}{m\omega^2} \frac{\hbar\omega}{2} \coth\left(\frac{\hbar\omega\beta}{2}\right) .
\end{aligned} \tag{8.259}$$

Note that at high temperatures $\hbar\omega\beta \ll 1$

$$\langle x^2 \rangle \simeq \frac{k_B T}{m\omega^2} , \tag{8.260}$$

as is required by the equipartition theorem of classical statistical mechanics.

12. The eigenenergy values are $E_k = \hbar\omega (2k + 3/2)$ where $k = 0, 1, 2, \dots$, and the expectation value of $\langle x^2 \rangle$ for the k' th state is $\langle x^2 \rangle_k = (\hbar/m\omega) (2k + 3/2)$ [see Eq. (5.177)], thus

$$\begin{aligned}
\langle x^2 \rangle &= \frac{\sum_{k=0}^{\infty} \langle x^2 \rangle_k \exp(-\beta E_k)}{\sum_{k=0}^{\infty} \exp(-\beta E_k)} \\
&= \frac{\hbar}{m\omega} \frac{\sum_{k=0}^{\infty} (2k + \frac{3}{2}) \exp(-\beta \hbar \omega (2k + \frac{3}{2}))}{\sum_{k=0}^{\infty} \exp(-\beta \hbar \omega (2k + \frac{3}{2}))} \\
&= \frac{\hbar}{m\omega} \left(\frac{3}{2} + \frac{2}{e^{2\beta \hbar \omega} - 1} \right),
\end{aligned} \tag{8.261}$$

where $\beta = 1/(k_B T)$.

13. In the basis of number states the density operator is given by

$$\begin{aligned}
\rho &= \frac{e^{-\mathcal{H}\beta}}{\text{Tr}(e^{-\mathcal{H}\beta})} = \frac{\sum_{n=0}^{\infty} e^{-\mathcal{H}\beta} |n\rangle \langle n|}{\sum_{n=0}^{\infty} \langle n| e^{-\mathcal{H}\beta} |n\rangle} \\
&= \frac{\sum_{n=0}^{\infty} e^{-\beta \hbar \omega (N + \frac{1}{2})} |n\rangle \langle n|}{\sum_{n=0}^{\infty} \langle n| e^{-\beta \hbar \omega (N + \frac{1}{2})} |n\rangle} \\
&= \frac{\sum_{n=0}^{\infty} e^{-n\beta \hbar \omega} |n\rangle \langle n|}{\sum_{n=0}^{\infty} e^{-n\beta \hbar \omega}} \\
&= (1 - e^{-\beta \hbar \omega}) \sum_{n=0}^{\infty} e^{-n\beta \hbar \omega} |n\rangle \langle n|,
\end{aligned} \tag{8.262}$$

where $\beta = 1/(k_B T)$. Thus, $\langle N \rangle$ is given by

$$\begin{aligned}
\langle N \rangle &= \text{Tr}(\rho N) \\
&= (1 - e^{-\beta \hbar \omega}) \sum_{n=0}^{\infty} n e^{-n\beta \hbar \omega} \\
&= -\hbar \omega (1 - e^{-\beta \hbar \omega}) \frac{\partial}{\partial \beta} \sum_{n=0}^{\infty} e^{-n\beta \hbar \omega} \\
&= -\hbar \omega (1 - e^{-\beta \hbar \omega}) \frac{\partial}{\partial \beta} \frac{1}{1 - e^{-\beta \hbar \omega}} \\
&= \frac{e^{-\beta \hbar \omega}}{1 - e^{-\beta \hbar \omega}}.
\end{aligned} \tag{8.263}$$

Moreover, the following holds

$$\langle N \rangle + 1 = \frac{1}{1 - e^{-\beta\hbar\omega}}, \quad (8.264)$$

$$\frac{\langle N \rangle}{\langle N \rangle + 1} = e^{-\beta\hbar\omega}, \quad (8.265)$$

thus, ρ can be rewritten as

$$\begin{aligned} \rho &= (1 - e^{-\beta\hbar\omega}) \sum_{n=0}^{\infty} e^{-n\beta\hbar\omega} |n\rangle \langle n| \\ &= \frac{1}{\langle N \rangle + 1} \sum_{n=0}^{\infty} \left(\frac{\langle N \rangle}{\langle N \rangle + 1} \right)^n |n\rangle \langle n|. \end{aligned} \quad (8.266)$$

To verify the validity of Eq. (8.50) we calculate

$$\langle n | \rho | m \rangle = \int \int d^2\alpha P(\alpha) \langle n | \alpha \rangle \langle \alpha | m \rangle. \quad (8.267)$$

With the help of Eq. (5.42), which is given by

$$|\alpha\rangle = e^{-\frac{|\alpha|^2}{2}} \sum_{n=0}^{\infty} \frac{\alpha^n}{\sqrt{n!}} |n\rangle, \quad (8.268)$$

one finds that

$$\langle n | \rho | m \rangle = \frac{1}{\pi \langle N \rangle} \int \int d^2\alpha \exp\left(-\frac{|\alpha|^2}{\langle N \rangle}\right) e^{-|\alpha|^2} \frac{\alpha^n}{\sqrt{n!}} \frac{\alpha^{*m}}{\sqrt{m!}}. \quad (8.269)$$

Employing polar coordinates in the complex plane $\alpha = r e^{i\theta}$, where r is non-negative real and θ is real,

$$\begin{aligned} \langle n | \rho | m \rangle &= \frac{1}{\pi \langle N \rangle \sqrt{n!m!}} \int_0^{\infty} dr e^{-(1+\frac{1}{\langle N \rangle})r^2} r^{n+m+1} \underbrace{\int_0^{2\pi} d\theta e^{i\theta(n-m)}}_{2\pi\delta_{nm}} \\ &= \frac{2\delta_{nm}}{\langle N \rangle n!} \int_0^{\infty} dr e^{-(1+\frac{1}{\langle N \rangle})r^2} r^{2n+1}, \end{aligned} \quad (8.270)$$

and the transformation of the integration variable

$$t = \left(1 + \frac{1}{\langle N \rangle}\right) r^2, \quad (8.271)$$

$$dt = \left(1 + \frac{1}{\langle N \rangle}\right) 2r dr, \quad (8.272)$$

lead to

$$\begin{aligned}
 \langle n | \rho | m \rangle &= \frac{\delta_{nm}}{\langle N \rangle \left(1 + \frac{1}{\langle N \rangle}\right)^{n+1}} \underbrace{\int_0^\infty dt e^{-t} t^n}_{\Gamma(n+1)=n!} \\
 &= \frac{\delta_{nm}}{\langle N \rangle \left(1 + \frac{1}{\langle N \rangle}\right)^{n+1}} \\
 &= \frac{\langle N \rangle^n \delta_{nm}}{(1 + \langle N \rangle)^{n+1}},
 \end{aligned} \tag{8.273}$$

in agreement with Eq. (8.266).

14. The density operator [see Eq. (8.50)] is given by

$$\rho = \int \int d^2\alpha |\alpha\rangle \langle \alpha| P(\alpha), \tag{8.274}$$

where $|\alpha\rangle$ is a coherent state, $d^2\alpha$ denotes infinitesimal area in the α complex plane,

$$P(\alpha) = \frac{1}{\pi \langle N \rangle} \exp\left(-\frac{|\alpha|^2}{\langle N \rangle}\right), \tag{8.275}$$

and where

$$\langle N \rangle = \frac{e^{-\beta\hbar\omega}}{1 - e^{-\beta\hbar\omega}} \tag{8.276}$$

is the expectation value of the number operator N . Thus,

$$f(x') = \langle x' | \rho | x' \rangle = \int \int d^2\alpha P(\alpha) \langle x' | \alpha \rangle \langle \alpha | x' \rangle.$$

By employing the expression for the wave function $\psi_\alpha(x') = \langle x' | \alpha \rangle$ of a coherent state which is given by [see Eq. (5.51)]

$$\begin{aligned}
 \psi_\alpha(x') &= \langle x' | \alpha \rangle \\
 &= \exp\left(\frac{\alpha^* x' - \alpha x'^2}{4}\right) \left(\frac{m\omega}{\pi\hbar}\right)^{1/4} \exp\left[-\left(\frac{x' - \langle x \rangle_\alpha}{2\Delta x_\alpha}\right)^2 + i \langle p \rangle_\alpha \frac{x'}{\hbar}\right],
 \end{aligned} \tag{8.277}$$

where

$$\langle x \rangle_\alpha = \langle \alpha | x | \alpha \rangle = \sqrt{\frac{2\hbar}{m\omega}} \operatorname{Re}(\alpha), \tag{8.278}$$

$$\Delta x_\alpha = \sqrt{\langle \alpha | (\Delta x)^2 | \alpha \rangle} = \sqrt{\frac{\hbar}{2m\omega}}, \tag{8.279}$$

one finds that

$$\begin{aligned}
 f(x') &= \langle x' | \rho | x' \rangle = \frac{1}{\pi \langle N \rangle} \left(\frac{m\omega}{\pi \hbar} \right)^{1/2} \\
 &\quad \times \int \int d^2 \alpha \exp \left(-\frac{|\alpha|^2}{\langle N \rangle} \right) \exp \left[-2 \left(\frac{x' - \langle x \rangle_\alpha}{2 \Delta x_\alpha} \right)^2 \right] \\
 &= \frac{1}{\pi \langle N \rangle} \left(\frac{m\omega}{\pi \hbar} \right)^{1/2} \\
 &\quad \times \int \int d^2 \alpha \exp \left(-\frac{|\alpha|^2}{\langle N \rangle} \right) \exp \left(-2 \left(\frac{x'}{\sqrt{\frac{2\hbar}{m\omega}}} - \text{Re}(\alpha) \right)^2 \right) \\
 &= \frac{\left(\frac{m\omega}{\pi \hbar} \right)^{1/2}}{\sqrt{1 + 2 \langle N \rangle}} e^{-2 \frac{\left(\frac{x'}{\sqrt{\frac{2\hbar}{m\omega}}} \right)^2}{1 + 2 \langle N \rangle}} \\
 &= \frac{1}{\sqrt{\pi}} \sqrt{\frac{1}{\frac{\hbar}{m\omega} (1 + 2 \langle N \rangle)}} e^{-2 \frac{\left(\frac{x'}{\sqrt{\frac{2\hbar}{m\omega}}} \right)^2}{1 + 2 \langle N \rangle}},
 \end{aligned} \tag{8.280}$$

thus

$$f(x') = \frac{1}{\xi \sqrt{\pi}} e^{-\left(\frac{x'}{\xi} \right)^2}, \tag{8.281}$$

where

$$\xi = \sqrt{\frac{\hbar}{m\omega} (1 + 2 \langle N \rangle)}, \tag{8.282}$$

and where

$$1 + 2 \langle N \rangle = 1 + 2 \frac{e^{-\beta \hbar \omega}}{1 - e^{-\beta \hbar \omega}} = \coth \left(\frac{\beta \hbar \omega}{2} \right). \tag{8.283}$$

15. Recall that the LC circuit is a harmonic oscillator.

a) In terms of the annihilation and creation operators

$$a = \sqrt{\frac{L\omega}{2\hbar}} \left(q + \frac{ip}{L\omega} \right), \tag{8.284}$$

$$a^\dagger = \sqrt{\frac{L\omega}{2\hbar}} \left(q - \frac{ip}{L\omega} \right), \tag{8.285}$$

one has

$$q = \sqrt{\frac{\hbar}{2L\omega}} (a + a^\dagger) , \quad (8.286)$$

$$\mathcal{H} = \hbar\omega \left(a^\dagger a + \frac{1}{2} \right) . \quad (8.287)$$

The density operator is given by

$$\rho = \frac{1}{Z} e^{-\beta\mathcal{H}} , \quad (8.288)$$

where

$$\beta = \frac{1}{k_{\text{B}}T} , \quad (8.289)$$

and

$$Z = \text{Tr} e^{-\beta\mathcal{H}} = \sum_{n=0}^{\infty} e^{-\beta\hbar\omega(n+\frac{1}{2})} = \frac{e^{-\frac{\beta\hbar\omega}{2}}}{1 - e^{-\beta\hbar\omega}} = \frac{1}{2 \sinh \frac{\beta\hbar\omega}{2}} , \quad (8.290)$$

thus

$$\langle q \rangle = \text{Tr} (q\rho) = \frac{1}{Z} \sqrt{\frac{\hbar}{2L\omega}} \sum_{n=0}^{\infty} \langle n | (a + a^\dagger) e^{-\beta\mathcal{H}} | n \rangle = 0 . \quad (8.291)$$

b) Similarly

$$\begin{aligned} \langle q^2 \rangle &= \text{Tr} (q^2\rho) \\ &= \frac{\hbar}{2L\omega} \frac{1}{Z} \sum_{n=0}^{\infty} \langle n | (a + a^\dagger)^2 e^{-\beta\mathcal{H}} | n \rangle \\ &= \frac{1}{L\omega^2} \frac{1}{Z} \sum_{n=0}^{\infty} \hbar\omega \left(n + \frac{1}{2} \right) e^{-\beta\hbar\omega(n+\frac{1}{2})} \\ &= \frac{1}{L\omega^2} \frac{1}{Z} \frac{dZ}{d\beta} \\ &= \frac{C\hbar\omega}{2} \coth \frac{\hbar\omega}{2k_{\text{B}}T} . \end{aligned} \quad (8.292)$$

16. In general, ρ_0 can be expressed as

$$\rho_0 = \sum_i w_i |\alpha^{(i)}\rangle \langle \alpha^{(i)}| , \quad (8.293)$$

where $0 \leq w_i \leq 1$, $\sum_i w_i = 1$, and where $\langle \alpha^{(i)} | \alpha^{(i)} \rangle = 1$. Assume first that the system is initially in the state $|\alpha^{(i)}\rangle$. The probability for this to be the case is w_i . In general, the possible results of a measurement of the observable A are the eigenvalues $\{a_n\}$. The probability p_n to measure the eigenvalue a_n given that the system is initially in state $|\alpha^{(i)}\rangle$ is given by

$$p_n = \langle \alpha^{(i)} | P_n | \alpha^{(i)} \rangle . \quad (8.294)$$

After a measurement of A with an outcome a_n the state vector collapses onto the corresponding eigensubspace and becomes

$$| \alpha^{(i)} \rangle \rightarrow \frac{P_n | \alpha^{(i)} \rangle}{\sqrt{\langle \alpha^{(i)} | P_n | \alpha^{(i)} \rangle}} . \quad (8.295)$$

Thus, given that the system is initially in state $| \alpha^{(i)} \rangle$ the final density operator is given by

$$\begin{aligned} \rho_1^{(i)} &= \sum_n \langle \alpha^{(i)} | P_n | \alpha^{(i)} \rangle \frac{P_n | \alpha^{(i)} \rangle}{\sqrt{\langle \alpha^{(i)} | P_n | \alpha^{(i)} \rangle}} \frac{\langle \alpha^{(i)} | P_n}{\sqrt{\langle \alpha^{(i)} | P_n | \alpha^{(i)} \rangle}} \\ &= \sum_n P_n | \alpha^{(i)} \rangle \langle \alpha^{(i)} | P_n . \end{aligned} \quad (8.296)$$

Averaging over all possible initial states thus yields

$$\rho_1 = \sum_i w_i \rho_1^{(i)} = \sum_n P_n \sum_i w_i | \alpha^{(i)} \rangle \langle \alpha^{(i)} | P_n = \sum_n P_n \rho_0 P_n . \quad (8.297)$$

17. Since $[V(t), V(t')] = 0$ the time evolution operator from initial time t_0 to time t is given by

$$\begin{aligned} u(t, t_0) &= \exp \left(-\frac{i}{\hbar} \int_{t_0}^t dt' V(t') \right) \\ &= \exp \left(\frac{ip_i A}{\hbar} x \right) , \end{aligned} \quad (8.298)$$

where

$$p_i = \int_{t_0}^t dt' f(t') . \quad (8.299)$$

While the initial state of the entire system at time t_0 is given by $| \Psi(t_0) \rangle = | \psi_i \rangle \otimes | \alpha \rangle$, the final state at time t is given by

$$\begin{aligned} | \Psi(t) \rangle &= u(t, t_0) | \Psi(t_0) \rangle \\ &= \sum_n c_n J_n | \psi_i \rangle \otimes | a_n \rangle , \end{aligned} \quad (8.300)$$

where the operator J_n is given by

$$J_n = \exp \left(\frac{ip_i a_n}{\hbar} x \right) . \quad (8.301)$$

- a) By introducing the identity operator $\int dp' |p'\rangle \langle p'| = 1_{\text{MD}}$ on the Hilbert space of the MD, where $|p'\rangle$ are eigenvectors of the momentum operator p , which is canonically conjugate to x , the state $|\Psi(t)\rangle$ can be expressed as

$$|\Psi(t)\rangle = \sum_n c_n \int dp' \langle p' | J_n |\psi_i\rangle |p'\rangle \otimes |a_n\rangle . \quad (8.302)$$

With the help of the general identity (3.76), which is given by

$$[p, A(x)] = -i\hbar \frac{dA}{dx} , \quad (8.303)$$

where $A(x)$ is a function of the operator x , one finds that

$$\begin{aligned} pJ_n |p'\rangle &= ([p, J_n] + J_n p) |p'\rangle \\ &= (p_1 a_n + p') J_n |p'\rangle , \end{aligned} \quad (8.304)$$

thus the vector $J_n |p'\rangle$ is an eigenvector of p with eigenvalue $p_1 a_n + p'$. Moreover, note that this vector, which is labeled as $|p' + p_1 a_n\rangle \equiv J_n |p'\rangle$, is normalized, provided that $|p'\rangle$ is normalized, since J_n is unitary. The momentum wavefunction $\phi(p') = \langle p' | \psi_i\rangle$ of the state $|\psi_i\rangle$ is related to the position wavefunction $\langle x' | \psi_i\rangle$ by a Fourier transform [see Eq. (3.60)]

$$\begin{aligned} \phi(p') &= \frac{\int_{-\infty}^{\infty} dx' e^{-\frac{ip'x'}{\hbar}} \langle x' | \psi_i\rangle}{\sqrt{2\pi\hbar}} \\ &= \frac{1}{\pi^{1/4} p_0^{1/2}} \exp\left(-\frac{1}{2} \left(\frac{p'}{p_0}\right)^2\right) , \end{aligned} \quad (8.305)$$

where

$$p_0 = \frac{\hbar}{x_0} . \quad (8.306)$$

In terms of $\phi(p')$ the state $|\Psi(t)\rangle$ thus can be expressed as

$$\begin{aligned} |\Psi(t)\rangle &= \sum_n c_n \int dp' \langle p' - p_1 a_n | \psi_i\rangle |p'\rangle \otimes |a_n\rangle \\ &= \sum_n c_n \int dp' \phi(p' - p_1 a_n) |p'\rangle \otimes |a_n\rangle . \end{aligned} \quad (8.307)$$

- b) The probability distribution $g(\mathcal{A})$ of the random variable \mathcal{A} can be calculated using Eq. (8.307)

$$\begin{aligned}
 g(\mathcal{A}) &= p_i \sum_{n'} |(\langle a_{n'} | \otimes \langle p_i \mathcal{A} |) |\Psi(t)\rangle|^2 \\
 &= p_i \sum_{n'} |c_{n'}|^2 |\phi(p_i(\mathcal{A} - a_{n'}))|^2 \\
 &= \frac{\eta}{\pi^{1/2}} \sum_{n'} |c_{n'}|^2 e^{-\eta^2(\mathcal{A} - a_{n'})^2},
 \end{aligned} \tag{8.308}$$

where

$$\eta = \frac{p_i}{p_0} = \frac{x_0}{\hbar} \int_{t_0}^{\infty} dt' f(t'). \tag{8.309}$$

The expectation value of \mathcal{A} is given by

$$\begin{aligned}
 \langle \mathcal{A} \rangle &= \int_{-\infty}^{\infty} d\mathcal{A}' g(\mathcal{A}') \mathcal{A}' \\
 &= \sum_{n'} |c_{n'}|^2 \frac{\eta}{\pi^{1/2}} \int_{-\infty}^{\infty} d\mathcal{A}'' e^{-(\eta \mathcal{A}'')^2} (\mathcal{A}'' + a_{n'}) \\
 &= \sum_{n'} |c_{n'}|^2 a_{n'}.
 \end{aligned} \tag{8.310}$$

- c) The density operator of the entire system is taken to be given by $\rho_f = |\Psi(\infty)\rangle \langle \Psi(\infty)|$ for this case. The additional measurement is associated with the observable B , which is assumed to be a function of the degrees of freedom of the MS only. This assumption allows expressing the expectation value \bar{B} of the observable B as

$$\begin{aligned}
 \bar{B} &= \text{Tr}(B\rho_f) \\
 &= \sum_{n'} \int dp' \langle a_{n'} | \otimes \langle p' | B\rho_f | p' \rangle \otimes | a_{n'} \rangle \\
 &= \sum_{n'} \langle a_{n'} | B\rho_R | a_{n'} \rangle,
 \end{aligned} \tag{8.311}$$

where ρ_R , which is given by

$$\rho_R = \int dp' \langle p' | \rho_f | p' \rangle, \tag{8.312}$$

is called the reduced density operator. Note that ρ_{R} is an operator on the Hilbert space of the MS. With the help of the expressions

$$|\Psi(\infty)\rangle = \sum_n c_{n'} \int dp'' \phi(p'' - p_i a_{n'}) |p''\rangle \otimes |a_{n'}\rangle, \quad (8.313)$$

$$\langle\Psi(\infty)| = \sum_{n'} c_{n'}^* \int dp''' \phi^*(p''' - p_i a_{n''}) \langle a_{n''}| \otimes \langle p'''|, \quad (8.314)$$

one finds that

$$\begin{aligned} \rho_{\text{R}} &= \sum_{n', n''} c_{n'} c_{n''}^* \int dp' \\ &\quad \times \phi(p' - p_i a_{n'}) \phi^*(p' - p_i a_{n''}) |a_{n'}\rangle \langle a_{n''}|. \end{aligned} \quad (8.315)$$

By employing the transformation of integration variable

$$x = \frac{2p' - p_i (a_{n'} + a_{n''})}{2p_0}, \quad (8.316)$$

and its inverse

$$p' = p_0 \left(x + \frac{p_i (a_{n'} + a_{n''})}{2} \right), \quad (8.317)$$

one finds that

$$\int dp' \phi(p' - p_i a_{n'}) \phi^*(p' - p_i a_{n''}) = e^{-\eta^2 \left(\frac{a_{n'} - a_{n''}}{2} \right)^2}, \quad (8.318)$$

thus

$$\rho_{\text{R}} = \sum_{n', n''} c_{n'} c_{n''}^* e^{-\eta^2 \left(\frac{a_{n'} - a_{n''}}{2} \right)^2} |a_{n'}\rangle \langle a_{n''}|. \quad (8.319)$$

18. The representation of the reduced density matrix $\rho_{\text{R}} = \text{Tr}_{\text{R}}(|\psi\rangle\langle\psi|)$ in the basis of the states $|g\rangle$ and $|e\rangle$ is given by [see Eq. (8.60)]

$$\rho_{\text{R}} \doteq \begin{pmatrix} |a_{\text{g}}|^2 \text{Tr}_{\text{R}}(|\alpha_{\text{g}}\rangle\langle\alpha_{\text{g}}|) & a_{\text{g}} a_{\text{e}}^* \text{Tr}_{\text{R}}(|\alpha_{\text{g}}\rangle\langle\alpha_{\text{e}}|) \\ a_{\text{g}}^* a_{\text{e}} \text{Tr}_{\text{R}}(|\alpha_{\text{e}}\rangle\langle\alpha_{\text{g}}|) & |a_{\text{e}}|^2 \text{Tr}_{\text{R}}(|\alpha_{\text{e}}\rangle\langle\alpha_{\text{e}}|) \end{pmatrix}, \quad (8.320)$$

where Tr_{R} is a partial trace with respect to the harmonic oscillator degrees of freedom. For any pair of state $|\alpha_1\rangle$ and $|\alpha_2\rangle$ the following holds

$$\text{Tr}_{\text{R}}(|\alpha_1\rangle\langle\alpha_2|) = \sum_{n=0}^{\infty} \langle n | \alpha_1 \rangle \langle \alpha_2 | n \rangle = \langle \alpha_2 | \alpha_1 \rangle, \quad (8.321)$$

where $|n\rangle$ is a number state of the harmonic oscillator, and thus

$$\rho_{\text{R}} \doteq \begin{pmatrix} |a_{\text{g}}|^2 & a_{\text{g}} a_{\text{e}}^* \langle \alpha_{\text{e}} | \alpha_{\text{g}} \rangle \\ a_{\text{g}}^* a_{\text{e}} \langle \alpha_{\text{g}} | \alpha_{\text{e}} \rangle & |a_{\text{e}}|^2 \end{pmatrix}, \quad (8.322)$$

provided that the states $|\alpha_{\text{g}}\rangle$ and $|\alpha_{\text{e}}\rangle$ are normalized. The normalization condition reads

$$\text{Tr } \rho_{\text{R}} = |a_{\text{g}}|^2 + |a_{\text{e}}|^2 = 1, \quad (8.323)$$

and the following holds [assuming Eq. (8.323) holds]

$$\begin{aligned} \text{Tr } \rho_{\text{R}}^2 &= |a_{\text{g}}|^4 + |a_{\text{e}}|^4 + 2 |a_{\text{g}} a_{\text{e}}^* \langle \alpha_{\text{e}} | \alpha_{\text{g}} \rangle|^2 \\ &= 1 - 2 |a_{\text{g}}|^2 |a_{\text{e}}|^2 \left(1 - |\langle \alpha_{\text{e}} | \alpha_{\text{g}} \rangle|^2 \right). \end{aligned} \quad (8.324)$$

Using the relation (5.252) one finds that

$$\langle \alpha_2 | \alpha_1 \rangle = e^{-\frac{|\alpha_1|^2 + |\alpha_2|^2 - 2\alpha_1 \alpha_2^*}{2}} = e^{-\frac{|\alpha_1 - \alpha_2|^2}{2} + i \text{Im}(\alpha_1 \alpha_2^*)}, \quad (8.325)$$

and thus

$$\text{Tr } \rho_{\text{R}}^2 = 1 - 2 |a_{\text{g}}|^2 |a_{\text{e}}|^2 \left(1 - e^{-|\alpha_{\text{g}} - \alpha_{\text{e}}|^2} \right). \quad (8.326)$$

19. It is convenient to employ the coordinate transformation

$$x' = \frac{x + y}{\sqrt{2}}, \quad (8.327)$$

$$y' = \frac{x - y}{\sqrt{2}}. \quad (8.328)$$

The Lagrangian of the system can be written using these coordinates [see Eq. (9.208)] as

$$\mathcal{L} = \mathcal{L}_+ + \mathcal{L}_-, \quad (8.329)$$

where

$$\mathcal{L}_+ = \frac{m \dot{x}'^2}{2} - \frac{m \omega^2}{2} (1 + \lambda) x'^2, \quad (8.330)$$

and

$$\mathcal{L}_- = \frac{m \dot{y}'^2}{2} - \frac{m \omega^2}{2} (1 - \lambda) y'^2. \quad (8.331)$$

Thus, the system is composed of two decoupled harmonic oscillators with angular resonance frequencies $\omega\sqrt{1 + \lambda}$ (for x') and $\omega\sqrt{1 - \lambda}$ (for y'). In thermal equilibrium according to Eq. (8.259) one has

$$\langle x'^2 \rangle = \frac{\hbar}{2m\omega\sqrt{1+\lambda}} \coth\left(\frac{\hbar\omega\sqrt{1+\lambda}\beta}{2}\right), \quad (8.332)$$

$$\langle y'^2 \rangle = \frac{\hbar}{2m\omega\sqrt{1-\lambda}} \coth\left(\frac{\hbar\omega\sqrt{1-\lambda}\beta}{2}\right), \quad (8.333)$$

where $\beta = 1/(k_{\text{B}}T)$. Moreover, due to symmetry, the following holds

$$\langle x' \rangle = \langle y' \rangle = 0, \quad (8.334)$$

$$\langle x'y' \rangle = 0. \quad (8.335)$$

With the help of the inverse transformation, which is given by

$$x = \frac{x' + y'}{\sqrt{2}}, \quad (8.336)$$

$$y = \frac{x' - y'}{\sqrt{2}}, \quad (8.337)$$

one thus finds

$$\langle x \rangle = 0, \quad (8.338)$$

and

$$\begin{aligned} \langle x^2 \rangle &= \frac{1}{2} \langle x'^2 + y'^2 \rangle \\ &= \frac{\hbar}{4m\omega} \left[\frac{\coth\left(\frac{\hbar\omega\sqrt{1+\lambda}\beta}{2}\right)}{\sqrt{1+\lambda}} + \frac{\coth\left(\frac{\hbar\omega\sqrt{1-\lambda}\beta}{2}\right)}{\sqrt{1-\lambda}} \right]. \end{aligned} \quad (8.339)$$

20. Using Eq. (5.169), which is given by

$$x_{(\text{H})}(t) = x_{(\text{H})}(0) \cos(\omega t) + \frac{p_{(\text{H})}(0)}{m\omega} \sin(\omega t), \quad (8.340)$$

one finds that

$$G(t) = \cos(\omega t) \langle x_{(\text{H})}^2(0) \rangle + \frac{\sin(\omega t)}{m\omega} \langle p_{(\text{H})}(0) x_{(\text{H})}(0) \rangle. \quad (8.341)$$

Using the relations

$$x = \sqrt{\frac{\hbar}{2m\omega}} (a + a^\dagger), \quad (8.342)$$

$$p = i\sqrt{\frac{m\hbar\omega}{2}} (-a + a^\dagger), \quad (8.343)$$

$$[a, a^\dagger] = 1, \quad (8.344)$$

one finds that

$$x^2 = \frac{\hbar}{2m\omega} \left(a^2 + (a^\dagger)^2 + 2a^\dagger a + 1 \right) , \quad (8.345)$$

$$\frac{px}{m\omega} = i \frac{\hbar}{2m\omega} \left(-a^2 + (a^\dagger)^2 - 1 \right) . \quad (8.346)$$

a) Thus, for the ground state [see Eqs. (5.28) and (5.29)]

$$G(t) = \frac{\hbar}{2m\omega} [\cos(\omega t) - i \sin(\omega t)] = \frac{\hbar}{2m\omega} \exp(-i\omega t) . \quad (8.347)$$

b) The density operator ρ is given by Eq. (8.266)

$$\rho = \frac{1}{\langle N \rangle + 1} \sum_{n=0}^{\infty} \left(\frac{\langle N \rangle}{\langle N \rangle + 1} \right)^n |n\rangle \langle n| , \quad (8.348)$$

where

$$\langle N \rangle = \text{Tr}(\rho N) = \frac{e^{-\beta\hbar\omega}}{1 - e^{-\beta\hbar\omega}} , \quad (8.349)$$

$N = a^\dagger a$, and where $\beta = 1/(k_B T)$. Using the fact that ρ is diagonal in the basis of number states one finds that $\langle a^2 \rangle = \langle (a^\dagger)^2 \rangle = 0$.

Combining all these results leads to

$$\begin{aligned} G(t) &= \frac{\hbar}{2m\omega} [(2\langle N \rangle + 1) \cos(\omega t) - i \sin(\omega t)] \\ &= \frac{\hbar}{2m\omega} \left[\coth \frac{\beta\hbar\omega}{2} \cos(\omega t) - i \sin(\omega t) \right] . \end{aligned} \quad (8.350)$$

21. The wave function of the coherent state $|\alpha\rangle$ is given by Eq. (5.51)

$$\begin{aligned} \psi_\alpha(x') &= \langle x' | \alpha \rangle \\ &= \exp\left(\frac{\alpha^{*2} - \alpha^2}{4}\right) \left(\frac{m\omega}{\pi\hbar}\right)^{1/4} \exp\left[-\left(\frac{x' - \langle x \rangle_\alpha}{2\Delta x_\alpha}\right)^2 + i \langle p \rangle_\alpha \frac{x'}{\hbar}\right] . \end{aligned} \quad (8.351)$$

where

$$\langle x \rangle_\alpha = \langle \alpha | x | \alpha \rangle = \sqrt{\frac{2\hbar}{m\omega}} \alpha' , \quad (8.352)$$

$$\langle p \rangle_\alpha = \langle \alpha | p | \alpha \rangle = \sqrt{2\hbar m\omega} \alpha'' , \quad (8.353)$$

$$\alpha' = \text{Re}(\alpha) , \quad (8.354)$$

$$\alpha'' = \text{Im}(\alpha) , \quad (8.355)$$

$$\Delta x_\alpha = \sqrt{\langle \alpha | (\Delta x)^2 | \alpha \rangle} = \sqrt{\frac{\hbar}{2m\omega}} , \quad (8.356)$$

Using the definition (8.63) and the identity

$$\int_{-\infty}^{\infty} \exp(-ax^2 + bx + c) dx = \sqrt{\frac{\pi}{a}} e^{\frac{1}{4} \frac{4c + b^2}{a}}, \quad (8.357)$$

one has

$$\begin{aligned} W(x', p') &= \frac{1}{2\pi} \int_{-\infty}^{\infty} \exp\left(i \frac{p' x''}{\hbar}\right) \left\langle x' - \frac{x''}{2} \middle| \alpha \right\rangle \langle \alpha \middle| x' + \frac{x''}{2} \rangle dx'' \\ &= \frac{\left(\frac{m\omega}{\pi\hbar}\right)^{1/2}}{2\pi} \int_{-\infty}^{\infty} dx'' \\ &\quad \times e^{-\left(\frac{x' - \frac{x''}{2} - \langle x \rangle_{\alpha}}{2\Delta x_{\alpha}}\right)^2 - \left(\frac{x' + \frac{x''}{2} - \langle x \rangle_{\alpha}}{2\Delta x_{\alpha}}\right)^2 + i\left(\frac{p' - \langle p \rangle_{\alpha}}{\hbar}\right) x''} \\ &= \frac{\left(\frac{m\omega}{\pi\hbar}\right)^{1/2}}{2\pi} \int_{-\infty}^{\infty} dx'' \\ &\quad \times e^{-\frac{(x' - \langle x \rangle_{\alpha})^2 + \left(\frac{x''}{2}\right)^2}{2(\Delta x_{\alpha})^2} + i\left(\frac{p' - \langle p \rangle_{\alpha}}{\hbar}\right) x''}, \end{aligned} \quad (8.358)$$

thus

$$W(x', p') = \frac{1}{\pi} e^{-\frac{1}{2} \left(\frac{x' - \langle x \rangle_{\alpha}}{\Delta x_{\alpha}}\right)^2 - \frac{1}{2} \left(\frac{p' - \langle p \rangle_{\alpha}}{\Delta p_{\alpha}}\right)^2}, \quad (8.359)$$

where [see Eq. (5.49)]

$$\Delta p_{\alpha} = \sqrt{\langle \alpha | (\Delta p)^2 | \alpha \rangle} = \sqrt{\frac{\hbar m \omega}{2}} = \frac{\hbar}{2\Delta x_{\alpha}}. \quad (8.360)$$

22. At time $t > 0$ the system is in a coherent state $|\alpha = \alpha_0 e^{-i\omega t}\rangle$, where [see Eqs. (5.53) and (5.267)]

$$\alpha_0 = \Delta_x \sqrt{\frac{m\omega}{2\hbar}}. \quad (8.361)$$

Thus, with the help of Eq. (8.359) one finds that the Wigner function of the system at time t is given by

$$W(x', p') = \frac{1}{\pi} e^{-\frac{1}{2} \left(\frac{x' - \langle x \rangle_{\alpha}}{\Delta x_{\alpha}}\right)^2 - \frac{1}{2} \left(\frac{p' - \langle p \rangle_{\alpha}}{\Delta p_{\alpha}}\right)^2}, \quad (8.362)$$

where

$$\langle x \rangle_{\alpha} = \Delta_x \cos(\omega t), \quad (8.363)$$

$$\langle p \rangle_{\alpha} = -m\omega \Delta_x \sin(\omega t), \quad (8.364)$$

$$\Delta x_{\alpha} = \sqrt{\frac{\hbar}{2m\omega}}, \quad (8.365)$$

$$\Delta p_{\alpha} = \sqrt{\frac{\hbar m \omega}{2}}. \quad (8.366)$$

23. The density operator [see Eq. (8.50)] is given by

$$\rho = \int \int d^2\alpha |\alpha\rangle \langle\alpha| P(\alpha) , \quad (8.367)$$

where $|\alpha\rangle$ is a coherent state, $d^2\alpha$ denotes infinitesimal area in the α complex plane,

$$P(\alpha) = \frac{1}{\pi \langle N \rangle} \exp\left(-\frac{|\alpha|^2}{\langle N \rangle}\right) , \quad (8.368)$$

and where

$$\langle N \rangle = \frac{e^{-\beta\hbar\omega}}{1 - e^{-\beta\hbar\omega}} \quad (8.369)$$

is the expectation value of the number operator N . Thus

$$W(x', p') = \int \int d^2\alpha P(\alpha) W_\alpha(x', p') . \quad (8.370)$$

where

$$W_\alpha(x', p') = \frac{1}{2\pi} \int_{-\infty}^{\infty} \exp\left(i\frac{p'x''}{\hbar}\right) \left\langle x' - \frac{x''}{2} \mid \alpha \right\rangle \left\langle \alpha \mid x' + \frac{x''}{2} \right\rangle dx'' , \quad (8.371)$$

which is the Wigner function of a coherent state $|\alpha\rangle$, was found to be given by [see Eq. (8.359)]

$$W(x', p') = \frac{1}{\pi} e^{-\frac{1}{2}\left(\frac{x' - \langle x \rangle_\alpha}{\Delta x_\alpha}\right)^2 - \frac{1}{2}\left(\frac{p' - \langle p \rangle_\alpha}{\Delta p_\alpha}\right)^2} , \quad (8.372)$$

where

$$\langle x \rangle_\alpha = \langle \alpha \mid x \mid \alpha \rangle = \sqrt{\frac{2\hbar}{m\omega}} \alpha' = 2\Delta x_\alpha \alpha' , \quad (8.373)$$

$$\langle p \rangle_\alpha = \langle \alpha \mid p \mid \alpha \rangle = \sqrt{2\hbar m\omega} \alpha'' = 2\Delta p_\alpha \alpha'' , \quad (8.374)$$

$$\alpha' = \text{Re}(\alpha) , \quad (8.375)$$

$$\alpha'' = \text{Im}(\alpha) , \quad (8.376)$$

$$\Delta x_\alpha = \sqrt{\langle \alpha \mid (\Delta x)^2 \mid \alpha \rangle} = \sqrt{\frac{\hbar}{2m\omega}} , \quad (8.377)$$

$$\Delta p_\alpha = \sqrt{\langle \alpha \mid (\Delta p)^2 \mid \alpha \rangle} = \sqrt{\frac{\hbar m\omega}{2}} = \frac{\hbar}{2\Delta x_\alpha} . \quad (8.378)$$

Thus $W(x', p')$ is given by

$$\begin{aligned}
W(x', p') &= \frac{1}{\pi^2 \langle N \rangle} \int \int d^2 \alpha e^{-\frac{|\alpha|^2}{\langle N \rangle}} e^{-\frac{1}{2} \left(\frac{x' - \langle x \rangle_\alpha}{\Delta x_\alpha} \right)^2} e^{-\frac{1}{2} \left(\frac{p' - \langle p \rangle_\alpha}{\Delta p_\alpha} \right)^2} \\
&= \frac{1}{\pi^2 \langle N \rangle} \int d\alpha' e^{-\frac{\alpha'^2}{\langle N \rangle}} e^{-\frac{1}{2} \left(\frac{x' - 2\Delta x_\alpha \alpha'}{\Delta x_\alpha} \right)^2} \int d\alpha'' e^{-\frac{\alpha''^2}{\langle N \rangle}} e^{-\frac{1}{2} \left(\frac{p' - 2\Delta p_\alpha \alpha''}{\Delta p_\alpha} \right)^2}.
\end{aligned} \tag{8.379}$$

With the help of the identity (5.149) one thus finds that

$$W(x', p') = \frac{1}{\pi} \frac{1}{2 \langle N \rangle + 1} e^{-\frac{1}{2} \frac{1}{2 \langle N \rangle + 1} \left[\left(\frac{x'}{\Delta x_\alpha} \right)^2 + \left(\frac{p'}{\Delta p_\alpha} \right)^2 \right]}, \tag{8.380}$$

where

$$2 \langle N \rangle + 1 = 1 + 2 \frac{e^{-\beta \hbar \omega}}{1 - e^{-\beta \hbar \omega}} = \coth \left(\frac{\beta \hbar \omega}{2} \right), \tag{8.381}$$

and where $\beta = 1/(k_B T)$.

24. With the help of Eq. (5.134) one finds that the wavefunction of the number state $|n = 1\rangle$ is given by

$$\psi_{n=1}(x') = \langle x' | n = 1 \rangle = \frac{\sqrt{2} \frac{x'}{x_0} \exp\left(-\frac{x'^2}{2x_0^2}\right)}{\pi^{1/4} x_0^{1/2}}, \tag{8.382}$$

where

$$x_0 = \sqrt{\frac{\hbar}{m\omega}}. \tag{8.383}$$

thus

$$W(x', p') = \frac{1}{\pi} \int_{-\infty}^{\infty} e^{i \frac{p' x''}{\hbar}} \frac{\frac{x' - \frac{x''}{2}}{x_0} e^{-\frac{(x' - \frac{x''}{2})^2}{2x_0^2}} \frac{x' + \frac{x''}{2}}{x_0} e^{-\frac{(x' + \frac{x''}{2})^2}{2x_0^2}}}{\pi^{1/2} x_0} dx'', \tag{8.384}$$

or

$$W(x', p') = \frac{e^{-\left(\frac{x'}{x_0}\right)^2}}{\pi} \frac{1}{\pi^{1/2}} \int_{-\infty}^{\infty} \left(\left(\frac{x'}{x_0} \right)^2 - \frac{X^2}{4} \right) e^{i \frac{p'}{p_0} X - \frac{X^2}{4}} dX, \tag{8.385}$$

where $X = x''/x_0$ and where $p_0 = \hbar/x_0$. The integration, which is performed with the help of Eq. (5.149), yields

$$W(x', p') = \frac{2}{\pi} e^{-\left(\frac{x'}{x_0}\right)^2 - \left(\frac{p'}{p_0}\right)^2} \left[\left(\frac{x'}{x_0} \right)^2 + \left(\frac{p'}{p_0} \right)^2 - \frac{1}{2} \right]. \tag{8.386}$$

Note that near the origin the Wigner function $W(x', p')$ becomes negative.

25. The relation (8.64) is proven by

$$\begin{aligned}
 & \hbar^{-1} \int_{-\infty}^{\infty} dp' W(x', p') \\
 &= \int_{-\infty}^{\infty} \left\langle x' - \frac{x''}{2} \left| \rho \right| x' + \frac{x''}{2} \right\rangle dx'' \underbrace{\frac{1}{2\pi\hbar} \int_{-\infty}^{\infty} dp' e^{i\frac{p'x''}{\hbar}}}_{\delta(x'')} \\
 &= \langle x' | \rho | x' \rangle .
 \end{aligned} \tag{8.387}$$

With the help of the identities (3.45) and (3.52) $W(x', p')$ can be expressed as

$$\begin{aligned}
 & W(x', p') \\
 &= \frac{1}{(2\pi)^2 \hbar} \int_{-\infty}^{\infty} dx'' \int_{-\infty}^{\infty} dp'' \int_{-\infty}^{\infty} dp''' e^{i\frac{p'x'' + p''(x' - \frac{x''}{2}) - p'''(x' + \frac{x''}{2})}{\hbar}} \langle p'' | \rho | p''' \rangle \\
 &= \frac{1}{2\pi} \int_{-\infty}^{\infty} dp'' \int_{-\infty}^{\infty} dp''' e^{i\frac{x'(p'' - p''')}{\hbar}} \langle p'' | \rho | p''' \rangle \underbrace{\frac{1}{2\pi\hbar} \int_{-\infty}^{\infty} dx'' e^{i\frac{x''(p' - \frac{p''}{2} - \frac{p'''}{2})}{\hbar}}}_{\delta(p' - \frac{p''}{2} - \frac{p'''}{2})} .
 \end{aligned} \tag{8.388}$$

The above result easily leads to (8.65)

$$\begin{aligned}
 & \hbar^{-1} \int_{-\infty}^{\infty} dx' W(x', p') \\
 &= \int_{-\infty}^{\infty} dp'' \int_{-\infty}^{\infty} dp''' \langle p'' | \rho | p''' \rangle \delta\left(p' - \frac{p''}{2} - \frac{p'''}{2}\right) \\
 & \quad \underbrace{\frac{1}{2\pi\hbar} \int_{-\infty}^{\infty} dx' e^{i\frac{x'(p'' - p''')}{\hbar}}}_{\delta(p'' - p''')} \\
 &= \langle p' | \rho | p' \rangle .
 \end{aligned} \tag{8.389}$$

26. For a pure state $\rho = |\alpha\rangle\langle\alpha|$ one finds that the Wigner function is given by [see Eq. (8.63)]

$$W(x', p') = \frac{1}{2\pi} \int_{-\infty}^{\infty} dx'' e^{i\frac{p'x''}{\hbar}} \psi_{\alpha}\left(x' - \frac{x''}{2}\right) \psi_{\alpha}^*\left(x' + \frac{x''}{2}\right) , \tag{8.390}$$

where $\psi_{\alpha}(x') = \langle x' | \alpha \rangle$ is the position wavefunction of $|\alpha\rangle$. Thus with the help of Schwartz inequality one finds that

$$\begin{aligned}
|W(x', p')|^2 &\leq \frac{1}{(2\pi)^2} \int_{-\infty}^{\infty} dx'' \left| e^{i\frac{p'x''}{\hbar}} \psi_{\alpha} \left(x' - \frac{x''}{2} \right) \right|^2 \\
&\quad \times \int_{-\infty}^{\infty} dx'' \left| \psi_{\alpha}^* \left(x' + \frac{x''}{2} \right) \right|^2,
\end{aligned} \tag{8.391}$$

thus

$$|W(x', p')| \leq \frac{1}{2\pi}. \tag{8.392}$$

27. The Hamiltonian operator of the system is given by

$$\mathcal{H} = \frac{p^2}{2m} + V(x), \tag{8.393}$$

where p is the canonical conjugate operator to the position operator x . With the help of Eq. (8.29), which reads

$$\frac{d\rho}{dt} = -\frac{1}{i\hbar} [\rho, \mathcal{H}], \tag{8.394}$$

one finds that

$$\begin{aligned}
\frac{dW}{dt} &= \frac{1}{2\pi} \int_{-\infty}^{\infty} dx'' e^{i\frac{p'x''}{\hbar}} \left\langle x' - \frac{x''}{2} \left| \frac{d\rho}{dt} \right| x' + \frac{x''}{2} \right\rangle \\
&= S_k + S_p,
\end{aligned} \tag{8.395}$$

where the term

$$S_k = -\frac{1}{2\pi i\hbar} \int_{-\infty}^{\infty} dx'' e^{i\frac{p'x''}{\hbar}} \left\langle x' - \frac{x''}{2} \left| \left[\rho, \frac{p^2}{2m} \right] \right| x' + \frac{x''}{2} \right\rangle \tag{8.396}$$

represents the contribution of the kinetic energy, and where the term

$$S_p = -\frac{1}{2\pi i\hbar} \int_{-\infty}^{\infty} dx'' e^{i\frac{p'x''}{\hbar}} \left\langle x' - \frac{x''}{2} \left| [\rho, V(x)] \right| x' + \frac{x''}{2} \right\rangle \tag{8.397}$$

represents the contribution of the potential energy. To evaluate the term S_k , the closure relation (2.23) is employed

$$1 = \sum_n |\phi_n\rangle \langle \phi_n|, \tag{8.398}$$

where $\{|\phi_n\rangle\}$ is an arbitrary orthonormal basis, in order to obtain the following relation

$$\begin{aligned} & \left\langle x' - \frac{x''}{2} \left| \left[\rho, \frac{p^2}{2m} \right] \right| x' + \frac{x''}{2} \right\rangle \\ &= \frac{1}{2m} \sum_n \left\langle x' - \frac{x''}{2} \left| \rho |\phi_n\rangle \langle \phi_n| p^2 \right| x' + \frac{x''}{2} \right\rangle \\ & \quad - \frac{1}{2m} \sum_n \left\langle x' - \frac{x''}{2} \left| p^2 |\phi_n\rangle \langle \phi_n| \rho \right| x' + \frac{x''}{2} \right\rangle . \end{aligned} \tag{8.399}$$

By introducing the variables

$$x''' = x' - \frac{x''}{2} , \tag{8.400}$$

$$x'''' = x' + \frac{x''}{2} , \tag{8.401}$$

and employing the relations [see Eq. (3.29)]

$$\left\langle x' - \frac{x''}{2} \left| p^2 |\phi_n\rangle \right. = -\hbar^2 \frac{d^2}{dx'''^2} \langle x''' | \phi_n \rangle , \tag{8.402}$$

$$\left. \langle \phi_n | p^2 \right| x' + \frac{x''}{2} \rangle = -\hbar^2 \frac{d^2}{dx''''^2} \langle x'''' | \phi_n \rangle^* , \tag{8.403}$$

one finds that (after removing the factor $\sum_n |\phi_n\rangle \langle \phi_n|$)

$$\begin{aligned} & \left\langle x' - \frac{x''}{2} \left| \left[\rho, \frac{p^2}{2m} \right] \right| x' + \frac{x''}{2} \right\rangle \\ &= \frac{\hbar^2}{2m} \left(\frac{d^2}{dx'''^2} - \frac{d^2}{dx''''^2} \right) \langle x''' | \rho | x'''' \rangle . \end{aligned} \tag{8.404}$$

Using the relations

$$\frac{d}{dx''''} = \frac{\partial x'}{\partial x''''} \frac{d}{dx'} + \frac{\partial x''}{\partial x''''} \frac{d}{dx''} = \frac{1}{2} \frac{d}{dx'} - \frac{d}{dx''} , \tag{8.405}$$

$$\frac{d}{dx''''} = \frac{\partial x'}{\partial x''''} \frac{d}{dx'} + \frac{\partial x''}{\partial x''''} \frac{d}{dx''} = \frac{1}{2} \frac{d}{dx'} + \frac{d}{dx''} , \tag{8.406}$$

one finds that

$$\frac{d^2}{dx'''^2} - \frac{d^2}{dx''''^2} = -2 \frac{d^2}{dx' dx''} , \tag{8.407}$$

and thus

$$\begin{aligned}
& \left\langle x' - \frac{x''}{2} \left| \left[\rho, \frac{p^2}{2m} \right] \right| x' + \frac{x''}{2} \right\rangle \\
&= -\frac{\hbar^2}{m} \frac{d^2}{dx' dx''} \left\langle x' - \frac{x''}{2} \left| \rho \right| x' + \frac{x''}{2} \right\rangle .
\end{aligned} \tag{8.408}$$

Inserting into Eq. (8.396) and integrating by parts with respect to x'' lead to

$$\begin{aligned}
S_k &= \frac{\hbar}{2\pi i m} \int_{-\infty}^{\infty} dx'' e^{\frac{ip'x''}{\hbar}} \frac{d^2}{dx' dx''} \left\langle x' - \frac{x''}{2} \left| \rho \right| x' + \frac{x''}{2} \right\rangle \\
&= -\frac{p'}{m} \frac{1}{2\pi} \int_{-\infty}^{\infty} dx'' e^{\frac{ip'x''}{\hbar}} \frac{d}{dx'} \left\langle x' - \frac{x''}{2} \left| \rho \right| x' + \frac{x''}{2} \right\rangle ,
\end{aligned} \tag{8.409}$$

or [see Eq. (8.63)]

$$S_k = -\frac{p'}{m} \frac{\partial W}{\partial x'} . \tag{8.410}$$

To evaluate S_p the following relation is employed

$$\begin{aligned}
& \left\langle x' - \frac{x''}{2} \left| [\rho, V(x)] \right| x' + \frac{x''}{2} \right\rangle \\
&= \left(V\left(x' + \frac{x''}{2}\right) - V\left(x' - \frac{x''}{2}\right) \right) \left\langle x' - \frac{x''}{2} \left| \rho \right| x' + \frac{x''}{2} \right\rangle .
\end{aligned} \tag{8.411}$$

The term $V(x' + x''/2) - V(x' - x''/2)$, which represents an odd function of x'' , can be Taylor expanded as

$$V\left(x' + \frac{x''}{2}\right) - V\left(x' - \frac{x''}{2}\right) = 2 \sum_{i=0}^{\infty} \frac{1}{(2l+1)!} \frac{\partial^{2l+1} V}{\partial (x')^{2l+1}} \left(\frac{x''}{2}\right)^{2l+1} . \tag{8.412}$$

As can be seen from Eq. (8.63), the following holds

$$\frac{1}{2\pi} \int_{-\infty}^{\infty} dx'' (x'')^{2l+1} e^{\frac{ip'x''}{\hbar}} \left\langle x' - \frac{x''}{2} \left| \rho \right| x' + \frac{x''}{2} \right\rangle = \left(\frac{\hbar}{i}\right)^{2l+1} \frac{\partial^{2l+1} W}{\partial (p')^{2l+1}} . \tag{8.413}$$

Employing the above results to evaluate Eq. (8.397) and separating the first term from all higher order terms yield

$$S_p = \frac{\partial V}{\partial x'} \frac{\partial W}{\partial p'} + \sum_{l=1}^{\infty} \frac{\left(\frac{\hbar}{2i}\right)^{2l}}{(2l+1)!} \frac{\partial^{2l+1} V}{\partial (x')^{2l+1}} \frac{\partial^{2l+1} W}{\partial (p')^{2l+1}}. \quad (8.414)$$

Combining Eqs. (8.410) and (8.414) yields

$$\frac{dW}{dt} = -\frac{p'}{m} \frac{\partial W}{\partial x'} + \frac{\partial V}{\partial x'} \frac{\partial W}{\partial p'} + \sum_{l=1}^{\infty} \frac{\left(\frac{\hbar}{2i}\right)^{2l}}{(2l+1)!} \frac{\partial^{2l+1} V}{\partial (x')^{2l+1}} \frac{\partial^{2l+1} W}{\partial (p')^{2l+1}}, \quad (8.415)$$

or in terms of the Poisson's brackets [see Eqs. (1.37) and (8.393)]

$$\frac{dW}{dt} = \{\mathcal{H}, W\} + \sum_{l=1}^{\infty} \frac{\left(\frac{\hbar}{2i}\right)^{2l}}{(2l+1)!} \frac{\partial^{2l+1} V}{\partial (x')^{2l+1}} \frac{\partial^{2l+1} W}{\partial (p')^{2l+1}}. \quad (8.416)$$

Note that when $\partial^{2l+1} V / \partial (x')^{2l+1} = 0$ for $l \geq 1$ the above result coincides with the classical equation of motion $dW/dt = \{\mathcal{H}, W\}$. Thus one concludes that the quantum time evolution of W of a harmonic oscillator is identical to the classical one.

28. With the help of Eq. (2.184) one finds that

$$\exp(-i\xi X - i\eta P) = e^{-\frac{i\xi\eta}{2}} e^{-i\eta P} e^{-i\xi X}. \quad (8.417)$$

By evaluating the trace in Eq. (8.68) using an orthonormal basis of dimensionless position eigenstates (i.e. $X|X'\rangle = X'|X'\rangle$) one finds that [see Eq. (3.19) and recall that $\text{Tr}(AB) = \text{Tr}(BA)$]

$$\begin{aligned} \tilde{W}(\xi, \eta) &= e^{-\frac{i\xi\eta}{2}} \int_{-\infty}^{\infty} dX' \langle X' | \rho e^{-i\eta P} e^{-i\xi X} | X' \rangle \\ &= e^{-\frac{i\xi\eta}{2}} \int_{-\infty}^{\infty} dX' e^{-i\xi X'} \langle X' | \rho | X' + \eta \rangle \\ &= \int_{-\infty}^{\infty} dX'' e^{-i\xi X''} \left\langle X'' - \frac{\eta}{2} \left| \rho \right| X'' + \frac{\eta}{2} \right\rangle, \end{aligned} \quad (8.418)$$

thus

$$\begin{aligned}
W(X', P') &= \frac{1}{(2\pi)^2} \int_{-\infty}^{\infty} \int_{-\infty}^{\infty} d\xi d\eta \tilde{W}(\xi, \eta) e^{i\xi X' + i\eta P'} \\
&= \frac{1}{2\pi} \int_{-\infty}^{\infty} d\eta \int_{-\infty}^{\infty} dX'' \left\langle X'' - \frac{\eta}{2} \left| \rho \right| X'' + \frac{\eta}{2} \right\rangle e^{i\eta P'} \\
&\quad \times \underbrace{\frac{1}{2\pi} \int_{-\infty}^{\infty} d\xi e^{-i\xi(X'' - X')}}_{\delta(X'' - X')} \\
&= \frac{1}{2\pi} \int_{-\infty}^{\infty} dX'' \left\langle X' - \frac{X''}{2} \left| \rho \right| X' + \frac{X''}{2} \right\rangle e^{iX'' P'} .
\end{aligned} \tag{8.419}$$

29. For the case $X' = P' = 0$ the operator Υ is given by

$$\Upsilon(0, 0) = \frac{1}{(2\pi)^2} \int_{-\infty}^{\infty} \int_{-\infty}^{\infty} d\xi d\eta e^{-i\xi X - i\eta P} , \tag{8.420}$$

or [see Eq. (2.184) and recall that $[X, P] = i$]

$$\Upsilon(0, 0) = \frac{1}{(2\pi)^2} \int_{-\infty}^{\infty} \int_{-\infty}^{\infty} d\xi d\eta e^{-\frac{i\xi\eta}{2}} e^{-i\eta P} e^{-i\xi X} , \tag{8.421}$$

and thus the following holds

$$\begin{aligned}
\Upsilon(0, 0) |X'\rangle &= \frac{1}{(2\pi)^2} \int_{-\infty}^{\infty} \int_{-\infty}^{\infty} d\xi d\eta e^{-\frac{i\xi\eta}{2}} e^{-i\eta P} e^{-i\xi X'} |X'\rangle \\
&= \frac{1}{2\pi} \int_{-\infty}^{\infty} d\eta e^{-i\eta P} |X'\rangle \underbrace{\frac{1}{2\pi} \int_{-\infty}^{\infty} d\xi e^{-i\xi(\frac{\eta}{2} + X')}}_{\delta(\frac{\eta}{2} + X')} \\
&= \pi^{-1} e^{2iX'P} |X'\rangle ,
\end{aligned} \tag{8.422}$$

or [see Eq. (3.19)]

$$\Upsilon(0, 0) |X'\rangle = \pi^{-1} |-X'\rangle , \tag{8.423}$$

which implies that $\Upsilon(0, 0)$ is related to the parity operator \mathcal{P} (8.75) by

$$\Upsilon(0,0) = \pi^{-1} \mathcal{P}. \quad (8.424)$$

By employing the relations

$$X = \frac{a + a^\dagger}{\sqrt{2}}, \quad P = \frac{a - a^\dagger}{\sqrt{2}i}, \quad (8.425)$$

together with Eq. (8.420) one finds that

$$\begin{aligned} \mathcal{P} &= \frac{1}{4\pi} \int_{-\infty}^{\infty} \int_{-\infty}^{\infty} d\xi d\eta e^{-i\xi \frac{a+a^\dagger}{\sqrt{2}} - i\eta \frac{a-a^\dagger}{\sqrt{2}i}} \\ &= \frac{1}{4\pi} \int_{-\infty}^{\infty} \int_{-\infty}^{\infty} d\xi d\eta e^{-\frac{i\xi+\eta}{\sqrt{2}} a - \frac{i\xi-\eta}{\sqrt{2}} a^\dagger}. \end{aligned} \quad (8.426)$$

The above result together with Eq. (5.38) yield

$$\begin{aligned} &\pi^{-1} D^\dagger \left(-\frac{X' + iP'}{\sqrt{2}} \right) \mathcal{P} D \left(-\frac{X' + iP'}{\sqrt{2}} \right) \\ &= \frac{1}{(2\pi)^2} \int_{-\infty}^{\infty} \int_{-\infty}^{\infty} d\xi d\eta e^{-\frac{i\xi+\eta}{\sqrt{2}} \left(a - \frac{X'+iP'}{\sqrt{2}} \right) - \frac{i\xi-\eta}{\sqrt{2}} \left(a^\dagger - \frac{X'-iP'}{\sqrt{2}} \right)} \\ &= \frac{1}{(2\pi)^2} \int_{-\infty}^{\infty} \int_{-\infty}^{\infty} d\xi d\eta e^{-\frac{i\xi+\eta}{\sqrt{2}} \left(\frac{X+iP}{\sqrt{2}} - \frac{X'+iP'}{\sqrt{2}} \right) - \frac{i\xi-\eta}{\sqrt{2}} \left(\frac{X-iP}{\sqrt{2}} - \frac{X'-iP'}{\sqrt{2}} \right)} \\ &= \frac{1}{(2\pi)^2} \int_{-\infty}^{\infty} \int_{-\infty}^{\infty} d\xi d\eta e^{i\xi(X'-X) + i\eta(P'-P)}, \end{aligned} \quad (8.427)$$

thus [see Eq. (8.72)]

$$\pi^{-1} D^\dagger \left(-\frac{X' + iP'}{\sqrt{2}} \right) \mathcal{P} D \left(-\frac{X' + iP'}{\sqrt{2}} \right) = \Upsilon(X', P'). \quad (8.428)$$

30. Note that [see Eq. (8.78)]

$$\hat{\delta}(a - \alpha') = \frac{1}{\pi^2} \int d^2\alpha'' e^{-\alpha'^* \alpha'' + \alpha' \alpha''^*} D(\alpha''), \quad (8.429)$$

where $D(\alpha) = \exp(\alpha a^\dagger - \alpha^* a)$ is the displacement operator (5.36).

a) The following holds [see Eqs. (8.429), (5.88) and (5.257)]

$$\begin{aligned}
& \text{Tr} \left[\hat{\delta}(a - \alpha') \hat{\delta}(a - \alpha'') \right] \\
&= \frac{1}{\pi^4} \int d^2 \alpha''' e^{-\alpha'^* \alpha''' + \alpha' \alpha'''^*} \int d^2 \alpha'''' e^{-\alpha''^* \alpha'''' + \alpha'' \alpha''''^*} \text{Tr} [D(\alpha''') D(\alpha''')] \\
&= \frac{1}{\pi^3} \int d^2 \alpha''' e^{(\alpha'' - \alpha')^* \alpha''' + (\alpha' - \alpha'') \alpha'''^*} \\
&= \frac{1}{\pi} \delta(\alpha' - \alpha'') .
\end{aligned} \tag{8.430}$$

b) With the help of Eqs. (8.77) and (8.79) one finds that

$$\begin{aligned}
\pi \text{Tr} \left[\hat{\delta}(a - \alpha') f(a, a^\dagger) \right] &= \pi \int d^2 \alpha'' \mathcal{F}(\alpha'', \alpha''^*) \text{Tr} \left[\hat{\delta}(a - \alpha') \hat{\delta}(a - \alpha'') \right] \\
&= \int d^2 \alpha'' \mathcal{F}(\alpha'', \alpha''^*) \delta(\alpha' - \alpha'') \\
&= \mathcal{F}(\alpha', \alpha'^*) .
\end{aligned} \tag{8.431}$$

c) For the case $f(a, a^\dagger) = \rho$, where ρ is the density operator, Eq. (8.80) yields [see Eq. (8.78)]

$$\begin{aligned}
& \text{Tr} \left[\hat{\delta}(a - \alpha') \rho \right] \\
&= \frac{1}{\pi^2} \int d^2 \alpha'' \text{Tr} \left(e^{(a^\dagger - \alpha'^*) \alpha'' - (a - \alpha') \alpha''^*} \rho \right) \\
&= \frac{1}{2\pi^2} \int_{-\infty}^{\infty} \int_{-\infty}^{\infty} d\eta d\xi \text{Tr} \left(e^{\left(\frac{X - iP}{\sqrt{2}} - \frac{X' - iP'}{\sqrt{2}} \right) \frac{\eta - i\xi}{\sqrt{2}} - \left(\frac{X + iP}{\sqrt{2}} - \frac{X' + iP'}{\sqrt{2}} \right) \frac{\eta + i\xi}{\sqrt{2}}} \rho \right) \\
&= \frac{1}{2\pi^2} \int_{-\infty}^{\infty} \int_{-\infty}^{\infty} d\eta d\xi e^{i\xi X' + i\eta P'} \text{Tr} \left[e^{-i\xi X - i\eta P} \rho \right] ,
\end{aligned} \tag{8.432}$$

where

$$X = \frac{a + a^\dagger}{\sqrt{2}}, \quad P = \frac{a - a^\dagger}{i\sqrt{2}}, \tag{8.433}$$

and where

$$\eta = \frac{\alpha'' + \alpha''^*}{\sqrt{2}}, \quad \xi = -\frac{\alpha'' - \alpha''^*}{i\sqrt{2}}, \tag{8.434}$$

$$X' = \frac{\alpha' + \alpha'^*}{\sqrt{2}}, \quad P' = \frac{\alpha' - \alpha'^*}{i\sqrt{2}}. \tag{8.435}$$

The comparison with Eq. (8.67) indicates that Eq. (8.81) holds.

d) The density operator ρ can be expressed in terms of the Wigner function $w(\alpha')$ as [see Eqs. (8.77), (8.80) and (8.81)]

$$\rho = 2\pi \int d^2 \alpha' \hat{\delta}(a - \alpha') w(\alpha'), \tag{8.436}$$

thus [see Eqs. (8.83), (8.429) and (5.39)]

$$\begin{aligned}
 Q(\alpha) &= 2 \int d^2\alpha' w(\alpha') \langle \alpha | \hat{\delta}(a - \alpha') | \alpha \rangle \\
 &= \frac{2}{\pi^2} \int d^2\alpha' \int d^2\alpha'' w(\alpha') e^{-\alpha'^* \alpha'' + \alpha' \alpha''^*} \langle \alpha | D(\alpha'') | \alpha \rangle \\
 &= \frac{2}{\pi^2} \int d^2\alpha' w(\alpha') \int d^2\alpha'' e^{(\alpha'^* - \alpha''^*) \alpha'' + (\alpha' - \alpha'') \alpha''^*} e^{-\frac{|\alpha''|^2}{2}},
 \end{aligned} \tag{8.437}$$

hence Eq. (8.84) holds [Eq. (5.149) yields $\int_{-\infty}^{\infty} dx e^{-x^2/2+Ax} = \sqrt{2\pi} e^{A^2/2}$].

31. The normalized homodyne observable X_ϕ can be expressed in terms of the dimensionless position and momentum operators X and P , which are given by

$$X = \frac{a + a^\dagger}{\sqrt{2}}, \quad P = \frac{a - a^\dagger}{i\sqrt{2}}, \tag{8.438}$$

and which satisfy $[X, P] = i$ [see Eq. (5.13)], as

$$\begin{aligned}
 X_\phi &= \frac{X - iP}{2} e^{i\phi} + \frac{X + iP}{2} e^{-i\phi} \\
 &= X \cos \phi + P \sin \phi.
 \end{aligned} \tag{8.439}$$

The associated dimensionless momentum operator P_ϕ is defined as $P_\phi = -X \sin \phi + P \cos \phi$, i.e.

$$\begin{pmatrix} X_\phi \\ P_\phi \end{pmatrix} = \begin{pmatrix} \cos \phi & \sin \phi \\ -\sin \phi & \cos \phi \end{pmatrix} \begin{pmatrix} X \\ P \end{pmatrix}, \tag{8.440}$$

and the inverse transformation is given by

$$\begin{pmatrix} X \\ P \end{pmatrix} = \begin{pmatrix} \cos \phi & -\sin \phi \\ \sin \phi & \cos \phi \end{pmatrix} \begin{pmatrix} X_\phi \\ P_\phi \end{pmatrix}. \tag{8.441}$$

- a) The expectation value

$$\langle e^{-i\zeta X_\phi} \rangle = \text{Tr} [\exp(-i\zeta X_\phi) \rho] \tag{8.442}$$

is the characteristic function of the probability distribution function $\text{Pr}(X'_\phi)$ of X'_ϕ , which is denoted below as $w(X'_\phi)$, and thus it is related to the Fourier transform $\tilde{w}_\phi(\zeta)$ of the probability distribution $w(X'_\phi)$ by

$$\langle e^{-i\zeta X_\phi} \rangle = \int_{-\infty}^{\infty} dX'_\phi w(X'_\phi) e^{-i\zeta X'_\phi} = \tilde{w}_\phi(\zeta). \tag{8.443}$$

On the other hand, the Fourier transform $\tilde{W}(\xi, \eta)$ of the Wigner function $W(X', P')$ is given by [see Eq. (8.68)]

$$\tilde{W}(\xi, \eta) = \text{Tr}[\exp(-i\xi X - i\eta P) \rho] . \quad (8.444)$$

The comparison between Eq. (8.442) and Eq. (8.444) yields the following relation (recall that $X_\phi = X \cos \phi + P \sin \phi$)

$$\tilde{W}(\zeta \cos \phi, \zeta \sin \phi) = \tilde{w}_\phi(\zeta) . \quad (8.445)$$

Applying the inverse Fourier transform to Eq. (8.443) leads to [see Eq. (8.67)]

$$\begin{aligned} w(X'_\phi) &= \frac{1}{2\pi} \int_{-\infty}^{\infty} d\zeta e^{i\zeta X'_\phi} \tilde{w}_\phi(\zeta) \\ &= \frac{1}{2\pi} \int_{-\infty}^{\infty} d\zeta e^{i\zeta X'_\phi} \tilde{W}(\zeta \cos \phi, \zeta \sin \phi) , \end{aligned} \quad (8.446)$$

and thus by employing the inverse Fourier transform to Eq. (8.67)

$$\tilde{W}(\xi', \eta') = \int_{-\infty}^{\infty} \int_{-\infty}^{\infty} dX' dP' e^{-i\xi' X' - i\eta' P'} W(X', P') , \quad (8.447)$$

one finds that

$$w(X'_\phi) = \frac{1}{2\pi} \int_{-\infty}^{\infty} \int_{-\infty}^{\infty} \int_{-\infty}^{\infty} d\zeta dX' dP' e^{-i\zeta(X' \cos \phi + P' \sin \phi - X'_\phi)} W(X', P') . \quad (8.448)$$

The variable transformation (8.441) leads to

$$\begin{aligned} w(X'_\phi) &= \int_{-\infty}^{\infty} \int_{-\infty}^{\infty} dX''_\phi dP'_\phi W(X''_\phi \cos \phi - P'_\phi \sin \phi, X''_\phi \sin \phi + P'_\phi \cos \phi) \\ &\quad \times \underbrace{\frac{1}{2\pi} \int_{-\infty}^{\infty} d\zeta e^{-i\zeta(X''_\phi - X'_\phi)}}_{\delta(X''_\phi - X'_\phi)} \\ &= \int_{-\infty}^{\infty} dP'_\phi W(X'_\phi \cos \phi - P'_\phi \sin \phi, X'_\phi \sin \phi + P'_\phi \cos \phi) . \end{aligned} \quad (8.449)$$

b) The relation (8.445) allows evaluating the Wigner function, which is related to its Fourier transformed function $\tilde{W}(\xi, \eta)$ by Eq. (8.67), using the so-called inverse Radon transform. In polar coordinates (8.67) becomes

$$W(X', P') = \frac{1}{(2\pi)^2} \int_{-\infty}^{\infty} d\zeta \int_0^{\pi} d\phi |\zeta| \tilde{W}(\zeta \cos \phi, \zeta \sin \phi) e^{i\zeta(X' \cos \phi + P' \sin \phi)}, \quad (8.450)$$

thus with the help of Eq. (8.445) one finds that

$$W(X', P') = \frac{1}{(2\pi)^2} \int_{-\infty}^{\infty} d\zeta \int_0^{\pi} d\phi |\zeta| \tilde{w}_\phi(\zeta) e^{i\zeta(X' \cos \phi + P' \sin \phi)}, \quad (8.451)$$

thus [see Eq. (8.443)]

$$W(X', P') = \frac{1}{(2\pi)^2} \int_{-\infty}^{\infty} d\zeta \int_0^{\pi} d\phi \int_{-\infty}^{\infty} dX'_\phi |\zeta| w(X'_\phi) e^{i\zeta(X' \cos \phi + P' \sin \phi - X'_\phi)}. \quad (8.452)$$

32. The density operator [see Eq. (8.50)] is given by

$$\rho = \int \int d^2\alpha |\alpha\rangle \langle \alpha| P(\alpha), \quad (8.453)$$

where $|\alpha\rangle$ is a coherent state, $d^2\alpha$ denotes infinitesimal area in the α complex plane,

$$P(\alpha) = \frac{1}{\pi \langle N \rangle} \exp\left(-\frac{|\alpha|^2}{\langle N \rangle}\right), \quad (8.454)$$

and where

$$\langle N \rangle = \frac{e^{-\beta\hbar\omega}}{1 - e^{-\beta\hbar\omega}} \quad (8.455)$$

is the expectation value of the number operator N . By employing the expression for the wave function $\psi_\alpha(x') = \langle x' | \alpha \rangle$ of a coherent state which is given by [see Eq. (5.51)]

$$\begin{aligned} \psi_\alpha(x') &= \langle x' | \alpha \rangle \\ &= \exp\left(\frac{\alpha^{*2} - \alpha^2}{4}\right) \left(\frac{m\omega}{\pi\hbar}\right)^{1/4} \exp\left[-\left(\frac{x' - \langle x \rangle_\alpha}{2\Delta x_\alpha}\right)^2 + i\langle p \rangle_\alpha \frac{x'}{\hbar}\right], \end{aligned} \quad (8.456)$$

where

$$\langle x \rangle_\alpha = \langle \alpha | x | \alpha \rangle = \sqrt{\frac{2\hbar}{m\omega}} \alpha' , \quad (8.457)$$

$$\langle p \rangle_\alpha = \langle \alpha | p | \alpha \rangle = \sqrt{2\hbar m\omega} \alpha'' , \quad (8.458)$$

$$\alpha' = \text{Re}(\alpha) , \quad (8.459)$$

$$\alpha'' = \text{Im}(\alpha) , \quad (8.460)$$

$$\Delta x_\alpha = \sqrt{\langle \alpha | (\Delta x)^2 | \alpha \rangle} = \sqrt{\frac{\hbar}{2m\omega}} , \quad (8.461)$$

one finds that

$$\begin{aligned} \langle x'' | \rho | x' \rangle &= \int \int d^2\alpha P(\alpha) \langle x'' | \alpha \rangle \langle \alpha | x' \rangle \\ &= \frac{\left(\frac{m\omega}{\pi\hbar}\right)^{1/2}}{\pi \langle N \rangle} \int \int d^2\alpha \exp\left(-\frac{|\alpha|^2}{\langle N \rangle}\right) \\ &\quad \times \exp\left[-\left(\frac{x' - \langle x \rangle_\alpha}{2\Delta x_\alpha}\right)^2 - \left(\frac{x'' - \langle x \rangle_\alpha}{2\Delta x_\alpha}\right)^2 + i \langle p \rangle_\alpha \frac{(x'' - x')}{\hbar}\right] \\ &= \frac{\left(\frac{m\omega}{\pi\hbar}\right)^{1/2}}{\pi \langle N \rangle} \int \int d^2\alpha \exp\left(-\frac{\alpha'^2 + \alpha''^2}{\langle N \rangle}\right) \\ &\quad \times \exp\left[-\left(\frac{X' - 2\alpha'}{2}\right)^2 - \left(\frac{X'' - 2\alpha''}{2}\right)^2 + i\alpha''(X'' - X')\right] \\ &= \frac{\left(\frac{m\omega}{\pi\hbar}\right)^{1/2}}{\pi \langle N \rangle} \int d\alpha' \exp\left(-\frac{2\langle N \rangle + 1}{\langle N \rangle} \alpha'^2 + (X' + X'') \alpha' - \frac{X'^2 + X''^2}{4}\right) \\ &\quad \times \int d\alpha'' \exp\left(-\frac{\alpha''^2}{\langle N \rangle} + i\alpha''(X'' - X')\right) . \end{aligned} \quad (8.462)$$

where

$$X' = \sqrt{\frac{2m\omega}{\hbar}} x' , \quad (8.463)$$

$$X'' = \sqrt{\frac{2m\omega}{\hbar}} x'' . \quad (8.464)$$

With the help of the identity (5.149) one finds that

$$\langle x'' | \rho | x' \rangle = \left(\frac{m\omega}{\pi\hbar}\right)^{1/2} \sqrt{\frac{1}{2\langle N \rangle + 1}} e^{\frac{-(x'^2 + x''^2) - \langle N \rangle (x'' - x')^2 + \frac{\langle N \rangle (x' + x'')^2}{2\langle N \rangle + 1}}{4}} , \quad (8.465)$$

or using the identity

$$X'^2 + X''^2 = \frac{(X' + X'')^2 + (X' - X'')^2}{2}, \quad (8.466)$$

one has

$$\langle x'' | \rho | x' \rangle = \left(\frac{m\omega}{\pi\hbar} \right)^{1/2} \sqrt{\frac{1}{2\langle N \rangle + 1}} e^{-\frac{\left(\frac{x'+x''}{2}\right)^2}{2(2\langle N \rangle + 1)} - \left(\frac{x'-x''}{2}\right)^2 \frac{2\langle N \rangle + 1}{2}}. \quad (8.467)$$

In terms of x' and x'' this result can be written as

$$\langle x'' | \rho | x' \rangle = \frac{1}{\xi\sqrt{\pi}} e^{-\left(\frac{x'+x''}{2\xi}\right)^2 - (2\langle N \rangle + 1)^2 \left(\frac{x'-x''}{2\xi}\right)^2}, \quad (8.468)$$

where

$$\xi = \sqrt{\frac{\hbar}{m\omega}} (2\langle N \rangle + 1), \quad (8.469)$$

$$2\langle N \rangle + 1 = 1 + 2 \frac{e^{-\beta\hbar\omega}}{1 - e^{-\beta\hbar\omega}} = \coth\left(\frac{\beta\hbar\omega}{2}\right), \quad (8.470)$$

and where $\beta = 1/(k_B T)$. Alternatively, the result can be expressed as

$$\langle x'' | \rho | x' \rangle = \frac{e^{-\tanh\left(\frac{\beta\hbar\omega}{2}\right)\left(\frac{x'+x''}{2x_0}\right)^2 - \coth\left(\frac{\beta\hbar\omega}{2}\right)\left(\frac{x'-x''}{2x_0}\right)^2}}{x_0 \sqrt{\pi \coth\left(\frac{\beta\hbar\omega}{2}\right)}}, \quad (8.471)$$

where

$$x_0 = \sqrt{\frac{\hbar}{m\omega}}. \quad (8.472)$$

33. The following holds [see Eqs. (8.10), (8.36)]

$$\langle e^{-i\zeta X_\phi} \rangle = \frac{\text{Tr}(e^{-\beta\mathcal{H}} e^{-i\zeta X_\phi})}{\text{Tr}(e^{-\beta\mathcal{H}})}, \quad (8.473)$$

where $\mathcal{H} = \hbar\omega(a^\dagger a + 1/2)$ [see Eq. (5.16)]. Using the identity (2.182) and the commutation relation $[a, a^\dagger] = 1$ [see Eq. (5.13)] one finds that the following holds

$$e^{i\phi a^\dagger} a e^{-i\phi a^\dagger} = a e^{-i\phi}, \quad (8.474)$$

$$e^{i\phi a^\dagger} a^\dagger e^{-i\phi a^\dagger} = a^\dagger e^{i\phi}, \quad (8.475)$$

and thus X_ϕ can be expressed as

$$X_\phi = e^{i\phi a^\dagger} X_0 e^{-i\phi a^\dagger}, \quad (8.476)$$

where X_0 , which is given by

$$X_0 = \frac{a + a^\dagger}{\sqrt{2}} , \quad (8.477)$$

is related to the position operator x by [see Eq. (5.11)]

$$x = x_0 X_0 , \quad (8.478)$$

where

$$x_0 = \sqrt{\frac{\hbar}{m\omega}} . \quad (8.479)$$

The last result implies that

$$e^{-i\zeta X_\phi} = e^{i\phi a^\dagger a} e^{-i\zeta X_0} e^{-i\phi a^\dagger a} , \quad (8.480)$$

and thus [see Eq. (8.473) and recall that $\text{Tr}(AB) = \text{Tr}(BA)$]

$$\langle e^{-i\zeta X_\phi} \rangle = \langle e^{-i\zeta X_0} \rangle = \left\langle e^{-i\zeta \sqrt{\frac{m\omega}{\hbar}} x} \right\rangle . \quad (8.481)$$

In other words, $\langle e^{-i\zeta X_\phi} \rangle$ is found to be independent on ϕ . The expectation value $\langle e^{-i\zeta \sqrt{\frac{m\omega}{\hbar}} x} \rangle$ can be calculated by employing the expression for the matrix elements $\langle x'' | \rho | x' \rangle$ of the density operator ρ given by Eq. (8.471)

$$\begin{aligned} \langle e^{-i\zeta X_\phi} \rangle &= \int_{-\infty}^{\infty} dx' \langle x' | \rho e^{-i\zeta \sqrt{\frac{m\omega}{\hbar}} x} | x' \rangle \\ &= \int_{-\infty}^{\infty} dx' e^{-i\zeta \sqrt{\frac{m\omega}{\hbar}} x'} \frac{e^{-\tanh\left(\frac{\beta\hbar\omega}{2}\right)\left(\frac{x'}{x_0}\right)^2}}{x_0 \sqrt{\pi \coth\left(\frac{\beta\hbar\omega}{2}\right)}} , \end{aligned} \quad (8.482)$$

and where $\beta = 1/(k_B T)$. Using the identity (5.149) one finds that

$$\langle e^{-i\zeta X_\phi} \rangle = e^{-\frac{\zeta^2 \coth\left(\frac{\beta\hbar\omega}{2}\right)}{4}} . \quad (8.483)$$

In view of Eq. (8.259), according to which

$$\frac{1}{2} \coth\left(\frac{\beta\hbar\omega}{2}\right) = \langle N \rangle + \frac{1}{2} = \langle X_0^2 \rangle , \quad (8.484)$$

where [see Eq. (8.455)]

$$\langle N \rangle = \frac{e^{-\beta\hbar\omega}}{1 - e^{-\beta\hbar\omega}} , \quad (8.485)$$

the above result can be rewritten as

$$\langle e^{-i\zeta X_\phi} \rangle = e^{-\frac{\zeta^2 \langle x_0^2 \rangle}{2}} . \quad (8.486)$$

The factor $\langle e^{-i\zeta X_\phi} \rangle$ is the characteristic function of the probability distribution function $\Pr(X'_\phi)$ of X'_ϕ , which is denoted below as $w(X'_\phi)$, and thus it is related to the Fourier transform $\tilde{w}_\phi(\zeta)$ of the probability distribution $w(X'_\phi)$ by [see Eq. (8.443)]

$$\langle e^{-i\zeta X_\phi} \rangle = \int_{-\infty}^{\infty} dX'_\phi w(X'_\phi) e^{-i\zeta X'_\phi} = \tilde{w}_\phi(\zeta) . \quad (8.487)$$

With the help of Eqs. (8.443), (8.445) and (8.486) one finds that the Fourier transform $\tilde{W}(\xi, \eta)$ of the Wigner function $W(X', P')$ satisfies the following relation for any real ϕ

$$\tilde{W}(\zeta \cos \phi, \zeta \sin \phi) = e^{-\frac{\zeta^2 \langle x_0^2 \rangle}{2}} , \quad (8.488)$$

and thus

$$\tilde{W}(\xi, \eta) = e^{-\frac{(\xi^2 + \eta^2) \langle x_0^2 \rangle}{2}} . \quad (8.489)$$

The inverse Fourier transformation [see Eqs. (5.149) and (8.419)] yields

$$\begin{aligned} W(X', P') &= \frac{1}{2\pi} \int_{-\infty}^{\infty} d\xi e^{-\frac{\xi^2 \langle x_0^2 \rangle}{2}} e^{i\xi X'} \frac{1}{2\pi} \int_{-\infty}^{\infty} d\eta e^{-\frac{\eta^2 \langle x_0^2 \rangle}{2}} e^{i\eta P'} \\ &= \frac{1}{2\pi \langle X_0^2 \rangle} e^{-\frac{X'^2 + P'^2}{2 \langle X_0^2 \rangle}} \\ &= \frac{1}{\pi (2 \langle N \rangle + 1)} e^{-\frac{X'^2 + P'^2}{2 \langle N \rangle + 1}} . \end{aligned} \quad (8.490)$$

It is easy to see that the above result for the Wigner function $W(X', P')$ for the dimensionless variables X' and P' is consistent with Eq. (8.380) for the Wigner function $W(x', p')$ for the displacement x' and momentum p' variables.

34. By using Eqs. (8.67) and employing cylindrical coordinates

$$\begin{aligned} \xi &= \zeta \cos \phi , \quad \eta = \zeta \sin \phi , \\ X' &= R' \cos \theta , \quad P' = R' \sin \theta , \end{aligned} \quad (8.491)$$

one finds that

$$W(X', P') = \frac{1}{(2\pi)^2} \int_0^\infty d\zeta \zeta \int_{-\pi}^\pi d\phi \tilde{W}(\zeta \cos \phi, \zeta \sin \phi) e^{i\zeta R' \cos(\phi-\theta)}, \quad (8.492)$$

thus since $w(X'_\phi)$ is ϕ independent [see Eqs. (8.443) and (8.445)] one has [note that contrary to Eq. (8.452), integration over ζ below is taken to be over positive values only]

$$W(X', P') = \frac{1}{(2\pi)^2} \int_0^\infty d\zeta \zeta \tilde{w}(\zeta) \int_{-\pi}^\pi d\phi e^{i\zeta R' \cos(\phi-\theta)}, \quad (8.493)$$

where

$$\tilde{w}(\zeta) = \int_{-\infty}^\infty dX'_\phi w(X'_\phi) e^{-i\zeta X'_\phi}. \quad (8.494)$$

With the help of Jacobi-Anger expansion

$$\exp(iz \cos x) = \sum_{n=-\infty}^\infty i^n J_n(z) e^{inx}, \quad (8.495)$$

one finds that

$$\begin{aligned} \int_{-\pi}^\pi d\phi e^{i\zeta R' \cos(\phi-\theta)} &= \sum_{n=-\infty}^\infty i^n J_n(\zeta R') e^{-in\theta} \int_{-\pi}^\pi d\phi e^{in\phi} \\ &= 2\pi J_0(\zeta R'), \end{aligned} \quad (8.496)$$

thus

$$W(X', P') = \frac{1}{2\pi} \int_0^\infty d\zeta \zeta \tilde{w}(\zeta) J_0\left(\zeta \sqrt{X'^2 + P'^2}\right), \quad (8.497)$$

or

$$W(X', P') = \frac{\int_0^\infty dz \tilde{w}\left(\frac{z}{\sqrt{X'^2 + P'^2}}\right) z J_0(z)}{2\pi (X'^2 + P'^2)}. \quad (8.498)$$

As an example of the usage of Eq. (8.497), consider the case of a harmonic oscillator having angular resonance frequency ω in thermal equilibrium at temperature T . For this case [see Eq. (8.486)]

$$\tilde{w}(\zeta) = e^{-\frac{\zeta^2 \langle X_0^2 \rangle}{2}}, \quad (8.499)$$

and thus with the help of the identity

$$\int_0^\infty z e^{-\frac{z^2 A^2}{2}} J_0(zR) dz = \frac{1}{A^2} e^{-\frac{R^2}{2A^2}}, \quad (8.500)$$

one finds that Eq. (8.497) yields

$$W(X', P') = \frac{1}{2\pi \langle X_0^2 \rangle} e^{-\frac{X'^2 + P'^2}{2 \langle X_0^2 \rangle}}, \quad (8.501)$$

in agreement with Eq. (8.490).

35. The density operator evolves in time according to [see Eq. (8.31)]

$$\rho(t) = u(t) \rho_0 u^\dagger(t), \quad (8.502)$$

where $u(t)$ is the time evolution operator for the system. The Wigner function $W(X', P'; t)$ can be expressed according to Eq. (8.452) as

$$W(X', P'; t) = \frac{1}{(2\pi)^2} \int_{-\infty}^{\infty} d\zeta \int_0^\pi d\phi \int_{-\infty}^{\infty} dX'_\phi |\zeta| w(X'_\phi) e^{i\zeta(X' \cos \phi + P' \sin \phi - X'_\phi)}, \quad (8.503)$$

where $w(X'_\phi)$ is the probability distribution function of the observable X_ϕ , which is given by

$$X_\phi = \frac{a^\dagger e^{i\phi} + a e^{-i\phi}}{\sqrt{2}}. \quad (8.504)$$

In terms of the density operator $\rho(t)$ one has [recall that $\text{Tr}(AB) = \text{Tr}(BA)$]

$$\begin{aligned} w(X'_\phi) &= \text{Tr}(|X'_\phi\rangle \langle X'_\phi| \rho(t)) \\ &= \text{Tr}(u^\dagger(t) |X'_\phi\rangle \langle X'_\phi| u(t) \rho_0), \end{aligned} \quad (8.505)$$

where $|X'_\phi\rangle$ is an eigenvector of X_ϕ with eigenvalue X'_ϕ , i.e. $X_\phi |X'_\phi\rangle = X'_\phi |X'_\phi\rangle$. With the help of Eqs. (2.182) and (4.9) one finds that

$$\begin{aligned}
u^\dagger(t) X_\phi u(t) &= e^{i\omega(a^\dagger a + \frac{1}{2})t} \frac{a^\dagger e^{i\phi} + a e^{-i\phi}}{\sqrt{2}} e^{-i\omega(a^\dagger a + \frac{1}{2})t} \\
&= e^{i\omega t a^\dagger a} \frac{a^\dagger e^{i\phi} + a e^{-i\phi}}{\sqrt{2}} e^{-i\omega t a^\dagger a} \\
&= \frac{a^\dagger e^{i(\phi + \omega t)} + a e^{-i(\phi + \omega t)}}{\sqrt{2}} \\
&= X_{\phi + \omega t},
\end{aligned} \tag{8.506}$$

thus the following holds

$$X_{\phi + \omega t} u^\dagger(t) |X'_\phi\rangle = X'_\phi u^\dagger(t) |X'_\phi\rangle, \tag{8.507}$$

i.e. $u^\dagger(t) |X'_\phi\rangle$ is an eigenvector of $X_{\phi + \omega t}$ with eigenvalue X'_ϕ . This eigenvector is labeled below as $|X'_{\phi + \omega t}\rangle$. Using these results and the trigonometric identities

$$\cos(x + y) = \cos x \cos y - \sin x \sin y, \tag{8.508}$$

$$\sin(x + y) = \cos x \sin y + \sin x \cos y, \tag{8.509}$$

the Wigner function $W(X', P'; t)$ becomes

$$\begin{aligned}
W(X', P'; t) &= \frac{1}{(2\pi)^2} \int_{-\infty}^{\infty} d\zeta \int_0^\pi d\phi \int_{-\infty}^{\infty} dX'_\phi |\zeta| \\
&\quad \times \text{Tr}(|X'_{\phi + \omega t}\rangle \langle X'_{\phi + \omega t}| \rho_0) e^{i\zeta(X' \cos \phi + P' \sin \phi - X'_\phi)} \\
&= \frac{1}{(2\pi)^2} \int_{-\infty}^{\infty} d\zeta \int_0^\pi d\phi' \int_{-\infty}^{\infty} dX'_\phi |\zeta| \\
&\quad \times \text{Tr}(|X'_{\phi'}\rangle \langle X'_{\phi'}| \rho_0) e^{i\zeta(X' \cos(\phi' - \omega t) + P' \sin(\phi' - \omega t) - X'_\phi)},
\end{aligned} \tag{8.510}$$

thus

$$W(X', P'; t) = W(X' \cos(\omega t) - P' \sin(\omega t), X' \sin(\omega t) + P' \cos(\omega t); 0), \tag{8.511}$$

i.e. the time evolution of the Wigner function represents rigid rotation in phase space at angular velocity ω .

36. The Wigner function $W(X', P')$ can be expressed as [see Eq. (8.67)]

$$W(X', P') = \frac{1}{(2\pi)^2} \int_{-\infty}^{\infty} \int_{-\infty}^{\infty} d\xi d\eta \tilde{W}(\xi, \eta) e^{i\xi X' + i\eta P'}, \tag{8.512}$$

where

$$\tilde{W}(\xi, \eta) = \text{Tr}(D(\alpha)\rho) , \quad (8.513)$$

and where

$$\alpha = \frac{\xi + i\eta}{\sqrt{2}i} , \quad (8.514)$$

thus for the displaced system one has [see Eq. (5.41) and recall that $\text{Tr}(AB) = \text{Tr}(BA)$]

$$\begin{aligned} W_\alpha(X', P') &= \frac{1}{(2\pi)^2} \int_{-\infty}^{\infty} \int_{-\infty}^{\infty} d\xi d\eta \text{Tr}(D(\alpha)D(\alpha')\rho D^\dagger(\alpha')) e^{i\xi X' + i\eta P'} \\ &= \frac{1}{(2\pi)^2} \int_{-\infty}^{\infty} \int_{-\infty}^{\infty} d\xi d\eta e^{\alpha\alpha'^* - \alpha^*\alpha'} \text{Tr}(D(\alpha)\rho) e^{i\xi X' + i\eta P'} , \end{aligned} \quad (8.515)$$

thus using

$$e^{\alpha\alpha'^* - \alpha^*\alpha'} e^{i\xi X' + i\eta P'} = e^{i\xi\left(X' - \frac{\alpha' + \alpha'^*}{\sqrt{2}}\right) + i\eta\left(P' - \left(\frac{\alpha' - \alpha'^*}{\sqrt{2}i}\right)\right)} \quad (8.516)$$

one finds that

$$W_\alpha(X', P') = W(X' - X'_{\alpha'}, P' - P'_{\alpha'}) , \quad (8.517)$$

where

$$X'_{\alpha'} = \frac{\alpha' + \alpha'^*}{\sqrt{2}} , \quad (8.518)$$

$$P'_{\alpha'} = \frac{\alpha' - \alpha'^*}{i\sqrt{2}} . \quad (8.519)$$

37. In general, the convolution theorem states that

$$\frac{1}{2\pi} \int_{-\infty}^{\infty} dX'' f(X'') g(X'') e^{iX'' P'} = \int_{-\infty}^{\infty} dP'' F(P'') G(P' - P'') , \quad (8.520)$$

where $F(P')$ ($G(P')$) is the Fourier transform of $f(X'')$ ($g(X'')$), i.e.

$$F(P') = \frac{1}{2\pi} \int_{-\infty}^{\infty} dX'' f(X'') e^{iX'' P'} , \quad (8.521)$$

$$G(P') = \frac{1}{2\pi} \int_{-\infty}^{\infty} dX'' g(X'') e^{iX'' P'} , \quad (8.522)$$

thus with the help of the identity

$$\frac{e^{-\left(\frac{P'}{\eta}\right)^2}}{\sqrt{\pi\eta}} = \frac{1}{2\pi} \int_{-\infty}^{\infty} dX'' e^{-\left(\frac{\eta X''}{2}\right)^2} e^{iX''P'} , \quad (8.523)$$

one finds that the reduced Wigner function $W_R(X', P')$ is related to $W(X', P')$ by [see Eq. (8.91)]

$$W_R(X', P') = \int_{-\infty}^{\infty} dP'' W(X', P'') \frac{e^{-\left(\frac{P'-P''}{\eta}\right)^2}}{\sqrt{\pi\eta}} . \quad (8.524)$$

As an example, for the case where $W(X', P')$ is normally distributed according to

$$W(X', P') = \frac{\exp\left(-\frac{X'^2 + P'^2}{\delta^2}\right)}{\pi\delta^2} , \quad (8.525)$$

where δ is a constant, Eq. (8.524) yields

$$W_R(X', P') = \frac{e^{-\left(\frac{X'}{\delta}\right)^2}}{\sqrt{\pi}\delta} \frac{e^{-\left(\frac{P'}{\sqrt{\eta^2 + \delta^2}}\right)^2}}{\sqrt{\pi}\sqrt{\eta^2 + \delta^2}} . \quad (8.526)$$

38. The normalization constant C is found with the help of Eq. (5.252) [see Eq. (8.93)]

$$\begin{aligned} 1 &= \langle \psi | \psi \rangle \\ &= 2|C|^2 \left(1 + e^{-2|\alpha|^2} \cos \theta_0\right) , \end{aligned} \quad (8.527)$$

where

$$\theta_0 = \text{Im} \left((\alpha_0 - \alpha) (\alpha_0 + \alpha)^* \right) . \quad (8.528)$$

With the help of Eqs. (5.35) and (5.41) one finds that

$$|\alpha_0 + \alpha\rangle = \zeta_0^{1/2} D(\alpha_0) |\alpha\rangle , \quad (8.529)$$

where

$$\zeta_0 = \exp(\alpha_0^* \alpha - \alpha_0 \alpha^*) , \quad (8.530)$$

and thus

$$\rho_0 = D(\alpha_0) \rho D^\dagger(\alpha_0) , \quad (8.531)$$

where the density operator ρ is given by

$$\rho = |C|^2 (\rho_{+,+} + \rho_{+,-} + \rho_{-,+} + \rho_{-,-}), \quad (8.532)$$

and where

$$\rho_{+,+} = |\alpha\rangle \langle \alpha|, \quad (8.533)$$

$$\rho_{+,-} = \zeta_0 |\alpha\rangle \langle -\alpha|, \quad (8.534)$$

$$\rho_{-,+} = \zeta_0^* |-\alpha\rangle \langle \alpha|, \quad (8.535)$$

$$\rho_{-,-} = |-\alpha\rangle \langle -\alpha|. \quad (8.536)$$

The Wigner function W_0 of the density operator ρ_0 can be expressed in terms of the Wigner function W of the density operator ρ [see Eqs. (8.517) and (8.531)]

$$W_0(X', P') = W(X'_r, P'_r), \quad (8.537)$$

where

$$X'_r = X' - \frac{\alpha_0 + \alpha_0^*}{\sqrt{2}}, \quad (8.538)$$

$$P'_r = P' - \frac{\alpha_0 - \alpha_0^*}{i\sqrt{2}}. \quad (8.539)$$

The density operator $W(X'_r, P'_r)$ is expressed as [see Eq. (8.532)]

$$W = |C|^2 (W_{+,+} + W_{+,-} + W_{-,+} + W_{-,-}), \quad (8.540)$$

where W_{σ_1, σ_2} is the Wigner function of $\rho_{\sigma_1, \sigma_2}$, and where $\sigma_1, \sigma_2 \in \{+, -\}$. With the help of Eq. (8.71) one finds that [see Eqs. (2.134) and (5.41)]

$$W_{+,+}(X'_r, P'_r) = \text{Tr}(\pi^{-1} \mathcal{P} | -Z'_r + \alpha \rangle \langle -Z'_r + \alpha |), \quad (8.541)$$

$$W_{+,-}(X'_r, P'_r) = \zeta_0 \zeta \text{Tr}(\pi^{-1} \mathcal{P} | -Z'_r + \alpha \rangle \langle -Z'_r - \alpha |), \quad (8.542)$$

$$W_{-,+}(X'_r, P'_r) = \zeta_0^* \zeta^* \text{Tr}(\pi^{-1} \mathcal{P} | -Z'_r - \alpha \rangle \langle -Z'_r + \alpha |), \quad (8.543)$$

$$W_{-,-}(X'_r, P'_r) = \text{Tr}(\pi^{-1} \mathcal{P} | -Z'_r - \alpha \rangle \langle -Z'_r - \alpha |), \quad (8.544)$$

where \mathcal{P} is the parity operator, Z'_r is given by

$$Z'_r = \frac{X'_r + iP'_r}{\sqrt{2}}, \quad (8.545)$$

and ζ is given by

$$\zeta = \exp(Z'_r{}^* \alpha - Z'_r \alpha^*). \quad (8.546)$$

The following holds

$$\text{Tr}(\pi^{-1} \mathcal{P} |\alpha_1\rangle \langle \alpha_2|) = \pi^{-1} \int_{-\infty}^{\infty} dx' \psi_{\alpha_1}(-x') \psi_{\alpha_2}^*(x'), \quad (8.547)$$

where $\psi_\alpha(x') = \langle x' | \alpha \rangle$ is the wave function of a of a coherent state $|\alpha\rangle$, and thus [see Eq. (5.51)]

$$\begin{aligned} \text{Tr}(\pi^{-1}\mathcal{P}|\alpha_1\rangle\langle\alpha_2|) &= \frac{1}{\pi^{3/2}} \exp(i\alpha'_2\alpha''_2 - i\alpha'_1\alpha''_1) \\ &\times \int_{-\infty}^{\infty} dX' \exp\left[-\frac{(-X' - \sqrt{2}\alpha'_1)^2}{2} - \frac{(X' - \sqrt{2}\alpha'_2)^2}{2} - i\sqrt{2}(\alpha''_1 + \alpha''_2)X'\right], \end{aligned} \quad (8.548)$$

where

$$\alpha_1 = \alpha'_1 + i\alpha''_1, \quad (8.549)$$

$$\alpha_2 = \alpha'_2 + i\alpha''_2, \quad (8.550)$$

and thus [see Eq. (5.149)]

$$\text{Tr}(\pi^{-1}\mathcal{P}|\alpha_1\rangle\langle\alpha_2|) = \pi^{-1} \exp\left(-\frac{|\alpha_1|^2 + |\alpha_2|^2 + 2\alpha_1\alpha_2^*}{2}\right). \quad (8.551)$$

With the help of the above results [see Eqs. (8.527), (8.537), (8.540), (8.545) and (8.551)] one obtains

$$W = \frac{e^{-2|Z_-|^2} + 2\text{Re}(\zeta_0\zeta^2)e^{-2|Z'_r|^2} + e^{-2|Z_+|^2}}{2\pi(1 + e^{-2|\alpha|^2}\cos\theta_0)}, \quad (8.552)$$

where

$$Z_\pm = Z'_r \pm \alpha. \quad (8.553)$$

39. With the help of Eqs. (5.37) and (5.252) one finds that

$$\begin{aligned} g^{(2)} &= \frac{1}{|C|^2} \frac{(\langle\alpha| + \langle-\alpha|)(|\alpha\rangle + |-\alpha\rangle)}{((\langle\alpha| - \langle-\alpha|)(|\alpha\rangle - |-\alpha\rangle))^2} \\ &= \frac{1}{|C|^2} \frac{1 + \exp(-2|\alpha|^2)}{2(1 - \exp(-2|\alpha|^2))^2}, \end{aligned} \quad (8.554)$$

where the normalization condition $\langle\psi|\psi\rangle = 1$ yields

$$|C|^2 = \frac{1}{2(1 + \exp(-2|\alpha|^2))}, \quad (8.555)$$

thus

$$\begin{aligned}
 g^{(2)} &= \left(\frac{1 + \exp(-2|\alpha|^2)}{1 - \exp(-2|\alpha|^2)} \right)^2 \\
 &= \coth^2(|\alpha|^2) .
 \end{aligned}
 \tag{8.556}$$

40. The dynamics along the x direction is governed by the Hamiltonian \mathcal{H}_x of a harmonic oscillator

$$\mathcal{H}_x = \frac{p_x^2}{2m} + \frac{1}{2}m\omega^2 x^2 .
 \tag{8.557}$$

By symmetry $\langle x \rangle = 0$. The expectation value $\langle x^2 \rangle$ was calculated in Eq. (8.259) and found to be given by

$$\langle x^2 \rangle = \frac{1}{m\omega^2} \frac{\hbar\omega}{2} \coth\left(\frac{\hbar\omega\beta}{2}\right) .
 \tag{8.558}$$

41. The unitary time evolution of ρ , corresponding to the case where no measurements are performed (i.e. no collapse), is given by [see Eq. (8.31)]

$$\rho(t) = u(t; t_0) \rho_0 u^\dagger(t; t_0) ,
 \tag{8.559}$$

where $u(t; t_0)$ is the time evolution operator from time t_0 to time t , and where $\rho_0 = \rho(t_0)$ is the density operator at initial time t_0 . Each of the two observables A_1 and A_2 can be expressed in terms of its eigenvalues $a_{n,k}$ and in terms of the projection operators $P_{n,k}$ onto the corresponding subspaces as

$$A_n = \sum_k a_{n,k} P_{n,k} ,
 \tag{8.560}$$

where the projection operators $P_{n,k}$ are given by [see Eq. (2.80)]

$$P_{n,k} = \prod_{k' \neq k} \frac{A_n - a_{n,k'}}{a_{n,k} - a_{n,k'}} .
 \tag{8.561}$$

The eigenvalues of the Hermitian projection operator $P_{n,k}$ are 0 and 1 and the following holds $P_{n,k} P_{n,k'} = P_{n,k'} P_{n,k} = P_{n,k} \delta_{k,k'}$. The closure relation is given by [see Eq. (2.67)]

$$\sum_k P_{n,k} = 1 .
 \tag{8.562}$$

- a) The probability $p_1(k_1)$ that the measurement at time t_1 of the observable A_1 yields the value a_{1,k_1} , namely, the probability that $\mathcal{A}_1 = a_{1,k_1}$, is given by [see Eq. (8.10)]

$$p_1(k_1) = \text{Tr}(P_{1,k_1}\rho(t_1)) . \quad (8.563)$$

Using Eq. (8.559) and the notation

$$\bar{O} = \text{Tr}(O\rho_0) , \quad (8.564)$$

where O is an operator, one finds that the probability $p_1(k_1)$ can be expressed as

$$p_1(k_1) = \overline{P_{1,k_1}(t_1)} , \quad (8.565)$$

where $P_{1,k_1}(t_1) = u^\dagger(t_1; t_0) P_{1,k_1} u(t_1; t_0)$ is the Heisenberg representation of the projection operator P_{1,k_1} .

- b) According to the collapse postulate the first measurement at time t_1 disturbs the unitary time evolution given by Eq. (8.559) of the density operator ρ . Given that a_{1,k_1} was obtained in the first measurement of \mathcal{A}_1 at time t_1 , the density operator $\rho(t_1) = u(t_1; t_0) \rho_0 u^\dagger(t_1; t_0)$ collapses and becomes $\rho_{k_1}(t_1)$, where

$$\rho_{k_1}(t_1) = \frac{P_{1,k_1}\rho(t_1)P_{1,k_1}}{p_1(k_1)} . \quad (8.566)$$

By assuming unitary time evolution from time t_1 to time t_2 one finds that the conditional probability $p(k_2|k_1)$ that $\mathcal{A}_2 = a_{2,k_2}$, given that $\mathcal{A}_1 = a_{1,k_1}$, is given by

$$p(k_2|k_1) = \frac{\overline{P_{1,k_1}(t_1)P_{2,k_2}(t_2)P_{1,k_1}(t_1)}}{p_1(k_1)} , \quad (8.567)$$

where $P_{2,k_2}(t_2) = u^\dagger(t_2; t_0) P_{2,k_2} u(t_2; t_0)$. The last result implies that the joint probability $p(k_1, k_2) = p_1(k_1)p(k_2|k_1)$, namely the probability that $\mathcal{A}_1 = a_{1,k_1}$ and $\mathcal{A}_2 = a_{2,k_2}$, is given by

$$p(k_1, k_2) = \overline{P_{1,k_1}(t_1)P_{2,k_2}(t_2)P_{1,k_1}(t_1)} . \quad (8.568)$$

Furthermore, the probability $p_2(k_2)$ that $\mathcal{A}_2 = a_{2,k_2}$ is given by

$$p_2(k_2) = \text{Tr}(P_{2,k_2}u(t_2; t_1)\rho_p u^\dagger(t_2; t_1)) , \quad (8.569)$$

where the projected density operator ρ_p is given by

$$\rho_p = \sum_{k'_1} P_{1,k'_1}\rho(t_1)P_{1,k'_1} . \quad (8.570)$$

- c) The assumption that $[\rho_0, \mathcal{A}_1(t_1)] = 0$ implies that

$$[\rho_0, P_{1,k_1}(t_1)] = 0 \quad (8.571)$$

for all k_1 . Thus Eq. (8.570) for the present case becomes $\rho_p = \rho(t_1)$. In other words, the non unitary transformation (collapse) that the density operator undergoes at time t_1 according to the collapse postulates leaves ρ unchanged.

d) The assumption that $[A_2(t_2), A_1(t_1)] = 0$ implies that

$$[P_{2,k_2}(t_2), P_{1,k_1}(t_1)] = 0$$

for all k_1 and all k_2 , and therefore, as can be seen from Eq. (8.568), the following holds

$$p(k_1, k_2) = \overline{P_{1,k_1}(t_1) P_{2,k_2}(t_2)}, \quad (8.572)$$

hence [see Eq. (8.562)]

$$p_2(k_2) = \sum_{k'_1} p(k'_1, k_2) = \overline{P_{2,k_2}(t_2)}, \quad (8.573)$$

thus also for this case the collapse at time t_1 does not affect the measurement at the later time t_2 [compare with Eq. (8.565)]. As is shown below, the condition $[A_2(t_2), A_1(t_1)] = 0$ is commonly satisfied. In general, the following holds

$$\begin{aligned} & [A_2(t_2), A_1(t_1)] \\ &= u^\dagger(t_1; t_0) [u^\dagger(t_2; t_1) A_2 u(t_2; t_1), A_1] u(t_1; t_0). \end{aligned} \quad (8.574)$$

Consider a system containing two distinct subsystems, and assume the case where the observable A_1 depends only on the degrees of freedom of the first subsystem, whereas A_2 depends only on the degrees of freedom of the second one. This assumption implies that $[A_2, A_1] = 0$. Furthermore, assume that there is no interaction between the two different subsystems during the time interval $t \in (t_1, t_2)$ between the two measurements (note that interaction between the subsystems before or after this time period is not excluded). The later assumption implies, as can be seen from Eq. (8.574), that the condition $[A_2(t_2), A_1(t_1)] = 0$ is expected to hold.

42. In general, for any smooth function $f(\rho)$ of ρ the following holds

$$f(\rho(t)) = u(t, t_0) f(\rho(t_0)) u^\dagger(t, t_0). \quad (8.575)$$

This can be shown by Taylor expanding the function $f(\rho)$ as a power series

$$f(\rho(t)) = \sum_{n=0}^{\infty} a_n (\rho(t))^n, \quad (8.576)$$

using Eq. (8.31) and the fact that $u^\dagger(t, t_0) u(t, t_0) = 1$, i.e. the unitarity of the time evolution operator. By using this result for the function $\rho \log \rho$ together with the general identity $\text{Tr}(XY) = \text{Tr}(YX)$ [see Eq. (2.134)] one easily finds that σ is time independent. This somewhat surprising result suggests that the time evolution generated by the Schrödinger equation corresponds to a reversible process, for which entropy is preserved.

43. Using the definition of the Pauli matrices (6.137) one finds that

$$\rho = \frac{1}{2} \begin{pmatrix} 1 + k_z & k_x - ik_y \\ k_x + ik_y & 1 - k_z \end{pmatrix}. \quad (8.577)$$

a) Let λ_{\pm} be the two eigenvalues of ρ . The following holds

$$\text{Tr}(\rho) = \lambda_+ + \lambda_- = 1, \quad (8.578)$$

and

$$\text{Det}(\rho) = \lambda_+ \lambda_- = (1 - \mathbf{k}^2) / 4, \quad (8.579)$$

where $\mathbf{k}^2 = k_x^2 + k_y^2 + k_z^2$. Thus

$$\lambda_{\pm} = \frac{1 \pm |\mathbf{k}|}{2}, \quad (8.580)$$

and therefore

$$\sigma = f(|\mathbf{k}|), \quad (8.581)$$

where

$$f(x) = -\frac{1-x}{2} \log \frac{1-x}{2} - \frac{1+x}{2} \log \frac{1+x}{2}. \quad (8.582)$$

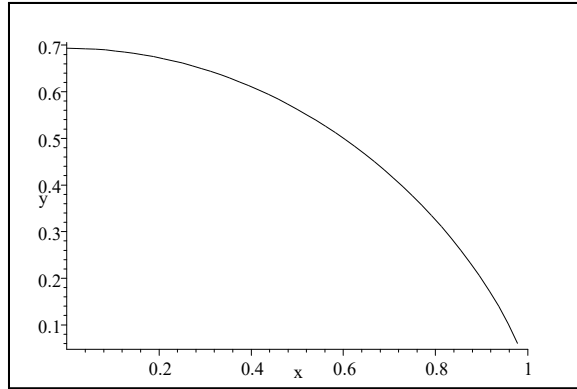

The function $f(x) = -\frac{1-x}{2} \log \frac{1-x}{2} - \frac{1+x}{2} \log \frac{1+x}{2}$.

b) As can be seen from Eq. (8.297), after the measurement ρ becomes diagonal in the basis of eigenvectors of the measured observable, namely, after the measurement the density matrix is given by

$$\rho_c = \frac{1}{2} \begin{pmatrix} 1 + k_z & 0 \\ 0 & 1 - k_z \end{pmatrix}, \quad (8.583)$$

and thus the entropy after the measurement is

$$\sigma_c = f(k_z) = -\frac{1-k_z}{2} \log \frac{1-k_z}{2} - \frac{1+k_z}{2} \log \frac{1+k_z}{2}. \quad (8.584)$$

44. With the help of Eq. (6.138) one finds for arbitrary vectors \mathbf{a} and \mathbf{b} that

$$[\boldsymbol{\sigma} \cdot \mathbf{a}, \boldsymbol{\sigma} \cdot \mathbf{b}] = 2i\boldsymbol{\sigma} \cdot (\mathbf{a} \times \mathbf{b}) , \quad (8.585)$$

thus Eq. (8.29) yields [compare with Eq. (6.198)]

$$\frac{d\mathbf{k}}{dt} = -2\mathbf{k} \times \boldsymbol{\omega} . \quad (8.586)$$

45. The matrix representation of the density operator ρ_0 can be expressed by

$$\rho_0 = \mathcal{R}(\gamma \hat{\mathbf{n}}_0) , \quad (8.587)$$

where

$$\mathcal{R}(\mathbf{v}) = \frac{1 + \mathbf{v} \cdot \boldsymbol{\sigma}}{2} . \quad (8.588)$$

To ensure that ρ_0 is Hermitian both the number γ and the unit vector $\hat{\mathbf{n}}_0$ are required to be real.

a) The following holds [note that $\text{Tr}(1) = 2$ and $\text{Tr}(\mathbf{v} \cdot \boldsymbol{\sigma}) = 0$]

$$\text{Tr}(\mathcal{R}(\mathbf{v})) = \text{Tr}\left(\frac{1 + \mathbf{v} \cdot \boldsymbol{\sigma}}{2}\right) = 1 , \quad (8.589)$$

and [see Eq. (6.138)]

$$\text{Tr}(\mathcal{R}(\mathbf{v}_1) \mathcal{R}(\mathbf{v}_2)) = \frac{1 + \mathbf{v}_1 \cdot \mathbf{v}_2}{2} , \quad (8.590)$$

thus, the matrix ρ_0 represents a pure state when $\gamma = 1$, whereas it represents a mixed state when $0 \leq \gamma < 1$.

b) The matrix representations of the projection operator $P(\hat{\mathbf{n}})$ corresponding to the state where the spin points in the $\hat{\mathbf{n}}$ direction, where $\hat{\mathbf{n}}$ is a unit vector, is given by

$$P(\hat{\mathbf{n}}) = \mathcal{R}(\hat{\mathbf{n}}) , \quad (8.591)$$

thus, the probability p to find the spin pointing in the $\hat{\mathbf{n}}$ direction is given by

$$p = \text{Tr}(\rho_0 P(\hat{\mathbf{n}})) = \text{Tr}(\mathcal{R}(\gamma \hat{\mathbf{n}}_0) \mathcal{R}(\hat{\mathbf{n}})) , \quad (8.592)$$

thus [see Eq. (8.590)]

$$p = \frac{1 + \gamma \hat{\mathbf{n}}_0 \cdot \hat{\mathbf{n}}}{2} . \quad (8.593)$$

For the current case $\hat{\mathbf{n}} = \hat{\mathbf{n}}_1$, hence

$$p = \frac{1 + \gamma \hat{\mathbf{n}}_0 \cdot \hat{\mathbf{n}}_1}{2} . \quad (8.594)$$

- c) The first measurement causes a collapse of the density matrix $\rho_0 \rightarrow \rho_p$, where ρ_p is given by [see Eqs. (6.138), (8.297) and recall vector identity $\mathbf{A} \times (\mathbf{B} \times \mathbf{A}) = (\mathbf{A} \cdot \mathbf{A}) \mathbf{B} - (\mathbf{A} \cdot \mathbf{B}) \mathbf{A}$]

$$\begin{aligned}
\rho_p &= \mathcal{R}(\hat{\mathbf{n}}_1) \mathcal{R}(\gamma \hat{\mathbf{n}}_0) \mathcal{R}(\hat{\mathbf{n}}_1) \\
&\quad + \mathcal{R}(-\hat{\mathbf{n}}_1) \mathcal{R}(\gamma \hat{\mathbf{n}}_0) \mathcal{R}(-\hat{\mathbf{n}}_1) \\
&= \frac{1 + \hat{\mathbf{n}}_1 \cdot \boldsymbol{\sigma}}{2} \frac{1 + \gamma \hat{\mathbf{n}}_0 \cdot \boldsymbol{\sigma}}{2} \frac{1 + \hat{\mathbf{n}}_1 \cdot \boldsymbol{\sigma}}{2} \\
&\quad + \frac{1 - \hat{\mathbf{n}}_1 \cdot \boldsymbol{\sigma}}{2} \frac{1 + \gamma \hat{\mathbf{n}}_0 \cdot \boldsymbol{\sigma}}{2} \frac{1 - \hat{\mathbf{n}}_1 \cdot \boldsymbol{\sigma}}{2} \\
&= \frac{1 + \gamma \hat{\mathbf{n}}_0 \cdot \boldsymbol{\sigma} + (\hat{\mathbf{n}}_1 \cdot \boldsymbol{\sigma})(1 + \gamma \hat{\mathbf{n}}_0 \cdot \boldsymbol{\sigma})(\hat{\mathbf{n}}_1 \cdot \boldsymbol{\sigma})}{4} \\
&= \frac{1 + \gamma (\hat{\mathbf{n}}_0 \cdot \hat{\mathbf{n}}_1) (\hat{\mathbf{n}}_1 \cdot \boldsymbol{\sigma})}{2} \\
&= \mathcal{R}(\gamma (\hat{\mathbf{n}}_0 \cdot \hat{\mathbf{n}}_1) \hat{\mathbf{n}}_1) ,
\end{aligned} \tag{8.595}$$

thus, the probability p_2 for the second measurement is given by [see Eq. (8.593)]

$$p_2 = \frac{1 + \gamma (\hat{\mathbf{n}}_0 \cdot \hat{\mathbf{n}}_1) (\hat{\mathbf{n}}_1 \cdot \hat{\mathbf{n}}_2)}{2} . \tag{8.596}$$

For the case where no collapse has occurred after the first measurement the probability is given by [see Eq. (8.593)]

$$\tilde{p}_2 = \frac{1 + \gamma \hat{\mathbf{n}}_0 \cdot \hat{\mathbf{n}}_2}{2} , \tag{8.597}$$

thus the collapse has no effect provided that $\hat{\mathbf{n}}_1 = \hat{\mathbf{n}}_0$.

46. First, consider a general functional $g(\rho)$ of the density operator having the form

$$g(\rho) = \text{Tr}(f(\rho)) , \tag{8.598}$$

where the function $f(\rho)$ can be Taylor expanded as a power series

$$f(\rho) = \sum_{k=0}^{\infty} a_k \rho^k , \tag{8.599}$$

and where a_k are complex constants. Consider an infinitesimal change in the density operator $\rho \rightarrow \rho + d\rho$. To first order in $d\rho$ the corresponding change dg in the functional $g(\rho)$ can be expressed as

$$\begin{aligned}
 dg &= g(\rho + d\rho) - g(\rho) \\
 &= \text{Tr} \left(\sum_{k=0}^{\infty} a_k [(\rho + d\rho)^k - \rho^k] \right) \\
 &= \text{Tr} \left[\sum_{k=0}^{\infty} a_k \left(\underbrace{\rho^{k-1} d\rho + \rho^{k-2} (d\rho) \rho + \rho^{k-3} (d\rho) \rho^2 + \dots}_{k \text{ terms}} \right) \right] + O((d\rho)^2) .
 \end{aligned} \tag{8.600}$$

By exploiting the general identity $\text{Tr}(XY) = \text{Tr}(YX)$ the above result can be simplified (note that generally ρ needs not to commute with $d\rho$)

$$dg = \text{Tr} \left[\left(\sum_{k=0}^{\infty} a_k k \rho^{k-1} \right) d\rho \right] + O((d\rho)^2) , \tag{8.601}$$

thus to first order in $d\rho$ the following holds

$$dg = \text{Tr} \left(\frac{df}{d\rho} d\rho \right) . \tag{8.602}$$

In the above expression the term $df/d\rho$ is calculated by simply taking the derivative of the function $f(x)$ (where x is considered to be a number) and substituting $x = \rho$. Alternatively, the change dg can be expressed in terms of the infinitesimal change $d\rho_{nm}$ in the matrix elements ρ_{nm} of ρ . To first order in the infinitesimal variables $d\rho_{nm}$ one has

$$dg = \sum_{n,m} \frac{\partial g}{\partial \rho_{nm}} d\rho_{nm} . \tag{8.603}$$

It is convenient to rewrite the above expression as

$$dg = \bar{\nabla} g \cdot \bar{d\rho} , \tag{8.604}$$

where the vector elements of the nabla operator $\bar{\nabla}$ and of $\bar{d\rho}$ are given by

$$(\bar{\nabla})_{n,m} = \frac{\partial}{\partial \rho_{nm}} , \tag{8.605}$$

and

$$(\bar{d\rho})_{n,m} = d\rho_{nm} . \tag{8.606}$$

Thus, to first order one has

$$d\sigma = \bar{\nabla} \sigma \cdot \bar{d\rho} , \tag{8.607}$$

and

$$dg_l = \bar{\nabla} g_l \cdot \bar{d\rho} , \tag{8.608}$$

where $l = 0, 1, 2, \dots, L$.

- a) In general, the technique of Lagrange multipliers is very useful for finding stationary points of a function, when constraints are applied. A stationary point of σ occurs iff for every small change $\overline{d\rho}$, which is orthogonal to all vectors $\overline{\nabla}g_0, \overline{\nabla}g_1, \overline{\nabla}g_2, \dots, \overline{\nabla}g_L$ (i.e. a change which does not violate the constraints) one has

$$0 = d\sigma = \overline{\nabla}\sigma \cdot \overline{d\rho} . \quad (8.609)$$

This condition is fulfilled only when the vector $\overline{\nabla}\sigma$ belongs to the subspace spanned by the vectors $\{\overline{\nabla}g_0, \overline{\nabla}g_1, \overline{\nabla}g_2, \dots, \overline{\nabla}g_L\}$. In other words, only when

$$\overline{\nabla}\sigma = \xi_0 \overline{\nabla}g_0 + \xi_1 \overline{\nabla}g_1 + \xi_2 \overline{\nabla}g_2 + \dots + \xi_L \overline{\nabla}g_L , \quad (8.610)$$

where the numbers $\xi_0, \xi_1, \dots, \xi_L$, which are called Lagrange multipliers, are constants. By multiplying by $\overline{d\rho}$ the last result becomes

$$d\sigma = \xi_0 dg_0 + \xi_1 dg_1 + \xi_2 dg_2 + \dots + \xi_L dg_L . \quad (8.611)$$

Using Eqs. (8.602), (8.103), (8.105) and (8.106) one finds that

$$d\sigma = -\text{Tr}((1 + \log \rho) d\rho) , \quad (8.612)$$

$$dg_0 = \text{Tr}(d\rho) , \quad (8.613)$$

$$dg_l = \text{Tr}(X_l d\rho) , \quad (8.614)$$

thus

$$0 = \text{Tr} \left[\left(1 + \log \rho + \xi_0 + \sum_{l=1}^L \xi_l X_l \right) d\rho \right] . \quad (8.615)$$

The requirement that the last identity holds for any $d\rho$ implies that

$$1 + \log \rho + \xi_0 + \sum_{l=1}^L \xi_l X_l = 0 , \quad (8.616)$$

thus

$$\rho = e^{-1-\xi_0} \exp \left(- \sum_{l=1}^L \xi_l X_l \right) . \quad (8.617)$$

The Lagrange multipliers $\xi_0, \xi_1, \dots, \xi_L$ can be determined from Eqs. (8.105) and (8.106). The first constraint (8.105) is satisfied by replacing the factor $e^{-1-\xi_0}$ by the inverse of the partition function Z

$$\rho = \frac{1}{Z} \exp \left(- \sum_{l=1}^L \xi_l X_l \right) . \quad (8.618)$$

where

$$Z = \text{Tr} \left(\exp \left(- \sum_{l=1}^L \xi_l X_l \right) \right) . \quad (8.619)$$

As can be seen from the above expression for Z , the following holds

$$\langle X_l \rangle = - \frac{\partial \log Z}{\partial \xi_l} . \quad (8.620)$$

The entropy $\sigma = - \text{Tr} (\rho \log \rho) = - \langle \log \rho \rangle$ [see Eq. (8.97)] is related to Z by [see Eqs. (8.618) and (8.619)]

$$\sigma = \log Z + \sum_{l=1}^L \xi_l \langle X_l \rangle . \quad (8.621)$$

- b) For the case of a microcanonical ensemble Eq. (8.618) yields $\rho = 1/Z$, i.e. ρ is proportional to the identity operator.
 c) For the case of a canonical ensemble Eq. (8.618) yields

$$\rho_c = \frac{1}{Z_c} e^{-\beta \mathcal{H}} , \quad (8.622)$$

where the canonical partition function Z_c is given by

$$Z_c = \text{Tr} (e^{-\beta \mathcal{H}}) , \quad (8.623)$$

and where β labels the Lagrange multiplier associated with the given expectation value $\langle \mathcal{H} \rangle$. By solving Eq. (8.106), which for this case is given by [see also Eq. (8.620)]

$$\langle \mathcal{H} \rangle = \frac{1}{Z_c} \text{Tr} (\mathcal{H} e^{-\beta \mathcal{H}}) = - \frac{\partial \log Z_c}{\partial \beta} . \quad (8.624)$$

the Lagrange multiplier β can be determined. Note that the temperature T is defined by the relation $\beta = 1/(k_B T)$, where k_B is the Boltzmann's constant.

- d) For the case of a grandcanonical ensemble Eq. (8.618) yields

$$\rho_{\text{gc}} = \frac{1}{Z_{\text{gc}}} e^{-\beta \mathcal{H} + \beta \mu N} , \quad (8.625)$$

where the grandcanonical partition function Z_{gc} is given by

$$Z_{\text{gc}} = \text{Tr} (e^{-\beta \mathcal{H} + \beta \mu N}) . \quad (8.626)$$

Here the Lagrange multiplier associated with the given expectation value $\langle N \rangle$ is given by $-\beta \mu$, where μ is known as the chemical potential. The average energy $\langle \mathcal{H} \rangle$ is given by

$$\begin{aligned}
\langle \mathcal{H} \rangle &= \text{Tr} (\mathcal{H} \rho_{\text{gc}}) \\
&= \frac{\text{Tr} (\mathcal{H} e^{-\beta(\mathcal{H} - \mu N)})}{\text{Tr} (e^{-\beta(\mathcal{H} - \mu N)})} \\
&= -\frac{\text{Tr} (- (\mathcal{H} - \mu N) e^{-\beta(\mathcal{H} - \mu N)})}{\text{Tr} (e^{-\beta(\mathcal{H} - \mu N)})} + \frac{\mu}{\beta} \frac{\text{Tr} (N e^{-\beta\mathcal{H} + \beta\mu N})}{\text{Tr} (e^{-\beta\mathcal{H} + \beta\mu N})},
\end{aligned}$$

thus

$$\langle \mathcal{H} \rangle = - \left(\frac{\partial \log Z_{\text{gc}}}{\partial \beta} \right)_{\mu} + \frac{\mu}{\beta} \left(\frac{\partial \log Z_{\text{gc}}}{\partial \mu} \right)_{\beta}. \quad (8.627)$$

Similarly, the average number of particles $\langle N \rangle$ is given by

$$\langle N \rangle = \text{Tr} (N \rho_{\text{gc}}) = \frac{\text{Tr} (N e^{-\beta\mathcal{H} + \beta\mu N})}{\text{Tr} (e^{-\beta\mathcal{H} + \beta\mu N})}. \quad (8.628)$$

In terms of the fugacity λ , which is defined by

$$\lambda = e^{\beta\mu}, \quad (8.629)$$

$\langle N \rangle$ can be expressed as

$$\langle N \rangle = \lambda \frac{\partial \log Z_{\text{gc}}}{\partial \lambda}. \quad (8.630)$$

47. Let $\{|n'\rangle\}$ ($\{|n''\rangle\}$) be an orthonormal basis made of eigenvectors of ρ' (ρ''), and let $\{p'_{n'}\}$ ($\{p''_{n''}\}$) be the corresponding set of eigenvalues. The following holds

$$\rho' |n'\rangle = p'_{n'} |n'\rangle, \quad (8.631)$$

$$\rho'' |n''\rangle = p''_{n''} |n''\rangle, \quad (8.632)$$

and [see Eq. (8.12)]

$$\sum_{n'} p'_{n'} = \sum_{n''} p''_{n''} = 1, \quad (8.633)$$

and [see Eq. (8.20)]

$$0 \leq p'_{n'} \leq 1, \quad (8.634)$$

$$0 \leq p''_{n''} \leq 1. \quad (8.635)$$

- a) The following holds [see Eq. (2.23)]

$$\begin{aligned}
 S(\rho' \parallel \rho'') &= \sum_{n'} \langle n' | (\rho' (\log \rho' - \log \rho'')) | n' \rangle \\
 &= \sum_{n'} (p'_{n'} \log p'_{n'} - p'_{n'} \langle n' | \log \rho'' | n' \rangle) \\
 &= \sum_{n'} \left(p'_{n'} \log p'_{n'} - p'_{n'} \langle n' | \sum_{n''} |n''\rangle \langle n''| \log \rho'' | n' \rangle \right) \\
 &= \sum_{n'} p'_{n'} \left(\log p'_{n'} - \sum_{n''} |\langle n' | n'' \rangle|^2 \log p''_{n''} \right) .
 \end{aligned} \tag{8.636}$$

The function $-\log x$ is convex, thus

$$\begin{aligned}
 S(\rho' \parallel \rho'') &\geq \sum_{n'} p'_{n'} \left(\log p'_{n'} - \log \left(\sum_{n''} |\langle n' | n'' \rangle|^2 p''_{n''} \right) \right) \\
 &= - \sum_{n'} p'_{n'} \log \frac{\sum_{n''} |\langle n' | n'' \rangle|^2 p''_{n''}}{p'_{n'}} .
 \end{aligned} \tag{8.637}$$

Using the inequality (for $x > 0$)

$$x - 1 \geq \log x , \tag{8.638}$$

one finds that

$$\begin{aligned}
 S(\rho' \parallel \rho'') &\geq \sum_{n'} p'_{n'} \left(1 - \frac{\sum_{n''} |\langle n' | n'' \rangle|^2 p''_{n''}}{p'_{n'}} \right) \\
 &= 1 - \sum_{n''} p''_{n''} \sum_{n'} |\langle n' | n'' \rangle|^2 \\
 &= 1 - \sum_{n''} p''_{n''} \\
 &= 0 .
 \end{aligned} \tag{8.639}$$

b) The Bogoliubov inequality (8.109) is obtained using the relative entropy positivity (8.108).

48. The Hamiltonian can be expressed as a function of the operators p and x as

$$\mathcal{H}(p, x) = \frac{p^2}{2m} + V(x) . \tag{8.640}$$

Evaluating Z_c according to Eq. (8.623) by tracing over momentum states yields

$$\begin{aligned}
Z_c &= \text{Tr} (e^{-\beta\mathcal{H}}) \\
&= \int dp' \langle p' | e^{-\beta\mathcal{H}} | p' \rangle \\
&= \int dx' \int dp' \langle p' | x' \rangle \langle x' | e^{-\beta\mathcal{H}} | p' \rangle .
\end{aligned} \tag{8.641}$$

In the classical limit the parameter β , which is inversely proportional to the temperature, is considered as small. Using Eq. (12.121) from chapter 12, which states that for general operators A and B the following holds

$$e^{\beta(A+B)} = e^{\beta A} e^{\beta B} + O(\beta^2) , \tag{8.642}$$

one finds that

$$e^{-\beta\mathcal{H}} = e^{-\beta V(x)} e^{-\beta \frac{p^2}{2m}} + O(\beta^2) . \tag{8.643}$$

This result together with Eq. (3.52), which is given by

$$\langle x' | p' \rangle = \frac{1}{\sqrt{2\pi\hbar}} \exp\left(\frac{ip'x'}{\hbar}\right) , \tag{8.644}$$

yield in the classical limit

$$\begin{aligned}
Z_c &= \int dx' \int dp' \langle p' | x' \rangle \langle x' | e^{-\beta V(x)} e^{-\beta \frac{p^2}{2m}} | p' \rangle \\
&= \int dx' \int dp' e^{-\beta V(x')} e^{-\beta \frac{p'^2}{2m}} \langle p' | x' \rangle \langle x' | p' \rangle \\
&= \frac{1}{2\pi\hbar} \int dx' \int dp' e^{-\beta\mathcal{H}(p',x')} .
\end{aligned} \tag{8.645}$$

Note that this result can be also obtained by taking the limit $\hbar \rightarrow 0$, for which the operator x and p can be considered as commuting operators (recall that $[x, p] = i\hbar$), and consequently in this limit $e^{-\beta\mathcal{H}}$ can be factored in the same way [see Eq. (8.643)].

49. The density operator ρ before the measurement is given by

$$\rho = p_1 |\alpha_1\rangle \langle \alpha_1| + p_2 |\alpha_2\rangle \langle \alpha_2| . \tag{8.646}$$

a) The observable P_β is a projection, thus the possible values of B are 0 and 1. The following holds

$$\langle B \rangle = \text{Tr} (\rho B) = p_1 |\langle \beta | \alpha_1 \rangle|^2 + p_2 |\langle \beta | \alpha_2 \rangle|^2 , \tag{8.647}$$

and thus

$$p(B=1) = \langle B \rangle , \tag{8.648}$$

and

$$p(B=0) = 1 - \langle B \rangle . \tag{8.649}$$

b) Recall that in general for events C_1 and C_2

$$p(C_1 \cap C_2) = p(C_1)p(C_2|C_1) = p(C_2)p(C_1|C_2) , \quad (8.650)$$

where $p(C)$ denotes the probability that event C occurs, $p(C_1 \cap C_2)$ is the probability that both events C_1 and C_2 occur and $p(C_2|C_1)$ ($p(C_1|C_2)$) is the conditional probability that event C_2 (C_1) occurs given that event C_1 (C_2) has occurred. Thus

$$p(|\alpha\rangle = |\alpha_1\rangle | B = 0) = \frac{p(|\alpha\rangle = |\alpha_1\rangle)p(B = 0 | |\alpha\rangle = |\alpha_1\rangle)}{p(B = 0)} ,$$

$$p(|\alpha\rangle = |\alpha_1\rangle | B = 1) = \frac{p(|\alpha\rangle = |\alpha_1\rangle)p(B = 1 | |\alpha\rangle = |\alpha_1\rangle)}{p(B = 1)} ,$$

$$p(|\alpha\rangle = |\alpha_2\rangle | B = 0) = \frac{p(|\alpha\rangle = |\alpha_2\rangle)p(B = 0 | |\alpha\rangle = |\alpha_2\rangle)}{p(B = 0)} ,$$

$$p(|\alpha\rangle = |\alpha_2\rangle | B = 1) = \frac{p(|\alpha\rangle = |\alpha_2\rangle)p(B = 1 | |\alpha\rangle = |\alpha_2\rangle)}{p(B = 1)} ,$$

and therefore

$$p(|\alpha\rangle = |\alpha_1\rangle | B = 0) = \frac{p_1(1 - g_1)}{1 - p_1g_1 - p_2g_2} , \quad (8.651)$$

$$p(|\alpha\rangle = |\alpha_1\rangle | B = 1) = \frac{p_1g_1}{p_1g_1 + p_2g_2} , \quad (8.652)$$

$$p(|\alpha\rangle = |\alpha_2\rangle | B = 0) = \frac{p_2(1 - g_2)}{1 - p_1g_1 - p_2g_2} , \quad (8.653)$$

$$p(|\alpha\rangle = |\alpha_2\rangle | B = 1) = \frac{p_2g_2}{p_1g_1 + p_2g_2} , \quad (8.654)$$

where

$$g_1 = |\langle \beta | \alpha_1 \rangle|^2 , \quad (8.655)$$

$$g_2 = |\langle \beta | \alpha_2 \rangle|^2 . \quad (8.656)$$

Note that the following holds (recall that $p_2 = 1 - p_1$)

$$p(|\alpha\rangle = |\alpha_1\rangle | B = 0) + p(|\alpha\rangle = |\alpha_2\rangle | B = 0) = 1 , \quad (8.657)$$

$$p(|\alpha\rangle = |\alpha_1\rangle | B = 1) + p(|\alpha\rangle = |\alpha_2\rangle | B = 1) = 1 , \quad (8.658)$$

and

$$\frac{p(|\alpha\rangle = |\alpha_1\rangle | B = 0)}{p(|\alpha\rangle = |\alpha_2\rangle | B = 0)} = \frac{p_1(1 - g_1)}{p_2(1 - g_2)} , \quad (8.659)$$

$$\frac{p(|\alpha\rangle = |\alpha_1\rangle | B = 1)}{p(|\alpha\rangle = |\alpha_2\rangle | B = 1)} = \frac{p_1g_1}{p_2g_2} . \quad (8.660)$$

c) The following holds

$$\begin{aligned} S_0 &= -p(|\alpha\rangle = |\alpha_1\rangle | B = 0) \log(p(|\alpha\rangle = |\alpha_1\rangle | B = 0)) \\ &\quad -p(|\alpha\rangle = |\alpha_2\rangle | B = 0) \log(p(|\alpha\rangle = |\alpha_2\rangle | B = 0)) , \end{aligned} \quad (8.661)$$

and

$$S_1 = -p(|\alpha\rangle = |\alpha_1\rangle |B = 1\rangle \log(p(|\alpha\rangle = |\alpha_1\rangle |B = 1\rangle)) \\ -p(|\alpha\rangle = |\alpha_2\rangle |B = 1\rangle \log(p(|\alpha\rangle = |\alpha_2\rangle |B = 1\rangle)) , \quad (8.662)$$

thus [see Eqs. (8.648) and (8.649)]

$$S_f = p(B = 0) S_0 + p(B = 1) S_1 = S_{\alpha B} - S_B , \quad (8.663)$$

where $S_{\alpha B}$, given by

$$S_{\alpha B} = \sum_{i=1,2} \sum_{B'=0,1} p(|\alpha\rangle = |\alpha_i\rangle \cap B = B') \log(p(|\alpha\rangle = |\alpha_i\rangle \cap B = B')) , \quad (8.664)$$

and S_B is given by

$$S_B = \sum_{B'=0,1} p(B = B') \log(p(B = B')) , \quad (8.665)$$

and thus

$$S_f - S_i = S_{\alpha B} - S_B - S_i , \quad (8.666)$$

or

$$S_f - S_i = \sum_{i=1,2} \sum_{B'=0,1} p(|\alpha\rangle = |\alpha_i\rangle \cap B = B') \log\left(\frac{p(|\alpha\rangle = |\alpha_i\rangle \cap B = B')}{p(|\alpha\rangle = |\alpha_i\rangle) p(B = B')}\right) \\ = \sum_{i=1,2} \sum_{B'=0,1} p(|\alpha\rangle = |\alpha_i\rangle \cap B = B') \log\left(\frac{p(|\alpha\rangle = |\alpha_i\rangle |B = B')}{p(|\alpha\rangle = |\alpha_i\rangle)}\right) . \quad (8.667)$$

With the help of Eqs. (8.651), (8.652), (8.653) and (8.654) one finds that

$$S_f - S_i = p_1 \beta \log\left(\frac{g_1}{\beta}\right) + p_1 (1 - \beta) \log\left(\frac{1 - g_1}{1 - \beta}\right) \\ + p_2 \beta \log\left(\frac{g_2}{\beta}\right) + p_2 (1 - \beta) \log\left(\frac{1 - g_2}{1 - \beta}\right) , \quad (8.668)$$

where

$$\beta = \langle B \rangle = p_1 g_1 + p_2 g_2 = \frac{g_1 + g_2}{2} \left(1 + \frac{(p_1 - p_2)(g_1 - g_2)}{g_1 + g_2}\right) , \quad (8.669)$$

or (recall that $p_1 + p_2 = 1$)

$$\begin{aligned}
 S_f - S_i &= \frac{1}{2} \log \left(\left(\frac{g_1 g_2}{\beta^2} \right)^\beta \left(\frac{(1-g_1)(1-g_2)}{(1-\beta)^2} \right)^{(1-\beta)} \right) \\
 &\quad + \frac{p_1 - p_2}{2} \log \left(\left(\frac{g_1}{g_2} \right)^\beta \left(\frac{1-g_1}{1-g_2} \right)^{(1-\beta)} \right) .
 \end{aligned} \tag{8.670}$$

For the case where $p_1 = p_2$ this becomes

$$S_f - S_i = \frac{1}{2} \log \left(\left(1 - \left(\frac{g_1 - g_2}{g_1 + g_2} \right)^2 \right)^{\frac{g_1 + g_2}{2}} \left(1 - \left(\frac{g_1 - g_2}{2 - g_1 - g_2} \right)^2 \right)^{\frac{2 - g_1 - g_2}{2}} \right) . \tag{8.671}$$

As is expected, the gained information vanishes when $g_1 = g_2$.

50. The measurement of the observable A_1 is describe by the its extension, which is given by $A_1 1_2$, where 1_2 is the identity operator on subsystem '2'. Thus with the help of Eq. (8.10) one finds that

$$\begin{aligned}
 \langle A_1 \rangle &= \text{Tr}(\rho A_1 1_2) \\
 &= \sum_{n_1, n_2} \langle n_1, n_2 | \rho A_1 1_2 | n_1, n_2 \rangle \\
 &= \sum_{n_1} \langle n_1 | \left(\sum_{n_2} \langle n_2 | \rho | n_2 \rangle_2 \right) A_1 | n_1 \rangle_1 \\
 &= \text{Tr}_1(\rho_1 A_1) .
 \end{aligned} \tag{8.672}$$

51. Consider the unitary transformations (the letter k is used to label the states of the original basis, whereas the transformed states are labeled by the letter l)

$$\mathcal{K}_1^T = u_1 \mathcal{L}_1^T = u_1 (|l_1\rangle_1, |l_2\rangle_1, \dots, |l_{N_1}\rangle_1)^T , \tag{8.673}$$

$$\mathcal{K}_2^T = u_2 \mathcal{L}_2^T = u_2 (|l_1\rangle_2, |l_2\rangle_2, \dots, |l_{N_2}\rangle_2)^T , \tag{8.674}$$

where u_1 (u_2) is a $N_1 \times N_1$ ($N_2 \times N_2$) unitary matrix (i.e. $u_1^\dagger u_1 = 1$ and $u_2^\dagger u_2 = 1$). The state vector $|\psi\rangle$ in the transformed basis is expressed as

$$\begin{aligned}
 |\psi\rangle &= \mathcal{L}_1 \hat{C} \otimes \mathcal{L}_2^T \\
 &= \sum_{l_1, l_2} \hat{C}_{l_1, l_2} |l_1\rangle_1 \otimes |l_2\rangle_2 ,
 \end{aligned} \tag{8.675}$$

where the transformed matrix \hat{C} is given by

$$\hat{C} = u_1^T C u_2 , \tag{8.676}$$

and the corresponding density operator $\rho = |\psi\rangle\langle\psi|$ is expressed as

$$\rho = \sum_{l'_1, l'_2, l''_1, l''_2} \hat{C}_{l'_1, l'_2} \left(\hat{C}_{l''_1, l''_2} \right)^* |l'_1, l'_2\rangle \langle l''_1, l''_2|. \quad (8.677)$$

The following holds

$$\text{Tr } \rho = \sum_{l_1, l_2} \left| \hat{C}_{l_1, l_2} \right|^2 = \text{Tr } S_1 = \text{Tr } S_2 = \text{Tr } (CC^\dagger) = \text{Tr } (C^\dagger C), \quad (8.678)$$

where the $N_1 \times N_1$ ($N_2 \times N_2$) matrix S_1 (S_2) is given by (recall that $u_1^\dagger u_1 = 1$ and $u_2^\dagger u_2 = 1$)

$$S_1 = \hat{C}\hat{C}^\dagger = u_1^\text{T} C u_2 u_2^\dagger C^\dagger u_1^\text{T} = u_1^\text{T} C C^\dagger u_1^\text{T}, \quad (8.679)$$

$$S_2 = \hat{C}^\dagger \hat{C} = u_2^\dagger C^\dagger u_1^\text{T} u_1^\text{T} C u_2 = u_2^\dagger C^\dagger C u_2, \quad (8.680)$$

hence $\text{Tr } \rho = 1$ provided that $|\psi\rangle$ is normalized. The matrix S_1 (S_2) is Hermitian and positive definite, hence the unitary matrix u_1 (u_2) can be chosen to diagonalize S_1 (S_2), and the eigenvalues, which are denoted by q_l , are non-negative. For this transformation, which is called the Schmidt decomposition, the transformed matrix \hat{C} has a diagonal form

$$\hat{C}_{l_1, l_2} = q_{l_1} \delta_{l_1, l_2}. \quad (8.681)$$

For example, for the case $N_1 = 2$ and $N_2 = 3$ the state $|\psi\rangle$ is written as [see Eqs. (8.118) and (8.675)]

$$\begin{aligned} |\psi\rangle &= \begin{bmatrix} |k_1\rangle_1 \\ |k_{N_1}\rangle_1 \end{bmatrix}^\text{T} \begin{bmatrix} C_{11} & C_{12} & C_{13} \\ C_{21} & C_{22} & C_{23} \end{bmatrix} \otimes \begin{bmatrix} |k_1\rangle_2 \\ |k_2\rangle_2 \\ |k_{N_2}\rangle_2 \end{bmatrix} \\ &= \begin{bmatrix} |l_1\rangle_1 \\ |l_{N_1}\rangle_1 \end{bmatrix}^\text{T} u_1^\text{T} \begin{bmatrix} C_{11} & C_{12} & C_{13} \\ C_{21} & C_{22} & C_{23} \end{bmatrix} u_2 \otimes \begin{bmatrix} |l_1\rangle_2 \\ |l_2\rangle_2 \\ |l_{N_2}\rangle_2 \end{bmatrix}, \end{aligned} \quad (8.682)$$

and the density operator ρ as [see Eq. (8.677)]

$$\begin{aligned} \rho &= \begin{bmatrix} |l_1\rangle_1 \\ |l_{N_1}\rangle_1 \end{bmatrix}^\text{T} u_1^\text{T} \begin{bmatrix} C_{11} & C_{12} & C_{13} \\ C_{21} & C_{22} & C_{23} \end{bmatrix} u_2 \\ &\otimes \begin{bmatrix} |l_1\rangle_2 \ 2 \langle l_1| & |l_1\rangle_2 \ 2 \langle l_2| & |l_1\rangle_2 \ 2 \langle l_{N_2}| \\ |l_2\rangle_2 \ 2 \langle l_1| & |l_2\rangle_2 \ 2 \langle l_2| & |l_2\rangle_2 \ 2 \langle l_{N_2}| \\ |l_{N_2}\rangle_2 \ 2 \langle l_1| & |l_{N_2}\rangle_2 \ 2 \langle l_2| & |l_{N_2}\rangle_2 \ 2 \langle l_{N_2}| \end{bmatrix} \\ &\otimes u_2^\dagger \begin{bmatrix} C_{11} & C_{12} & C_{13} \\ C_{21} & C_{22} & C_{23} \end{bmatrix}^\dagger u_1^\text{T} \begin{bmatrix} 1 \langle l_1| \\ 1 \langle l_{N_1}| \end{bmatrix}. \end{aligned}$$

For this example the following holds [see Eq. (8.678)]

$$\begin{aligned}
 & \begin{bmatrix} C_{11} & C_{12} & C_{13} \\ C_{21} & C_{22} & C_{23} \end{bmatrix}^\dagger \begin{bmatrix} C_{11} & C_{12} & C_{13} \\ C_{21} & C_{22} & C_{23} \end{bmatrix} \\
 &= \begin{bmatrix} |C_{11}|^2 + |C_{21}|^2 & C_{11}^* C_{12} + C_{21}^* C_{22} & C_{11}^* C_{13} + C_{21}^* C_{23} \\ C_{11} C_{12}^* + C_{21} C_{22}^* & |C_{12}|^2 + |C_{22}|^2 & C_{12}^* C_{13} + C_{22}^* C_{23} \\ C_{11} C_{13}^* + C_{21} C_{23}^* & C_{12} C_{13}^* + C_{22} C_{23}^* & |C_{13}|^2 + |C_{23}|^2 \end{bmatrix}, \tag{8.683}
 \end{aligned}$$

and

$$\begin{aligned}
 & \begin{bmatrix} C_{11} & C_{12} & C_{13} \\ C_{21} & C_{22} & C_{23} \end{bmatrix} \begin{bmatrix} C_{11} & C_{12} & C_{13} \\ C_{21} & C_{22} & C_{23} \end{bmatrix}^\dagger \\
 &= \begin{bmatrix} |C_{11}|^2 + |C_{12}|^2 + |C_{13}|^2 & C_{11} C_{21}^* + C_{12} C_{22}^* + C_{13} C_{23}^* \\ C_{11}^* C_{21} + C_{12}^* C_{22} + C_{13}^* C_{23} & |C_{21}|^2 + |C_{22}|^2 + |C_{23}|^2 \end{bmatrix}, \tag{8.684}
 \end{aligned}$$

and the Schmidt decomposition yields [see Eq. (8.681)]

$$\begin{bmatrix} \hat{C}_{11} & \hat{C}_{12} & \hat{C}_{13} \\ \hat{C}_{21} & \hat{C}_{22} & \hat{C}_{23} \end{bmatrix} = \begin{bmatrix} q_1 & 0 & 0 \\ 0 & q_2 & 0 \end{bmatrix},$$

hence (recall that q_l , are non-negative real numbers)

$$S_1 = \hat{C} \hat{C}^\dagger = \begin{bmatrix} q_1 & 0 & 0 \\ 0 & q_2 & 0 \end{bmatrix} \begin{bmatrix} q_1 & 0 & 0 \\ 0 & q_2 & 0 \end{bmatrix}^\dagger = \begin{bmatrix} q_1^2 & 0 \\ 0 & q_2^2 \end{bmatrix}, \tag{8.685}$$

and

$$S_2 = \hat{C}^\dagger \hat{C} = \begin{bmatrix} q_1 & 0 & 0 \\ 0 & q_2 & 0 \end{bmatrix}^\dagger \begin{bmatrix} q_1 & 0 & 0 \\ 0 & q_2 & 0 \end{bmatrix} = \begin{bmatrix} q_1^2 & 0 & 0 \\ 0 & q_2^2 & 0 \\ 0 & 0 & 0 \end{bmatrix}, \tag{8.686}$$

where $q_1^2 + q_2^2 = 1$.

- a) With the help of the Schmidt decomposition (8.681), one finds that $P_1 = P_2 \equiv P$, where

$$P = \sum_l q_l^4 = \text{Tr } S_1^2 = \text{Tr} \left((C C^\dagger)^2 \right) = \text{Tr } S_2^2 = \text{Tr} \left((C^\dagger C)^2 \right). \tag{8.687}$$

Note that $P = 1$ for a product state, and P obtains its minimum value of $1/\min(N_1, N_2)$ for a maximally entangled state. The purity P is independent on the local transformations u_1 and u_2 , hence it is a constant when the subsystems are decoupled (i.e. when the interaction between the subsystems vanishes). Using the relations

$$\text{Tr} (C^\dagger C) = \sum_{k'_2=1}^{N_2} (C^\dagger C)_{k'_2, k'_2} = \sum_{k'_1=1}^{N_1} \sum_{k'_2=1}^{N_2} C_{k'_1, k'_2}^* C_{k'_1, k'_2}, \tag{8.688}$$

and

$$\begin{aligned}
\text{Tr} (C^\dagger C)^2 &= \sum_{k'_2=1}^{N_2} \left((C^\dagger C)^2 \right)_{k'_2, k'_2} \\
&= \sum_{k'_2, k''_2=1}^{N_2} (C^\dagger C)_{k'_2, k''_2} (C^\dagger C)_{k''_2, k'_2} \\
&= \sum_{k'_1, k''_1=1}^{N_1} \sum_{k'_2, k''_2=1}^{N_2} C_{k'_1, k'_2}^* C_{k'_1, k''_2} C_{k''_1, k''_2}^* C_{k''_1, k'_2} ,
\end{aligned} \tag{8.689}$$

one finds that the level of entanglement $Q = 1 - P$ is given by

$$\begin{aligned}
Q &= (\text{Tr} (C^\dagger C))^2 - \text{Tr} (C^\dagger C)^2 \\
&= \sum_{k'_1, k''_1=1}^{N_1} \sum_{k'_2, k''_2=1}^{N_2} \left(C_{k'_1, k'_2}^* C_{k'_1, k''_2} C_{k''_1, k''_2}^* C_{k''_1, k'_2} - C_{k'_1, k'_2}^* C_{k'_1, k''_2} C_{k''_1, k''_2}^* C_{k''_1, k'_2} \right) \\
&= \frac{1}{2} \sum_{k'_1, k''_1=1}^{N_1} \sum_{k'_2, k''_2=1}^{N_2} \left| \phi_{k'_1, k''_1, k'_2, k''_2} \right|^2 ,
\end{aligned} \tag{8.690}$$

where

$$\phi_{k'_1, k''_1, k'_2, k''_2} = C_{k'_1, k'_2} C_{k''_1, k''_2} - C_{k'_1, k''_2} C_{k''_1, k'_2} . \tag{8.691}$$

Note that the term $\phi_{k'_1, k''_1, k'_2, k''_2}$ vanishes unless $k'_1 \neq k''_1$ and $k'_2 \neq k''_2$, and the following holds $\phi_{k'_1, k''_1, k'_2, k''_2} = \phi_{k''_1, k'_1, k''_2, k'_2}$, thus Eq. (8.690) can be rewritten as

$$Q = 2 \sum_{k'_1 < k''_1} \sum_{k'_2 < k''_2} \left| \phi_{k'_1, k''_1, k'_2, k''_2} \right|^2 . \tag{8.692}$$

The above result (8.692) leads to Eq. (8.121). Note that for any product state $\phi_{k'_1, k''_1, k'_2, k''_2} = 0$ [see Eq. (8.691)]. For example, for the case $N_1 = 2$ and $N_2 = 3$, and for a product state $|\psi\rangle$ having the form

$$|\psi\rangle = (\alpha_1 |k_1\rangle_1 + \alpha_2 |k_2\rangle_1) \otimes (\beta_1 |k_1\rangle_2 + \beta_2 |k_2\rangle_2 + \beta_3 |k_3\rangle_2) , \tag{8.693}$$

the following holds [see Eq. (8.118)]

$$\begin{aligned}
|\psi\rangle &= \begin{bmatrix} |k_1\rangle_1 \\ |k_{N_1}\rangle_1 \end{bmatrix}^T \begin{bmatrix} \alpha_1 \\ \alpha_2 \end{bmatrix} \begin{bmatrix} \beta_1 & \beta_2 & \beta_3 \end{bmatrix} \otimes \begin{bmatrix} |k_1\rangle_2 \\ |k_2\rangle_2 \\ |k_{N_2}\rangle_2 \end{bmatrix} \\
&= \begin{bmatrix} |k_1\rangle_1 \\ |k_{N_1}\rangle_1 \end{bmatrix}^T \begin{bmatrix} \alpha_1 \beta_1 & \alpha_1 \beta_2 & \alpha_1 \beta_3 \\ \alpha_2 \beta_1 & \alpha_2 \beta_2 & \alpha_2 \beta_3 \end{bmatrix} \otimes \begin{bmatrix} |k_1\rangle_2 \\ |k_2\rangle_2 \\ |k_{N_2}\rangle_2 \end{bmatrix} ,
\end{aligned} \tag{8.694}$$

and thus $C_{k_1, k_2} = \alpha_{k_1} \beta_{k_2}$.

b) With the help of Eq. (8.677) one finds that [see Eq. (8.117)]

$$\rho_1 = \text{Tr}_2 \rho = \sum_{l'_1, l''_1, l''_2} \hat{C}_{l'_1, l''_2} \left(\hat{C}_{l''_1, l''_2} \right)^* {}_1 \langle l'_1 | \langle l''_1 | {}_1 \rangle, \quad (8.695)$$

$$\rho_2 = \text{Tr}_1 \rho = \sum_{l'_2, l''_2, l''_1} \hat{C}_{l''_1, l'_2} \left(\hat{C}_{l''_1, l''_2} \right)^* {}_2 \langle l'_2 | \langle l''_2 | {}_2 \rangle, \quad (8.696)$$

hence for the case of the Schmidt decomposition [see Eq. (8.681)]

$$\begin{aligned} \rho_1 &= \sum_{l'_1, l''_1, l''_2} q_{l'_1} q_{l''_1} \delta_{l'_1, l''_2} \delta_{l''_1, l''_2} {}_1 \langle l'_1 | \langle l''_1 | {}_1 \rangle \\ &= \sum_{l'_1} q_{l'_1}^2 {}_1 \langle l'_1 | \langle l'_1 | {}_1 \rangle, \end{aligned} \quad (8.697)$$

$$\begin{aligned} \rho_2 &= \sum_{l'_2, l''_2, l''_1} q_{l'_2} q_{l''_2} \delta_{l'_2, l''_1} \delta_{l''_2, l''_1} {}_2 \langle l'_2 | \langle l''_2 | {}_2 \rangle \\ &= \sum_{l'_2} q_{l'_2}^2 {}_2 \langle l'_2 | \langle l'_2 | {}_2 \rangle. \end{aligned} \quad (8.698)$$

Using Eqs. (8.697), (8.698) and (8.103) one finds that

$$\sigma_1 = \sigma_2 = - \sum_l q_l^2 \log q_l^2. \quad (8.699)$$

c) By evaluating the partial traces of $|\psi\rangle\langle\psi|$ one finds that [see Eq. (8.117), and note the normalization condition $|a|^2 + |b|^2 + |c|^2 + |d|^2 = 1$]

$$\begin{aligned} \rho_1 &= (a|-) + c|+) (a^* \langle -| + c^* \langle +|) + (b|-) + d|+) (b^* \langle -| + d^* \langle +|) \\ &\doteq \begin{pmatrix} |a|^2 + |b|^2 & ac^* + bd^* \\ ca^* + db^* & |c|^2 + |d|^2 \end{pmatrix} \\ &= \begin{pmatrix} \frac{1}{2} + \frac{|a|^2 + |b|^2 - |c|^2 - |d|^2}{2} & ac^* + bd^* \\ ca^* + db^* & \frac{1}{2} - \frac{|a|^2 + |b|^2 - |c|^2 - |d|^2}{2} \end{pmatrix}, \end{aligned} \quad (8.700)$$

and

$$\begin{aligned} \rho_2 &= (a|-) + b|+) (a^* \langle -| + b^* \langle +|) + (c|-) + d|+) (c^* \langle -| + d^* \langle +|) \\ &\doteq \begin{pmatrix} |a|^2 + |c|^2 & ab^* + cd^* \\ ba^* + dc^* & |b|^2 + |d|^2 \end{pmatrix} \\ &= \begin{pmatrix} \frac{1}{2} + \frac{|a|^2 + |c|^2 - |b|^2 - |d|^2}{2} & ab^* + cd^* \\ ba^* + dc^* & \frac{1}{2} - \frac{|a|^2 + |c|^2 - |b|^2 - |d|^2}{2} \end{pmatrix}, \end{aligned} \quad (8.701)$$

and thus both ρ_1 and ρ_2 have trace equals 1 and determinant D given by [note the identities $|ad - bc|^2 + |ac^* + bd^*|^2 = (|a|^2 + |b|^2)(|c|^2 + |d|^2)$ and $|ad - bc|^2 + |ab^* + cd^*|^2 = (|a|^2 + |c|^2)(|b|^2 + |d|^2)$, and recall the normalization condition]

$$\begin{aligned} D &= \frac{1}{4} - \frac{(|a|^2 + |b|^2 - |c|^2 - |d|^2)^2}{4} - |ac^* + bd^*|^2 \\ &= \frac{1}{4} - \frac{(|a|^2 + |c|^2 - |b|^2 - |d|^2)^2}{4} - |ab^* + cd^*|^2 \\ &= |ad - bc|^2, \end{aligned}$$

hence the eigenvalues ρ_{\pm} of both ρ_1 and ρ_2 are given by

$$\rho_{\pm} = \frac{1 \pm \sqrt{1 - 4D}}{2}. \quad (8.702)$$

Thus for this case $P_1 = P_2 \equiv P$, and the following holds

$$Q = 1 - P = 1 - \rho_-^2 - \rho_+^2 = 2D. \quad (8.703)$$

To show that the above result (8.703) is consistent with Eq. (8.121), note that for the two spin system, for which $N_1 = N_2 = 2$, Eq. (8.121) yields [the sum in Eq. (8.121) contains a single term with $k'_1 = -$, $k''_1 = +$, $k'_2 = -$ and $k''_2 = +$]

$$Q = 2 |\langle \Psi | \psi \rangle|^2, \quad (8.704)$$

where [see Eq. (8.122)]

$$\langle \Psi | = d \langle -- | - c \langle -+ |. \quad (8.705)$$

hence

$$Q = 2 |ad - bc|^2, \quad (8.706)$$

in agreement with Eq. (8.703). The entropies σ_1 and σ_2 are given by [see Eq. (8.702)]

$$\sigma_1 = \sigma_2 = -\rho_+ \log \rho_+ - \rho_- \log \rho_-. \quad (8.707)$$

The following holds

$$ad - bc = \frac{\langle \psi_{\text{F}} | \psi \rangle}{2}, \quad (8.708)$$

where the state $\langle \psi_{\text{F}} |$, which is normalized (provided that $|\psi\rangle$ is normalized), is given by

$$\langle \psi_{\mathbf{F}} | = d \langle -- | - c \langle -+ | - b \langle +- | + a \langle ++ | , \quad (8.709)$$

hence [see Eq. (8.706)]

$$0 \leq Q \leq \frac{1}{2} . \quad (8.710)$$

d) For the Bell's states $\rho_1^{(A\pm)} \doteq M$, $\rho_2^{(A\pm)} \doteq M$, $\rho_1^{(P\pm)} \doteq M$ and $\rho_2^{(P\pm)} \doteq M$, where the matrix M is given by

$$M = \begin{pmatrix} \frac{1}{2} & 0 \\ 0 & \frac{1}{2} \end{pmatrix} , \quad (8.711)$$

and thus $\sigma_1 = \sigma_2 = \log 2$ for all four Bell states.

52. The following holds [see Eq. (8.10)]

$$\frac{2 \langle S_{nx} \rangle}{\hbar} = \text{Tr} (\rho_n \sigma_x) , \quad (8.712)$$

$$\frac{2 \langle S_{ny} \rangle}{\hbar} = \text{Tr} (\rho_n \sigma_y) , \quad (8.713)$$

$$\frac{2 \langle S_{nz} \rangle}{\hbar} = \text{Tr} (\rho_n \sigma_z) , \quad (8.714)$$

where $n \in \{1, 2\}$, the reduced density matrices ρ_1 and ρ_2 are given by Eqs. (8.700) and (8.701), respectively, and where σ_x , σ_y and σ_z are Pauli matrices [see Eq. (6.137)], thus

$$\frac{2 \langle S_{1x} \rangle}{\hbar} = c^* a + a^* c + d^* b + b^* d , \quad (8.715)$$

$$\frac{2 \langle S_{1y} \rangle}{\hbar} = i (c^* a - a^* c + d^* b - b^* d) , \quad (8.716)$$

$$\frac{2 \langle S_{1z} \rangle}{\hbar} = |a|^2 + |b|^2 - |c|^2 - |d|^2 , \quad (8.717)$$

and

$$\frac{2 \langle S_{2x} \rangle}{\hbar} = b^* a + a^* b + d^* c + c^* d , \quad (8.718)$$

$$\frac{2 \langle S_{2y} \rangle}{\hbar} = i (b^* a - a^* b + d^* c - c^* d) , \quad (8.719)$$

$$\frac{2 \langle S_{2z} \rangle}{\hbar} = |a|^2 + |c|^2 - |b|^2 - |d|^2 , \quad (8.720)$$

hence

$$\begin{aligned} (2/\hbar)^2 |\langle \mathbf{S}_1 \rangle|^2 &= (c^* a + a^* c + d^* b + b^* d)^2 + (i (c^* a - a^* c + d^* b - b^* d))^2 \\ &\quad + (a^* a + b^* b - c^* c - d^* d)^2 \\ &= \left(|a|^2 + |b|^2 + |c|^2 + |d|^2 \right)^2 - 4 |ad - bc|^2 , \end{aligned} \quad (8.721)$$

and

$$\begin{aligned} (2/\hbar)^2 |\langle \mathbf{S}_2 \rangle|^2 &= (b^*a + a^*b + d^*c + c^*d)^2 + (i(b^*a - a^*b + d^*c - c^*d))^2 \\ &\quad + (a^*a - b^*b + c^*c - d^*d)^2 \\ &= \left(|a|^2 + |b|^2 + |c|^2 + |d|^2 \right)^2 - 4|ad - bc|^2, \end{aligned} \quad (8.722)$$

or [recall the normalization condition $|a|^2 + |b|^2 + |c|^2 + |d|^2 = 1$, and compare with Eq. (8.706)]

$$(2/\hbar)^2 |\langle \mathbf{S}_1 \rangle|^2 = (2/\hbar)^2 |\langle \mathbf{S}_2 \rangle|^2 = 1 - 4|ad - bc|^2, \quad (8.723)$$

and $|\langle \mathbf{S}_1 \rangle|^2 - |\langle \mathbf{S}_2 \rangle|^2 = 0$.

53. Time evolution of a single spin can be represented by a 2×2 matrix unitary matrix given by [see Eqs. (6.301) and (6.302)]

$$u(\theta, \varphi) \doteq \begin{pmatrix} \cos \frac{\theta}{2} e^{-\frac{i\varphi}{2}} & -\sin \frac{\theta}{2} e^{-\frac{i\varphi}{2}} \\ \sin \frac{\theta}{2} e^{\frac{i\varphi}{2}} & \cos \frac{\theta}{2} e^{\frac{i\varphi}{2}} \end{pmatrix}, \quad (8.724)$$

where both θ and φ are real. When the two spins are decoupled the time evolution of the pair can be expressed as $U = u_1(\theta_1, \varphi_1) \otimes u_2(\theta_2, \varphi_2)$, where u_1 (u_2) acts on the first (second) spin, θ_n and φ_n are real, and \otimes represents a tensor product, i.e. the matrix representation of the unitary operator U is given by (in a block form)

$$U \doteq \left(\begin{array}{c|c} \cos \frac{\theta_1}{2} e^{-\frac{i\varphi_1}{2}} \begin{pmatrix} \cos \frac{\theta_2}{2} e^{-\frac{i\varphi_2}{2}} & -\sin \frac{\theta_2}{2} e^{-\frac{i\varphi_2}{2}} \\ \sin \frac{\theta_2}{2} e^{\frac{i\varphi_2}{2}} & \cos \frac{\theta_2}{2} e^{\frac{i\varphi_2}{2}} \end{pmatrix} & -\sin \frac{\theta_1}{2} e^{-\frac{i\varphi_1}{2}} \begin{pmatrix} \cos \frac{\theta_2}{2} e^{-\frac{i\varphi_2}{2}} & -\sin \frac{\theta_2}{2} e^{-\frac{i\varphi_2}{2}} \\ \sin \frac{\theta_2}{2} e^{\frac{i\varphi_2}{2}} & \cos \frac{\theta_2}{2} e^{\frac{i\varphi_2}{2}} \end{pmatrix} \\ \hline \sin \frac{\theta_1}{2} e^{\frac{i\varphi_1}{2}} \begin{pmatrix} \cos \frac{\theta_2}{2} e^{-\frac{i\varphi_2}{2}} & -\sin \frac{\theta_2}{2} e^{-\frac{i\varphi_2}{2}} \\ \sin \frac{\theta_2}{2} e^{\frac{i\varphi_2}{2}} & \cos \frac{\theta_2}{2} e^{\frac{i\varphi_2}{2}} \end{pmatrix} & \cos \frac{\theta_1}{2} e^{\frac{i\varphi_1}{2}} \begin{pmatrix} \cos \frac{\theta_2}{2} e^{-\frac{i\varphi_2}{2}} & -\sin \frac{\theta_2}{2} e^{-\frac{i\varphi_2}{2}} \\ \sin \frac{\theta_2}{2} e^{\frac{i\varphi_2}{2}} & \cos \frac{\theta_2}{2} e^{\frac{i\varphi_2}{2}} \end{pmatrix} \end{array} \right), \quad (8.725)$$

or (as a 4×4 matrix)

$$U \doteq \begin{pmatrix} \cos \frac{\theta_1}{2} e^{-\frac{i\varphi_1}{2}} \cos \frac{\theta_2}{2} e^{-\frac{i\varphi_2}{2}} & -\cos \frac{\theta_1}{2} e^{-\frac{i\varphi_1}{2}} \sin \frac{\theta_2}{2} e^{-\frac{i\varphi_2}{2}} & -\sin \frac{\theta_1}{2} e^{-\frac{i\varphi_1}{2}} \cos \frac{\theta_2}{2} e^{-\frac{i\varphi_2}{2}} & \sin \frac{\theta_1}{2} e^{-\frac{i\varphi_1}{2}} \sin \frac{\theta_2}{2} e^{-\frac{i\varphi_2}{2}} \\ \cos \frac{\theta_1}{2} e^{-\frac{i\varphi_1}{2}} \sin \frac{\theta_2}{2} e^{\frac{i\varphi_2}{2}} & \cos \frac{\theta_1}{2} e^{-\frac{i\varphi_1}{2}} \cos \frac{\theta_2}{2} e^{\frac{i\varphi_2}{2}} & -\sin \frac{\theta_1}{2} e^{-\frac{i\varphi_1}{2}} \left(\sin \frac{\theta_2}{2} \right) e^{\frac{i\varphi_2}{2}} & -\sin \frac{\theta_1}{2} e^{-\frac{i\varphi_1}{2}} \cos \frac{\theta_2}{2} e^{\frac{i\varphi_2}{2}} \\ \sin \frac{\theta_1}{2} e^{\frac{i\varphi_1}{2}} \cos \frac{\theta_2}{2} e^{-\frac{i\varphi_2}{2}} & -\sin \frac{\theta_1}{2} e^{\frac{i\varphi_1}{2}} \sin \frac{\theta_2}{2} e^{-\frac{i\varphi_2}{2}} & \cos \frac{\theta_1}{2} e^{\frac{i\varphi_1}{2}} \cos \frac{\theta_2}{2} e^{-\frac{i\varphi_2}{2}} & -\cos \frac{\theta_1}{2} e^{\frac{i\varphi_1}{2}} \sin \frac{\theta_2}{2} e^{-\frac{i\varphi_2}{2}} \\ \sin \frac{\theta_1}{2} e^{\frac{i\varphi_1}{2}} \sin \frac{\theta_2}{2} e^{\frac{i\varphi_2}{2}} & \sin \frac{\theta_1}{2} e^{\frac{i\varphi_1}{2}} \cos \frac{\theta_2}{2} e^{\frac{i\varphi_2}{2}} & \cos \frac{\theta_1}{2} e^{\frac{i\varphi_1}{2}} \sin \frac{\theta_2}{2} e^{\frac{i\varphi_2}{2}} & \cos \frac{\theta_1}{2} e^{\frac{i\varphi_1}{2}} \cos \frac{\theta_2}{2} e^{\frac{i\varphi_2}{2}} \end{pmatrix}, \quad (8.726)$$

and the following holds

$$\begin{pmatrix} a(t) \\ b(t) \\ c(t) \\ d(t) \end{pmatrix} = U \begin{pmatrix} a(0) \\ b(0) \\ c(0) \\ d(0) \end{pmatrix}. \quad (8.727)$$

a) The above relation (8.727) can be rewritten as [see Eq. (8.726)]

$$K(t) = u_1(\theta_1, \varphi_1) K(0) u_2^T(\theta_2, \varphi_2), \quad (8.728)$$

where T represents matrix transpose, and where the 2×2 matrix $K(t)$ is defined by

$$K(t) = \begin{pmatrix} a(t) & b(t) \\ c(t) & d(t) \end{pmatrix}. \quad (8.729)$$

The following holds $\det(K(t)) = \det(u_1(\theta_1, \varphi_1)) \det(K(0)) \det(u_2^T(\theta_2, \varphi_2))$, $\det(u(\theta, \varphi)) = \det(u^T(\theta, \varphi)) = 1$, and $\det K = \kappa$, hence $\kappa(t) = a(t)d(t) - b(t)c(t)$ is time independent.

b) The following holds

$$\begin{pmatrix} |A_-\rangle \\ |A_+\rangle \\ |P_-\rangle \\ |P_+\rangle \end{pmatrix} = U_B \begin{pmatrix} |--\rangle \\ |-\rangle \\ |+\rangle \\ |++\rangle \end{pmatrix}. \quad (8.730)$$

where the matrix U_B is given by [see Eqs. (8.124) and (8.125)]

$$U_B = \begin{pmatrix} 0 & -\frac{1}{\sqrt{2}} & \frac{1}{\sqrt{2}} & 0 \\ 0 & \frac{1}{\sqrt{2}} & \frac{1}{\sqrt{2}} & 0 \\ -\frac{1}{\sqrt{2}} & 0 & 0 & \frac{1}{\sqrt{2}} \\ \frac{1}{\sqrt{2}} & 0 & 0 & \frac{1}{\sqrt{2}} \end{pmatrix}. \quad (8.731)$$

hence

$$(\alpha \ \beta \ \gamma \ \delta) U_B = (a \ b \ c \ d). \quad (8.732)$$

Using the above relation (8.732) one finds that the matrix K can be expressed as [see Eq. (8.729)]

$$K = \begin{pmatrix} \frac{\delta-\gamma}{\sqrt{2}} & \frac{\beta-\alpha}{\sqrt{2}} \\ \frac{\beta+\alpha}{\sqrt{2}} & \frac{\delta+\gamma}{\sqrt{2}} \end{pmatrix}, \quad (8.733)$$

hence

$$\kappa = \det K = \frac{\alpha^2 - \beta^2 - \gamma^2 + \delta^2}{2} = \frac{\eta}{2}, \quad (8.734)$$

and thus $\eta(t)$ is time independent. Note that for the case where $\theta_1 = \theta_2 = \theta$ and $\varphi_1 = \varphi_2 = \varphi$ one has [see Eq. (8.728)]

$$\begin{pmatrix} a(t) & b(t) \\ c(t) & d(t) \end{pmatrix} = u_1(\theta, \varphi) \begin{pmatrix} a(0) & b(0) \\ c(0) & d(0) \end{pmatrix} u_2^T(\theta, \varphi), \quad (8.735)$$

where

$$a(t) = -\frac{(b(0) + c(0)) \sin \theta - 2a(0) \cos^2 \frac{\theta}{2} - 2d(0) \sin^2 \frac{\theta}{2}}{2} e^{-i\varphi}, \quad (8.736)$$

$$b(t) = \frac{(a(0) - d(0)) \sin \theta - (b(0) + c(0)) (1 - \cos \theta) + 2b(0)}{2}, \quad (8.737)$$

$$c(t) = \frac{(a(0) - d(0)) \sin \theta - (b(0) + c(0)) (1 - \cos \theta) + 2c(0)}{2}, \quad (8.738)$$

$$d(t) = \frac{(b(0) + c(0)) \sin \theta + 2a(0) \sin^2 \frac{\theta}{2} + 2d(0) \cos^2 \frac{\theta}{2}}{2} e^{i\varphi}, \quad (8.739)$$

hence for this case

$$\alpha(t) = -\frac{b(t) - c(t)}{\sqrt{2}} = -\frac{b(0) - c(0)}{\sqrt{2}} = \alpha(0), \quad (8.740)$$

is time independent [compare with Eq. (6.694)]. Note also that for this case one has

$$a(t) e^{i\varphi} + d(t) e^{-i\varphi} = a(0) + d(0). \quad (8.741)$$

54. The normalization condition $\langle \psi | \psi \rangle = 1$ yields

$$|a|^2 + |b|^2 + 2 \operatorname{Re}(\varkappa \zeta \langle bs | as \rangle) = 1, \quad (8.742)$$

where

$$\varkappa = ab^*, \quad (8.743)$$

$$\zeta = \langle bo | ao \rangle. \quad (8.744)$$

The reduced density matrix of the two-level subsystem ρ_s is given by

$$\rho_s = \begin{pmatrix} |aa_1|^2 + |bb_1|^2 + 2 \operatorname{Re}(\varkappa \zeta a_1 b_1^*) & \eta \\ \eta^* & |aa_2|^2 + |bb_2|^2 + 2 \operatorname{Re}(\varkappa \zeta a_2 b_2^*) \end{pmatrix}, \quad (8.745)$$

where

$$\eta = |a|^2 a_1 a_2^* + |b|^2 b_1 b_2^* + \varkappa \zeta a_1 b_2^* + \varkappa^* \zeta^* a_2^* b_1, \quad (8.746)$$

or by [see Eq. (8.742)]

$$\rho_s = \begin{pmatrix} \frac{1}{2} + \kappa & \eta \\ \eta^* & \frac{1}{2} - \kappa \end{pmatrix}, \quad (8.747)$$

where

$$\kappa = \frac{|a|^2 (|a_1|^2 - |a_2|^2) + |b|^2 (|b_1|^2 - |b_2|^2)}{2} + \text{Re}(\varkappa\zeta (a_1 b_1^* - a_2 b_2^*)) , \quad (8.748)$$

hence

$$\rho_s = \frac{1 + \mathbf{k} \cdot \boldsymbol{\sigma}}{2} , \quad (8.749)$$

where

$$\mathbf{k} = 2(\eta', -\eta'', \kappa) , \quad (8.750)$$

with $\eta' = \text{Re} \eta$ and $\eta'' = \text{Im} \eta$, and $\boldsymbol{\sigma} = (\sigma_x, \sigma_y, \sigma_z)$ is the Pauli matrix vector [see Eq. (6.137)]. Note that

$$\text{Tr} \rho_s^2 = \frac{1 + |\mathbf{k}|^2}{2} . \quad (8.751)$$

The normalized eigenvectors of $\mathbf{k} \cdot \boldsymbol{\sigma}$ are given by [see Eqs. (6.301) and (6.302)]

$$|+\rangle \doteq \begin{pmatrix} \cos \frac{\theta}{2} e^{-\frac{i\varphi}{2}} \\ \sin \frac{\theta}{2} e^{\frac{i\varphi}{2}} \end{pmatrix} , \quad (8.752)$$

$$|-\rangle \doteq \begin{pmatrix} -\sin \frac{\theta}{2} e^{-\frac{i\varphi}{2}} \\ \cos \frac{\theta}{2} e^{\frac{i\varphi}{2}} \end{pmatrix} , \quad (8.753)$$

where in spherical coordinates

$$\hat{\mathbf{k}} \equiv \frac{\mathbf{k}}{|\mathbf{k}|} = (\cos \varphi \sin \theta, \sin \varphi \sin \theta, \cos \theta) . \quad (8.754)$$

By employing the closure relation $1 = |+\rangle \langle +| + |-\rangle \langle -|$ one finds that $|\psi\rangle$ can be expressed as

$$|\psi\rangle = \sqrt{\frac{1 + |\mathbf{k}|}{2}} |+\rangle |O_+\rangle + \sqrt{\frac{1 - |\mathbf{k}|}{2}} |-\rangle |O_-\rangle , \quad (8.755)$$

where the ancilla subsystem states $|O_\pm\rangle$ are given by [see Eq. (8.129)]

$$|O_+\rangle = \frac{a\mathcal{A}_+ |a_0\rangle + b\mathcal{B}_+ |b_0\rangle}{\sqrt{\frac{1 + |\mathbf{k}|}{2}}} , \quad (8.756)$$

$$|O_-\rangle = \frac{a\mathcal{A}_- |a_0\rangle + b\mathcal{B}_- |b_0\rangle}{\sqrt{\frac{1 - |\mathbf{k}|}{2}}} , \quad (8.757)$$

where

$$\mathcal{A}_+ = \langle + | \text{as} \rangle = a_1 \cos \frac{\theta}{2} e^{\frac{i\varphi}{2}} + a_2 \sin \frac{\theta}{2} e^{-\frac{i\varphi}{2}}, \quad (8.758)$$

$$\mathcal{B}_+ = \langle + | \text{bs} \rangle = b_1 \cos \frac{\theta}{2} e^{\frac{i\varphi}{2}} + b_2 \sin \frac{\theta}{2} e^{-\frac{i\varphi}{2}}, \quad (8.759)$$

$$\mathcal{A}_- = \langle - | \text{as} \rangle = -a_1 \sin \frac{\theta}{2} e^{\frac{i\varphi}{2}} + a_2 \cos \frac{\theta}{2} e^{-\frac{i\varphi}{2}}, \quad (8.760)$$

$$\mathcal{B}_- = \langle - | \text{bs} \rangle = -b_1 \sin \frac{\theta}{2} e^{\frac{i\varphi}{2}} + b_2 \cos \frac{\theta}{2} e^{-\frac{i\varphi}{2}}, \quad (8.761)$$

thus

$$|O_+\rangle = \frac{|1o\rangle \cos \frac{\theta}{2} e^{\frac{i\varphi}{2}} + |2o\rangle \sin \frac{\theta}{2} e^{-\frac{i\varphi}{2}}}{\sqrt{\frac{1+|\mathbf{k}|}{2}}}, \quad (8.762)$$

$$|O_-\rangle = \frac{-|1o\rangle \sin \frac{\theta}{2} e^{\frac{i\varphi}{2}} + |2o\rangle \cos \frac{\theta}{2} e^{-\frac{i\varphi}{2}}}{\sqrt{\frac{1-|\mathbf{k}|}{2}}}, \quad (8.763)$$

where

$$|1o\rangle = aa_1 |ao\rangle + bb_1 |bo\rangle, \quad (8.764)$$

$$|2o\rangle = aa_2 |ao\rangle + bb_2 |bo\rangle, \quad (8.765)$$

or [see Eq. (8.754) and recall that $\cos^2(\theta/2) = (1 + \cos \theta)/2$ and $\sin^2(\theta/2) = (1 - \cos \theta)/2$]

$$|O_+\rangle = |1o\rangle \sqrt{\sqrt{\frac{1 + \frac{k_z}{|\mathbf{k}|} \frac{k_x + ik_y}{|\mathbf{k}|}}{1 - \frac{k_z}{|\mathbf{k}|} \frac{k_x + ik_y}{|\mathbf{k}|}}} + |2o\rangle \sqrt{\sqrt{\frac{1 - \frac{k_z}{|\mathbf{k}|} \frac{k_x - ik_y}{|\mathbf{k}|}}{1 + \frac{k_z}{|\mathbf{k}|} \frac{k_x - ik_y}{|\mathbf{k}|}}}, \quad (8.766)$$

$$|O_-\rangle = -|1o\rangle \sqrt{\sqrt{\frac{1 - \frac{k_z}{|\mathbf{k}|} \frac{k_x + ik_y}{|\mathbf{k}|}}{1 + \frac{k_z}{|\mathbf{k}|} \frac{k_x + ik_y}{|\mathbf{k}|}}} + |2o\rangle \sqrt{\sqrt{\frac{1 + \frac{k_z}{|\mathbf{k}|} \frac{k_x - ik_y}{|\mathbf{k}|}}{1 - \frac{k_z}{|\mathbf{k}|} \frac{k_x - ik_y}{|\mathbf{k}|}}}. \quad (8.767)$$

Using the relations

$$\langle 1o | 1o \rangle = |aa_1|^2 + |bb_1|^2 + 2 \operatorname{Re}(\varkappa \zeta a_1 b_1^*), \quad (8.768)$$

$$\langle 2o | 2o \rangle = |aa_2|^2 + |bb_2|^2 + 2 \operatorname{Re}(\varkappa \zeta a_2 b_2^*), \quad (8.769)$$

which imply that [see Eqs. (8.742) and (8.748)]

$$\langle 1o | 1o \rangle + \langle 2o | 2o \rangle = 1, \quad (8.770)$$

$$\langle 1o | 1o \rangle - \langle 2o | 2o \rangle = 2\kappa, \quad (8.771)$$

and the relation [see Eq. (8.746)]

$$\langle 2o | 1o \rangle = |a|^2 a_1 a_2^* + |b|^2 b_1 b_2^* + \varkappa \zeta a_1 b_2^* + \varkappa^* \zeta^* a_2^* b_1 = \eta, \quad (8.772)$$

one finds that

$$\begin{aligned}
 \frac{\langle O_- | O_+ \rangle}{\sqrt{\frac{1-k_z^2}{1-|\mathbf{k}|^2}}} &= \langle 2o | 2o \rangle - \langle 1o | 1o \rangle + \langle 2o | 1o \rangle \frac{k_x + ik_y}{|\mathbf{k}| - k_z} - \langle 1o | 2o \rangle \frac{k_x - ik_y}{|\mathbf{k}| + k_z} \\
 &= -2\kappa + \eta \frac{k_x + ik_y}{|\mathbf{k}| - k_z} - \eta^* \frac{k_x - ik_y}{|\mathbf{k}| + k_z} \\
 &= -2\frac{k_z}{2} + \frac{k_x - ik_y}{2} \frac{k_x + ik_y}{|\mathbf{k}| - k_z} - \frac{k_x + ik_y}{2} \frac{k_x - ik_y}{|\mathbf{k}| + k_z} \\
 &= -k_z + \frac{|\mathbf{k}|^2 - k_z^2}{2} \left(\frac{1}{|\mathbf{k}| - k_z} - \frac{1}{|\mathbf{k}| + k_z} \right) \\
 &= 0,
 \end{aligned} \tag{8.773}$$

and

$$\begin{aligned}
 \langle O_+ | O_+ \rangle &= \frac{(1+2\kappa) \left(1 + \frac{k_z}{|\mathbf{k}|}\right)}{2(1+|\mathbf{k}|)} + \frac{(1-2\kappa) \left(1 - \frac{k_z}{|\mathbf{k}|}\right)}{2(1+|\mathbf{k}|)} + \eta^* \frac{k_x - ik_y}{1+|\mathbf{k}|} + \eta \frac{k_x + ik_y}{1+|\mathbf{k}|} \\
 &= \frac{(1+k_z) \left(1 + \frac{k_z}{|\mathbf{k}|}\right)}{2(1+|\mathbf{k}|)} + \frac{(1-k_z) \left(1 - \frac{k_z}{|\mathbf{k}|}\right)}{2(1+|\mathbf{k}|)} + \frac{|\mathbf{k}| \left(1 - \frac{k_z^2}{|\mathbf{k}|^2}\right)}{1+|\mathbf{k}|} \\
 &= 1,
 \end{aligned}$$

$$\begin{aligned}
 \langle O_- | O_- \rangle &= \frac{(1+2\kappa) \left(1 - \frac{k_z}{|\mathbf{k}|}\right)}{2(1-|\mathbf{k}|)} + \frac{(1-2\kappa) \left(1 + \frac{k_z}{|\mathbf{k}|}\right)}{2(1-|\mathbf{k}|)} - \eta^* \frac{k_x - ik_y}{1-|\mathbf{k}|} - \eta \frac{k_x + ik_y}{1-|\mathbf{k}|} \\
 &= \frac{(1+k_z) \left(1 - \frac{k_z}{|\mathbf{k}|}\right)}{2(1-|\mathbf{k}|)} + \frac{(1-k_z) \left(1 + \frac{k_z}{|\mathbf{k}|}\right)}{2(1-|\mathbf{k}|)} - \frac{|\mathbf{k}| \left(1 - \frac{k_z^2}{|\mathbf{k}|^2}\right)}{1-|\mathbf{k}|} \\
 &= 1.
 \end{aligned}$$

and thus the states $|O_+\rangle$ and $|O_-\rangle$ are orthogonal to each other and normalized. Note also that [see Eqs. (8.750), (8.770), (8.771) and (8.772)]

$$\begin{aligned}
 |\mathbf{k}|^2 &= 4 \left(|\eta|^2 + \kappa^2 \right) \\
 &= 1 - 4 \left(\langle 1o | 1o \rangle \langle 2o | 2o \rangle - |\langle 2o | 1o \rangle|^2 \right),
 \end{aligned} \tag{8.774}$$

hence $|\mathbf{k}|^2 \leq 1$ [see the Schwartz inequality (2.172)]. Using the notation $N_1 = \langle 1o | 1o \rangle$ and $\cos^2 \vartheta = |\langle 2o | 1o \rangle|^2 / (\langle 1o | 1o \rangle \langle 2o | 2o \rangle)$ one has [note that $\langle 2o | 2o \rangle = 1 - N_1$ and $0 \leq N_1 \leq 1$, see Eq. (8.770)]

$$|\mathbf{k}|^2 = 1 - 4N_1(1 - N_1) \sin^2 \vartheta. \tag{8.775}$$

55. The matrix representation of \mathcal{H} in the basis $\{|--\rangle, |-\rangle, |+\rangle, |++\rangle\}$ is given by [see Eq. (6.710)], and note that \mathcal{H} has the same representation in the basis $\{|++\rangle, |+-\rangle, |-\rangle, |--\rangle\}$

$$H = \frac{\hbar\omega}{4} \begin{pmatrix} 1+\eta & 0 & 0 & 0 \\ 0 & -1-\eta & 2 & 0 \\ 0 & 2 & -1-\eta & 0 \\ 0 & 0 & 0 & 1+\eta \end{pmatrix}. \quad (8.776)$$

- a) With the help of Eq. (8.776) one finds that (recall that $|\psi\rangle$ is normalized)

$$\begin{aligned} \langle \mathcal{H} \rangle &= \frac{\hbar\omega}{4} (a^* \ b^* \ c^* \ d^*) \begin{pmatrix} 1+\eta & 0 & 0 & 0 \\ 0 & -1-\eta & 2 & 0 \\ 0 & 2 & -1-\eta & 0 \\ 0 & 0 & 0 & 1+\eta \end{pmatrix} \begin{pmatrix} a \\ b \\ c \\ d \end{pmatrix} \\ &= \frac{\hbar\omega ((a^*a - b^*b - c^*c + d^*d)(1+\eta) + 2(c^*b + b^*c))}{4} \\ &= \frac{\hbar\omega ((1 - 2(b^*b + c^*c))(1+\eta) + 2(c^*b + b^*c))}{4}. \end{aligned} \quad (8.777)$$

- b) The following holds

$$H = \frac{\hbar\omega}{4} U D U^{-1}, \quad (8.778)$$

where [see Eq. (6.712)]

$$U = \begin{pmatrix} 1 & 0 & 0 & 0 \\ 0 & \frac{1}{\sqrt{2}} & -\frac{1}{\sqrt{2}} & 0 \\ 0 & \frac{1}{\sqrt{2}} & \frac{1}{\sqrt{2}} & 0 \\ 0 & 0 & 0 & 1 \end{pmatrix}, \quad (8.779)$$

and

$$D = \begin{pmatrix} 1+\eta & 0 & 0 & 0 \\ 0 & 1-\eta & 0 & 0 \\ 0 & 0 & -3-\eta & 0 \\ 0 & 0 & 0 & 1+\eta \end{pmatrix}, \quad (8.780)$$

thus

$$\begin{aligned}
 \exp(-\beta H) &= U \left(\sum_{n=0}^{\infty} \frac{\left(-\frac{\hbar\omega\beta}{4} D\right)^n}{n!} \right) U^{-1} \\
 &= \begin{pmatrix} e^{-\frac{\hbar\omega\beta(1+\eta)}{4}} & 0 & 0 & 0 \\ 0 & \frac{e^{-\frac{\hbar\omega\beta(1-\eta)}{4}} + e^{\frac{\hbar\omega\beta(3+\eta)}{4}}}{2} & \frac{e^{-\frac{\hbar\omega\beta(1-\eta)}{4}} - e^{\frac{\hbar\omega\beta(3+\eta)}{4}}}{2} & 0 \\ 0 & \frac{e^{-\frac{\hbar\omega\beta(1-\eta)}{4}} - e^{\frac{\hbar\omega\beta(3+\eta)}{4}}}{2} & \frac{e^{-\frac{\hbar\omega\beta(1-\eta)}{4}} + e^{\frac{\hbar\omega\beta(3+\eta)}{4}}}{2} & 0 \\ 0 & 0 & 0 & e^{-\frac{\hbar\omega\beta(1+\eta)}{4}} \end{pmatrix}, \tag{8.781}
 \end{aligned}$$

hence [see Eq. (8.36)]

$$\rho \doteq \frac{\begin{pmatrix} e^{-\frac{\hbar\omega\beta(1+\eta)}{4}} & 0 & 0 & 0 \\ 0 & \frac{e^{-\frac{\hbar\omega\beta(1-\eta)}{4}} + e^{\frac{\hbar\omega\beta(3+\eta)}{4}}}{2} & \frac{e^{-\frac{\hbar\omega\beta(1-\eta)}{4}} - e^{\frac{\hbar\omega\beta(3+\eta)}{4}}}{2} & 0 \\ 0 & \frac{e^{-\frac{\hbar\omega\beta(1-\eta)}{4}} - e^{\frac{\hbar\omega\beta(3+\eta)}{4}}}{2} & \frac{e^{-\frac{\hbar\omega\beta(1-\eta)}{4}} + e^{\frac{\hbar\omega\beta(3+\eta)}{4}}}{2} & 0 \\ 0 & 0 & 0 & e^{-\frac{\hbar\omega\beta(1+\eta)}{4}} \end{pmatrix}}{2e^{-\frac{\hbar\omega\beta(1+\eta)}{4}} + e^{-\frac{\hbar\omega\beta(1-\eta)}{4}} + e^{\frac{\hbar\omega\beta(3+\eta)}{4}}}. \tag{8.782}$$

For the case $\eta = 0$

$$\rho \doteq \frac{1}{3e^{-\frac{\hbar\omega\beta}{4}} + e^{\frac{3\hbar\omega\beta}{4}}} \begin{pmatrix} e^{-\frac{\hbar\omega\beta}{4}} & 0 & 0 & 0 \\ 0 & \frac{e^{-\frac{\hbar\omega\beta}{4}} + e^{\frac{3\hbar\omega\beta}{4}}}{2} & \frac{e^{-\frac{\hbar\omega\beta}{4}} - e^{\frac{3\hbar\omega\beta}{4}}}{2} & 0 \\ 0 & \frac{e^{-\frac{\hbar\omega\beta}{4}} - e^{\frac{3\hbar\omega\beta}{4}}}{2} & \frac{e^{-\frac{\hbar\omega\beta}{4}} + e^{\frac{3\hbar\omega\beta}{4}}}{2} & 0 \\ 0 & 0 & 0 & e^{-\frac{\hbar\omega\beta}{4}} \end{pmatrix}. \tag{8.783}$$

With the help of Eq. (6.334) one finds that the matrix representation of the two-spin coherent state $|\hat{\mathbf{n}}_1, \hat{\mathbf{n}}_2\rangle$ is given by

$$|\hat{\mathbf{n}}_1, \hat{\mathbf{n}}_2\rangle \doteq U_2 U_1 \begin{pmatrix} 0 \\ 0 \\ 0 \\ 1 \end{pmatrix}, \tag{8.784}$$

where [compare with Eq. (8.726)]

$$U_1 = \begin{pmatrix} \cos \frac{\theta_1}{2} & 0 & -e^{-i\varphi_1} \sin \frac{\theta_1}{2} & 0 \\ 0 & \cos \frac{\theta_1}{2} & 0 & -e^{-i\varphi_1} \sin \frac{\theta_1}{2} \\ e^{i\varphi_1} \sin \frac{\theta_1}{2} & 0 & \cos \frac{\theta_1}{2} & 0 \\ 0 & e^{i\varphi_1} \sin \frac{\theta_1}{2} & 0 & \cos \frac{\theta_1}{2} \end{pmatrix}, \tag{8.785}$$

$$U_2 = \begin{pmatrix} \cos \frac{\theta_2}{2} & -e^{-i\varphi_2} \sin \frac{\theta_2}{2} & 0 & 0 \\ e^{i\varphi_2} \sin \frac{\theta_2}{2} & \cos \frac{\theta_2}{2} & 0 & 0 \\ 0 & 0 & \cos \frac{\theta_2}{2} & -e^{-i\varphi_2} \sin \frac{\theta_2}{2} \\ 0 & 0 & e^{i\varphi_2} \sin \frac{\theta_2}{2} & \cos \frac{\theta_2}{2} \end{pmatrix}, \quad (8.786)$$

thus

$$|\hat{\mathbf{n}}_1, \hat{\mathbf{n}}_2\rangle \doteq \begin{pmatrix} \frac{e^{-i(\varphi_1+\varphi_2)}(\cos(\frac{\theta_1-\theta_2}{2})-\cos(\frac{\theta_1+\theta_2}{2}))}{2} \\ \frac{e^{-i\varphi_1}(-\sin(\frac{\theta_1+\theta_2}{2})-\sin(\frac{\theta_1-\theta_2}{2}))}{2} \\ \frac{e^{-i\varphi_2}(-\sin(\frac{\theta_1+\theta_2}{2})+\sin(\frac{\theta_1-\theta_2}{2}))}{2} \\ \frac{\cos(\frac{\theta_1-\theta_2}{2})+\cos(\frac{\theta_1+\theta_2}{2})}{2} \end{pmatrix}, \quad (8.787)$$

hence for the case $\eta = 0$

$$\langle \hat{\mathbf{n}}_1, \hat{\mathbf{n}}_2 | \rho | \hat{\mathbf{n}}_1, \hat{\mathbf{n}}_2 \rangle = \frac{1}{4} \left(1 - (\cos \theta_1 \cos \theta_2 + \sin \theta_1 \sin \theta_2 \cos(\varphi_2 - \varphi_1)) \frac{1 - e^{-\hbar\omega\beta}}{1 + 3e^{-\hbar\omega\beta}} \right), \quad (8.788)$$

or

$$\langle \hat{\mathbf{n}}_1, \hat{\mathbf{n}}_2 | \rho | \hat{\mathbf{n}}_1, \hat{\mathbf{n}}_2 \rangle = \frac{1}{4} \left(1 - \hat{\mathbf{n}}_1 \cdot \hat{\mathbf{n}}_2 \frac{1 - e^{-\hbar\omega\beta}}{1 + 3e^{-\hbar\omega\beta}} \right). \quad (8.789)$$

56. The matrix element $(k'_1, k'_2), (k''_1, k''_2)$ of the reduced density operator ρ_{12} is given by

$$(\rho_{12})_{(k'_1, k'_2), (k''_1, k''_2)} = \sum_{k_3=1}^{N_3} C_{(k'_1, k'_2, k_3)} C_{(k''_1, k''_2, k_3)}^*. \quad (8.790)$$

a) Note that (recall that $|\psi\rangle$ is normalized)

$$\text{Tr}(\rho_{12}) = \sum_{k_1=1}^{N_1} \sum_{k_2=1}^{N_2} \sum_{k_3=1}^{N_3} \left| C_{(k_1, k_2, k_3)} \right|^2 = \langle \psi | \psi \rangle = 1, \quad (8.791)$$

and

$$(\rho_{12}^2)_{(k'_1, k'_2), (k''_1, k''_2)} = \sum_{k''_1=1}^{N_1} \sum_{k''_2=1}^{N_2} (\rho_{12})_{(k'_1, k'_2), (k''_1, k''_2)} (\rho_{12})_{(k''_1, k''_2), (k'_1, k'_2)}, \quad (8.792)$$

thus the following holds

$$\begin{aligned} 1 - P_{12} &= (\text{Tr}(\rho_{12}))^2 - \text{Tr}(\rho_{12}^2) \\ &= \sum_{k'_1, k''_1=1}^{N_1} \sum_{k'_2, k''_2=1}^{N_2} \sum_{k'_3, k''_3=1}^{N_3} \zeta_{k'_1, k'_2, k'_3, k''_1, k''_2, k''_3}, \end{aligned} \quad (8.793)$$

where

$$\begin{aligned} & \zeta_{k'_1, k'_2, k'_3, k''_1, k''_2, k''_3} \\ &= C_{(k'_1, k'_2, k'_3)} C_{(k''_1, k''_2, k''_3)} \left(C_{(k'_1, k'_2, k'_3)}^* C_{(k''_1, k''_2, k''_3)}^* - C_{(k'_1, k'_2, k'_3)}^* C_{(k''_1, k''_2, k''_3)}^* \right). \end{aligned} \quad (8.794)$$

The following holds

$$\zeta_{k'_1, k'_2, k'_3, k''_1, k''_2, k''_3} = 0, \quad (8.795)$$

$$\zeta_{k'_1, k'_2, k'_3, k''_1, k''_2, k''_3} = 0, \quad (8.796)$$

and

$$\begin{aligned} & \zeta_{k'_1, k'_2, k'_3, k''_1, k''_2, k''_3} + \zeta_{k''_1, k''_2, k''_3, k'_1, k'_2, k'_3} \\ &= \left| C_{(k'_1, k'_2, k'_3)} C_{(k''_1, k''_2, k''_3)} - C_{(k''_1, k''_2, k''_3)} C_{(k'_1, k'_2, k'_3)} \right|^2, \end{aligned} \quad (8.797)$$

hence

$$\begin{aligned} 1 - P_{12} &= \sum_{\substack{(k'_1, k'_2) \neq (k''_1, k''_2) \\ k'_3 \neq k''_3}} \frac{\zeta_{k'_1, k'_2, k'_3, k''_1, k''_2, k''_3} + \zeta_{k''_1, k''_2, k''_3, k'_1, k'_2, k'_3}}{2} \\ &= \sum_{\substack{(k'_1, k'_2) \neq (k''_1, k''_2) \\ k'_3 \neq k''_3}} \frac{\left| C_{(k'_1, k'_2, k'_3)} C_{(k''_1, k''_2, k''_3)} - C_{(k''_1, k''_2, k''_3)} C_{(k'_1, k'_2, k'_3)} \right|^2}{2}. \end{aligned} \quad (8.798)$$

Note that [see Eqs. (8.132) and (8.136)]

$$C_{\bar{k}_a} C_{\bar{k}_d} - C_{\bar{k}_b} C_{\bar{k}_c} = \frac{\langle \Psi_{\bar{k}_a, \bar{k}_b, \bar{k}_c, \bar{k}_d} | \psi \rangle}{2},$$

hence Eq. (8.133) holds.

b) The matrix representation of ρ_{12} in the spin 1 and 2 basis $\{|00\rangle, |01\rangle, |10\rangle, |11\rangle\}$ is given by

$$\begin{aligned} \rho_{12} &\doteq \begin{pmatrix} a_{000} \\ a_{001} \\ a_{010} \\ a_{011} \end{pmatrix} \begin{pmatrix} a_{000}^* & a_{001}^* & a_{010}^* & a_{011}^* \end{pmatrix} \\ &+ \begin{pmatrix} a_{100} \\ a_{101} \\ a_{110} \\ a_{111} \end{pmatrix} \begin{pmatrix} a_{100}^* & a_{101}^* & a_{110}^* & a_{111}^* \end{pmatrix}, \end{aligned} \quad (8.799)$$

thus

$$\begin{aligned}
 \frac{1 - P_{12}}{2} &= \frac{(\text{Tr}(\rho_{12}))^2 - \text{Tr}(\rho_{12}^2)}{2} \\
 &= |a_{000}a_{101} - a_{100}a_{001}|^2 + |a_{000}a_{110} - a_{100}a_{010}|^2 \\
 &\quad + |a_{000}a_{111} - a_{100}a_{011}|^2 + |a_{001}a_{110} - a_{101}a_{010}|^2 \\
 &\quad + |a_{001}a_{111} - a_{101}a_{011}|^2 + |a_{010}a_{111} - a_{110}a_{011}|^2 .
 \end{aligned} \tag{8.800}$$

c) For the GHZ state, the matrix representation of ρ_1 is given by

$$\begin{aligned}
 \rho_1 &\doteq \begin{pmatrix} -\frac{1}{\sqrt{2}} \\ 0 \end{pmatrix} \begin{pmatrix} -\frac{1}{\sqrt{2}} & 0 \end{pmatrix} + \begin{pmatrix} 0 \\ \frac{1}{\sqrt{2}} \end{pmatrix} \begin{pmatrix} 0 & \frac{1}{\sqrt{2}} \end{pmatrix} \\
 &= \begin{pmatrix} \frac{1}{2} & 0 \\ 0 & \frac{1}{2} \end{pmatrix} ,
 \end{aligned} \tag{8.801}$$

the corresponding purity is given by $P_1 = 1/2$, the matrix representation of ρ_{12} is given by

$$\rho_{12} \doteq \begin{pmatrix} \frac{1}{2} & 0 & 0 & 0 \\ 0 & 0 & 0 & 0 \\ 0 & 0 & 0 & 0 \\ 0 & 0 & 0 & \frac{1}{2} \end{pmatrix} , \tag{8.802}$$

and the corresponding purity is given $P_{12} = 1/2$. Recall that for a general N spin $1/2$ system (N is an integer), the density operator is represented by a $2^N \times 2^N$ matrix, and thus the purity is bounded between $1/2^N$ and 1, i.e. $1/2 \leq P_1 \leq 1$ and $1/4 \leq P_{12} \leq 1$.

57. The state $|\psi\rangle$ is given by [see Eq. (6.688)]

$$|\psi\rangle = \frac{|+, -\rangle - |-, +\rangle}{\sqrt{2}} , \tag{8.803}$$

hence $p = \sin^2(\theta/2)$ [see Eq. (6.304)].

58. In terms of the matrix elements $\rho_{n_1, n_2, m_1, m_2}$ of the operator ρ , which are given by

$$\rho_{(n_1, n_2), (m_1, m_2)} = \langle n_1, n_2 | \rho | m_1, m_2 \rangle , \tag{8.804}$$

the matrix elements of ρ_1 and ρ_2 are given by

$$(\rho_1)_{n_1, m_1} = \sum_{n_2} \rho_{(n_1, n_2), (m_1, n_2)} , \tag{8.805}$$

and

$$(\rho_2)_{n_2, m_2} = \sum_{n_1} \rho_{(n_1, n_2), (n_1, m_2)} . \quad (8.806)$$

In general ρ is Hermitian, i.e.

$$\left(\rho_{(n_1, n_2), (m_1, n_2)} \right)^* = \rho_{(m_1, n_2), (n_1, n_2)} , \quad (8.807)$$

and therefore

$$\begin{aligned} \left((\rho_1)_{n_1, m_1} \right)^* &= \sum_{n_2} \left(\rho_{(n_1, n_2), (m_1, n_2)} \right)^* \\ &= \sum_{n_2} \rho_{(m_1, n_2), (n_1, n_2)} \\ &= (\rho_1)_{m_1, n_1} , \end{aligned} \quad (8.808)$$

i.e. ρ_1 is also Hermitian, and similarly ρ_2 is also Hermitian. Thus the eigenvalues of ρ_1 and ρ_2 are all real. Moreover, these eigenvalues represent probabilities, and therefore they are expected to be all nonnegative and smaller than unity. In what follows it is assumed that the set of vectors $\{|n_1\rangle_1\}$ ($\{|n_2\rangle_2\}$) are chosen to be eigenvectors of the operator ρ_1 (ρ_2). Thus ρ_1 and ρ_2 can be expressed as

$$\rho_1 = \sum_{n_1} w_{n_1}^{(1)} |n_1\rangle_1 \langle n_1| , \quad (8.809)$$

and

$$\rho_2 = \sum_{n_2} w_{n_2}^{(2)} |n_2\rangle_2 \langle n_2| , \quad (8.810)$$

where the eigenvalues satisfy $0 \leq w_{n_1}^{(1)} \leq 1$ and $0 \leq w_{n_2}^{(2)} \leq 1$. Similarly, ρ can be diagonalized as

$$\rho = \sum_k w_k |k\rangle \langle k| , \quad (8.811)$$

where $0 \leq w_k \leq 1$. In terms of these eigenvalues the entropies are given by

$$\sigma_1 = - \text{Tr}_1 (\rho_1 \log \rho_1) = - \sum_{n_1} w_{n_1}^{(1)} \log w_{n_1}^{(1)} , \quad (8.812)$$

$$\sigma_2 = - \text{Tr}_2 (\rho_2 \log \rho_2) = - \sum_{n_2} w_{n_2}^{(2)} \log w_{n_2}^{(2)} , \quad (8.813)$$

and

$$\sigma = - \text{Tr} (\rho \log \rho) = - \sum_k w_k \log w_k . \quad (8.814)$$

As can be seen from Eqs. (8.804), (8.805) and (8.809), the following holds

$$\begin{aligned}
 w_{n_1}^{(1)} &= (\rho_1)_{n_1, n_1} \\
 &= \sum_{n_2} \rho_{(n_1, n_2), (n_1, n_2)} \\
 &= \sum_{n_2} \langle n_1, n_2 | \rho | n_1, n_2 \rangle \\
 &= \sum_{n_2} \sum_k \langle n_1, n_2 | k \rangle w_k \langle k | n_1, n_2 \rangle ,
 \end{aligned} \tag{8.815}$$

thus

$$w_{n_1}^{(1)} = \sum_{n_2} w_{n_1, n_2} , \tag{8.816}$$

and similarly

$$w_{n_2}^{(2)} = \sum_{n_1} w_{n_1, n_2} , \tag{8.817}$$

where

$$w_{n_1, n_2} = \sum_k \langle n_1, n_2 | k \rangle w_k \langle k | n_1, n_2 \rangle . \tag{8.818}$$

Note that

$$\begin{aligned}
 \sum_{n_1, n_2} w_{n_1, n_2} &= \sum_k w_k \langle k | \left(\sum_{n_1, n_2} |n_1, n_2\rangle \langle n_1, n_2| \right) | k \rangle \\
 &= \sum_k w_k \langle k | k \rangle ,
 \end{aligned} \tag{8.819}$$

thus the normalization condition $\langle k | k \rangle = 1$ together with the requirement that

$$\text{Tr } \rho = \sum_k w_k = 1 , \tag{8.820}$$

imply that

$$\sum_{n_1, n_2} w_{n_1, n_2} = 1 , \tag{8.821}$$

i.e.

$$\text{Tr}_1 \rho_1 = \sum_{n_1} w_{n_1}^{(1)} = 1 , \tag{8.822}$$

and

$$\text{Tr}_2 \rho_2 = \sum_{n_2} w_{n_2}^{(2)} = 1 . \quad (8.823)$$

Consider the quantity $y \left(w_{n_1, n_2} / w_{n_1}^{(1)} w_{n_2}^{(2)} \right)$, where the function $y(x)$ is given by

$$y(x) = x \log x - x + 1 . \quad (8.824)$$

The following holds

$$\frac{dy}{dx} = \log x , \quad (8.825)$$

and

$$\frac{d^2y}{dx^2} = \frac{1}{x} , \quad (8.826)$$

thus the function $y(x)$ has a single stationary point at $x = 1$, which is a minima point. Moreover $y(1) = 0$, thus one concludes that

$$y(x) \geq 0 \quad (8.827)$$

for $x \geq 0$. For $x = w_{n_1, n_2} / w_{n_1}^{(1)} w_{n_2}^{(2)}$ the inequality (8.827) implies that

$$\frac{w_{n_1, n_2}}{w_{n_1}^{(1)} w_{n_2}^{(2)}} \log \frac{w_{n_1, n_2}}{w_{n_1}^{(1)} w_{n_2}^{(2)}} - \frac{w_{n_1, n_2}}{w_{n_1}^{(1)} w_{n_2}^{(2)}} + 1 \geq 0 . \quad (8.828)$$

Multiplying by $w_{n_1}^{(1)} w_{n_2}^{(2)}$ and summing over n_1 and n_2 yields

$$\sum_{n_1, n_2} w_{n_1, n_2} \log \frac{w_{n_1, n_2}}{w_{n_1}^{(1)} w_{n_2}^{(2)}} - \sum_{n_1, n_2} w_{n_1, n_2} + \sum_{n_1} w_{n_1}^{(1)} \sum_{n_2} w_{n_2}^{(2)} \geq 0 , \quad (8.829)$$

thus with the help of Eqs. (8.821), (8.822) and (8.823) one finds that

$$\sum_{n_1, n_2} w_{n_1, n_2} \log \frac{w_{n_1, n_2}}{w_{n_1}^{(1)} w_{n_2}^{(2)}} \geq 0 , \quad (8.830)$$

and with the help of Eqs. (8.812) and (8.813) that

$$\sigma_1 + \sigma_2 \geq - \sum_{n_1, n_2} w_{n_1, n_2} \log w_{n_1, n_2} . \quad (8.831)$$

Using Eq. (8.818) one obtains

$$\begin{aligned}
& - \sum_{n_1, n_2} w_{n_1, n_2} \log w_{n_1, n_2} \\
&= \sum_{n_1, n_2} \sum_k |\langle n_1, n_2 | k \rangle|^2 w_k \log \frac{1}{w_{n_1, n_2}} \\
&= \sum_{n_1, n_2} \left(\sum_k |\langle n_1, n_2 | k \rangle|^2 w_k \log \frac{w_k}{w_{n_1, n_2}} \right) \\
&\quad - \sum_{n_1, n_2} \sum_k |\langle n_1, n_2 | k \rangle|^2 w_k \log w_k \\
&= \sum_{n_1, n_2} \left(\sum_k |\langle n_1, n_2 | k \rangle|^2 w_k \log \frac{w_k}{w_{n_1, n_2}} \right) \\
&\quad - \sum_k w_k \log w_k \underbrace{\sum_{n_1, n_2} |\langle n_1, n_2 | k \rangle|^2}_{=1},
\end{aligned} \tag{8.832}$$

thus

$$\begin{aligned}
& - \sum_{n_1, n_2} w_{n_1, n_2} \log w_{n_1, n_2} \\
&= \sum_{n_1, n_2} \left(\sum_k |\langle n_1, n_2 | k \rangle|^2 w_k \log \frac{w_k}{w_{n_1, n_2}} \right) \\
&\quad + \sigma.
\end{aligned} \tag{8.833}$$

Furthermore, according to inequality (8.827) the following holds

$$\begin{aligned}
& \sum_k |\langle n_1, n_2 | k \rangle|^2 w_k \log \frac{w_k}{w_{n_1, n_2}} \\
&= \sum_k |\langle n_1, n_2 | k \rangle|^2 w_{n_1, n_2} \frac{w_k}{w_{n_1, n_2}} \log \frac{w_k}{w_{n_1, n_2}} \\
&\geq \sum_k |\langle n_1, n_2 | k \rangle|^2 w_{n_1, n_2} \left(\frac{w_k}{w_{n_1, n_2}} - 1 \right), \\
&\quad \sum_k |\langle n_1, n_2 | k \rangle|^2 w_k - w_{n_1, n_2} \sum_k |\langle n_1, n_2 | k \rangle|^2 \\
&= 0.
\end{aligned} \tag{8.834}$$

These results together with inequality (8.831) yield

$$\sigma_1 + \sigma_2 \geq \sigma. \tag{8.835}$$

59. With the help of the identities

$$\log(1-x) = -\sum_{n=1}^{\infty} \frac{x^n}{n}, \quad (8.836)$$

and

$$\sum_{n=1}^{\infty} \frac{\gamma^{2n}}{2n} = \log \frac{1}{\sqrt{1-\gamma^2}}, \quad (8.837)$$

$$\sum_{n=0}^{\infty} \frac{\gamma^{2n+1}}{2n+1} = \log \sqrt{\frac{1+\gamma}{1-\gamma}}, \quad (8.838)$$

one finds that [note that $(\hat{\mathbf{n}} \cdot \boldsymbol{\sigma})^n = 1$ for n even]

$$\begin{aligned} S &= \log 2 + \sum_{n=1}^{\infty} \frac{(-\gamma \hat{\mathbf{n}} \cdot \boldsymbol{\sigma})^n}{n} \\ &= \log 2 - \hat{\mathbf{n}} \cdot \boldsymbol{\sigma} \sum_{n=0}^{\infty} \frac{\gamma^{2n+1}}{2n+1} + \sum_{n=1}^{\infty} \frac{\gamma^{2n}}{2n} \\ &= \log \frac{2}{\sqrt{1-\gamma^2}} + \hat{\mathbf{n}} \cdot \boldsymbol{\sigma} \log \sqrt{\frac{1-\gamma}{1+\gamma}}. \\ &= -\frac{1-\hat{\mathbf{n}} \cdot \boldsymbol{\sigma}}{2} \log \frac{1-\gamma}{2} - \frac{1+\hat{\mathbf{n}} \cdot \boldsymbol{\sigma}}{2} \log \frac{1+\gamma}{2}. \end{aligned} \quad (8.839)$$

Note that the following holds [recall that $\text{Tr}(\hat{\mathbf{n}} \cdot \boldsymbol{\sigma}) = 0$, and compare with Eq. (8.582)]

$$\text{Tr}(\rho S) = -\frac{1-\gamma}{2} \log \frac{1-\gamma}{2} - \frac{1+\gamma}{2} \log \frac{1+\gamma}{2}. \quad (8.840)$$

60. With the help of Eq. (8.194), which is given by

$$\rho = \frac{e^{-\mathcal{H}\beta}}{\text{Tr}(e^{-\mathcal{H}\beta})} = p_+ |+\rangle \langle +| + p_- |-\rangle \langle -|, \quad (8.841)$$

where the probabilities p_+ and p_- are given by

$$p_{\pm} = \frac{e^{\mp \frac{\hbar\omega\beta}{2}}}{e^{-\frac{\hbar\omega\beta}{2}} + e^{\frac{\hbar\omega\beta}{2}}}, \quad (8.842)$$

$\omega = |e|B/m_e c$ is the Larmor frequency [see Eq. (4.22)] and where $\beta = 1/(k_B T)$, one finds that

$$\begin{aligned} \sigma &= -p_+ \log p_+ - p_- \log p_- \\ &= -\frac{1-\tanh \frac{\hbar\omega\beta}{2}}{2} \log \frac{1-\tanh \frac{\hbar\omega\beta}{2}}{2} - \frac{1+\tanh \frac{\hbar\omega\beta}{2}}{2} \log \frac{1+\tanh \frac{\hbar\omega\beta}{2}}{2}. \end{aligned} \quad (8.843)$$

61. With the help of Eqs. (6.77) and (8.593) one finds that

$$\langle H | S_z | H \rangle = \frac{\hbar}{2\sqrt{2}}, \quad (8.844)$$

thus

$$p_{z+} - (1 - p_{z+}) = \frac{1}{\sqrt{2}}, \quad (8.845)$$

and therefore

$$p_{z+} = \cos^2 \frac{\pi}{8}. \quad (8.846)$$

62. The density operator is given by [see Eq. (8.262)]

$$\rho = (1 - e^{-\beta\hbar\omega}) \sum_{n=0}^{\infty} e^{-n\beta\hbar\omega} |n\rangle \langle n|, \quad (8.847)$$

where $\beta = 1/(k_B T)$, thus

$$\begin{aligned} \sigma &= -\text{Tr}(\rho \log \rho) \\ &= -\sum_{n=0}^{\infty} (1 - e^{-\beta\hbar\omega}) e^{-n\beta\hbar\omega} \log((1 - e^{-\beta\hbar\omega}) e^{-n\beta\hbar\omega}) \\ &= -(1 - e^{-\beta\hbar\omega}) \log(1 - e^{-\beta\hbar\omega}) \sum_{n=0}^{\infty} e^{-n\beta\hbar\omega} \\ &\quad + \beta\hbar\omega (1 - e^{-\beta\hbar\omega}) \sum_{n=0}^{\infty} n e^{-n\beta\hbar\omega}. \end{aligned} \quad (8.848)$$

By using the relations

$$\sum_{n=0}^{\infty} e^{-n\beta\hbar\omega} = \frac{1}{1 - e^{-\beta\hbar\omega}}, \quad (8.849)$$

and [see Eq. (8.251)]

$$\sum_{n=0}^{\infty} n e^{-n\beta\hbar\omega} = -\frac{1}{\hbar\omega} \frac{\partial}{\partial \beta} \sum_{n=0}^{\infty} e^{-n\beta\hbar\omega} = \frac{e^{-\beta\hbar\omega}}{(1 - e^{-\beta\hbar\omega})^2}, \quad (8.850)$$

one finds that

$$\sigma = -\log(1 - e^{-\beta\hbar\omega}) + \frac{\beta\hbar\omega}{e^{\beta\hbar\omega} - 1}. \quad (8.851)$$

63. The relation $\pi Q(\alpha) = \langle \alpha | \rho | \alpha \rangle$ [see Eq. (8.83)] implies that [see Eq. (8.20)]

$$0 \leq \pi Q(\alpha) \leq 1 . \quad (8.852)$$

Moreover, the normalization condition $\text{Tr} \rho = 1$ together with Eq. (5.87), which states that $\text{Tr} A = \pi^{-1} \int d^2 \alpha' \langle \alpha' | A | \alpha' \rangle$ for a general operator A , yield

$$1 = \int d^2 \alpha' Q(\alpha) . \quad (8.853)$$

- a) Consider the function $f(x) = -x \log x$. The following holds $\lim_{x \rightarrow 0} f(x) = \lim_{x \rightarrow 1} f(x) = 0$, $df/dx = -\log x - 1$, and $d^2 f/dx^2 = -1/x$. These relations imply that $f(x) \geq 0$ in the range $x \in [0, 1]$, and thus $\sigma_W \geq 0$ [see Eq. (8.852)].

- b) For a coherent state $\rho = |\alpha\rangle\langle\alpha|$, Eq. (8.83) yields $Q(\alpha') = \pi^{-1} |\langle\alpha|\alpha'\rangle|^2 = \pi^{-1} \exp(-|\alpha - \alpha'|^2)$ [see Eq. (5.252)], and thus Eq. (8.150) yields

$$\begin{aligned} \sigma_W &= \frac{1}{\pi} \int d^2 \alpha' e^{-|\alpha - \alpha'|^2} |\alpha - \alpha'|^2 \\ &= 2 \int_0^\infty dr r^3 e^{-r^2} \\ &= 1 . \end{aligned} \quad (8.854)$$

- c) For a number state $\rho = |n\rangle\langle n|$ [see Eqs. (8.83) and (5.42)]

$$Q(\alpha') = \frac{e^{-|\alpha'|^2} |\alpha'|^{2n}}{\pi n!} ,$$

and thus Eq. (8.150) yields

$$\begin{aligned} \sigma_W &= - \int d^2 \alpha' \frac{e^{-|\alpha'|^2} |\alpha'|^{2n}}{\pi n!} \log \left(\frac{e^{-|\alpha'|^2} |\alpha'|^{2n}}{n!} \right) \\ &= 2\pi \int_0^\infty dr r \frac{e^{-r^2} r^{2n}}{\pi n!} \left(r^2 - \log \left(\frac{r^{2n}}{n!} \right) \right) \\ &= n - n\psi(n) + \log(\Gamma(n+1)) , \end{aligned} \quad (8.855)$$

where Γ denoted the gamma function $\Gamma(z) = \int_0^\infty dt e^{-t} t^{z-1}$, and ψ denotes the psi function $\psi(z) = d \log \Gamma(z) / dz$. Note that $\sigma_W = 1$ for $n = 0$.

- d) For a thermal state [see Eqs. (8.83), (5.42) and (8.266)]

$$Q(\alpha') = \frac{1}{\pi} \frac{1}{\langle N \rangle + 1} \sum_{n=0}^{\infty} \left(\frac{\langle N \rangle}{\langle N \rangle + 1} \right)^n |\langle n | \alpha \rangle|^2 \quad (8.856)$$

$$= \frac{e^{-|\alpha'|^2}}{\pi} \frac{1}{\langle N \rangle + 1} \sum_{n=0}^{\infty} \frac{\left(\frac{\langle N \rangle}{\langle N \rangle + 1} |\alpha'|^2 \right)^n}{n!} \quad (8.857)$$

$$= \frac{1}{\pi} \frac{1}{\langle N \rangle + 1} e^{-\frac{|\alpha'|^2}{\langle N \rangle + 1}}, \quad (8.858)$$

where

$$\langle N \rangle = \frac{e^{-\beta \hbar \omega}}{1 - e^{-\beta \hbar \omega}}, \quad (8.859)$$

is the expectation value of the number operator N , and $\beta = 1/(k_B T)$, thus

$$\begin{aligned} \sigma_W &= \frac{2}{\langle N \rangle + 1} \int_0^{\infty} dr r e^{-\frac{r^2}{\langle N \rangle + 1}} \left(\frac{r^2}{\langle N \rangle + 1} + \log(\langle N \rangle + 1) \right) \\ &= 1 + \ln(\langle N \rangle + 1), \end{aligned} \quad (8.860)$$

Note that in the zero temperature limit (i.e. when $\langle N \rangle = 0$) $\sigma_W = 1$, and in the high temperature limit (i.e. when $\langle N \rangle = (\beta \hbar \omega)^{-1} \gg 1$) $\sigma_W = 1 + \ln(1/(\beta \hbar \omega))$ [compare with Eq. (8.851)].

64. Let $\sigma_n \in \{0, 1\}$ be the outcome of the measurement of the projector P at time t_n , and let $p(\sigma_{n+1} = 1 | \sigma_n = 1)$ be the probability that the measurement at time t_{n+1} yields the value $\sigma_{n+1} = 1$ given that the previous measurement at time t_n has yielded the value $\sigma_n = 1$. The density operator $\rho_{n,+}$ immediately after the measurement at time t_n is related to the density operator $\rho_{n,-}$ immediately before the measurement at time t_n by [see Eq. (8.297)]

$$\rho_{n,+} = \frac{R_n}{\text{Tr}(R_n)}, \quad (8.861)$$

where

$$R_n = P \rho_{n,-} P, \quad (8.862)$$

and thus [see Eqs. (4.9), (8.10) and (8.31)]

$$p(\sigma_{n+1} = 1 | \sigma_n = 1) = \text{Tr}(\mathcal{U} \rho_{n,+} \mathcal{U}^\dagger P) = \frac{\text{Tr}(\mathcal{U} R_n \mathcal{U}^\dagger P)}{\text{Tr}(R_n)}, \quad (8.863)$$

where

$$\mathcal{U} = \exp\left(-\frac{i\mathcal{H}t}{\hbar}\right). \quad (8.864)$$

To second order in $1/N$ one has [see Eq. (2.182)]

$$\begin{aligned} \mathcal{U}R_n\mathcal{U}^\dagger &= R_n - \frac{it}{N\hbar} [\mathcal{H}, R_n] - \frac{1}{2} \left(\frac{t}{N\hbar} \right)^2 [\mathcal{H}, [\mathcal{H}, R_n]] \\ &\quad + O\left(\frac{1}{N^3}\right), \end{aligned} \tag{8.865}$$

and the following holds [recall that $P^2 = P$ and Eq. (2.134)]

$$\text{Tr}([\mathcal{H}, R_n]P) = \text{Tr}(\mathcal{H}P\rho_{n,-}PP - P\rho_{n,-}P\mathcal{H}P) = 0, \tag{8.866}$$

thus

$$p(\sigma_{n+1} = 1 | \sigma_n = 1) = 1 - \frac{1}{2} \left(\frac{t}{N\hbar} \right)^2 \frac{\text{Tr}([\mathcal{H}, [\mathcal{H}, R_n]]P)}{\text{Tr}(R_n)} + O\left(\frac{1}{N^3}\right). \tag{8.867}$$

The above result implies that in the limit $N \rightarrow \infty$ the probability p_{same} that $\sigma_n = 1$ for all $n \geq 1$ given that $\sigma_0 = 1$ is given by

$$p_{\text{same}} = \lim_{N \rightarrow \infty} (p(\sigma_{n+1} = 1 | \sigma_n = 1))^N = 1. \tag{8.868}$$

This results demonstrates the so-called Zeno effect [compare with Eq. (6.513)]. The time evolution in the limit $N \rightarrow \infty$ is evaluated by assuming that $\sigma_n = 1$ for all n . Under that assumption the density operator immediately after the final measurement at time $t_n = t$ is

$$\rho_{N,+} = \frac{(P\mathcal{U}P)^N \rho_{0,-} (P\mathcal{U}^\dagger P)^N}{\text{Tr}\left((P\mathcal{U}P)^N \rho_{0,-} (P\mathcal{U}^\dagger P)^N\right)}. \tag{8.869}$$

The following holds [recall that $P^2 = P$]

$$\begin{aligned} \lim_{N \rightarrow \infty} (P\mathcal{U}P)^N &= \lim_{N \rightarrow \infty} \left(\left(1 - \frac{iP\mathcal{H}Pt}{N\hbar} + O\left(\frac{1}{N^2}\right) \right) P \right)^N \\ &= \exp\left(-\frac{iP\mathcal{H}Pt}{\hbar}\right) P \\ &= u_{\text{eff}}(t) P, \end{aligned} \tag{8.870}$$

where

$$u_{\text{eff}}(t) = \exp\left(-\frac{i\mathcal{H}_{\text{eff}}t}{\hbar}\right), \tag{8.871}$$

and where

$$\mathcal{H}_{\text{eff}} = P\mathcal{H}P, \tag{8.872}$$

and thus in the limit $N \rightarrow \infty$ (note that $u_{\text{eff}}(t)$ is unitary)

$$\rho_{N,+} = u_{\text{eff}}(t) \rho_{0,+} u_{\text{eff}}^\dagger(t) . \quad (8.873)$$

65. Note that $\text{Tr}(C^T C) = \sum_{n,m} C_{n,m}^2$. The result (8.153) is obtained from the definition (8.152) using Eqs. (6.700) and (6.701). Note that τ , which represents the spin-spin entanglement, is bounded by $0 \leq \tau \leq 1$ (since $\langle \psi | \psi \rangle = 1$ and $0 \leq |\langle \psi_F | \psi \rangle|^2 \leq 1$).

66. With the help of the identity

$$\text{Tr} \left(\begin{pmatrix} x_{00}^* & x_{10}^* \\ x_{01}^* & x_{11}^* \end{pmatrix} \begin{pmatrix} y_{00} & y_{01} \\ y_{10} & y_{11} \end{pmatrix} \right) = x_{00}^* y_{00} + x_{01}^* y_{01} + x_{10}^* y_{10} + x_{11}^* y_{11} , \quad (8.874)$$

one finds that

$$\text{Tr} \left(M_0^\dagger M_0 + M_1^\dagger M_1 \right) = \langle \psi | \psi \rangle . \quad (8.875)$$

The matrix tensor product $C \otimes B \otimes A$ is given by [see Eqs. (8.164), (8.165) and (8.166)]

$$\begin{aligned} C \otimes B \otimes A &= \left(\begin{array}{c|c} c_{11}(B \otimes A) & c_{12}(B \otimes A) \\ \hline c_{21}(B \otimes A) & c_{22}(B \otimes A) \end{array} \right) \\ &= \left(\begin{array}{c|c} c_{11} \left(\begin{array}{c|c} b_{11}A & b_{12}A \\ \hline b_{21}A & b_{22}A \end{array} \right) & c_{12} \left(\begin{array}{c|c} b_{11}A & b_{12}A \\ \hline b_{21}A & b_{22}A \end{array} \right) \\ \hline c_{21} \left(\begin{array}{c|c} b_{11}A & b_{12}A \\ \hline b_{21}A & b_{22}A \end{array} \right) & c_{22} \left(\begin{array}{c|c} b_{11}A & b_{12}A \\ \hline b_{21}A & b_{22}A \end{array} \right) \end{array} \right) \\ &= \begin{pmatrix} c_{11}b_{11}a_{11} & c_{11}b_{11}a_{12} & c_{11}b_{12}a_{11} & c_{11}b_{12}a_{12} & c_{12}b_{11}a_{11} & c_{12}b_{11}a_{12} & c_{12}b_{12}a_{11} & c_{12}b_{12}a_{12} \\ c_{11}b_{11}a_{21} & c_{11}b_{11}a_{22} & c_{11}b_{12}a_{21} & c_{11}b_{12}a_{22} & c_{12}b_{11}a_{21} & c_{12}b_{11}a_{22} & c_{12}b_{12}a_{21} & c_{12}b_{12}a_{22} \\ c_{11}b_{21}a_{11} & c_{11}b_{21}a_{12} & c_{11}b_{22}a_{11} & c_{11}b_{22}a_{12} & c_{12}b_{21}a_{11} & c_{12}b_{21}a_{12} & c_{12}b_{22}a_{11} & c_{12}b_{22}a_{12} \\ c_{11}b_{21}a_{21} & c_{11}b_{21}a_{22} & c_{11}b_{22}a_{21} & c_{11}b_{22}a_{22} & c_{12}b_{21}a_{21} & c_{12}b_{21}a_{22} & c_{12}b_{22}a_{21} & c_{12}b_{22}a_{22} \\ c_{21}b_{11}a_{11} & c_{21}b_{11}a_{12} & c_{21}b_{12}a_{11} & c_{21}b_{12}a_{12} & c_{22}b_{11}a_{11} & c_{22}b_{11}a_{12} & c_{22}b_{12}a_{11} & c_{22}b_{12}a_{12} \\ c_{21}b_{11}a_{21} & c_{21}b_{11}a_{22} & c_{21}b_{12}a_{21} & c_{21}b_{12}a_{22} & c_{22}b_{11}a_{21} & c_{22}b_{11}a_{22} & c_{22}b_{12}a_{21} & c_{22}b_{12}a_{22} \\ c_{21}b_{21}a_{11} & c_{21}b_{21}a_{12} & c_{21}b_{22}a_{11} & c_{21}b_{22}a_{12} & c_{22}b_{21}a_{11} & c_{22}b_{21}a_{12} & c_{22}b_{22}a_{11} & c_{22}b_{22}a_{12} \\ c_{21}b_{21}a_{21} & c_{21}b_{21}a_{22} & c_{21}b_{22}a_{21} & c_{21}b_{22}a_{22} & c_{22}b_{21}a_{21} & c_{22}b_{21}a_{22} & c_{22}b_{22}a_{21} & c_{22}b_{22}a_{22} \end{pmatrix} . \end{aligned} \quad (8.876)$$

For the case $C = I$, one has in a block form [see Eq. (8.876)]

$$C \otimes B \otimes A = \left(\begin{array}{c|c} B \otimes A & 0 \\ \hline 0 & B \otimes A \end{array} \right) ,$$

where

$$B \otimes A = \begin{pmatrix} b_{11}a_{11} & b_{11}a_{12} & b_{12}a_{11} & b_{12}a_{12} \\ b_{11}a_{21} & b_{11}a_{22} & b_{12}a_{21} & b_{12}a_{22} \\ b_{21}a_{11} & b_{21}a_{12} & b_{22}a_{11} & b_{22}a_{12} \\ b_{21}a_{21} & b_{21}a_{22} & b_{22}a_{21} & b_{22}a_{22} \end{pmatrix} . \quad (8.877)$$

- a) The matrix representation of the reduced density operator $\rho_c = \text{Tr}_{a,b}(|\psi\rangle\langle\psi|)$ is given by

$$\rho_c \doteq \begin{pmatrix} q_{000}q_{000}^* + q_{001}q_{001}^* + q_{010}q_{010}^* + q_{011}q_{011}^* & q_{000}q_{100}^* + q_{001}q_{101}^* + q_{010}q_{110}^* + q_{011}q_{111}^* \\ q_{100}q_{000}^* + q_{101}q_{001}^* + q_{110}q_{010}^* + q_{111}q_{011}^* & q_{100}q_{100}^* + q_{101}q_{101}^* + q_{110}q_{110}^* + q_{111}q_{111}^* \end{pmatrix}, \quad (8.878)$$

thus Eq. (8.158) holds [see Eqs. (8.156), (8.157) and (8.874)].

- b) The result (8.159) is obtained using Eqs. (8.158) and (8.874).
c) The following hold [see Eq. (8.877)]

$$B \otimes A \begin{pmatrix} q_{000} \\ q_{001} \\ q_{010} \\ q_{011} \end{pmatrix} = \begin{pmatrix} b_{11}a_{11}q_{000} + b_{11}a_{12}q_{001} + b_{12}a_{11}q_{010} + b_{12}a_{12}q_{011} \\ b_{11}a_{21}q_{000} + b_{11}a_{22}q_{001} + b_{12}a_{21}q_{010} + b_{12}a_{22}q_{011} \\ b_{21}a_{11}q_{000} + b_{21}a_{12}q_{001} + b_{22}a_{11}q_{010} + b_{22}a_{12}q_{011} \\ b_{21}a_{21}q_{000} + b_{21}a_{22}q_{001} + b_{22}a_{21}q_{010} + b_{22}a_{22}q_{011} \end{pmatrix} \quad (8.879)$$

(8.880)

$$B \otimes A \begin{pmatrix} q_{100} \\ q_{101} \\ q_{110} \\ q_{111} \end{pmatrix} = \begin{pmatrix} b_{11}a_{11}q_{100} + b_{11}a_{12}q_{101} + b_{12}a_{11}q_{110} + b_{12}a_{12}q_{111} \\ b_{11}a_{21}q_{100} + b_{11}a_{22}q_{101} + b_{12}a_{21}q_{110} + b_{12}a_{22}q_{111} \\ b_{21}a_{11}q_{100} + b_{21}a_{12}q_{101} + b_{22}a_{11}q_{110} + b_{22}a_{12}q_{111} \\ b_{21}a_{21}q_{100} + b_{21}a_{22}q_{101} + b_{22}a_{21}q_{110} + b_{22}a_{22}q_{111} \end{pmatrix} \quad (8.881)$$

(8.882)

and [see Eqs. (8.156), (8.157), (8.164) and (8.165)]

$$BM_0A^T = \begin{bmatrix} b_{11}a_{11}q_{000} + b_{11}a_{12}q_{001} + b_{12}a_{11}q_{010} + b_{12}a_{12}q_{011} & b_{11}a_{21}q_{000} + b_{11}a_{22}q_{001} + b_{12}a_{21}q_{010} + b_{12}a_{22}q_{011} \\ b_{21}a_{11}q_{000} + b_{21}a_{12}q_{001} + b_{22}a_{11}q_{010} + b_{22}a_{12}q_{011} & b_{21}a_{21}q_{000} + b_{21}a_{22}q_{001} + b_{22}a_{21}q_{010} + b_{22}a_{22}q_{011} \end{bmatrix}, \quad (8.883)$$

$$BM_1A^T = \begin{bmatrix} b_{11}a_{11}q_{100} + b_{11}a_{12}q_{101} + b_{12}a_{11}q_{110} + b_{12}a_{12}q_{111} & b_{11}a_{21}q_{100} + b_{11}a_{22}q_{101} + b_{12}a_{21}q_{110} + b_{12}a_{22}q_{111} \\ b_{21}a_{11}q_{100} + b_{21}a_{12}q_{101} + b_{22}a_{11}q_{110} + b_{22}a_{12}q_{111} & b_{21}a_{21}q_{100} + b_{21}a_{22}q_{101} + b_{22}a_{21}q_{110} + b_{22}a_{22}q_{111} \end{bmatrix}, \quad (8.884)$$

thus Eq. (8.168) holds.

- d) The following holds [see Eqs. (8.156), (8.157), (8.168), (8.169) and (8.874)]

$$\begin{aligned}
Q(A, B) &= \text{Tr} \left(M_0^\dagger M_0 + M_1^\dagger M_1 \right) \text{Tr} \left(M_0^\dagger B M_0 A^T + M_1^\dagger B M_1 A^T \right) \\
&\quad - \text{Tr} \left(M_0^\dagger M_0 A^T + M_1^\dagger M_1 A^T \right) \text{Tr} \left(M_0^\dagger B M_0 + M_1^\dagger B M_1 \right) \\
&= \text{Tr} (S(I, I)) \text{Tr} (S(A, B)) - \text{Tr} (S(A, I)) \text{Tr} (S(I, B)) .
\end{aligned} \tag{8.885}$$

The result (8.170) is obtained using the matrix identity

$$\text{Tr} (X \otimes Y) = \text{Tr} (X) \text{Tr} (Y) . \tag{8.886}$$

- e) A general single spin unitary transformation can be represented by a 2×2 unitary matrix $u(\theta, \varphi)$ having the form [see Eqs. (6.301) and (6.302)]

$$u(\theta, \varphi) \doteq \begin{pmatrix} \cos \frac{\theta}{2} e^{-\frac{i\varphi}{2}} & -\sin \frac{\theta}{2} e^{-\frac{i\varphi}{2}} \\ \sin \frac{\theta}{2} e^{\frac{i\varphi}{2}} & \cos \frac{\theta}{2} e^{\frac{i\varphi}{2}} \end{pmatrix} , \tag{8.887}$$

where both θ and φ are real. Note that $\det u = \det u^T = 1$, and that $u^\dagger = u^{-1}$. A general time evolution generated by the Hamiltonian $\mathcal{H} = \mathcal{H}_a + \mathcal{H}_b$ gives rise to a pair transformation having the form given by Eq. (8.168), with $A = u_a \equiv u(\theta_a, \varphi_a)$ and $B = u_b \equiv u(\theta_b, \varphi_b)$, where the angles $\theta_a, \varphi_a, \theta_b$ and φ_b are all real, i.e.

$$(M_0, M_1) \rightarrow (u_b M_0 u_a^T, u_b M_1 u_a^T) . \tag{8.888}$$

The above relation (8.888) implies that $\det M_0 = \kappa_0 = q_{000}q_{011} - q_{001}q_{010}$, $\det M_1 = \kappa_1 = q_{100}q_{111} - q_{101}q_{110}$ and [see Eq. (2.134)] $\det (M_1) \text{Tr} (M_1^{-1} M_0) = \det (M_0) \text{Tr} (M_0^{-1} M_1) = \kappa_s = q_{000}q_{111} - q_{001}q_{110} - q_{010}q_{101} + q_{011}q_{100}$ are all time independent. Moreover $\text{Tr} (M_0 M_0^\dagger)$, $\text{Tr} (M_0 M_1^\dagger)$, $\text{Tr} (M_0^\dagger M_1)$ and $\text{Tr} (M_1 M_1^\dagger)$ are all time independent, thus ρ_c is time independent [see Eq. (8.158)].

- f) For the single spin unitary transformation u given by Eq. (8.887), the following holds

$$u^\dagger(\theta, \varphi) \begin{pmatrix} \sigma_1 \\ \sigma_2 \\ \sigma_3 \end{pmatrix} u(\theta, \varphi) = T(\theta, \varphi) \begin{pmatrix} \sigma_1 \\ \sigma_2 \\ \sigma_3 \end{pmatrix} , \tag{8.889}$$

where σ_1, σ_2 and σ_3 are Pauli matrices (6.137), and the 3×3 matrix T , which is given by

$$T(\theta, \varphi) = \begin{pmatrix} \cos \varphi \cos \theta - \sin \varphi \sin \theta \cos \varphi \\ \sin \varphi \cos \theta \cos \varphi \sin \theta \sin \varphi \\ -\sin \theta \quad 0 \quad \cos \theta \end{pmatrix} , \tag{8.890}$$

is orthonormal, i.e. [compare with Eqs. (8.186) and (8.187)]

$$T^T T = T T^T = 1. \quad (8.891)$$

The transformed variable $Q(A, B)$ is given by $Q\left(u_a^\dagger A u_a, u_b^\dagger B u_b\right)$ [see Eqs. (8.169) and (8.171)], and thus the transformed μ matrix, which is denoted by μ' , is given by [see Eq. (8.176)]

$$\mu' = \begin{pmatrix} Q\left(u_a^\dagger \sigma_1 u_a, u_b^\dagger \sigma_1 u_b\right) & Q\left(u_a^\dagger \sigma_1 u_a, u_b^\dagger \sigma_2 u_b\right) & Q\left(u_a^\dagger \sigma_1 u_a, u_b^\dagger \sigma_3 u_b\right) \\ Q\left(u_a^\dagger \sigma_2 u_a, u_b^\dagger \sigma_1 u_b\right) & Q\left(u_a^\dagger \sigma_2 u_a, u_b^\dagger \sigma_2 u_b\right) & Q\left(u_a^\dagger \sigma_2 u_a, u_b^\dagger \sigma_3 u_b\right) \\ Q\left(u_a^\dagger \sigma_3 u_a, u_b^\dagger \sigma_1 u_b\right) & Q\left(u_a^\dagger \sigma_3 u_a, u_b^\dagger \sigma_2 u_b\right) & Q\left(u_a^\dagger \sigma_3 u_a, u_b^\dagger \sigma_3 u_b\right) \end{pmatrix}. \quad (8.892)$$

The following holds [see Eqs. (8.889) and (8.169)]

$$\begin{aligned} (\mu')_{n_a, n_b} &= \sum_{n'_a=1}^3 \sum_{n'_b=1}^3 (T_a)_{n_a, n'_a} (T_b)_{n_b, n'_b} (\mu)_{n'_a, n'_b} \\ &= \sum_{n'_a=1}^3 \sum_{n'_b=1}^3 (T_a)_{n_a, n'_a} (\mu)_{n'_a, n'_b} (T_b^T)_{n'_b, n_b}, \end{aligned} \quad (8.893)$$

or in a matrix form

$$\mu' = T_a \mu T_b^T, \quad (8.894)$$

where $T_a = T(\theta_a, \varphi_a)$ and $T_b = T(\theta_b, \varphi_b)$. The relation (8.894) implies that the transformed value of $\tau_{a,b}$, which is denoted by $\tau'_{a,b}$, is given by [see Eqs. (2.134), (8.175), (8.891) and (8.894)]

$$\tau'_{a,b} = \frac{\text{Tr}(\mu'^T \mu')}{3} = \frac{\text{Tr}\left(\left(T_a \mu T_b^T\right)^T \left(T_a \mu T_b^T\right)\right)}{3} = \frac{\text{Tr}(\mu^T \mu)}{3}, \quad (8.895)$$

hence $\tau_{a,b}$ is time independent.

g) The values of $\tau_{a,b}$ are calculated using the definition (8.175).

67. Note that $\text{Tr} \lambda_0 = d_H$.

a) The Gell-Mann matrices are given by [compare with Eq. (6.137)]

$$\begin{aligned}
\lambda_1 &= \begin{pmatrix} 0 & 1 & 0 \\ 1 & 0 & 0 \\ 0 & 0 & 0 \end{pmatrix}, \lambda_2 = \begin{pmatrix} 0 & 0 & 1 \\ 0 & 0 & 0 \\ 1 & 0 & 0 \end{pmatrix}, \lambda_3 = \begin{pmatrix} 0 & 0 & 0 \\ 0 & 0 & 1 \\ 0 & 1 & 0 \end{pmatrix}, \\
\lambda_4 &= \begin{pmatrix} 0 & -i & 0 \\ i & 0 & 0 \\ 0 & 0 & 0 \end{pmatrix}, \lambda_5 = \begin{pmatrix} 0 & 0 & -i \\ 0 & 0 & 0 \\ i & 0 & 0 \end{pmatrix}, \lambda_6 = \begin{pmatrix} 0 & 0 & 0 \\ 0 & 0 & -i \\ 0 & i & 0 \end{pmatrix}, \\
\lambda_7 &= \begin{pmatrix} 1 & 0 & 0 \\ 0 & -1 & 0 \\ 0 & 0 & 0 \end{pmatrix}, \lambda_8 = \frac{1}{\sqrt{3}} \begin{pmatrix} 1 & 0 & 0 \\ 0 & 1 & 0 \\ 0 & 0 & -2 \end{pmatrix}.
\end{aligned} \tag{8.896}$$

b) Any $d_{\text{H}} \times d_{\text{H}}$ matrix M can be expanded as

$$M = m_0 \lambda_0 + \sum_{a=1}^{d_{\text{H}}^2 - 1} m_a \lambda_a, \tag{8.897}$$

and the following holds [recall that $\text{Tr} \lambda_a = 0$, and see Eq. (8.181)]

$$\text{Tr} M = m_0 d_{\text{H}} \tag{8.898}$$

$$\text{Tr} (\lambda_a M) = 2m_a \tag{8.899}$$

hence [see Eqs. (8.897)]

$$M = \frac{\text{Tr} M}{d_{\text{H}}} \lambda_0 + \sum_{a=1}^{d_{\text{H}}^2 - 1} \frac{\text{Tr} (\lambda_a M)}{2} \lambda_a, \tag{8.900}$$

thus the matrix elements $M_{n', n''}$ of M are given by

$$M_{n', n''} = \frac{\sum_{n'''} M_{n''', n'''} \delta_{n', n''}}{d_{\text{H}}} + \sum_{a=1}^{d_{\text{H}}^2 - 1} \frac{\sum_{n'''} \sum_{n''''} (\lambda_a)_{n''', n''''} M_{n''', n''''}}{2} (\lambda_a)_{n', n''}. \tag{8.901}$$

Using the relations

$$M_{n', n''} = \sum_{n'''} \sum_{n''''} \delta_{n', n''''} \delta_{n'', n'''} M_{n''', n''''}, \tag{8.902}$$

$$M_{n''', n''''} = \sum_{n''''} \delta_{n''', n''''} M_{n''', n''''}, \tag{8.903}$$

one finds that

$$0 = \sum_{n'''} \sum_{n''''} S_{n''', n''''} M_{n''', n''''}, \tag{8.904}$$

where

$$S_{n''',n''''} = \frac{\delta_{n',n''}\delta_{n''',n''''}}{d_{\text{H}}} + \sum_{a=1}^{d_{\text{H}}^2-1} \frac{(\lambda_a)_{n',n''}(\lambda_a)_{n''',n''''}}{2} - \delta_{n',n''''}\delta_{n'',n'''} . \quad (8.905)$$

Since M is arbitrary, $S_{n''',n''''} = 0$, thus Eq. (8.182) holds.

c) Note that [see Eqs. (8.181) and (8.183)]

$$\text{Tr}(\rho\lambda_b) = k_b . \quad (8.906)$$

The following holds [see Eqs. (8.29) and (8.183)]

$$\sum_{a'=1}^{d_{\text{H}}^2-1} \lambda_{a'} \frac{dk_{a'}}{dt} = i\hbar^{-1} \sum_{a'=1}^{d_{\text{H}}^2-1} [\lambda_{a'}, \mathcal{H}] k_{a'} . \quad (8.907)$$

Multiplying by λ_a and tracing yields [see Eqs. (8.181) and (2.134)]

$$\frac{dk_a}{dt} = \frac{i\hbar^{-1}}{2} \sum_{a'=1}^{d_{\text{H}}^2-1} \text{Tr}([\lambda_a, \lambda_{a'}] \mathcal{H}) k_{a'} . \quad (8.908)$$

In a vector form

$$\frac{d\bar{k}}{dt} = J\bar{k} , \quad (8.909)$$

where the element $(J)_{a',a''}$ of the $(d_{\text{H}}^2 - 1) \times (d_{\text{H}}^2 - 1)$ matrix J is given by

$$(J)_{a',a''} = \frac{i}{2\hbar} \text{Tr}([\lambda_{a'}, \lambda_{a''}] \mathcal{H}) . \quad (8.910)$$

The matrix J is real and antisymmetric provided that \mathcal{H} is Hermitian (note that $i[\lambda_{a'}, \lambda_{a''}]$ is Hermitian), hence

$$\bar{k} \cdot \frac{d\bar{k}}{dt} = \sum_{a'=1}^{d_{\text{H}}^2-1} \sum_{a''=1}^{d_{\text{H}}^2-1} k_{a'} k_{a''} (J)_{a',a''} = 0 , \quad (8.911)$$

i.e. the length of \bar{k} is a constant of the motion.

d) By using the relations [see Eq. (2.134)]

$$k'_b = \text{Tr}(\rho'\lambda_b) = \text{Tr}(U\rho U^\dagger\lambda_b) = \text{Tr}(U^\dagger\lambda_b U\rho) , \quad (8.912)$$

and [see Eq. (8.181)]

$$U^\dagger \lambda_b U = \sum_{a=1}^{d_H^2-1} \frac{\text{Tr}(U^\dagger \lambda_b U \lambda_a) \lambda_a}{2}, \quad (8.913)$$

one finds that [see Eq. (8.906)]

$$S_{ba} = \frac{\text{Tr}(\lambda'_b \lambda_a)}{2}, \quad (8.914)$$

where

$$\lambda'_b = U^\dagger \lambda_b U. \quad (8.915)$$

The following holds [see Eq. (2.134), and note that for square matrices a and b , $\text{Tr}(ab) = \sum_{n',n''} a_{n',n''} b_{n'',n'}$]

$$\begin{aligned} \sum_{a'=1}^{d_H^2-1} S_{a'b'} S_{a'b''} &= \sum_{a'=1}^{d_H^2-1} \frac{\text{Tr}(\lambda_{b'} \lambda'_{a'})}{2} \frac{\text{Tr}(\lambda'_{a'} \lambda_{b''})}{2} \\ &= \sum_{a'=1}^{d_H^2-1} \frac{\sum_{n',n''} (\lambda_{b'})_{n',n''} (\lambda'_{a'})_{n'',n'} \sum_{n''',n''''} (\lambda'_{a'})_{n''',n''''} (\lambda_{b''})_{n''',n''''}}{2} \\ &= \sum_{n',n'',n''',n''''} \frac{(\lambda_{b'})_{n',n''} (\lambda_{b''})_{n''',n''''}}{4} \sum_{a'=1}^{d_H^2-1} (\lambda'_{a'})_{n'',n'} (\lambda'_{a'})_{n''',n''''}, \end{aligned} \quad (8.916)$$

thus [see the completeness relation (8.182)]

$$\begin{aligned} \sum_{a'=1}^{d_H^2-1} S_{a'b'} S_{a'b''} &= \sum_{n',n'',n''',n''''} \frac{(\lambda_{b'})_{n',n''} (\lambda_{b''})_{n''',n''''}}{2} \left(\delta_{n'',n''''} \delta_{n',n'''} - \frac{\delta_{n'',n'} \delta_{n''',n''''}}{d_H} \right) \\ &= \frac{\sum_{n',n''} (\lambda_{b'})_{n',n''} (\lambda_{b''})_{n'',n'}}{2} - \frac{\left(\sum_{n'} (\lambda_{b'})_{n',n'} \right) \left(\sum_{n'} (\lambda_{b''})_{n',n'} \right)}{2d_H} \\ &= \frac{\text{Tr}(\lambda_{b'} \lambda_{b''})}{2} - \frac{\text{Tr}(\lambda_{b'}) \text{Tr}(\lambda_{b''})}{2d_H}, \end{aligned} \quad (8.917)$$

and thus Eq. (8.186) holds [see Eq. (8.181)]. In a similar way Eq. (8.187) can be verified.

9. Time Independent Perturbation Theory

Consider a Hamiltonian \mathcal{H}_0 having a set of eigenenergies $\{E_k\}$. Let g_k be the degree of degeneracy of eigenenergy E_k , namely g_k is the dimension of the corresponding eigensubspace, which is denoted by \mathcal{F}_k . The set $\{|k, i\rangle\}$ of eigenvectors of \mathcal{H}_0 is assumed to form an orthonormal basis for the vector space, namely

$$\mathcal{H}_0 |k, i\rangle = E_k |k, i\rangle, \quad (9.1)$$

and

$$\langle k', i' | k, i\rangle = \delta_{kk'} \delta_{ii'}. \quad (9.2)$$

For a given k the degeneracy index i can take the values $1, 2, \dots, g_k$. The set of vectors $\{|k, 1\rangle, |k, 2\rangle, \dots, |k, g_k\rangle\}$ forms an orthonormal basis for the eigensubspace \mathcal{F}_k . The closure relation can be written as

$$1 = \sum_k \sum_{i=1}^{g_k} |k, i\rangle \langle k, i| = \sum_k P_k, \quad (9.3)$$

where

$$P_k = \sum_{i=1}^{g_k} |k, i\rangle \langle k, i| \quad (9.4)$$

is a projector onto eigen subspace \mathcal{F}_k . The orthogonality condition (9.2) implies that

$$P_k P_{k'} = P_k \delta_{kk'}. \quad (9.5)$$

A perturbation $V = \lambda \tilde{V}$ is being added to the Hamiltonian

$$\mathcal{H} = \mathcal{H}_0 + \lambda \tilde{V}, \quad (9.6)$$

where $\lambda \in \mathcal{R}$. We wish to find the eigenvalues and the eigenvectors of the Hamiltonian \mathcal{H}

$$\mathcal{H} |\alpha\rangle = E |\alpha\rangle. \quad (9.7)$$

In many cases finding an analytical solution to the above equation is either very hard or impossible. In such cases one possibility is to employ numerical methods. However, another possibility arises provided that the eigenvalues and eigenvectors of \mathcal{H}_0 are known and provided that the perturbation $\lambda\tilde{V}$ can be considered as small, namely, provided the eigenvalues and eigenvectors of \mathcal{H} do not significantly differ from those of \mathcal{H}_0 . In such a case an approximate solution can be obtained by the time independent perturbation theory.

9.1 The Level E_n

Consider the level E_n of the unperturbed Hamiltonian \mathcal{H}_0 . Let P_n be the projector onto the eigensubspace \mathcal{F}_n , and let

$$Q_n = 1 - P_n = \sum_{k \neq n} P_k . \quad (9.8)$$

Equation (9.7) reads

$$\lambda\tilde{V}|\alpha\rangle = (E - \mathcal{H}_0)|\alpha\rangle . \quad (9.9)$$

It is useful to introduce the operator R , which is defined as

$$R = \sum_{k \neq n} \frac{P_k}{E - E_k} . \quad (9.10)$$

Claim. The eigenvector $|\alpha\rangle$ of the Hamiltonian \mathcal{H} is given by

$$|\alpha\rangle = \left(1 - \lambda R\tilde{V}\right)^{-1} P_n |\alpha\rangle . \quad (9.11)$$

Proof. Using Eq. (9.5) it is easy to show that

$$P_n R = R P_n = 0 . \quad (9.12)$$

Moreover, the following holds

$$Q_n R = \sum_{k \neq n} \sum_{k' \neq n} \frac{P_k P_{k'}}{E - E_{k'}} = \sum_{k \neq n} \frac{P_k}{E - E_k} = R , \quad (9.13)$$

and similarly

$$R Q_n = R . \quad (9.14)$$

Furthermore, by expressing \mathcal{H}_0 as

$$\mathcal{H}_0 = \sum_k \sum_{i=1}^{g_k} E_k |k, i\rangle \langle k, i| = E_n P_n + \sum_{k \neq n} E_k P_k , \quad (9.15)$$

one finds that

$$\begin{aligned}
 R(E - \mathcal{H}_0) &= \sum_{k \neq n} \frac{P_k \left(E - E_n P_n - \sum_{k' \neq n} E_{k'} P_{k'} \right)}{E - E_k} \\
 &= \sum_{k \neq n} \frac{P_k (E - E_k)}{E - E_k} \\
 &= Q_n ,
 \end{aligned} \tag{9.16}$$

and similarly

$$(E - \mathcal{H}_0) R = Q_n . \tag{9.17}$$

The last two results suggest that the operator R can be considered as the inverse of $E - \mathcal{H}_0$ in the subspace of eigenvalue zero of the projector P_n (which is the subspace of eigenvalue unity of the projector Q_n). Multiplying Eq. (9.9) from the left by R yields

$$\lambda R \tilde{V} |\alpha\rangle = R(E - \mathcal{H}_0) |\alpha\rangle . \tag{9.18}$$

With the help of Eq. (9.16) one finds that

$$\lambda R \tilde{V} |\alpha\rangle = Q_n |\alpha\rangle . \tag{9.19}$$

Since $P_n = 1 - Q_n$ [see Eq. (9.8)] the last result implies that

$$P_n |\alpha\rangle = |\alpha\rangle - \lambda R \tilde{V} |\alpha\rangle = \left(1 - \lambda R \tilde{V} \right) |\alpha\rangle , \tag{9.20}$$

which leads to Eq. (9.11)

$$|\alpha\rangle = \left(1 - \lambda R \tilde{V} \right)^{-1} P_n |\alpha\rangle . \tag{9.21}$$

Note that Eq. (9.11) can be expanded as power series in λ

$$|\alpha\rangle = \left(1 + \lambda R \tilde{V} + \lambda^2 R \tilde{V} R \tilde{V} + \dots \right) P_n |\alpha\rangle . \tag{9.22}$$

9.1.1 Nondegenerate Case

In this case $g_n = 1$ and

$$P_n = |n\rangle \langle n| . \tag{9.23}$$

In general the eigenvector $|\alpha\rangle$ is determined up to multiplication by a constant. For simplicity we choose that constant to be such that

$$P_n |\alpha\rangle = |n\rangle, \quad (9.24)$$

namely

$$\langle n | \alpha \rangle = 1. \quad (9.25)$$

Multiplying Eq. (9.9), which is given by

$$\lambda \tilde{V} |\alpha\rangle = (E - \mathcal{H}_0) |\alpha\rangle, \quad (9.26)$$

from the left by $\langle n |$ yields

$$\langle n | \lambda \tilde{V} |\alpha\rangle = \langle n | (E - \mathcal{H}_0) |\alpha\rangle, \quad (9.27)$$

or

$$\langle n | E |\alpha\rangle = \langle n | \mathcal{H}_0 |\alpha\rangle + \langle n | \lambda \tilde{V} |\alpha\rangle, \quad (9.28)$$

thus

$$E = E_n + \langle n | \lambda \tilde{V} |\alpha\rangle. \quad (9.29)$$

Equation (9.22) together with Eq. (9.24) yield

$$\begin{aligned} |\alpha\rangle &= \left(1 + \lambda R \tilde{V} + \lambda^2 R \tilde{V} R \tilde{V} + \dots\right) |n\rangle \\ &= |n\rangle + \lambda \sum_{\substack{k \neq n \\ i}} \frac{|k, i\rangle \langle k, i | \tilde{V} |n\rangle}{E - E_k} \\ &\quad + \lambda^2 \sum_{\substack{k \neq n \\ i}} \sum_{\substack{k' \neq n \\ i}} \frac{|k, i\rangle \langle k, i | \tilde{V} |k', i\rangle \langle k', i | \tilde{V} |n\rangle}{(E - E_k)(E - E_{k'})} \\ &\quad + \dots \end{aligned} \quad (9.30)$$

Substituting Eq. (9.30) into Eq. (9.29) yields

$$\begin{aligned} E &= E_n + \lambda \langle n | \tilde{V} |n\rangle \\ &\quad + \lambda^2 \sum_{\substack{k \neq n \\ i}} \frac{\langle n | \tilde{V} |k, i\rangle \langle k, i | \tilde{V} |n\rangle}{E - E_k} \\ &\quad + \lambda^3 \sum_{\substack{k \neq n \\ i}} \sum_{\substack{k' \neq n \\ i}} \frac{\langle n | \tilde{V} |k, i\rangle \langle k, i | \tilde{V} |k', i\rangle \langle k', i | \tilde{V} |n\rangle}{(E - E_k)(E - E_{k'})} \\ &\quad + \dots \end{aligned} \quad (9.31)$$

Note that the right hand side of Eq. (9.31) contains terms that depend on E . To second order in λ one finds

$$E = E_n + \langle n | V | n \rangle + \sum_{\substack{k \neq n \\ i}} \frac{|\langle k, i | V | n \rangle|^2}{E_n - E_k} + O(\lambda^3) . \quad (9.32)$$

Furthermore, to first order in λ Eq. (9.30) yields

$$|\alpha\rangle = |n\rangle + \sum_{\substack{k \neq n \\ i}} \frac{|k, i\rangle \langle k, i | V | n \rangle}{E_n - E_k} + O(\lambda^2) . \quad (9.33)$$

9.1.2 Degenerate Case

The set of vectors $\{|n, 1\rangle, |n, 2\rangle, \dots, |n, g_n\rangle\}$ forms an orthonormal basis for the eigensubspace \mathcal{F}_n . Multiplying Eq. (9.9) from the left by P_n yields

$$P_n \lambda \tilde{V} |\alpha\rangle = P_n (E - \mathcal{H}_0) |\alpha\rangle , \quad (9.34)$$

thus with the help of Eq. (9.15) one has

$$P_n \lambda \tilde{V} |\alpha\rangle = (E - E_n) P_n |\alpha\rangle . \quad (9.35)$$

Substituting Eq. (9.22), which is given by

$$|\alpha\rangle = \left(P_n + \lambda R \tilde{V} P_n + \lambda^2 R \tilde{V} R \tilde{V} P_n + \dots \right) |\alpha\rangle , \quad (9.36)$$

into this and noting that $P_n^2 = P_n$ yield

$$P_n \lambda \tilde{V} P_n |\alpha\rangle + \lambda^2 P_n \tilde{V} R \tilde{V} P_n |\alpha\rangle + \dots = (E - E_n) P_n |\alpha\rangle . \quad (9.37)$$

Thus, to first order in λ the energy correction $E - E_n$ is found by solving

$$P_n V P_n |\alpha\rangle = (E - E_n) P_n |\alpha\rangle . \quad (9.38)$$

The solutions are the eigenvalues of the $g_n \times g_n$ matrix representation of the operator V in the subspace \mathcal{F}_n .

For some cases, the Schrieffer-Wolff transformation [see Eq. (9.107)] provides an alternative method for the calculation of the perturbation expansion. Especially, for the degenerate case, this transformation can be used to calculate energy corrections to second order in λ [while Eq. (9.38) is limited to first order only].

9.2 Example

Consider a point particle having mass m whose Hamiltonian is given by

$$\mathcal{H} = \mathcal{H}_0 + V, \quad (9.39)$$

where

$$\mathcal{H}_0 = \frac{p^2}{2m} + \frac{m\omega^2 x^2}{2}. \quad (9.40)$$

and where

$$V = \lambda \hbar \omega \sqrt{\frac{m\omega}{\hbar}} x. \quad (9.41)$$

The eigenvectors and eigenvalues of the Hamiltonian \mathcal{H}_0 , which describes a one-dimensional harmonic oscillator, are given by

$$\mathcal{H}_0 |n\rangle = E_n |n\rangle, \quad (9.42)$$

where $n = 0, 1, 2, \dots$, and where

$$E_n(\lambda = 0) = \hbar \omega \left(n + \frac{1}{2} \right). \quad (9.43)$$

Note that, as was shown in chapter 5 [see Eq. (5.179)], the eigenvectors and eigenvalues of \mathcal{H} can be found analytically for this particular case. For the sake of comparison we first derive this exact solution. Writing \mathcal{H} as

$$\begin{aligned} \mathcal{H} &= \frac{p^2}{2m} + \frac{m\omega^2 x^2}{2} + \lambda \hbar \omega \sqrt{\frac{m\omega}{\hbar}} x \\ &= \frac{p^2}{2m} + \frac{m\omega^2}{2} \left(x + \lambda \sqrt{\frac{\hbar}{m\omega}} \right)^2 - \frac{1}{2} \hbar \omega \lambda^2, \end{aligned} \quad (9.44)$$

one sees that \mathcal{H} describes a one-dimensional harmonic oscillator (as \mathcal{H}_0 also does). The exact eigenenergies are given by

$$E_n(\lambda) = E_n(\lambda = 0) - \frac{1}{2} \hbar \omega \lambda^2, \quad (9.45)$$

and the corresponding exact wavefunctions are

$$\langle x' | n(\lambda) \rangle = \left\langle x' + \lambda \sqrt{\frac{\hbar}{m\omega}} | n \right\rangle. \quad (9.46)$$

Using identity (3.19), which is given by

$$J(\Delta x) |x'\rangle = |x' + \Delta x\rangle , \quad (9.47)$$

where $J(\Delta x)$ is the translation operator, the exact solution (9.46) can be rewritten as

$$\langle x' | n(\lambda) \rangle = \langle x' | J \left(-\lambda \sqrt{\frac{\hbar}{m\omega}} \right) |n\rangle , \quad (9.48)$$

or simply as

$$|n(\lambda)\rangle = J \left(-\lambda \sqrt{\frac{\hbar}{m\omega}} \right) |n\rangle . \quad (9.49)$$

Next we calculate an approximate eigenvalues and eigenvectors using perturbation theory. Using the identity

$$x = \sqrt{\frac{\hbar}{2m\omega}} (a + a^\dagger) , \quad (9.50)$$

one has

$$V = \frac{\lambda\hbar\omega}{\sqrt{2}} (a + a^\dagger) . \quad (9.51)$$

Furthermore, using the identities

$$a |n\rangle = \sqrt{n} |n-1\rangle , \quad (9.52)$$

$$a^\dagger |n\rangle = \sqrt{n+1} |n+1\rangle , \quad (9.53)$$

one has

$$\begin{aligned} \langle m | V |n\rangle &= \frac{\lambda\hbar\omega}{\sqrt{2}} (\langle m | a |n\rangle + \langle m | a^\dagger |n\rangle) \\ &= \frac{\lambda\hbar\omega}{\sqrt{2}} (\sqrt{n}\delta_{m,n-1} + \sqrt{n+1}\delta_{m,n+1}) . \end{aligned} \quad (9.54)$$

Thus $E_n(\lambda)$ can be expanded using Eq. (9.32) as

$$\begin{aligned} E_n(\lambda) &= E_n + \underbrace{\langle n | V |n\rangle}_{=0} + \sum_{\substack{k \neq n \\ i}} \frac{|\langle k, i | V |n\rangle|^2}{E_n - E_k} + O(\lambda^3) \\ &= E_n + \frac{|\langle n-1 | V |n\rangle|^2}{E_n - E_{n-1}} + \frac{|\langle n+1 | V |n\rangle|^2}{E_n - E_{n+1}} + O(\lambda^3) \\ &= \hbar\omega \left(n + \frac{1}{2} \right) + \hbar\omega \frac{n\lambda^2}{2} - \hbar\omega \frac{(n+1)\lambda^2}{2} + O(\lambda^3) \\ &= \hbar\omega \left(n + \frac{1}{2} \right) - \hbar\omega \frac{\lambda^2}{2} + O(\lambda^3) , \end{aligned} \quad (9.55)$$

in agreement (to second order) with the exact result (9.45), and $|n(\lambda)\rangle$ can be expanded using Eq. (9.30) as

$$\begin{aligned}
 |n(\lambda)\rangle &= |n\rangle + \sum_{\substack{k \neq n \\ i}} \frac{|k, i\rangle \langle k, i| V |n\rangle}{E_n - E_k} + O(\lambda^2) \\
 &= |n\rangle + \frac{|n-1\rangle \langle n-1| V |n\rangle}{E_n - E_{n-1}} + \frac{|n+1\rangle \langle n+1| V |n\rangle}{E_n - E_{n+1}} + O(\lambda^2) \\
 &= |n\rangle + \frac{|n-1\rangle \frac{\lambda \hbar \omega}{\sqrt{2}} \sqrt{n}}{\hbar \omega} - \frac{|n+1\rangle \frac{\lambda \hbar \omega}{\sqrt{2}} \sqrt{n+1}}{\hbar \omega} + O(\lambda^2) \\
 &= |n\rangle + \frac{\lambda}{\sqrt{2}} a |n\rangle - \frac{\lambda}{\sqrt{2}} a^\dagger |n\rangle + O(\lambda^2) .
 \end{aligned} \tag{9.56}$$

Note that with the help of the following identify

$$p = i \sqrt{\frac{m \hbar \omega}{2}} (-a + a^\dagger) , \tag{9.57}$$

the last result can be written as

$$|n(\lambda)\rangle = \left(1 + \lambda \sqrt{\frac{\hbar}{m \omega}} \frac{ip}{\hbar} \right) |n\rangle + O(\lambda^2) . \tag{9.58}$$

Alternatively, in terms of the translation operator $J(\Delta x)$, which is given by

$$J(\Delta x) = \exp\left(-\frac{ip \Delta x}{\hbar}\right) , \tag{9.59}$$

one has

$$|n(\lambda)\rangle = J\left(-\lambda \sqrt{\frac{\hbar}{m \omega}}\right) |n\rangle + O(\lambda^2) , \tag{9.60}$$

in agreement (to second order) with the exact result (9.49).

9.3 Problems

1. **The volume effect:** The energy spectrum of the hydrogen atom was calculated in chapter 8 by considering the proton to be a point particle. Consider a model in which the proton is instead assumed to be a sphere of radius ρ_0 where $\rho_0 \ll a_0$ (a_0 is Bohr's radius), and the charge of the proton $+e$ is assumed to be uniformly distributed in that sphere. Show that the energy shift due to such perturbation to lowest order in perturbation theory is given by

$$\Delta E_{n,l} = \frac{e^2}{10} \rho_0^2 |R_{n,l}(0)|^2, \quad (9.61)$$

where $R_{n,l}(r)$ is the radial wave function.

2. Consider an hydrogen atom. A perturbation given by

$$V(r) = -\lambda \frac{e^2}{r} \left(e^{-\frac{r}{a}} - 1 \right), \quad (9.62)$$

is added, where e the electron charge, a is positive, and $r = \sqrt{x^2 + y^2 + z^2}$ is the radial coordinate. Calculate to first order in the real parameter λ the energy of the ground state E_1 .

3. The energy of a relativistic particle having mass m and momentum p is given by $E(p) = \sqrt{m^2 c^4 + p^2 c^2}$. The kinetic energy thus can be expanded in powers of p as

$$E(p) - E(0) = \frac{p^2}{2m} - \frac{p^4}{8m^3 c^2} + O(p^6).$$

Consider a particle having mass m in a harmonic oscillator potential well given by $V(x) = (1/2) m \omega^2 x^2$. Calculate to lowest nonvanishing order the correction to the ground state energy due to the relativistic correction $-p^4/8m^3 c^2$ to the kinetic energy.

4. Consider a particle having mass m in a 3D central potential given by

$$V(r) = \frac{m\omega^2 r^2}{2} + gr^4. \quad (9.63)$$

where $r = \sqrt{x^2 + y^2 + z^2}$ is the radial coordinate, and where ω and g are both positive. Calculate to lowest nonvanishing order in g the energy of the ground state.

5. Consider a hydrogen atom. A perturbation given by

$$V = Ar, \quad (9.64)$$

where $r = \sqrt{x^2 + y^2 + z^2}$ is the radial coordinate and A is a constant is added.

- a) Calculate to first order in A the energy of the ground state.
 - b) Calculate to first order in A the energy of the first excited state.
6. A weak uniform electric field $\mathbf{E} = E\hat{z}$, where E is a constant, is applied to a hydrogen atom. Calculate to 1st order in perturbation theory the correction to the energy of the
- a) level $n = 1$ (n is the principle quantum number).
 - b) level $n = 2$.
7. A particle having mass m and charge q is confined in a 3D infinite potential well of width l , which is given by

$$V(x, y, z) = \begin{cases} 0 & \text{if } |x| \leq l/2 \text{ and } |y| \leq l/2 \text{ and } |z| \leq l/2 \\ +\infty & \text{elsewhere} \end{cases} . \quad (9.65)$$

A weak uniform electric field $\mathbf{E} = E\hat{\mathbf{z}}$, where E is a constant, is applied. Calculate the eigenenergies to first order in E .

8. Consider two particles, both having the same mass m , moving in a one-dimensional potential with coordinates x_1 and x_2 respectively. The potential energy is given by

$$V(x_1, x_2) = \frac{1}{2}m\omega^2(x_1 - a)^2 + \frac{1}{2}m\omega^2(x_2 + a)^2 + \lambda m\omega^2(x_1 - x_2)^2 , \quad (9.66)$$

where λ is real. Find the energy of the ground state to lowest non-vanishing order in λ .

9. A particle having mass m is confined in a potential well of width l , which is given by

$$V(x) = \begin{cases} 0 & \text{for } 0 \leq x \leq l \\ +\infty & \text{elsewhere} \end{cases} . \quad (9.67)$$

Find to lowest order in perturbation theory the correction to the ground state energy due to a perturbation given by

$$W(x) = w_0\delta\left(x - \frac{l}{2}\right) , \quad (9.68)$$

where w_0 is a real constant.

10. Consider a particle having mass m in a two-dimensional potential well of width a that is given by

$$V(x, y) = \begin{cases} 0 & \text{if } 0 \leq x \leq a \text{ and } 0 \leq y \leq a \\ +\infty & \text{elsewhere} \end{cases} . \quad (9.69)$$

A perturbation given by

$$W(x, y) = \begin{cases} w_0 & \text{if } 0 \leq x \leq \frac{a}{2} \text{ and } 0 \leq y \leq \frac{a}{2} \\ 0 & \text{elsewhere} \end{cases} , \quad (9.70)$$

is added.

- a) Calculate to lowest non-vanishing order in w_0 the energy of the ground state.
 b) The same for the first excited state.
11. Consider a particle having mass m moving in a potential energy given by

$$V(x, y) = \frac{m\omega^2}{2}(x^2 + y^2) + \beta m\omega^2 xy , \quad (9.71)$$

where the angular frequency ω is a constant and where the dimensionless real constant β is assumed to be small.

- a) Calculate to first order in β the energy of the ground state.
 b) Calculate to first order in β the energy of the first excited state.
12. Consider a harmonic oscillator having angular resonance frequency ω_0 . A perturbation given by

$$V = \frac{\hbar\omega_1}{2} (a^\dagger a^\dagger + aa) \quad (9.72)$$

is added, where a is the annihilation operator and ω_1 is a positive constant. Calculate the energies of the system to second order in ω_1 .

13. The Hamiltonian of a spin $S = 1$ is given by

$$\mathcal{H} = \alpha S_z^2 + \beta (S_x^2 - S_y^2) , \quad (9.73)$$

where α and β are both constants.

- a) Write the matrix representation of \mathcal{H} in the basis

$$\{|s = 1, m = -1\rangle, |s = 1, m = 0\rangle, |s = 1, m = 1\rangle\} .$$

- b) Calculate (exactly) the eigenenergies and the corresponding eigenvectors.
 c) For the case $\beta \ll \alpha$ use perturbation theory to calculate to lowest order in α and β the eigenenergies of the system.
14. **nitrogen-vacancy defect in diamond** - The orbital ground state of a nitrogen-vacancy (NV) defect in diamond is a spin triplet. In the presence of externally applied magnetic field \mathbf{B} the Hamiltonian \mathcal{H} is given by

$$\frac{\mathcal{H}}{\hbar} = \frac{DS_z^2}{\hbar^2} + E \frac{S_+^2 + S_-^2}{2\hbar^2} - \frac{\gamma \mathbf{B} \cdot \mathbf{S}}{\hbar} , \quad (9.74)$$

where $\mathbf{S} = S_x \hat{\mathbf{x}} + S_y \hat{\mathbf{y}} + S_z \hat{\mathbf{z}}$ is the vector spin $S = 1$ operator, the operator S_\pm is given by $S_\pm = S_x \pm iS_y$ [see Eqs. (6.32) and (6.36)], $D/2\pi = 2870$ MHz, $E/2\pi \simeq 1$ MHz (exact value depends on strain in the diamond lattice) and the spin gyromagnetic ratio is given by $\gamma = 2\mu_B/\hbar = 28.03 \times 2\pi$ GHz T⁻¹ [see Eq. (2.91)]. Note that it is assumed that the $\hat{\mathbf{z}}$ direction is parallel to the NV axis. Calculate the eigenvalues ϵ_n , where $n \in \{1, 2, 3\}$, of \mathcal{H} using perturbation theory to lowest non-vanishing order in the applied magnetic field. Assumed that $E \ll D$.

15. **nitrogen substitution defect in diamond** - A nitrogen 14 (nuclear spin 1) substitution defect (P1) in diamond has four locally stable configurations. In each configuration a so-called static Jahn-Teller distortion occurs, and an unpaired electron (having spin 1/2) is shared by the nitrogen atom and by one of the four neighboring carbon atoms. The spin Hamiltonian of a P1 defect is given by

$$\mathcal{H} = \mathcal{H}_e + \mathcal{H}_n + \mathcal{H}_{en} , \quad (9.75)$$

where $\mathcal{H}_e = \gamma_e B S_z$ is the electronic spin Hamiltonian, $\gamma_e = 2\pi \times 28.03 \text{ GHz T}^{-1}$ is the electron spin gyromagnetic ratio [see Eq. (2.91)], B is an externally applied magnetic field, which is assumed to point in the z direction, \mathcal{H}_n , which is given by $\mathcal{H}_n = \hbar^{-1} Q I_z^2 + \gamma_n B I_z$, is the nitrogen 14 nuclear spin Hamiltonian, $Q = -2\pi \times 3.97 \text{ MHz}$ is the quadrupole coupling, $\gamma_n = 2\pi \times 3.0766 \text{ MHz T}^{-1}$ is the nuclear gyromagnetic ratio, and \mathcal{H}_{en} , which is given by

$$\mathcal{H}_{en} = \hbar^{-1} \mathbf{S} R_{\hat{\mathbf{n}}_B}^{-1} \mathcal{A} R_{\hat{\mathbf{n}}_B} \mathbf{I}^T, \quad (9.76)$$

is the electron-nuclear coupling Hamiltonian. The matrix $R_{\hat{\mathbf{n}}_B}$ is a rotation matrix that satisfies $R_{\hat{\mathbf{n}}_B} \hat{\mathbf{n}}_B = \hat{\mathbf{z}}$, the unit vector

$$\hat{\mathbf{n}}_B = (\sin \theta_B \cos \varphi_B, \sin \theta_B \sin \varphi_B, \cos \theta_B) \quad (9.77)$$

is parallel to the P1 symmetry axis (connecting the nitrogen atom and one of the neighboring carbon atoms, near which the electron is localized), the matrix \mathcal{A} is given by

$$\mathcal{A} = \begin{pmatrix} A_{\perp} & 0 & 0 \\ 0 & A_{\perp} & 0 \\ 0 & 0 & A_{\parallel} \end{pmatrix}, \quad (9.78)$$

where $A_{\parallel} = 2\pi \times 114 \text{ MHz}$ and $A_{\perp} = 2\pi \times 81.3 \text{ MHz}$ are respectively the longitudinal and transverse hyperfine coupling parameters, $\mathbf{S} = S_x \hat{\mathbf{x}} + S_y \hat{\mathbf{y}} + S_z \hat{\mathbf{z}}$ is an electronic spin 1/2 vector operator, and $\mathbf{I} = I_x \hat{\mathbf{x}} + I_y \hat{\mathbf{y}} + I_z \hat{\mathbf{z}}$ is a nuclear spin 1 vector operator. Consider the case where the nitrogen 14 nuclear Hamiltonian \mathcal{H}_n and the coupling Hamiltonian \mathcal{H}_{en} are treated as perturbations and the Zeeman term $\gamma_n \mathbf{B} \cdot \mathbf{I}$ is disregarded. Calculate the eigenvalues ϵ_n , where $n \in \{1, 2, \dots, 6\}$, of \mathcal{H} in the limit of high applied magnetic field B .

16. **Jaynes-Cummings model** - Consider a system composed of a harmonic oscillator having angular resonance frequency $\omega_r > 0$ and a two-level system. The Hamiltonian of the system is assumed to be given by

$$\mathcal{H} = \mathcal{H}_r + \mathcal{H}_a + V. \quad (9.79)$$

The term \mathcal{H}_r is the Hamiltonian for the harmonic oscillator [see Eq. (5.16)]

$$\mathcal{H}_r = \hbar \omega_r \left(a^\dagger a + \frac{1}{2} \right), \quad (9.80)$$

where a and a^\dagger are annihilation and creation operators respectively. The term \mathcal{H}_a is the Hamiltonian for the two-level system

$$\mathcal{H}_a = \frac{\hbar \omega_a}{2} \Sigma_z, \quad (9.81)$$

where

$$\Sigma_z = |+\rangle\langle+| - |-\rangle\langle-| ,$$

the ket vectors $|\pm\rangle$ represent the two levels and where $\omega_a > 0$. The coupling term between the oscillator and the two-level system is given by

$$V = \hbar g (a^\dagger \Sigma_- + a \Sigma_+) , \quad (9.82)$$

where

$$\Sigma_+ = |+\rangle\langle-| , \quad (9.83)$$

$$\Sigma_- = |-\rangle\langle+| . \quad (9.84)$$

- a) Calculate to lowest non-vanishing order in g the eigenenergies of the system for the case $\omega_r \neq \omega_a$.
- b) The same for the case $\omega_r = \omega_a$.
- c) Consider the unitary transformation

$$\mathcal{H}' = U^\dagger \mathcal{H} U , \quad (9.85)$$

where

$$U = \exp\left(\frac{g}{\Delta} \mathcal{S}\right) , \quad (9.86)$$

the operator \mathcal{S} is given by

$$\mathcal{S} = (a^\dagger \Sigma_- - a \Sigma_+) , \quad (9.87)$$

and where

$$\Delta = \omega_a - \omega_r . \quad (9.88)$$

Calculate \mathcal{H}' to second order in g/Δ .

- d) Find the exact energy eigenvectors and eigenenergies of \mathcal{H} .
 - e) Find a unitary operator U that diagonalizes \mathcal{H} .
 - f) Use the result of the previous exercise and calculate $\mathcal{H}' = U \mathcal{H} U^\dagger$ to fourth order in g/Δ .
17. Consider a particle having mass m in a two-dimensional potential given by

$$V_0 = \frac{1}{2} m \omega^2 (x^2 + y^2) . \quad (9.89)$$

The following perturbation is added

$$V_1 = \frac{\beta \omega}{\hbar} L_z^2 , \quad (9.90)$$

where L_z is the z component of the angular momentum operator.

- a) Find to second orders in β the energy of the ground state.
 b) Find to first order in β the energy of the first excited level.
 18. A particle having mass m moves in a one-dimensional potential

$$V(x) = \begin{cases} V_0 \sin \frac{2\pi x}{l} & 0 \leq x \leq l \\ \infty & \text{else} \end{cases} . \quad (9.91)$$

Consider the constant V_0 to be small. Calculate the system's eigenenergies E_n to first order in V_0 .

19. Consider a particle having mass m confined by the one-dimensional potential well, which is given by

$$V(x) = \begin{cases} \infty & x < 0 \\ \frac{\epsilon x}{L} & 0 \leq x \leq L \\ \infty & x > L \end{cases} .$$

Find to first order in ϵ the energy of the ground state.

20. A particle of mass m is trapped in an infinite 2 dimensional well of width l

$$V(x, y) = \begin{cases} 0 & 0 \leq x \leq l \text{ and } 0 \leq y \leq l \\ \infty & \text{else} \end{cases} . \quad (9.92)$$

A perturbation given by

$$W(x, y) = \lambda \frac{\hbar^2 \pi^2}{m} \delta(x - l_x) \delta(y - l_y) . \quad (9.93)$$

is added, where

$$0 \leq l_x \leq l , \quad (9.94)$$

and

$$0 \leq l_y \leq l . \quad (9.95)$$

Calculate to 1st order in perturbation theory the correction to the energy of the:

- a) ground state.
 b) first excited state.
 21. Consider a rigid rotator whose Hamiltonian is given by

$$\mathcal{H} = \frac{L_x^2 + L_y^2}{2I_{xy}} + \frac{L_z^2}{2I_z} + \lambda \frac{L_x^2 - L_y^2}{2I_{xy}} , \quad (9.96)$$

where \mathbf{L} is the angular momentum vector operator. Use perturbation theory to calculate the energy of the ground state to second order in λ .

22. Consider two particles having the same mass m moving along the x axis. The Hamiltonian of the system is given by

$$\mathcal{H} = \frac{p_1^2}{2m} + \frac{p_2^2}{2m} - \alpha\delta(x_1) - \alpha\delta(x_2) + \lambda\delta(x_1 - x_2) , \quad (9.97)$$

where x_1 and x_2 are the coordinates of the first and second particle respectively, p_1 and p_2 are the corresponding canonically conjugate momentums, α and λ are both real positive constants and $\delta()$ denotes the delta function. Calculate to first order in λ the energy of the ground state of the system.

23. In this problem the main results of time independent perturbation theory are derived using an alternative approach. Consider a general square matrix

$$W = D + \Omega V , \quad (9.98)$$

where $\Omega \in \mathcal{R}$, D is diagonal

$$D |n_0\rangle = \lambda_{n_0} |n_0\rangle , \quad (9.99a)$$

$$\langle n_0| D = \lambda_{n_0} \langle n_0| , \quad (9.99b)$$

and we assume that none of the eigenvalues of D is degenerate. The set of eigenvectors of D is assumed to be orthonormal

$$\langle n_0|m_0\rangle = \delta_{nm} , \quad (9.100)$$

and complete (the dimensionality is assumed to be finite)

$$1 = \sum_n |n_0\rangle \langle n_0| . \quad (9.101)$$

Calculate the eigenvalues of W

$$W |n\rangle = \lambda |n\rangle \quad (9.102)$$

to second order in Ω .

24. **Schrieffer-Wolff transformation** - Consider the Hamiltonian \mathcal{H} , which is given by

$$\mathcal{H} = \mathcal{H}_0 + \lambda \tilde{V} , \quad (9.103)$$

where $\lambda \in \mathcal{R}$. The set $\{|k\rangle\}$ of eigenvectors of \mathcal{H}_0 with corresponding eigenvalues $\{E_k\}$, which satisfy

$$\mathcal{H}_0 |k\rangle = E_k |k\rangle , \quad (9.104)$$

is assumed to form an orthonormal basis for the vector space, i.e.

$$\langle k' | k \rangle = \delta_{k,k'} . \quad (9.105)$$

Consider the transformation

$$\mathcal{H}_R = e^L \mathcal{H} e^{-L} , \quad (9.106)$$

where the operator L is assumed to be anti Hermitian, i.e. $L^\dagger = -L$, in order to ensure that e^L is unitary.

- a) Show that to second order in λ the matrix elements $\langle k | \mathcal{H}_R | k' \rangle$ are given by

$$\langle k | \mathcal{H}_R | k' \rangle = E_k \delta_{k,k'} + \frac{\lambda^2}{2} \sum_{k''} \langle k | \tilde{V} | k'' \rangle \langle k'' | \tilde{V} | k' \rangle \left(\frac{1}{E_k - E_{k''}} - \frac{1}{E_{k''} - E_{k'}} \right) , \quad (9.107)$$

provided that the following condition is satisfied

$$\lambda \tilde{V} + [L, \mathcal{H}_0] = 0 . \quad (9.108)$$

Note that to first order in λ the following holds $\langle k | \mathcal{H}_R | k'' \rangle = \langle k | \mathcal{H}_0 | k'' \rangle$, thus, in spite of the fact that the perturbation $\lambda \tilde{V}$ is first order in λ , the transformed Hamiltonian \mathcal{H}_R depends on λ only to second order.

- b) **adiabatic elimination** - Consider a system composed of two subsystems labelled as slow (S) and fast (F). The Hamiltonian is expressed as [compare with Eq. (9.103)]

$$\mathcal{H} = \mathcal{H}_S + \mathcal{H}_F + \lambda \tilde{V} , \quad (9.109)$$

and the following holds [compare with Eq. (9.104)]

$$\mathcal{H}_S |k_S k_F\rangle = E_{k_S} |k_S k_F\rangle , \quad (9.110)$$

$$\mathcal{H}_F |k_S k_F\rangle = E_{k_F} |k_S k_F\rangle , \quad (9.111)$$

and [compare with Eq. (9.105)]

$$\langle k_S'' k_F'' | k_S' k_F' \rangle = \delta_{k_S', k_S''} \delta_{k_F', k_F''} , \quad (9.112)$$

$$\sum_{k_S, k_F} |k_S k_F\rangle \langle k_S k_F| = 1 . \quad (9.113)$$

It is assumed that spacing between the eigen energies E_{k_F} of the fast subsystem is much larger than spacing between the eigen energies E_{k_S} of the slow subsystem. To second order in λ , find an effective Hamiltonian $\mathcal{H}_{R, \text{eff}}^{(k_F)}$ for the slow subsystem, corresponding to the case where the fast subsystem occupies the state $|k_F\rangle$.

25. Consider a Hamiltonian having matrix representation given by

$$H = H_0 + \lambda \tilde{V} , \quad (9.114)$$

where

$$H_0 = \begin{pmatrix} 0 & 0 & 0 & 0 \\ 0 & 2E & 0 & 0 \\ 0 & 0 & 2E & 0 \\ 0 & 0 & 0 & 2E \end{pmatrix}, \quad (9.115)$$

λ is real, and

$$\tilde{V} = \begin{pmatrix} 0 & \alpha & \beta & \gamma \\ \alpha^* & 0 & 0 & 0 \\ \beta^* & 0 & 0 & 0 \\ \gamma^* & 0 & 0 & 0 \end{pmatrix}. \quad (9.116)$$

Calculate the energy eigenvalues of H to lowest non-vanishing order in λ .

26. Calculate the expectation values of the kinetic energy $\langle nlm|T|nlm\rangle$ and the potential energy $\langle nlm|V|nlm\rangle$ of a hydrogen atom in an energy eigenstate $|nlm\rangle$.
27. Calculate the expectation values $\langle nlm|r^{-2}|nlm\rangle$, where r is the radial position coordinate and where $|nlm\rangle$ is an energy eigenstate $|nlm\rangle$ of a hydrogen atom.

9.4 Solutions

1. The radial force acting on the electron is found using Gauss' theorem

$$F_r(r) = \begin{cases} \frac{e^2}{r^2} & r > \rho_0 \\ \frac{e^2}{r^2} \left(\frac{r}{\rho_0}\right)^3 & r \leq \rho_0 \end{cases}. \quad (9.117)$$

The potential energy $V(r)$ is found by integrating $F_r(r)$ and by requiring that $V(r)$ is continuous at $r = \rho_0$

$$V(r) = \begin{cases} -\frac{e^2}{r} & r > \rho_0 \\ \frac{e^2}{2\rho_0} \left(\left(\frac{r}{\rho_0}\right)^2 - 3 \right) & r \leq \rho_0 \end{cases}. \quad (9.118)$$

Thus, the perturbation term in the Hamiltonian is given by

$$V_p(r) = V(r) - \left(-\frac{e^2}{r}\right) = \begin{cases} 0 & r > \rho_0 \\ \frac{e^2}{2\rho_0} \left(\left(\frac{r}{\rho_0}\right)^2 + \frac{2\rho_0}{r} - 3 \right) & r \leq \rho_0 \end{cases}. \quad (9.119)$$

To first order one has

$$\Delta E_{n,l} = \langle nlm|V_p|nlm\rangle. \quad (9.120)$$

The wavefunctions for the unperturbed case are given by

$$\psi_{nlm}(r, \theta, \phi) = R_{nl}(r) Y_l^m(\theta, \phi) , \quad (9.121)$$

Since V_p depends on r only, one finds that

$$\begin{aligned} \Delta E_{n,l} &= \int_0^\infty dr r^2 |R_{nl}(r)|^2 V_p(r) \\ &= \int_0^{\rho_0} dr r^2 |R_{nl}(r)|^2 \frac{e^2}{2\rho_0} \left(\left(\frac{r}{\rho_0} \right)^2 + \frac{2\rho_0}{r} - 3 \right) . \end{aligned} \quad (9.122)$$

In the limit where $\rho_0 \ll a_0$ the term $|R_{nl}(r)|^2$ can approximately be replaced by $|R_{nl}(0)|^2$, thus

$$\begin{aligned} \Delta E_{n,l} &= |R_{nl}(0)|^2 \int_0^{\rho_0} dr r^2 \frac{e^2}{2\rho_0} \left(\left(\frac{r}{\rho_0} \right)^2 + \frac{2\rho_0}{r} - 3 \right) \\ &= \frac{e^2 \rho_0^2}{10} |R_{nl}(0)|^2 . \end{aligned} \quad (9.123)$$

2. The ground state energy E_1 is given by [see Eqs. (7.84), (7.89) and (6.130)]

$$E_1 = -\frac{e^2}{2a_0} + \int_0^\infty dr r^2 V(r) R_{10}^2(r) \int_{-1}^1 d(\cos \theta) \int_0^{2\pi} d\phi |Y_0^0(\theta, \phi)|^2 + O(\lambda^2) , \quad (9.124)$$

where a_0 is the Bohr's radius, $R_{10}(r) = 2a_0^{-3/2} e^{-r/a_0}$, and $Y_0^0(\theta, \phi) = \sqrt{1/(4\pi)}$, hence

$$\begin{aligned} \frac{E_1}{-\frac{e^2}{2a_0}} &= 1 + \lambda \int_0^\infty d\rho \rho^2 \frac{8e^{-2\rho} \left(e^{-\frac{a_0}{a}\rho} - 1 \right)}{\rho} + O(\lambda^2) \\ &= 1 - \lambda \frac{2\frac{a_0}{a} \left(4 + \frac{a_0}{a} \right)}{4 + 4\frac{a_0}{a} + \frac{a_0^2}{a^2}} + O(\lambda^2) . \end{aligned} \quad (9.125)$$

3. With the help of Eq. (9.31) one finds that the ground state energy is given to first order in the perturbation expansion by

$$E = \frac{\hbar\omega}{2} - \frac{1}{8m^3 c^2} \langle 0 | p^4 | 0 \rangle + O(c^{-4}) . \quad (9.126)$$

The following holds [see Eqs. (5.12), (5.28) and (5.29)]

$$p^2 |0\rangle = \frac{m\hbar\omega}{2} (a - a^\dagger) |1\rangle = \frac{m\hbar\omega}{2} (|0\rangle - \sqrt{2}|2\rangle) , \quad (9.127)$$

thus

$$E = \frac{\hbar\omega}{2} \left(1 - \frac{3\hbar\omega}{16mc^2} \right) + O(c^{-4}) . \quad (9.128)$$

4. For the unperturbed case, i.e. when $g = 0$, the energy eigenvectors are denoted by $|n_x, n_y, n_z\rangle$, where the quantum numbers n_x, n_y and n_z are non-negative integers, and the corresponding eigenenergies are given by

$$E_{n_x, n_y, n_z} = \hbar\omega \left(\frac{3}{2} + n_x + n_y + n_z \right) . \quad (9.129)$$

With the help of Eqs. (5.11), (5.13), (5.28), (5.29) and (9.31) together with the relation

$$\begin{aligned} r^4 &= (x^2 + y^2 + z^2)^2 \\ &= x^4 + y^4 + z^4 + 2x^2y^2 + 2y^2z^2 + 2z^2x^2 , \end{aligned} \quad (9.130)$$

one finds that the energy of the ground state E_{gs} is given by

$$\begin{aligned} E_{\text{gs}} &= \frac{3\hbar\omega}{2} + g \langle 0, 0, 0 | r^4 | 0, 0, 0 \rangle + O(g^2) \\ &= \frac{3\hbar\omega}{2} + 3g \langle 0, 0, 0 | x^4 | 0, 0, 0 \rangle + 6g (\langle 0, 0, 0 | x^2 | 0, 0, 0 \rangle)^2 + O(g^2) \\ &= \frac{3\hbar\omega}{2} + 15g \left(\frac{\hbar}{2m\omega} \right)^2 + O(g^2) . \end{aligned} \quad (9.131)$$

5. The wavefunctions for the unperturbed case are given by

$$\psi_{nlm}(r, \theta, \phi) = R_{nl}(r) Y_l^m(\theta, \phi) , \quad (9.132)$$

where for the states relevant to this problem

$$R_{10}(r) = 2 \left(\frac{1}{a_0} \right)^{3/2} e^{-r/a_0}, \quad (9.133a)$$

$$R_{20}(r) = (2 - r/a_0) \left(\frac{1}{2a_0} \right)^{3/2} e^{-\frac{r}{2a_0}}, \quad (9.133b)$$

$$R_{21}(r) = \left(\frac{1}{2a_0} \right)^{3/2} \frac{r}{\sqrt{3}a_0} e^{-\frac{r}{2a_0}}, \quad (9.133c)$$

$$Y_0^0(\theta, \phi) = \sqrt{\frac{1}{4\pi}}, \quad (9.133d)$$

$$Y_1^{-1}(\theta, \phi) = \frac{1}{2} \sqrt{\frac{3}{2\pi}} \sin \theta e^{-i\phi}, \quad (9.133e)$$

$$Y_1^0(\theta, \phi) = \frac{1}{2} \sqrt{\frac{3}{\pi}} \cos \theta, \quad (9.133f)$$

$$Y_1^1(\theta, \phi) = -\frac{1}{2} \sqrt{\frac{3}{2\pi}} \sin \theta e^{i\phi}, \quad (9.133g)$$

and the corresponding eigenenergies are given by

$$E_n^{(0)} = -\frac{E_I}{n^2}, \quad (9.134)$$

where

$$E_I = \frac{m_e e^4}{2\hbar^2}. \quad (9.135)$$

The perturbation term V in the Hamiltonian is given by $V = Ar$. The matrix elements of V are expressed as

$$\begin{aligned} \langle n'l'm' | V | nlm \rangle &= A \int_0^\infty dr r^3 R_{n'l'} R_{nl} \int_{-1}^1 d(\cos \theta) \int_0^{2\pi} d\phi \left(Y_{l'}^{m'} \right)^* Y_l^m \\ &= A \delta_{l,l'} \delta_{m,m'} \int_0^\infty dr r^3 R_{n'l'} R_{nl}. \end{aligned} \quad (9.136)$$

a) Thus, to first order

$$E_1 = E_1^{(0)} + \langle 100 | V | 100 \rangle + O(A^2), \quad (9.137)$$

where

$$\langle 100 | V | 100 \rangle = A \int_0^\infty dr r^3 R_{10}^2(r) = \frac{3Aa_0}{2}. \quad (9.138)$$

- b) The first excited state is degenerate, however, as can be seen from Eq. (9.136) all off-diagonal elements are zero. The diagonal elements are given by

$$\langle 200 | V | 200 \rangle = A \int_0^\infty dr r^3 R_{20}^2 = 6Aa_0 , \quad (9.139a)$$

$$\langle 21m | V | 21m \rangle = A \int_0^\infty dr r^3 R_{21}^2 = 5Aa_0 . \quad (9.139b)$$

Thus, the degeneracy is lifted

$$E_{2,l=0} = E_2^{(0)} + 6Aa_0 + O(A^2) , \quad (9.140)$$

$$E_{2,l=1} = E_2^{(0)} + 5Aa_0 + O(A^2) . \quad (9.141)$$

6. The wavefunctions for the unperturbed case are given by

$$\psi_{nlm}(r, \theta, \phi) = R_{nl}(r) Y_l^m(\theta, \phi) , \quad (9.142)$$

where for the states relevant to this problem

$$R_{10}(r) = 2 \left(\frac{1}{a_0} \right)^{3/2} e^{-r/a_0} , \quad (9.143)$$

$$R_{20}(r) = (2 - r/a_0) \left(\frac{1}{2a_0} \right)^{3/2} e^{-r/2a_0} , \quad (9.144)$$

$$R_{21}(r) = \left(\frac{1}{2a_0} \right)^{3/2} \frac{r}{\sqrt{3}a_0} e^{-r/2a_0} , \quad (9.145)$$

$$Y_0^0(\theta, \phi) = \sqrt{\frac{1}{4\pi}} , \quad (9.146)$$

$$Y_1^{-1}(\theta, \phi) = \frac{1}{2} \sqrt{\frac{3}{2\pi}} \sin \theta e^{-i\phi} , \quad (9.147)$$

$$Y_1^0(\theta, \phi) = \frac{1}{2} \sqrt{\frac{3}{\pi}} \cos \theta , \quad (9.148)$$

$$Y_1^1(\theta, \phi) = -\frac{1}{2} \sqrt{\frac{3}{2\pi}} \sin \theta e^{i\phi} , \quad (9.149)$$

and the corresponding eigenenergies are given by

$$E_n^{(0)} = -\frac{E_1}{n^2} , \quad (9.150)$$

where

$$E_1 = \frac{m_e e^4}{2\hbar^2} . \quad (9.151)$$

The perturbation term V in the Hamiltonian is given by

$$V = eEz = eEr \cos \theta . \quad (9.152)$$

The matrix elements of V are expressed as

$$\langle n'l'm' | V | nlm \rangle = eE \int_0^\infty dr r^3 R_{n'l'} R_{nl} \int_{-1}^1 d(\cos \theta) \int_0^{2\pi} d\phi \cos \theta \left(Y_l^{m'} \right)^* Y_l^m . \quad (9.153)$$

a) Disregarding spin this level is non degenerate. To 1st order

$$E_1 = E_1^{(0)} + \langle 1, 0, 0 | V | 1, 0, 0 \rangle = E_1^{(0)} ,$$

since

$$\int_{-1}^1 d(\cos \theta) \cos \theta = 0 ,$$

thus the energy of the ground state is unchanged to 1st order.

b) The level $n = 2$ has degeneracy 4. The matrix of the perturbation V in the degenerate subspace is given by

$$M = \begin{pmatrix} \langle 2, 0, 0 | V | 2, 0, 0 \rangle & \langle 2, 0, 0 | V | 2, 1, -1 \rangle & \langle 2, 0, 0 | V | 2, 1, 0 \rangle & \langle 2, 0, 0 | V | 2, 1, 1 \rangle \\ \langle 2, 1, -1 | V | 2, 0, 0 \rangle & \langle 2, 1, -1 | V | 2, 1, -1 \rangle & \langle 2, 1, -1 | V | 2, 1, 0 \rangle & \langle 2, 1, -1 | V | 2, 1, 1 \rangle \\ \langle 2, 1, 0 | V | 2, 0, 0 \rangle & \langle 2, 1, 0 | V | 2, 1, -1 \rangle & \langle 2, 1, 0 | V | 2, 1, 0 \rangle & \langle 2, 1, 0 | V | 2, 1, 1 \rangle \\ \langle 2, 1, 1 | V | 2, 0, 0 \rangle & \langle 2, 1, 1 | V | 2, 1, -1 \rangle & \langle 2, 1, 1 | V | 2, 1, 0 \rangle & \langle 2, 1, 1 | V | 2, 1, 1 \rangle \end{pmatrix} . \quad (9.154)$$

Using

$$\int_{-1}^1 d(\cos \theta) \cos \theta = 0 , \quad (9.155)$$

$$\int_{-1}^1 d(\cos \theta) \cos \theta \sin \theta = 0 , \quad (9.156)$$

$$\int_{-1}^1 d(\cos \theta) \cos \theta \sin^2 \theta = 0 , \quad (9.157)$$

$$\int_{-1}^1 d(\cos \theta) \cos^3 \theta = 0 , \quad (9.158)$$

$$\int_0^{2\pi} d\phi e^{\pm i\phi} = 0 , \quad (9.159)$$

one finds

$$M = \begin{pmatrix} 0 & 0 & \gamma & 0 \\ 0 & 0 & 0 & 0 \\ \gamma^* & 0 & 0 & 0 \\ 0 & 0 & 0 & 0 \end{pmatrix}, \quad (9.160)$$

where

$$\begin{aligned} \gamma &= \langle 2, 0, 0 | V | 2, 1, 0 \rangle \\ &= eE \int_0^\infty dr r^3 R_{2,0} R_{2,1} \int_{-1}^1 d(\cos \theta) \int_0^{2\pi} d\phi \cos \theta (Y_0^0)^* Y_1^0 \\ &= \frac{eE}{8} \int_0^\infty dr \left(2 - \frac{r}{a_0}\right) \left(\frac{r}{a_0}\right)^4 e^{-\frac{r}{a_0}} \\ &\quad \times \frac{1}{4\pi} \int_{-1}^1 d(\cos \theta) \cos^2 \theta \int_0^{2\pi} d\phi. \end{aligned} \quad (9.161)$$

Using

$$\int_{-1}^1 d(\cos \theta) \cos^2 \theta = \frac{2}{3}, \quad (9.162)$$

and

$$\int_0^\infty x^4 e^{-x} dx = 24 \quad (9.163)$$

$$\int_0^\infty x^5 e^{-x} dx = 120 \quad (9.164)$$

one finds

$$\begin{aligned} \gamma &= \langle 2, 0, 0 | V | 2, 1, 0 \rangle \\ &= \frac{eE}{24} \int_0^\infty dr \left(2 - \frac{r}{a_0}\right) \left(\frac{r}{a_0}\right)^4 e^{-\frac{r}{a_0}} \\ &= \frac{a_0 eE}{24} \int_0^\infty dx (2 - x) x^4 e^{-x} \\ &= -3a_0 eE. \end{aligned} \quad (9.165)$$

The eigenvalues of the matrix M are $0, 0, 3a_0 eE$ and $-3a_0 eE$. Thus to 1st order the degeneracy is partially lifted with subspace of dimension 2 having energy $E_2^{(0)}$, and another 2 nondegenerate subspaces having energies $E_2^{(0)} \pm 3a_0 eE$.

7. For $E = 0$ the normalized wavefunctions $\psi_{n_x, n_y, n_z}^{(0)}(x', y', z')$ are given by

$$\begin{aligned} & \psi_{n_x, n_y, n_z}^{(0)}(x', y', z') \\ &= \langle x', y', z' | n_x, n_y, n_z \rangle \\ &= \left(\frac{2}{l}\right)^{3/2} \sin \frac{n_x \pi (x' + \frac{l}{2})}{l} \sin \frac{n_y \pi (y' + \frac{l}{2})}{l} \sin \frac{n_z \pi (z' + \frac{l}{2})}{l}, \end{aligned} \quad (9.166)$$

and the corresponding eigenenergies are

$$E_{n_x, n_y, n_z}^{(0)} = \frac{\hbar^2 \pi^2 (n_x^2 + n_y^2 + n_z^2)}{2ml^2}, \quad (9.167)$$

where $n_x, n_y, n_z \in \{1, 2, \dots\}$. The matrix elements of the perturbation $V = qEz$ are given by

$$\langle n'_x, n'_y, n'_z | V | n''_x, n''_y, n''_z \rangle = \frac{2qE}{l} \delta_{n'_x, n''_x} \delta_{n'_y, n''_y} I_{n'_z, n''_z}, \quad (9.168)$$

where

$$I_{n'_z, n''_z} = \int_{-l/2}^{l/2} dz' \sin \frac{n''_z \pi (z' + \frac{l}{2})}{l} \sin \frac{n'_z \pi (z' + \frac{l}{2})}{l} z'. \quad (9.169)$$

Note that $I_{n'_z, n''_z} = 0$ if $n'_z = n''_z$ (since for that case the integrand is an odd function of z'), and thus

$$\langle n'_x, n'_y, n'_z | V | n''_x, n''_y, n''_z \rangle \propto \delta_{n'_x, n''_x} \delta_{n'_y, n''_y} (1 - \delta_{n'_z, n''_z}). \quad (9.170)$$

With the help of the above result it is easy to see that all the matrix elements $\langle n'_x, n'_y, n'_z | V | n''_x, n''_y, n''_z \rangle$ that are needed for first order perturbation theory, for both non-degenerate and degenerate energy levels, vanish, and consequently, to first order in E the energy eigenstates remain unchanged.

8. To lowest order in perturbation theory the ground state energy is given by

$$E_{\text{gs}} = \hbar\omega + \lambda m\omega^2 \int_{-\infty}^{\infty} dx_1 \int_{-\infty}^{\infty} dx_2 \varphi_0^2(x_1 - a) \varphi_0^2(x_2 + a) (x_1 - x_2)^2 + O(\lambda^2), \quad (9.171)$$

where $\varphi_0(x)$ is the ground state wavefunction of a particle having mass m confined by a potential $(1/2)m\omega^2 x^2$ centered at $x = 0$. Employing the transformation

$$x'_1 = x_1 - a, \quad (9.172)$$

$$x'_2 = x_2 + a, \quad (9.173)$$

and Eq. (5.154) one finds that

$$\begin{aligned}
 E_{\text{gs}} &= \hbar\omega \\
 &+ \lambda m\omega^2 \int_{-\infty}^{\infty} dx'_1 \varphi_0^2(x'_1) (x'_1 + a)^2 \\
 &+ \lambda m\omega^2 \int_{-\infty}^{\infty} dx'_2 \varphi_0^2(x'_2) (x'_2 + a)^2 \\
 &- 2\lambda m\omega^2 \int_{-\infty}^{\infty} dx'_1 \varphi_0^2(x'_1) (x'_1 + a) \int_{-\infty}^{\infty} dx'_2 \varphi_0^2(x'_2) (x'_2 - a) \\
 &+ O(\lambda^2) \\
 &= \hbar\omega + 2\lambda m\omega^2 \left(\frac{\hbar}{2m\omega} + a^2 \right) + 2\lambda m\omega^2 a^2 + O(\lambda^2) \\
 &= \hbar\omega + \lambda (\hbar\omega + 4m\omega^2 a^2) + O(\lambda^2) .
 \end{aligned} \tag{9.174}$$

Note that this problem can be also solved exactly by employing the coordinate transformation

$$x_+ = \frac{x_1 + x_2}{\sqrt{2}} , \tag{9.175}$$

$$x_- = \frac{x_1 - x_2}{\sqrt{2}} . \tag{9.176}$$

The inverse transformation is given by

$$x_1 = \frac{x_+ + x_-}{\sqrt{2}} , \tag{9.177}$$

$$x_2 = \frac{x_+ - x_-}{\sqrt{2}} . \tag{9.178}$$

The following holds

$$x_1^2 + x_2^2 = x_+^2 + x_-^2 , \tag{9.179}$$

and

$$\dot{x}_1^2 + \dot{x}_2^2 = \dot{x}_+^2 + \dot{x}_-^2 . \tag{9.180}$$

Thus, the Lagrangian of the system can be written as

$$\begin{aligned}
 \mathcal{L} &= \frac{m(\dot{x}_1^2 + \dot{x}_2^2)}{2} - V(x_1, x_2) \\
 &= \frac{m(\dot{x}_+^2 + \dot{x}_-^2)}{2} - \frac{1}{2}m\omega^2 \left(x_+^2 + x_-^2 - 2a\sqrt{2}x_- + 2a^2 + 4\lambda x_-^2 \right) \\
 &= \mathcal{L}_+ + \mathcal{L}_- ,
 \end{aligned} \tag{9.181}$$

where

$$\mathcal{L}_+ = \frac{m\dot{x}_+^2}{2} - \frac{1}{2}m\omega^2 x_+^2, \quad (9.182)$$

and

$$\mathcal{L}_- = \frac{m\dot{x}_-^2}{2} - \frac{1}{2}m\omega^2 \left[(1+4\lambda) \left(x_- - \frac{a\sqrt{2}}{1+4\lambda} \right)^2 + \frac{8\lambda a^2}{1+4\lambda} \right]. \quad (9.183)$$

Thus, the system is composed of two decoupled harmonic oscillators, and therefore, the exact eigenenergies are given by

$$E_{n_+, n_-} = \hbar\omega \left(n_+ + \frac{1}{2} \right) + \hbar\omega\sqrt{1+4\lambda} \left(n_- + \frac{1}{2} \right) + \frac{4\lambda m\omega^2 a^2}{1+4\lambda}, \quad (9.184)$$

where $n_+, n_- = 0, 1, 2, \dots$. To first order in λ one thus has

$$E_{n_+, n_-} = \hbar\omega \left(n_+ + \frac{1}{2} \right) + \hbar\omega \left(n_- + \frac{1}{2} \right) + \lambda [\hbar\omega (2n_- + 1) + 4m\omega^2 a^2] + O(\lambda^2). \quad (9.185)$$

9. For $w_0 = 0$ the normalized wavefunctions $\psi_n^{(0)}(x)$ are given by

$$\psi_n^{(0)}(x) = \langle x' | n \rangle = \sqrt{\frac{2}{l}} \sin \frac{n\pi x'}{l}, \quad (9.186)$$

and the corresponding eigenenergies are

$$E_n^{(0)} = \frac{\hbar^2 \pi^2 n^2}{2ml^2}. \quad (9.187)$$

The matrix elements of the perturbation are given by

$$\begin{aligned} \langle n | W | m \rangle &= \frac{2w_0}{l} \int_0^l \sin \frac{n\pi x}{l} \sin \frac{m\pi x}{l} \delta \left(x - \frac{l}{2} \right) dx \\ &= \frac{2w_0}{l} \sin \frac{n\pi}{2} \sin \frac{m\pi}{2}. \end{aligned} \quad (9.188)$$

For the ground state

$$\langle 1 | V | 1 \rangle = \frac{2w_0}{l}, \quad (9.189)$$

thus

$$E_1 = \frac{\hbar^2 \pi^2}{2ml^2} + \frac{2w_0}{l} + O(w_0^2). \quad (9.190)$$

10. For $w_0 = 0$ the normalized wavefunctions $\psi_{n_x, n_y}^{(0)}(x, y)$ are given by

$$\psi_{n_x, n_y}^{(0)}(x', y') = \langle x', y' | n_x, n_y \rangle = \frac{2}{a} \sin \frac{n_x \pi x'}{a} \sin \frac{n_y \pi y'}{a}, \quad (9.191)$$

and the corresponding eigenenergies are

$$E_{n_x, n_y}^{(0)} = \frac{\hbar^2 \pi^2 (n_x^2 + n_y^2)}{2ma^2}, \quad (9.192)$$

where $n_x = 1, 2, \dots$ and $n_y = 1, 2, \dots$.

a) The ground state $(n_x, n_y) = (1, 1)$ is nondegenerate, thus to first order in w_0

$$\begin{aligned} E_0 &= \frac{\hbar^2 \pi^2}{ma^2} + \langle 1, 1 | W | 1, 1 \rangle \\ &= \frac{\hbar^2 \pi^2}{ma^2} + \frac{4w_0}{a^2} \int_0^{a/2} \sin^2 \frac{\pi x}{a} dx \int_0^{a/2} \sin^2 \frac{\pi y}{a} dy \\ &= \frac{\hbar^2 \pi^2}{ma^2} + \frac{w_0}{4}, \end{aligned} \quad (9.193)$$

b) The first excite state is doubly degenerate. The matrix of the perturbation in the corresponding subspace is given by

$$\begin{aligned} &\begin{pmatrix} \langle 1, 2 | W | 1, 2 \rangle & \langle 1, 2 | W | 2, 1 \rangle \\ \langle 2, 1 | W | 1, 2 \rangle & \langle 2, 1 | W | 2, 1 \rangle \end{pmatrix} \\ &= \frac{4w_0}{a^2} \begin{pmatrix} \int_0^{a/2} \sin^2 \frac{\pi x}{a} dx \int_0^{a/2} \sin^2 \frac{2\pi y}{a} dy & \int_0^{a/2} \sin \frac{\pi x}{a} \sin \frac{2\pi x}{a} dx \int_0^{a/2} \sin \frac{2\pi y}{a} \sin \frac{\pi y}{a} dy \\ \int_0^{a/2} \sin \frac{2\pi x}{a} \sin \frac{\pi x}{a} dx \int_0^{a/2} \sin \frac{\pi y}{a} \sin \frac{2\pi y}{a} dy & \int_0^{a/2} \sin^2 \frac{2\pi x}{a} dx \int_0^{a/2} \sin^2 \frac{\pi y}{a} dy \end{pmatrix} \\ &= w_0 \begin{pmatrix} \frac{1}{4} & \frac{16}{9\pi^2} \\ \frac{16}{9\pi^2} & \frac{1}{4} \end{pmatrix}, \end{aligned} \quad (9.194)$$

To first order in perturbation theory the eigenenergies are found by adding the eigenvalues of the above matrix to the unperturbed eigenenergy $E_{1,2}^{(0)} = E_{2,1}^{(0)}$. Thus, to first order in w_0

$$E_{1,\pm} = \frac{5\hbar^2 \pi^2}{2ma^2} + \frac{w_0}{4} \pm \frac{16w_0}{9\pi^2} + O(w_0^2). \quad (9.195)$$

11. For the unperturbed case $\beta = 0$ one has

$$H_0 |n_x, n_y\rangle = \hbar\omega (n_x + n_y + 1) |n_x, n_y\rangle, \quad (9.196)$$

where $n_x, n_y = 0, 1, 2, \dots$. Using the identities

$$x = \sqrt{\frac{\hbar}{2m\omega}} (a_x + a_x^\dagger) , \quad (9.197)$$

$$y = \sqrt{\frac{\hbar}{2m\omega}} (a_y + a_y^\dagger) , \quad (9.198)$$

the perturbation term $V_1 = \beta m\omega^2 xy$ can be expressed as

$$V_1 = \beta \frac{\hbar\omega}{2} (a_x + a_x^\dagger) (a_y + a_y^\dagger) .$$

a) For the ground state $|0, 0\rangle$, which is nondegenerate, one has

$$\begin{aligned} E_{0,0}(\beta) &= \hbar\omega + \underbrace{\langle 0, 0 | V_1 | 0, 0 \rangle}_{=0} + \sum_{n_x, n_y \neq 0, 0} \frac{|\langle n_x, n_y | V_1 | 0, 0 \rangle|^2}{E_{0,0}(0) - E_{n_x, n_y}} \\ &= \hbar\omega + \frac{|\langle 1, 1 | V_1 | 0, 0 \rangle|^2}{2\hbar\omega} \\ &= \hbar\omega - \frac{\left(\frac{\hbar\omega\beta}{2}\right)^2}{2\hbar\omega} \\ &= \hbar\omega \left(1 - \frac{\beta^2}{8}\right) . \end{aligned} \quad (9.199)$$

b) The first excited state is doubly degenerate, thus the eigenenergies are found by diagonalizing the matrix of V_1 in the corresponding subspace

$$\begin{pmatrix} \langle 1, 0 | V_1 | 1, 0 \rangle & \langle 1, 0 | V_1 | 0, 1 \rangle \\ \langle 0, 1 | V_1 | 1, 0 \rangle & \langle 0, 1 | V_1 | 0, 1 \rangle \end{pmatrix} = \frac{\hbar\omega\beta}{2} \begin{pmatrix} 0 & 1 \\ 1 & 0 \end{pmatrix} . \quad (9.200)$$

Thus the degeneracy is lifted and the energies are given by $2\hbar\omega (1 \pm \beta/4)$. Note that this problem can be also solved exactly by employing the coordinate transformation

$$x' = \frac{x + y}{\sqrt{2}} , \quad (9.201)$$

$$y' = \frac{x - y}{\sqrt{2}} . \quad (9.202)$$

The inverse transformation is given by

$$x = \frac{x' + y'}{\sqrt{2}} , \quad (9.203)$$

$$y = \frac{x' - y'}{\sqrt{2}} . \quad (9.204)$$

The following hold

$$x^2 + y^2 = x'^2 + y'^2 , \quad (9.205)$$

$$\dot{x}^2 + \dot{y}^2 = \dot{x}'^2 + \dot{y}'^2 , \quad (9.206)$$

$$xy = \frac{1}{2} (x'^2 - y'^2) . \quad (9.207)$$

Thus, the Lagrangian of the system can be written as

$$\begin{aligned}\mathcal{L} &= \frac{m(\dot{x}^2 + \dot{y}^2)}{2} - V(x_1, x_2) \\ &= \frac{m(\dot{x}'^2 + \dot{y}'^2)}{2} - \frac{m\omega^2}{2}(x'^2 + y'^2) - \frac{\beta m\omega^2}{2}(x'^2 - y'^2) \\ &= \mathcal{L}_+ + \mathcal{L}_-, \end{aligned}\tag{9.208}$$

where

$$\mathcal{L}_+ = \frac{m\dot{x}'^2}{2} - \frac{m\omega^2}{2}(1 + \beta)x'^2, \tag{9.209}$$

and

$$\mathcal{L}_- = \frac{m\dot{y}'^2}{2} - \frac{m\omega^2}{2}(1 - \beta)y'^2. \tag{9.210}$$

Thus, the system is composed of two decoupled harmonic oscillators, and therefore, the exact eigenenergies are given by

$$E_{n_+, n_-} = \hbar\omega \left[\sqrt{1 + \beta} \left(n_x + \frac{1}{2} \right) + \sqrt{1 - \beta} \left(n_y + \frac{1}{2} \right) \right], \tag{9.211}$$

where $n_x, n_y = 0, 1, 2, \dots$. To second order in β one thus has

$$E_{n_+, n_-} = \hbar\omega \left(n_x + n_y + 1 + \frac{n_x - n_y}{2}\beta - \frac{n_x + n_y + 1}{8}\beta^2 \right) + O(\beta^3). \tag{9.212}$$

12. Using Eqs. (5.28) and (5.29) one finds that

$$\langle m|V|n\rangle = \frac{\hbar\omega_1}{2}\sqrt{n(n-1)}\delta_{m, n-2} + \frac{\hbar\omega_1}{2}\sqrt{(n+1)(n+2)}\delta_{m, n+2}, \tag{9.213}$$

thus

$$\begin{aligned}E_n(\omega_1) &= \hbar\omega_0 \left(n + \frac{1}{2} \right) + \underbrace{\langle n|V|n\rangle}_{=0} + \sum_{m \neq n} \frac{|\langle m|V|n\rangle|^2}{E_n(0) - E_m(0)} + O(\omega_1^3) \\ &= \hbar\omega_0 \left(n + \frac{1}{2} \right) + \frac{\hbar\omega_1^2}{8\omega_0} [n(n-1) - (n+1)(n+2)] + O(\omega_1^3) \\ &= \hbar\omega_0 \left(1 - \frac{\omega_1^2}{2\omega_0^2} \right) \left(n + \frac{1}{2} \right) + O(\omega_1^3). \end{aligned}\tag{9.214}$$

The exact energy eigenvalues can be calculated for this case as follows. The Hamiltonian \mathcal{H} including the perturbation is given by

$$\mathcal{H} = \hbar\omega_0 \left(a^\dagger a + \frac{1}{2} \right) + \frac{\hbar\omega_1}{2} (a^\dagger a^\dagger + aa) . \quad (9.215)$$

Consider the transformation

$$b = ua + va^\dagger . \quad (9.216)$$

The requirement that

$$1 = [b, b^\dagger] , \quad (9.217)$$

implies that [see Eq. (5.13)]

$$\begin{aligned} 1 &= [ua + va^\dagger, u^* a^\dagger + v^* a] \\ &= |u|^2 [a, a^\dagger] + |v|^2 [a^\dagger, a] \\ &= |u|^2 - |v|^2 . \end{aligned} \quad (9.218)$$

The above condition (9.217) is satisfied when u and v are taken to be given by

$$u = \cosh \theta , \quad (9.219)$$

$$v = \sinh \theta , \quad (9.220)$$

where θ is real. The inverse transformation is given by

$$\begin{pmatrix} \cosh \theta & -\sinh \theta \\ -\sinh \theta & \cosh \theta \end{pmatrix} \begin{pmatrix} b \\ b^\dagger \end{pmatrix} = \begin{pmatrix} a \\ a^\dagger \end{pmatrix} . \quad (9.221)$$

With the help of the identities

$$2 \sinh \theta \cosh \theta = \sinh (2\theta) , \quad (9.222)$$

$$\cosh^2 \theta + \sinh^2 \theta = \cosh (2\theta) , \quad (9.223)$$

$$\cosh^2 \theta - \sinh^2 \theta = 1 , \quad (9.224)$$

and the condition (9.217) one finds that the following holds

$$\begin{aligned} a^\dagger a &= (b^\dagger \cosh \theta - b \sinh \theta) (b \cosh \theta - b^\dagger \sinh \theta) \\ &= b^\dagger b \cosh^2 \theta + bb^\dagger \sinh^2 \theta - (b^\dagger b^\dagger + bb) \sinh \theta \cosh \theta \\ &= b^\dagger b \frac{\cosh (2\theta) + 1}{2} + bb^\dagger \frac{\cosh (2\theta) - 1}{2} - \frac{b^\dagger b^\dagger + bb}{2} \sinh (2\theta) \\ &= \left(b^\dagger b + \frac{1}{2} \right) \cosh (2\theta) - \frac{1}{2} - \frac{b^\dagger b^\dagger + bb}{2} \sinh (2\theta) , \end{aligned} \quad (9.225)$$

and

$$\begin{aligned}
 & a^\dagger a^\dagger + aa \\
 &= (b^\dagger b^\dagger + bb) (\cosh^2 \theta + \sinh^2 \theta) - 2 (b^\dagger b + bb^\dagger) \sinh \theta \cosh \theta \\
 &= (b^\dagger b^\dagger + bb) \cosh (2\theta) - (b^\dagger b + bb^\dagger) \sinh (2\theta) \\
 &= (b^\dagger b^\dagger + bb) \cosh (2\theta) - (2b^\dagger b + 1) \sinh (2\theta) ,
 \end{aligned} \tag{9.226}$$

and thus in terms of b and b^\dagger the Hamiltonian \mathcal{H} is given by

$$\begin{aligned}
 \hbar^{-1} \mathcal{H} &= [\omega_0 \cosh (2\theta) - \omega_1 \sinh (2\theta)] \left(b^\dagger b + \frac{1}{2} \right) \\
 &\quad + [\omega_1 \cosh (2\theta) - \omega_0 \sinh (2\theta)] \frac{b^\dagger b^\dagger + bb}{2} .
 \end{aligned} \tag{9.227}$$

When θ is chosen such that

$$\omega_1 \cosh (2\theta) - \omega_0 \sinh (2\theta) = 0, \tag{9.228}$$

the Hamiltonian becomes

$$\hbar^{-1} \mathcal{H} = \omega_{\text{eff}} \left(b^\dagger b + \frac{1}{2} \right) , \tag{9.229}$$

where

$$\omega_{\text{eff}} = \omega_0 \cosh (2\theta) - \omega_1 \sinh (2\theta) . \tag{9.230}$$

With the help of the identities

$$\cosh (\tanh^{-1} x) = \frac{1}{\sqrt{1-x^2}} , \tag{9.231}$$

$$\sinh (\tanh^{-1} x) = \frac{x}{\sqrt{1-x^2}} , \tag{9.232}$$

and the condition (9.228) one obtains

$$\omega_{\text{eff}} = \omega_0 \sqrt{1 - \left(\frac{\omega_1}{\omega_0} \right)^2} . \tag{9.233}$$

Thus, the exact energy eigenvalues of \mathcal{H} are

$$\begin{aligned}
 E_n &= \hbar \omega_0 \sqrt{1 - \left(\frac{\omega_1}{\omega_0} \right)^2} \left(n + \frac{1}{2} \right) \\
 &= \hbar \omega_0 \left(1 - \frac{\omega_1^2}{2\omega_0^2} \right) \left(n + \frac{1}{2} \right) + O(\omega_1^3) .
 \end{aligned} \tag{9.234}$$

in agreement with Eq. (9.214).

13. In general the subspace of angular momentum states with $j = 1$ is spanned by the basis

$$\{|j = 1, m = -1\rangle, |j = 1, m = 0\rangle, |j = 1, m = 1\rangle\}, \quad (9.235)$$

and the following holds [see Eqs. (6.63), (6.64), (6.65) and (6.66)]

$$\langle j', m' | J_z | j, m \rangle = m \hbar \delta_{j',j} \delta_{m',m}, \quad (9.236)$$

$$\langle j', m' | \mathbf{J}^2 | j, m \rangle = j(j+1) \hbar^2 \delta_{j',j} \delta_{m',m}, \quad (9.237)$$

$$\langle j', m' | J_{\pm} | j, m \rangle = \hbar \sqrt{(j \mp m)(j \pm m + 1)} \delta_{j',j} \delta_{m',m \pm 1}, \quad (9.238)$$

$$J_{\pm} = J_x \pm iJ_y. \quad (9.239)$$

In matrix form

$$J_z \doteq \hbar \begin{pmatrix} 1 & 0 & 0 \\ 0 & 0 & 0 \\ 0 & 0 & -1 \end{pmatrix}, \quad (9.240)$$

$$\mathbf{J}^2 \doteq 2\hbar^2 \begin{pmatrix} 1 & 0 & 0 \\ 0 & 1 & 0 \\ 0 & 0 & 1 \end{pmatrix}, \quad (9.241)$$

$$J_+ \doteq \hbar\sqrt{2} \begin{pmatrix} 0 & 1 & 0 \\ 0 & 0 & 1 \\ 0 & 0 & 0 \end{pmatrix}, \quad (9.242)$$

$$J_- \doteq \hbar\sqrt{2} \begin{pmatrix} 0 & 0 & 0 \\ 1 & 0 & 0 \\ 0 & 1 & 0 \end{pmatrix}. \quad (9.243)$$

- a) The Hamiltonian is given by

$$\begin{aligned} \mathcal{H} &= \alpha S_z^2 + \beta (S_x^2 - S_y^2) \\ &= \alpha S_z^2 + \frac{\beta}{4} [(S_+ + S_-)^2 + (S_+ - S_-)^2] \\ &= \alpha S_z^2 + \frac{\beta}{2} (S_+^2 + S_-^2). \end{aligned} \quad (9.244)$$

Thus, in matrix form

$$\begin{aligned} \mathcal{H} &\doteq \alpha \hbar^2 \begin{pmatrix} 1 & 0 & 0 \\ 0 & 0 & 0 \\ 0 & 0 & 1 \end{pmatrix} + \beta \hbar^2 \left(\begin{pmatrix} 0 & 0 & 1 \\ 0 & 0 & 0 \\ 0 & 0 & 0 \end{pmatrix} + \begin{pmatrix} 0 & 0 & 0 \\ 0 & 0 & 0 \\ 1 & 0 & 0 \end{pmatrix} \right) \\ &= \hbar^2 \begin{pmatrix} \alpha & 0 & \beta \\ 0 & 0 & 0 \\ \beta & 0 & \alpha \end{pmatrix}. \end{aligned} \quad (9.245)$$

- b) The eigenvalues and eigenvectors are given by

$$\hbar^2 \begin{pmatrix} \alpha & 0 & \beta \\ 0 & 0 & 0 \\ \beta & 0 & \alpha \end{pmatrix} \begin{pmatrix} 1 \\ 0 \\ 1 \end{pmatrix} = \hbar^2 (\alpha + \beta) \begin{pmatrix} 1 \\ 0 \\ 1 \end{pmatrix}, \quad (9.246)$$

$$\hbar^2 \begin{pmatrix} \alpha & 0 & \beta \\ 0 & 0 & 0 \\ \beta & 0 & \alpha \end{pmatrix} \begin{pmatrix} -1 \\ 0 \\ 1 \end{pmatrix} = \hbar^2 (\alpha - \beta) \begin{pmatrix} -1 \\ 0 \\ 1 \end{pmatrix}, \quad (9.247)$$

$$\hbar^2 \begin{pmatrix} \alpha & 0 & \beta \\ 0 & 0 & 0 \\ \beta & 0 & \alpha \end{pmatrix} \begin{pmatrix} 0 \\ 1 \\ 0 \end{pmatrix} = \hbar^2 \times 0 \begin{pmatrix} 0 \\ 1 \\ 0 \end{pmatrix}. \quad (9.248)$$

c) The Hamiltonian is written as $\mathcal{H} = \mathcal{H}_0 + V$ where in matrix form

$$\mathcal{H}_0 \doteq \hbar^2 \alpha \begin{pmatrix} 1 & 0 & 0 \\ 0 & 0 & 0 \\ 0 & 0 & 1 \end{pmatrix}, \quad (9.249)$$

$$V \doteq \hbar^2 \beta \begin{pmatrix} 0 & 0 & 1 \\ 0 & 0 & 0 \\ 1 & 0 & 0 \end{pmatrix}. \quad (9.250)$$

For the nondegenerate eigenenergy $E_{m=0}^0 = 0$ one has to second order in perturbation expansion [see Eq. (9.32)]

$$E_{m=0} = E_{m=0}^0 + \langle 1, 0 | V | 1, 0 \rangle + \sum_{m'=\pm 1} \frac{|\langle 1, m' | V | 1, 0 \rangle|^2}{E_{m=0}^0 - E_{m'}^0} = 0. \quad (9.251)$$

For the degenerate eigenenergy $E_{m=\pm 1}^0 = \hbar^2 \alpha$ the perturbation in the subspace spanned by $\{|1, -1\rangle, |1, 1\rangle\}$ is given in matrix form by

$$V_{m=\pm 1} \doteq \hbar^2 \beta \begin{pmatrix} 0 & 1 \\ 1 & 0 \end{pmatrix}, \quad (9.252)$$

thus to first order in perturbation expansion

$$E_{m=\pm 1} = \hbar^2 (\alpha \pm \beta). \quad (9.253)$$

14. In the basis of the spin states

$$\{|s = 1, m = +1\rangle, |s = 1, m = 0\rangle, |s = 1, m = -1\rangle\}$$

one has [see Eqs. (9.240), (9.241), (9.242) and (9.243)]

$$\frac{\mathcal{H}_0}{\hbar} \doteq \begin{pmatrix} D & 0 & 0 \\ 0 & 0 & 0 \\ 0 & 0 & D \end{pmatrix}, \quad (9.254)$$

and

$$\frac{\mathcal{H}_1}{\hbar} \doteq -\gamma \begin{pmatrix} B_z & \frac{B_x - iB_y}{\sqrt{2}} & -\frac{E}{\gamma} \\ \frac{B_x + iB_y}{\sqrt{2}} & 0 & \frac{B_x - iB_y}{\sqrt{2}} \\ -\frac{E}{\gamma} & \frac{B_x + iB_y}{\sqrt{2}} & -B_z \end{pmatrix}. \quad (9.255)$$

Treating \mathcal{H}_1 as small and further assuming that $E \ll D$ yield to lowest nonvanishing order in the applied magnetic field [see Eqs. (9.32) and (9.38) and note that the eigenvalue D of $\hbar^{-1}\mathcal{H}_0$ is doubly degenerate]

$$\frac{\epsilon_1}{\hbar} = D - \sqrt{(\gamma B_z)^2 + E^2} + \frac{\gamma^2 (B_x^2 + B_y^2)}{2D}, \quad (9.256)$$

$$\frac{\epsilon_2}{\hbar} = -\frac{\gamma^2 (B_x^2 + B_y^2)}{D}, \quad (9.257)$$

$$\frac{\epsilon_3}{\hbar} = D + \sqrt{(\gamma B_z)^2 + E^2} + \frac{\gamma^2 (B_x^2 + B_y^2)}{2D}, \quad (9.258)$$

thus the angular resonance frequencies ω_{\mp} corresponding to the transitions between the ground state (having energy ϵ_2) and the excited states (having energies ϵ_1 and ϵ_3) are given by

$$\begin{aligned} \omega_{\mp} &= \frac{\epsilon_{1,3} - \epsilon_2}{\hbar} \\ &= D \mp \sqrt{(\gamma B_{\parallel})^2 + E^2} + \frac{3}{2} \frac{\gamma^2 B_{\perp}^2}{D}, \end{aligned} \quad (9.259)$$

where $B_{\parallel} = B_z$ is the magnetic field component parallel to the axis of the NV defect and where $B_{\perp} = \sqrt{B_x^2 + B_y^2}$ is the transverse one.

15. For simplicity, the angle φ_B is assumed to vanish, i.e. $\hat{\mathbf{n}}_B = (\sin \theta_B, 0, \cos \theta_B)$ (by symmetry, the eigenenergies of \mathcal{H} are independent on φ_B). For this case the rotation matrix $R_{\hat{\mathbf{n}}_B}$ becomes [see Eq. (6.286)]

$$R_{\hat{\mathbf{n}}_B} = \begin{pmatrix} \cos \theta_B & 0 & -\sin \theta_B \\ 0 & \cos \theta_B & 0 \\ \sin \theta_B & 0 & \cos \theta_B \end{pmatrix}. \quad (9.260)$$

All term in the Hamiltonian can be represented by 6×6 matrices in the basis of the $|m_e, m_n\rangle$ states given by

$$\left\{ \left| \frac{1}{2}, 1 \right\rangle, \left| \frac{1}{2}, 0 \right\rangle, \left| \frac{1}{2}, -1 \right\rangle, \left| -\frac{1}{2}, 1 \right\rangle, \left| -\frac{1}{2}, 0 \right\rangle, \left| -\frac{1}{2}, -1 \right\rangle \right\}, \quad (9.261)$$

where $m_e \in \{-1/2, +1/2\}$ ($m_n \in \{-1, 0, +1\}$) is the electron (nuclear) magnetic quantum number. The electron spin operators S_n in a block form are expressed as

$$(\hbar/2)^{-1} S_n \doteq F^T \begin{pmatrix} \sigma_n & 0 & 0 \\ 0 & \sigma_n & 0 \\ 0 & 0 & \sigma_n \end{pmatrix} F, \quad (9.262)$$

where $n \in (x, y, z)$, σ_n is a Pauli matrix [see Eq. (6.137)], and where the matrix F , which is given by

$$F = \begin{pmatrix} 1 & 0 & 0 & 0 & 0 & 0 \\ 0 & 0 & 0 & 1 & 0 & 0 \\ 0 & 1 & 0 & 0 & 0 & 0 \\ 0 & 0 & 0 & 0 & 1 & 0 \\ 0 & 0 & 1 & 0 & 0 & 0 \\ 0 & 0 & 0 & 0 & 0 & 1 \end{pmatrix}, \quad (9.263)$$

represents the basis transformation from

$$\left\{ \left| \frac{1}{2}, 1 \right\rangle, \left| \frac{1}{2}, 0 \right\rangle, \left| \frac{1}{2}, -1 \right\rangle, \left| -\frac{1}{2}, 1 \right\rangle, \left| -\frac{1}{2}, 0 \right\rangle, \left| -\frac{1}{2}, -1 \right\rangle \right\}$$

to

$$\left\{ \left| \frac{1}{2}, 1 \right\rangle, \left| -\frac{1}{2}, 1 \right\rangle, \left| \frac{1}{2}, 0 \right\rangle, \left| -\frac{1}{2}, 0 \right\rangle, \left| \frac{1}{2}, -1 \right\rangle, \left| -\frac{1}{2}, -1 \right\rangle \right\}.$$

The nuclear spin operators I_n in a block form are expressed as

$$\hbar^{-1} I_n \doteq \begin{pmatrix} A_n & 0 \\ 0 & A_n \end{pmatrix}, \quad (9.264)$$

where [see Eqs. (9.240), (9.241), (9.242) and (9.243)]

$$A_x = \frac{1}{\sqrt{2}} \begin{pmatrix} 0 & 1 & 0 \\ 1 & 0 & 1 \\ 0 & 1 & 0 \end{pmatrix}, \quad (9.265)$$

$$A_y = \frac{i}{\sqrt{2}} \begin{pmatrix} 0 & -1 & 0 \\ 1 & 0 & -1 \\ 0 & 1 & 0 \end{pmatrix}, \quad (9.266)$$

$$A_z = \begin{pmatrix} 1 & 0 & 0 \\ 0 & 0 & 0 \\ 0 & 0 & -1 \end{pmatrix}. \quad (9.267)$$

The following holds in a block form

$$\begin{aligned} \hbar^{-1} \mathcal{H}_e &\doteq \frac{\gamma_e B}{2} F^T \begin{pmatrix} \sigma_z & 0 & 0 \\ 0 & \sigma_z & 0 \\ 0 & 0 & \sigma_z \end{pmatrix} F \\ &= \frac{\gamma_e B}{2} \begin{pmatrix} \mathbf{1} & 0 \\ 0 & -\mathbf{1} \end{pmatrix}, \end{aligned} \quad (9.268)$$

where $\mathbf{1}$ is a 3×3 identity matrix, and

$$\hbar^{-2} Q I_z^2 \doteq Q \begin{pmatrix} A_z^2 & 0 \\ 0 & A_z^2 \end{pmatrix}, \quad (9.269)$$

and

$$\sigma_x A_x = \begin{pmatrix} 0 & A_x \\ A_x & 0 \end{pmatrix}, \quad \sigma_x A_z = \begin{pmatrix} 0 & A_z \\ A_z & 0 \end{pmatrix}, \quad (9.270)$$

$$\sigma_y A_y = \begin{pmatrix} 0 & -iA_y \\ iA_y & 0 \end{pmatrix}, \quad (9.271)$$

$$\sigma_z A_x = \begin{pmatrix} A_x & 0 \\ 0 & -A_x \end{pmatrix}, \quad \sigma_z A_z = \begin{pmatrix} A_z & 0 \\ 0 & -A_z \end{pmatrix}. \quad (9.272)$$

With the help of the following identity

$$\begin{aligned} & R_{\hat{\mathbf{n}}_B}^{-1} \mathcal{A} R_{\hat{\mathbf{n}}_B} \\ &= \begin{pmatrix} A_{\perp} \cos^2 \theta_B + A_{\parallel} \sin^2 \theta_B & 0 & \frac{(A_{\parallel} - A_{\perp}) \sin(2\theta_B)}{2} \\ 0 & A_{\perp} & 0 \\ \frac{(A_{\parallel} - A_{\perp}) \sin(2\theta_B)}{2} & 0 & A_{\perp} \sin^2 \theta_B + A_{\parallel} \cos^2 \theta_B \end{pmatrix}, \end{aligned} \quad (9.273)$$

one finds that

$$\hbar^{-1} \mathcal{H}_{\text{en}} \doteq \begin{pmatrix} M_{11} & M_{12} \\ M_{21} & M_{22} \end{pmatrix}, \quad (9.274)$$

where

$$M_{11} = \Omega_A \cdot \mathbf{A} = -M_{22}, \quad (9.275)$$

$$M_{12} = \Omega_{12} \cdot \mathbf{A}, \quad (9.276)$$

$$M_{21} = \Omega_{21} \cdot \mathbf{A}, \quad (9.277)$$

and where

$$\mathbf{A} = (A_x \ A_y \ A_z), \quad (9.278)$$

$$\Omega_A = \left(\frac{(A_{\parallel} - A_{\perp}) \sin(2\theta_B)}{4} \ 0 \ \frac{A_{\parallel} \cos^2 \theta_B + A_{\perp} \sin^2 \theta_B}{2} \right), \quad (9.279)$$

$$\Omega_{12} = \left(\frac{A_{\parallel} \sin^2 \theta_B + A_{\perp} \cos^2 \theta_B}{2} \ \frac{-iA_{\perp}}{2} \ \frac{(A_{\parallel} - A_{\perp}) \sin(2\theta_B)}{4} \right), \quad (9.280)$$

$$\Omega_{21} = \left(\frac{A_{\parallel} \sin^2 \theta_B + A_{\perp} \cos^2 \theta_B}{2} \ \frac{iA_{\perp}}{2} \ \frac{(A_{\parallel} - A_{\perp}) \sin(2\theta_B)}{4} \right), \quad (9.281)$$

or

$$\Omega_{12} = \frac{(A_{\parallel} - A_{\perp}) \sin \theta_B}{2} \hat{\mathbf{n}}_B + \frac{A_{\perp}}{2} \mathbf{v}_-, \quad (9.282)$$

$$\Omega_{21} = \frac{(A_{\parallel} - A_{\perp}) \sin \theta_B}{2} \hat{\mathbf{n}}_B + \frac{A_{\perp}}{2} \mathbf{v}_+, \quad (9.283)$$

where

$$\hat{\mathbf{n}}_{\mathbf{B}} = (\sin \theta_{\mathbf{B}}, 0, \cos \theta_{\mathbf{B}}) , \quad (9.284)$$

$$\mathbf{v}_{\pm} = (1, \pm i, 0) . \quad (9.285)$$

The vector $\Omega_{\mathbf{A}}$ can be expressed as

$$\Omega_{\mathbf{A}} = \omega_{\mathbf{A}} \hat{\mathbf{n}}_{\mathbf{A}} , \quad (9.286)$$

where the angular frequency $\omega_{\mathbf{A}}$ is given by

$$\omega_{\mathbf{A}} = \frac{1}{2} \sqrt{A_{\parallel}^2 \cos^2 \theta_{\mathbf{B}} + A_{\perp}^2 \sin^2 \theta_{\mathbf{B}}} , \quad (9.287)$$

the unit vector $\hat{\mathbf{n}}_{\mathbf{A}}$ by

$$\hat{\mathbf{n}}_{\mathbf{A}} = (\sin \theta_{\mathbf{A}}, 0, \cos \theta_{\mathbf{A}}) , \quad (9.288)$$

where the angles $\theta_{\mathbf{A}}$ and $\theta_{\mathbf{B}}$ are related by [see Eq. (9.287)]

$$\theta_{\mathbf{A}} = \theta_{\mathbf{B}} - \tan^{-1} \left(\frac{A_{\perp}}{A_{\parallel}} \tan \theta_{\mathbf{B}} \right) . \quad (9.289)$$

Consider the unitary transformation

$$U_y(\theta_{\mathbf{A}}) = \exp \left(-\frac{i\theta_{\mathbf{A}} I_y}{\hbar} \right) . \quad (9.290)$$

The following holds [see Eq. (9.266)]

$$A_y^n = \begin{cases} A_y & n \text{ odd} \\ \begin{pmatrix} \frac{1}{2} & 0 & -\frac{1}{2} \\ 0 & 1 & 0 \\ -\frac{1}{2} & 0 & \frac{1}{2} \end{pmatrix} & n \text{ even} \end{cases} , \quad (9.291)$$

and thus the matrix representation of $U_y(\theta_{\mathbf{A}})$ is given by

$$U_y(\theta_{\mathbf{A}}) \doteq R_y(\theta_{\mathbf{A}}) , \quad (9.292)$$

where

$$\begin{aligned} R_y(\theta_{\mathbf{A}}) &= \exp(-i\theta_{\mathbf{A}} A_y) \\ &= 1 - A_y^2 (1 - \cos \theta_{\mathbf{A}}) - i A_y \sin \theta_{\mathbf{A}} \\ &= \begin{pmatrix} \frac{1+\cos \theta_{\mathbf{A}}}{2} & -\frac{\sin \theta_{\mathbf{A}}}{\sqrt{2}} & \frac{1-\cos \theta_{\mathbf{A}}}{2} \\ \frac{\sin \theta_{\mathbf{A}}}{\sqrt{2}} & \cos \theta_{\mathbf{A}} & -\frac{\sin \theta_{\mathbf{A}}}{\sqrt{2}} \\ \frac{1-\cos \theta_{\mathbf{A}}}{2} & \frac{\sin \theta_{\mathbf{A}}}{\sqrt{2}} & \frac{1+\cos \theta_{\mathbf{A}}}{2} \end{pmatrix} . \end{aligned} \quad (9.293)$$

The following holds

$$R_y^{-1}(\theta_A) \hat{\mathbf{n}}_A \cdot \mathbf{A} R_y(\theta_A) = A_z . \quad (9.294)$$

Consider the following matrix transformation

$$M \rightarrow M' = \mathcal{R}_y^{-1}(\theta_A) M \mathcal{R}_y(\theta_A) , \quad (9.295)$$

where in a block form

$$\mathcal{R}_y(\theta_A) = \left(\begin{array}{c|c} R_y(\theta_A) & 0 \\ \hline 0 & R_y(\theta_A) \end{array} \right) . \quad (9.296)$$

The following holds [see Eqs. (9.268), (9.269) and (9.274)]

$$\hbar^{-1} \mathcal{H}'_e \doteq \frac{\gamma_e B}{2} \left(\begin{array}{c|c} \mathbf{1} & 0 \\ \hline 0 & -\mathbf{1} \end{array} \right) , \quad (9.297)$$

$$\hbar^{-2} Q (I_z^2)' \doteq Q \left(\begin{array}{c|c} (A'_z)^2 & 0 \\ \hline 0 & (A'_z)^2 \end{array} \right) , \quad (9.298)$$

where

$$A'_z = -A_x \sin \theta_A + A_z \cos \theta_A , \quad (9.299)$$

and [see Eqs. (9.275), (9.286) and (9.294)]

$$\hbar^{-1} \mathcal{H}'_{\text{en}} \doteq \left(\begin{array}{c|c} \omega_A A_z & M'_{12} \\ \hline M'_{21} & -\omega_A A_z \end{array} \right) , \quad (9.300)$$

where

$$M'_{12} = R_y^{-1}(\theta_A) M_{12} R_y(\theta_A) , \quad (9.301)$$

$$M'_{21} = R_y^{-1}(\theta_A) M_{21} R_y(\theta_A) . \quad (9.302)$$

Moreover

$$\begin{aligned} & R_y^{-1}(\theta_A) (\hat{\mathbf{n}}_B \cdot \mathbf{A}) R_y(\theta_A) \\ &= -\sin(\theta_A - \theta_B) A_x + \cos(\theta_A - \theta_B) A_z , \end{aligned} \quad (9.303)$$

$$\begin{aligned} & R_y^{-1}(\theta_A) (\mathbf{v}_{\pm} \cdot \mathbf{A}) R_y(\theta_A) \\ &= A_z \sin \theta_A - A_{\mp} \sin^2 \frac{\theta_A}{2} + A_{\pm} \cos^2 \frac{\theta_A}{2} , \end{aligned} \quad (9.304)$$

where

$$A_{\pm} = A_x \pm iA_y, \quad (9.305)$$

and thus [see Eq. (9.282)]

$$\begin{aligned} M'_{12} &= \frac{(A_{\parallel} - A_{\perp}) [-A_x \sin(\theta_A - \theta_B) + A_z \cos(\theta_A - \theta_B)] \sin \theta_B}{2} \\ &+ \frac{A_{\perp} (A_z \sin \theta_A - A_+ \sin^2 \frac{\theta_A}{2} + A_- \cos^2 \frac{\theta_A}{2})}{2}, \end{aligned} \quad (9.306)$$

or

$$M'_{12} = \omega_{\perp+} A_+ + \omega_{\perp-} A_- + \omega_{\perp z} A_z, \quad (9.307)$$

where

$$\omega_{\perp+} = -\frac{(A_{\parallel} - A_{\perp}) \sin(\theta_A - \theta_B) \sin \theta_B + 2A_{\perp} \sin^2 \frac{\theta_A}{2}}{4}, \quad (9.308)$$

$$\omega_{\perp-} = -\frac{(A_{\parallel} - A_{\perp}) \sin(\theta_A - \theta_B) \sin \theta_B - 2A_{\perp} \cos^2 \frac{\theta_A}{2}}{4}, \quad (9.309)$$

$$\omega_{\perp z} = \frac{(A_{\parallel} - A_{\perp}) \cos(\theta_A - \theta_B) \sin \theta_B + A_{\perp} \sin \theta_A}{2}, \quad (9.310)$$

and

$$M'_{21} = M'_{12}{}^{\dagger}. \quad (9.311)$$

The following holds

$$(\hbar/2)^{-1} S_+ \doteq 2 \begin{pmatrix} \boxed{0} & \boxed{1} \\ \boxed{0} & \boxed{0} \end{pmatrix}, \quad (9.312)$$

$$(\hbar/2)^{-1} S_- \doteq 2 \begin{pmatrix} \boxed{0} & \boxed{0} \\ \boxed{1} & \boxed{0} \end{pmatrix}, \quad (9.313)$$

where

$$S_{\pm} = S_x \pm iS_y, \quad (9.314)$$

and therefore the Hamiltonian \mathcal{H}'_{en} can be expressed as [see Eqs. (9.300) and (9.307)]

$$\hbar \mathcal{H}'_{\text{en}} = 2\omega_A I'_z S_z \quad (9.315)$$

$$\begin{aligned} &+ \omega_{\perp+} (I'_+ S_+ + I'_- S_-) + \omega_{\perp-} (I'_- S_+ + I'_+ S_-) \\ &+ \omega_{\perp z} I'_z (S_+ + S_-). \end{aligned} \quad (9.316)$$

Similarly [see Eq. (9.268)]

$$\mathcal{H}_e = \gamma_e B S_z , \quad (9.317)$$

and [see Eq. (9.298) and recall that the term $\gamma_n \mathbf{B} \cdot \mathbf{I}$ is disregarded]

$$\hbar \mathcal{H}_n = Q I_z'^2 . \quad (9.318)$$

To first order in perturbation theory (and in the limit of high applied magnetic field B) the off diagonal terms of \mathcal{H}'_{en} (9.315) (proportional to $\omega_{\perp+}$, $\omega_{\perp-}$ and $\omega_{\perp z}$) are disregarded, and thus in this approximation the energy eigenvalues ϵ_{m_e, m_n} of $\mathcal{H} = \mathcal{H}_e + \mathcal{H}_n + \mathcal{H}_{en}$ (9.75) are given by [see Eq. (6.64)]

$$\hbar^{-1} \epsilon_{m_e, m_n} = m_e \gamma_e B + m_n^2 Q + 2m_e m_n \omega_A , \quad (9.319)$$

where $m_e \in \{-1/2, +1/2\}$ and where $m_n \in \{-1, 0, +1\}$.

16. For the unperturbed case $V = 0$, the eigenvectors and eigenenergies are related by

$$(\mathcal{H}_r + \mathcal{H}_a) |n, \sigma\rangle = E_{n, \sigma}^0 |n, \sigma\rangle , \quad (9.320)$$

where $n = 0, 1, 2, \dots$ is the quantum number of the harmonic oscillator, and $\sigma \in \{-1, +1\}$ is the quantum number associated with the two-level particle, and

$$E_{n, \sigma}^0 = \hbar \omega_r \left(n + \frac{1}{2} \right) + \sigma \frac{\hbar \omega_a}{2} . \quad (9.321)$$

- a) To second order in perturbation theorem [see Eq. (9.32)]

$$E_{n, \sigma} = E_{n, \sigma}^0 + \langle n, \sigma | V | n, \sigma \rangle + \sum_{n', \sigma' \neq n, \sigma} \frac{|\langle n', \sigma' | V | n, \sigma \rangle|^2}{E_{n, \sigma}^0 - E_{n', \sigma'}^0} . \quad (9.322)$$

Using

$$V |n, +\rangle = \hbar g a^\dagger |n, -\rangle = \hbar g \sqrt{n+1} |n+1, -\rangle , \quad (9.323)$$

$$V |n, -\rangle = \hbar g a |n, +\rangle = \hbar g \sqrt{n} |n-1, +\rangle , \quad (9.324)$$

one finds for $\sigma = +1$

$$\begin{aligned} E_{n, +1} &= \hbar \omega_r \left(n + \frac{1}{2} \right) + \frac{\hbar \omega_a}{2} + \frac{\hbar g^2 (n+1)}{\omega_a - \omega_r} \\ &= \hbar \left[\left(\omega_r + \frac{g^2}{\Delta} \right) \left(n + \frac{1}{2} \right) + \frac{\omega_a + \frac{g^2}{\Delta}}{2} \right] , \end{aligned} \quad (9.325)$$

and for $\sigma = -1$

$$\begin{aligned}
 E_{n,-1} &= \hbar\omega_r \left(n + \frac{1}{2} \right) - \frac{\hbar\omega_a}{2} - \frac{\hbar g^2 n}{\omega_a - \omega_r} \\
 &= \hbar \left[\left(\omega_r - \frac{g^2}{\Delta} \right) \left(n + \frac{1}{2} \right) + \frac{-\omega_a + \frac{g^2}{\Delta}}{2} \right],
 \end{aligned} \tag{9.326}$$

where

$$\Delta = \omega_a - \omega_r. \tag{9.327}$$

For the general case this can be written as

$$E_{n,\sigma} = \hbar \left[\left(\omega_r + \frac{g^2}{\Delta} \sigma \right) \left(n + \frac{1}{2} \right) + \frac{1}{2} \left(\sigma\omega_a + \frac{g^2}{\Delta} \right) \right]. \tag{9.328}$$

Thus, according to the above result (9.328), the energies of the states $(n, +1)$ and $(n + 1, -)$, which are degenerate for the case where $\omega_r = \omega_a$ and where $g = 0$, are given to second order in g by

$$E_{n,+1} = \hbar \left[\left(\omega_r + \frac{g^2}{\Delta} \right) (n + 1) + \frac{\Delta}{2} \right], \tag{9.329}$$

and

$$E_{n+1,-1} = \hbar \left[\left(\omega_r - \frac{g^2}{\Delta} \right) (n + 1) - \frac{\Delta}{2} \right]. \tag{9.330}$$

- b) In the degenerate case $\omega_r = \omega_a \equiv \omega$ the eigenenergies for the case $V = 0$ are given by

$$E_{n,\sigma}^0 = \hbar\omega \left(n + \frac{1}{2} + \frac{\sigma}{2} \right), \tag{9.331}$$

thus the pairs of states $|n, +\rangle$ and $|n + 1, -\rangle$ are degenerate. In the subset of such a pair the perturbation is given by

$$\begin{pmatrix} \langle n, + | V | n, + \rangle & \langle n, + | V | n + 1, - \rangle \\ \langle n + 1, - | V | n, + \rangle & \langle n + 1, - | V | n + 1, - \rangle \end{pmatrix} = \begin{pmatrix} 0 & \hbar g \sqrt{n + 1} \\ \hbar g \sqrt{n + 1} & 0 \end{pmatrix}, \tag{9.332}$$

thus to first order in g the eigenenergies are given by

$$E = \hbar [\omega (n + 1) \pm g \sqrt{n + 1}]. \tag{9.333}$$

- c) Using Eq. (2.182) one finds that (note that $\mathcal{S}^\dagger = -\mathcal{S}$)

$$\mathcal{H}' = \mathcal{H} + [L, \mathcal{H}] + \frac{1}{2!} [L, [L, \mathcal{H}]] + \dots, \tag{9.334}$$

where

$$L = \frac{g}{\Delta} (a\Sigma_+ - a^\dagger\Sigma_-) . \quad (9.335)$$

Using the commutation relations

$$[\Sigma_z, \Sigma_+] = 2\Sigma_+ , \quad (9.336)$$

$$[\Sigma_z, \Sigma_-] = -2\Sigma_- , \quad (9.337)$$

$$[\Sigma_+, \Sigma_-] = \Sigma_z , \quad (9.338)$$

$$[a, a^\dagger a] = a , \quad (9.339)$$

$$[a^\dagger, a^\dagger a] = -a^\dagger , \quad (9.340)$$

one finds that

$$[L, \mathcal{H}] = -\hbar g (a^\dagger\Sigma_- + a\Sigma_+) + 2\hbar \frac{g^2}{\Delta} \left(\frac{1 + \Sigma_z}{2} + a^\dagger a \Sigma_z \right) , \quad (9.341)$$

and thus

$$\begin{aligned} \mathcal{H}' &= \hbar \left(\omega_r + \frac{g^2}{\Delta} \Sigma_z \right) a^\dagger a + \frac{\hbar}{2} \left(\omega_a + \frac{g^2}{\Delta} \right) \Sigma_z \\ &\quad + \frac{\hbar \left(\omega_r + \frac{g^2}{\Delta} \right)}{2} + O \left(\left(\frac{g}{\Delta} \right)^3 \right) . \end{aligned} \quad (9.342)$$

Note that to second order in g/Δ the states $|n, \sigma\rangle$ are eigenvalues of \mathcal{H}' , and the following holds

$$\mathcal{H}' |n, \sigma\rangle = \tilde{E}_{n, \sigma} |n, \sigma\rangle , \quad (9.343)$$

where

$$E_{n, \sigma} = \hbar \left[\left(\omega_r + \frac{g^2}{\Delta} \sigma \right) \left(n + \frac{1}{2} \right) + \frac{1}{2} \left(\sigma \omega_a + \frac{g^2}{\Delta} \right) \right] . \quad (9.344)$$

The above result agrees with Eq. (9.328).

- d) Consider the pair of states $|n, +\rangle$ and $|n+1, -\rangle$. The following holds [see Eq. (9.79)]

$$\mathcal{H} |n, +\rangle = \hbar \omega_r (n+1) |n, +\rangle + \frac{\hbar \Delta}{2} |n, +\rangle + \hbar g \sqrt{n+1} |n+1, -\rangle , \quad (9.345)$$

and

$$\mathcal{H} |n+1, -\rangle = \hbar \omega_r (n+1) |n+1, -\rangle - \frac{\hbar \Delta}{2} |n+1, -\rangle + \hbar g \sqrt{n+1} |n, +\rangle , \quad (9.346)$$

where

$$\Delta = \omega_a - \omega_r , \quad (9.347)$$

or in a matrix form

$$\begin{aligned} & \mathcal{H} \begin{pmatrix} |n, +\rangle \\ |n+1, -\rangle \end{pmatrix} \\ &= \hbar \left[\omega_r (n+1) \begin{pmatrix} 1 & 0 \\ 0 & 1 \end{pmatrix} + \frac{\omega_n}{2} \begin{pmatrix} \cos \theta & \sin \theta \\ \sin \theta & -\cos \theta \end{pmatrix} \right] \begin{pmatrix} |n, +\rangle \\ |n+1, -\rangle \end{pmatrix}, \end{aligned} \quad (9.348)$$

where

$$\omega_n = \sqrt{\Delta^2 + 4g^2(n+1)}, \quad (9.349)$$

$$\tan \theta = \frac{2g\sqrt{n+1}}{\Delta}. \quad (9.350)$$

Thus, the states $|n_+\rangle$ and $|n_-\rangle$, which are given by [see Eqs. (6.301) and (6.302)]

$$|n_+\rangle = \cos \frac{\theta}{2} |n, +\rangle + \sin \frac{\theta}{2} |n+1, -\rangle, \quad (9.351)$$

$$|n_-\rangle = -\sin \frac{\theta}{2} |n, +\rangle + \cos \frac{\theta}{2} |n+1, -\rangle, \quad (9.352)$$

are eigenstates of \mathcal{H} and the following holds

$$\mathcal{H} |n_\pm\rangle = E_{n_\pm} |n_\pm\rangle, \quad (9.353)$$

where

$$\begin{aligned} E_{n_\pm} &= \hbar \left[\omega_r (n+1) \pm \frac{\omega_n}{2} \right] \\ &= \hbar \left[\omega_r (n+1) \pm \sqrt{\frac{\Delta^2}{4} + g^2(n+1)} \right]. \end{aligned} \quad (9.354)$$

The ground state is the state $|0, -\rangle$

$$\mathcal{H} |0, -\rangle = E_g |n, -\rangle, \quad (9.355)$$

and the ground state energy is

$$E_g = -\frac{\hbar\Delta}{2}. \quad (9.356)$$

e) The desired unitary operator U is required to satisfy [see Eq. (9.355)]

$$U |0, -\rangle = |0, -\rangle, \quad (9.357)$$

and [see Eqs. (9.351) and (9.352)]

$$U |n, +\rangle = |n_+\rangle = \cos \frac{\theta}{2} |n, +\rangle + \sin \frac{\theta}{2} |n+1, -\rangle, \quad (9.358)$$

$$U |n+1, -\rangle = |n_-\rangle = -\sin \frac{\theta}{2} |n, +\rangle + \cos \frac{\theta}{2} |n+1, -\rangle, \quad (9.359)$$

where

$$\tan \theta = \frac{2g\sqrt{n+1}}{\Delta}. \quad (9.360)$$

The required transformation can be constructed using the operators \mathcal{S} and \mathcal{N} , which are defined by

$$\mathcal{S} = a^\dagger \Sigma_- - a \Sigma_+, \quad (9.361)$$

and

$$\mathcal{N} = a^\dagger a + |+\rangle \langle +|. \quad (9.362)$$

The following holds

$$\mathcal{S} |0, -\rangle = 0, \quad (9.363)$$

$$\mathcal{S} |n, +\rangle = \sqrt{n+1} |n+1, -\rangle, \quad (9.364)$$

$$\mathcal{S} |n+1, -\rangle = -\sqrt{n+1} |n, +\rangle, \quad (9.365)$$

and

$$\mathcal{N} |n+1, -\rangle = (n+1) |n, -\rangle, \quad (9.366)$$

$$\mathcal{N} |n, +\rangle = (n+1) |n, +\rangle. \quad (9.367)$$

Thus, the operator \mathcal{I} , which is defined by

$$\mathcal{I} = \mathcal{N}^{-1/2} \mathcal{S}, \quad (9.368)$$

satisfies

$$\mathcal{I} |n, +\rangle = |n+1, -\rangle, \quad (9.369)$$

$$\mathcal{I} |n+1, -\rangle = -|n, +\rangle. \quad (9.370)$$

Therefore, Eqs. (9.351) and (9.352) can be rewritten as

$$|n_+\rangle = U |n, +\rangle, \quad (9.371)$$

$$|n_-\rangle = U |n+1, -\rangle, \quad (9.372)$$

where

$$U = \cos \frac{\theta}{2} + \sin \frac{\theta}{2} \mathcal{I}. \quad (9.373)$$

Furthermore, with the help of Eq. (9.360) one finds that [note that $\mathcal{I}^2 |n, +\rangle = -|n, +\rangle$ and $\mathcal{I}^2 |n+1, -\rangle = -|n+1, -\rangle$]

$$U = \exp \left(\frac{\mathcal{I}}{2} \tan^{-1} \frac{2g\mathcal{N}^{1/2}}{\Delta} \right). \quad (9.374)$$

To first order in g/Δ the following holds [compare with Eq. (9.86)]

$$U = e^{\frac{g}{\Delta} \mathcal{S}} + O \left(\left(\frac{g}{\Delta} \right)^3 \right). \quad (9.375)$$

f) With the help of Eqs. (2.182) and (9.374) one finds that

$$\mathcal{H}' = \mathcal{H} + [L, \mathcal{H}] + \frac{1}{2!} [L, [L, \mathcal{H}]] + \frac{1}{3!} [L, [L, [L, \mathcal{H}]]] + \dots, \quad (9.376)$$

where

$$L = -\mathcal{S}f(\mathcal{N}) , \quad (9.377)$$

and where the function f is given by

$$\begin{aligned} f(x) &= \frac{x^{-1/2}}{2} \tan^{-1} \frac{2gx^{1/2}}{\Delta} \\ &= \frac{g}{\Delta} - \frac{4x}{3} \left(\frac{g}{\Delta}\right)^3 + O\left(\left(\frac{g}{\Delta}\right)^5\right) . \end{aligned} \quad (9.378)$$

The following holds

$$f^2(x) = \left(\frac{g}{\Delta}\right)^2 - \frac{8x}{3} \left(\frac{g}{\Delta}\right)^4 + O\left(\left(\frac{g}{\Delta}\right)^6\right) , \quad (9.379)$$

and

$$f^3(x) = \left(\frac{g}{\Delta}\right)^3 + O\left(\left(\frac{g}{\Delta}\right)^5\right) . \quad (9.380)$$

Using the commutation relations

$$[a^\dagger \Sigma_- + a \Sigma_+, a^\dagger a] = -[a^\dagger \Sigma_- + a \Sigma_+, |+\rangle \langle +|] = -a^\dagger \Sigma_- + a \Sigma_+ , \quad (9.381)$$

one finds that

$$[\mathcal{H}, \mathcal{N}] = 0 ,$$

and using the commutation relations

$$[a^\dagger a, a^\dagger \Sigma_- - a \Sigma_+] = a^\dagger \Sigma_- + a \Sigma_+ , \quad (9.382)$$

$$\left[\frac{\Sigma_z}{2}, a^\dagger \Sigma_- - a \Sigma_+\right] = -a^\dagger \Sigma_- - a \Sigma_+ , \quad (9.383)$$

$$[a^\dagger \Sigma_- + a \Sigma_+, a^\dagger \Sigma_- - a \Sigma_+] = 1 + 2 \left(a^\dagger a + \frac{1}{2}\right) \Sigma_z , \quad (9.384)$$

one finds that

$$[\mathcal{H}, \mathcal{S}] = -\hbar\Delta (a^\dagger \Sigma_- + a \Sigma_+) + \hbar g \left[1 + 2 \left(a^\dagger a + \frac{1}{2}\right) \Sigma_z\right] . \quad (9.385)$$

Thus, the following holds

$$[L, \mathcal{H}] = [\mathcal{H}, \mathcal{S}] f(\mathcal{N}) , \quad (9.386)$$

and (note that $[\mathcal{S}, \mathcal{N}] = 0$ and $[[\mathcal{H}, \mathcal{S}], \mathcal{N}] = 0$)

$$[L, [L, \mathcal{H}]] = [[\mathcal{H}, \mathcal{S}], \mathcal{S}] f^2(\mathcal{N}) , \quad (9.387)$$

where

$$\begin{aligned}
 [[\mathcal{H}, \mathcal{S}], \mathcal{S}] &= -\hbar\Delta \left[1 + 2 \left(a^\dagger a + \frac{1}{2} \right) \Sigma_z \right] \\
 &- 4\hbar g \left(a^\dagger a + \frac{1}{2} \right) (a^\dagger \Sigma_- + a \Sigma_+) + 2\hbar g (a^\dagger \Sigma_- + a \Sigma_+) \Sigma_z,
 \end{aligned} \tag{9.388}$$

and therefore (note that $[[[\mathcal{H}, \mathcal{S}], \mathcal{S}], \mathcal{N}] = 0$)

$$\begin{aligned}
 &[L, [L, [L, \mathcal{H}]]] \\
 &= [[[\mathcal{H}, \mathcal{S}], \mathcal{S}] f^2(\mathcal{N}), \mathcal{S} f(\mathcal{N})] \\
 &= [[[\mathcal{H}, \mathcal{S}], \mathcal{S}], \mathcal{S}] f^3(\mathcal{N}),
 \end{aligned} \tag{9.389}$$

where

$$\begin{aligned}
 &[[[\mathcal{H}, \mathcal{S}], \mathcal{S}], \mathcal{S}] \\
 &= 4\hbar\Delta \left(a^\dagger a + \frac{1}{2} \right) (a^\dagger \Sigma_- + a \Sigma_+) - 2\hbar\Delta (a^\dagger \Sigma_- + a \Sigma_+) \Sigma_z \\
 &- 4\hbar g \left(a^\dagger a + \frac{1}{2} \right) \left[1 + 2 \left(a^\dagger a + \frac{1}{2} \right) \Sigma_z \right] \\
 &- 8\hbar g (a^\dagger \Sigma_- + a \Sigma_+)^2 \\
 &+ 2\hbar g \left[1 + 2 \left(a^\dagger a + \frac{1}{2} \right) \Sigma_z \right] \Sigma_z.
 \end{aligned} \tag{9.390}$$

By combining the above results one finds that

$$\begin{aligned}
 \hbar^{-1} \mathcal{H}' &= \left[\omega_r - \frac{4g^4}{3\Delta^3} + \xi \Sigma_z - \frac{4g^4}{3\Delta^3} a^\dagger a \Sigma_z \right] a^\dagger a \\
 &+ \frac{1}{2} (\omega_a + \xi) \Sigma_z + \frac{\omega_r}{2} + \frac{\xi}{2} \\
 &+ O\left(\left(\frac{g}{\Delta} \right)^5 \right),
 \end{aligned} \tag{9.391}$$

where

$$\xi = \frac{g^2}{\Delta} \left(1 - \frac{4g^2}{3\Delta^2} \right). \tag{9.392}$$

17. Using creation and annihilation operators one has

$$\mathcal{H}_0 = \frac{p_x^2 + p_y^2}{2m} + \frac{1}{2} m \omega^2 (x^2 + y^2) = \hbar\omega (N_x + N_y + 1), \tag{9.393}$$

where $N_x = a_x^\dagger a_x$, $N_y = a_y^\dagger a_y$, and

$$\begin{aligned}
 V &= \frac{\beta\omega}{\hbar} L_z^2 \\
 &= \frac{\beta\omega}{\hbar} (xp_y - yp_x)^2 \\
 &= \frac{\beta\omega}{\hbar} [i\hbar (a_x a_y^\dagger - a_x^\dagger a_y)]^2 \\
 &= -\beta\hbar\omega \left[(a_x^2 (a_y^\dagger)^2 + (a_x^\dagger)^2 a_y^2 - a_x a_x^\dagger a_y^\dagger a_y - a_x^\dagger a_x a_y a_y^\dagger) \right] \\
 &= -\beta\hbar\omega \left[a_x^2 (a_y^\dagger)^2 + (a_x^\dagger)^2 a_y^2 - (1 + N_x) N_y - N_x (1 + N_y) \right] .
 \end{aligned} \tag{9.394}$$

a) For the case $\beta = 0$ the ground state $|0, 0\rangle$ is nondegenerate and has energy $E_{0,0} = \hbar\omega$. Since $V|0, 0\rangle = 0$ one finds to second order in β

$$E_{0,0} = \hbar\omega + \langle 0, 0 | V | 0, 0 \rangle - \frac{1}{\hbar\omega} \sum_{n_x, n_y \neq 0, 0} \frac{|\langle n_x, n_y | V | 0, 0 \rangle|^2}{n_x + n_y} = \hbar\omega + O(\beta^3) . \tag{9.395}$$

b) For the case $\beta = 0$ the first excited state is doubly degenerate

$$\mathcal{H}_0 |1, 0\rangle = 2\hbar\omega |1, 0\rangle , \tag{9.396}$$

$$\mathcal{H}_0 |0, 1\rangle = 2\hbar\omega |0, 1\rangle . \tag{9.397}$$

The matrix of V in the basis $\{|1, 0\rangle, |0, 1\rangle\}$ is given by

$$\begin{aligned}
 &\begin{pmatrix} \langle 1, 0 | V | 1, 0 \rangle & \langle 1, 0 | V | 0, 1 \rangle \\ \langle 0, 1 | V | 1, 0 \rangle & \langle 0, 1 | V | 0, 1 \rangle \end{pmatrix} \\
 &= \beta\hbar\omega \begin{pmatrix} \langle 1, 0 | [(1 + N_x) N_y + N_x (1 + N_y)] | 1, 0 \rangle & 0 \\ 0 & \langle 0, 1 | [(1 + N_x) N_y + N_x (1 + N_y)] | 0, 1 \rangle \end{pmatrix} \\
 &= \beta\hbar\omega \begin{pmatrix} 1 & 0 \\ 0 & 1 \end{pmatrix} .
 \end{aligned} \tag{9.398}$$

Thus to first order in β the first excited state remains doubly degenerate with energy $2\hbar\omega(1 + \beta)$. Note - The exact solution can be found using the transformation

$$a_d = \frac{1}{\sqrt{2}} (a_x - ia_y) , \tag{9.399}$$

$$a_g = \frac{1}{\sqrt{2}} (a_x + ia_y) . \tag{9.400}$$

The following holds

$$\begin{aligned}
 [a_d, a_d^\dagger] &= [a_g, a_g^\dagger] = 1 , \\
 a_d^\dagger a_d + a_g^\dagger a_g &= \frac{1}{2} (a_x^\dagger + ia_y^\dagger) (a_x - ia_y) + \frac{1}{2} (a_x^\dagger - ia_y^\dagger) (a_x + ia_y) \\
 &= a_x^\dagger a_x + a_y^\dagger a_y ,
 \end{aligned} \tag{9.401}$$

and

$$\begin{aligned} a_d^\dagger a_d - a_g^\dagger a_g &= \frac{1}{2} (a_x^\dagger + i a_y^\dagger) (a_x - i a_y) - \frac{1}{2} (a_x^\dagger - i a_y^\dagger) (a_x + i a_y) \\ &= i (a_x a_y^\dagger - a_x^\dagger a_y) , \end{aligned} \quad (9.402)$$

thus

$$\mathcal{H}_0 = \hbar\omega (N_d + N_g + 1) , \quad (9.403)$$

$$V = \beta \hbar\omega (N_d - N_g)^2 , \quad (9.404)$$

and the exact eigen vectors and eigenenergies are given by

$$(\mathcal{H}_0 + V) |n_d, n_g\rangle = \hbar\omega [n_d + n_g + 1 + \beta (n_d - n_g)^2] |n_d, n_g\rangle . \quad (9.405)$$

18. For $V_0 = 0$ the wavefunctions $\psi_n^{(0)}(x)$ are given by

$$\psi_n^{(0)}(x) = \langle x' | n \rangle = \sqrt{\frac{2}{l}} \sin \frac{n\pi x'}{l} , \quad (9.406)$$

and the corresponding eigenenergies are

$$E_n^{(0)} = \frac{\hbar^2 \pi^2 n^2}{2ml^2} . \quad (9.407)$$

The matrix elements of the perturbation are given by

$$\langle n | V | m \rangle = \frac{2V_0}{l} \int_0^l \sin \frac{n\pi x}{l} \sin \frac{m\pi x}{l} \sin \frac{2\pi x}{l} dx . \quad (9.408)$$

For the diagonal case $n = m$

$$\langle n | V | n \rangle = \frac{2V_0}{l} \int_0^l \sin^2 \frac{n\pi x}{l} \sin \frac{2\pi x}{l} dx \quad (9.409)$$

$$= \frac{2V_0}{l} \int_{-l/2}^{l/2} \sin^2 \left(\frac{n\pi y}{l} + \frac{n\pi}{2} \right) \sin \left(\frac{2\pi y}{l} + \pi \right) dy \quad (9.410)$$

$$= -\frac{2V_0}{l} \int_{-l/2}^{l/2} \frac{1 - \cos \left(\frac{2n\pi y}{l} + n\pi \right)}{2} \sin \frac{2\pi y}{l} dy \quad (9.411)$$

$$= 0 , \quad (9.412)$$

$$(9.413)$$

since the integrand is clearly an odd function of y . Thus to first order in V_0 the energies are unchanged

$$E_n = \frac{\hbar^2 \pi^2 n^2}{2ml^2} + O(V_0^2) . \quad (9.414)$$

19. For the case $\varepsilon = 0$ the exact wave functions are given by

$$\psi_n^{(0)}(x) = \sqrt{\frac{2}{L}} \sin\left(\frac{n\pi x}{L}\right) , \quad (9.415)$$

and the corresponding eigenenergies are

$$E_n^{(0)} = \frac{\hbar^2 \pi^2 n^2}{2mL^2} , \quad (9.416)$$

where n is integer. To first order in ε the energy of the ground state $n = 1$ is given by

$$\begin{aligned} E_1 &= E_1^{(0)} + \frac{\varepsilon}{L} \int_0^L dx \left(\psi_1^{(0)}(x)\right)^2 x + O(\varepsilon^2) \\ &= E_1^{(0)} + \frac{2\varepsilon}{L^2} \int_0^L dx \sin^2\left(\frac{\pi x}{L}\right) x + O(\varepsilon^2) \\ &= E_1^{(0)} + \frac{\varepsilon}{2} + O(\varepsilon^2) \end{aligned} \quad (9.417)$$

20. For the case $\lambda = 0$ the exact wave functions of the eigenstates are given by

$$\psi_{n_x, n_y}^{(0)}(x, y) = \frac{2}{l} \sin \frac{n_x \pi x}{l} \sin \frac{n_y \pi y}{l} , \quad (9.418)$$

and the corresponding eigenenergies are

$$E_{n_x, n_y}^{(0)} = \frac{\hbar^2 \pi^2 (n_x^2 + n_y^2)}{2ml^2} , \quad (9.419)$$

where n_x and n_y are non-zero integers.

a) The ground state is non degenerate thus to 1st order the energy is given by

$$\begin{aligned} E_0 &= E_{1,1}^{(0)} + \int_0^l \int_0^l \left(\psi_{1,1}^{(0)}\right)^2 W \, dx dy \\ &= \frac{\hbar^2 \pi^2}{ml^2} \\ &\quad + \frac{\hbar^2 \pi^2}{ml^2} 4\lambda \int_0^l \int_0^l \sin^2 \frac{\pi x}{l} \sin^2 \frac{\pi y}{l} \delta(x - l_x) \delta(y - l_y) \, dx dy \\ &= \frac{\hbar^2 \pi^2}{ml^2} \left(1 + 4\lambda \sin^2 \frac{\pi l_x}{l} \sin^2 \frac{\pi l_y}{l} \right) . \end{aligned} \quad (9.420)$$

b) The first excited state is doubly degenerate. The matrix of the perturbation W in the eigen subspace is given by

$$\begin{aligned}
 W &\doteq \begin{pmatrix} \langle 2, 1 | W | 2, 1 \rangle & \langle 2, 1 | W | 1, 2 \rangle \\ \langle 1, 2 | W | 2, 1 \rangle & \langle 1, 2 | W | 1, 2 \rangle \end{pmatrix} \\
 &= 4\lambda \frac{\hbar^2 \pi^2}{ml^2} \begin{pmatrix} \sin^2 \frac{2\pi l_x}{l} \sin^2 \frac{\pi l_y}{l} & \sin \frac{2\pi l_x}{l} \sin \frac{\pi l_x}{l} \sin \frac{\pi l_y}{l} \sin \frac{2\pi l_y}{l} \\ \sin \frac{\pi l_x}{l} \sin \frac{2\pi l_x}{l} \sin \frac{2\pi l_y}{l} \sin \frac{\pi l_y}{l} & \sin^2 \frac{\pi l_x}{l} \sin^2 \frac{2\pi l_y}{l} \end{pmatrix} \\
 &= 4\lambda \frac{\hbar^2 \pi^2}{ml^2} \begin{pmatrix} 4 \sin^2 \frac{\pi l_x}{l} \cos^2 \frac{\pi l_x}{l} \sin^2 \frac{\pi l_y}{l} & 4 \cos \frac{\pi l_x}{l} \sin^2 \frac{\pi l_x}{l} \cos \frac{\pi l_y}{l} \sin^2 \frac{\pi l_y}{l} \\ 4 \cos \frac{\pi l_x}{l} \sin^2 \frac{\pi l_x}{l} \cos \frac{\pi l_y}{l} \sin^2 \frac{\pi l_y}{l} & 4 \sin^2 \frac{\pi l_x}{l} \sin^2 \frac{\pi l_y}{l} \cos^2 \frac{\pi l_y}{l} \end{pmatrix} \\
 &= \frac{16\lambda \hbar^2 \pi^2 \sin^2 \frac{\pi l_x}{l} \sin^2 \frac{\pi l_y}{l}}{ml^2} \begin{pmatrix} \cos^2 \frac{\pi l_x}{l} & \cos \frac{\pi l_x}{l} \cos \frac{\pi l_y}{l} \\ \cos \frac{\pi l_x}{l} \cos \frac{\pi l_y}{l} & \cos^2 \frac{\pi l_y}{l} \end{pmatrix}.
 \end{aligned} \tag{9.421}$$

The eigenvalues of W are

$$w_1 = 0, \tag{9.422}$$

and

$$w_2 = \frac{16\lambda \hbar^2 \pi^2 \sin^2 \frac{\pi l_x}{l} \sin^2 \frac{\pi l_y}{l} (\cos^2 \frac{\pi l_x}{l} + \cos^2 \frac{\pi l_y}{l})}{ml^2}. \tag{9.423}$$

21. The unperturbed Hamiltonian ($\lambda = 0$) can be written as

$$\begin{aligned}
 \mathcal{H} &= \frac{\mathbf{L}^2 - L_z^2}{2I_{xy}} + \frac{L_z^2}{2I_z} \\
 &= \frac{\mathbf{L}^2}{2I_{xy}} + \left(\frac{1}{2I_z} - \frac{1}{2I_{xy}} \right) L_z^2,
 \end{aligned} \tag{9.424}$$

thus the states $|l, m\rangle$ (the standard eigenstates of \mathbf{L}^2 and L_z) are eigenstates of \mathcal{H} and the following holds

$$\mathcal{H} |l, m\rangle = E_{l,m} |l, m\rangle, \tag{9.425}$$

where

$$E_{l,m} = \hbar^2 \left[\frac{l(l+1)}{2I_{xy}} + \left(\frac{1}{2I_z} - \frac{1}{2I_{xy}} \right) m^2 \right]. \tag{9.426}$$

Since the unperturbed Hamiltonian is positive-definite, it is clear that the state $|l = 0, m = 0\rangle$ is the (nondegenerate) ground state of the system since its energy vanishes $E_{0,0} = 0$. Using

$$L_x = \frac{L_+ + L_-}{2}, \tag{9.427}$$

$$L_y = \frac{L_+ - L_-}{2i}, \tag{9.428}$$

one finds that the perturbation term V can be written as

$$V = \lambda \frac{L_+^2 + L_-^2}{4I_{xy}} . \quad (9.429)$$

To second order in λ the energy of the ground state is found using Eq. (9.32)

$$E_0 = E_{0,0} + \langle 0,0 | V | 0,0 \rangle + \sum_{l',m' \neq 0,0} \frac{|\langle l',m' | V | 0,0 \rangle|^2}{E_{0,0} - E_{l',m'}} + O(\lambda^3) . \quad (9.430)$$

Using the relations

$$L_+ |l, m\rangle = \sqrt{l(l+1) - m(m+1)} \hbar |l, m+1\rangle , \quad (9.431)$$

$$L_- |l, m\rangle = \sqrt{l(l+1) - m(m-1)} \hbar |l, m-1\rangle , \quad (9.432)$$

it is easy to see that all terms to second order in λ vanish, thus

$$E_0 = 0 + O(\lambda^3) . \quad (9.433)$$

22. The Hamiltonian can be written as

$$\mathcal{H} = \mathcal{H}_1 + \mathcal{H}_2 + V , \quad (9.434)$$

where

$$\mathcal{H}_1 = \frac{p_1^2}{2m} - \alpha \delta(x_1) , \quad (9.435)$$

$$\mathcal{H}_2 = \frac{p_2^2}{2m} - \alpha \delta(x_2) , \quad (9.436)$$

and

$$V = \lambda \delta(x_1 - x_2) . \quad (9.437)$$

First consider \mathcal{H}_1 only. A wavefunction $\psi^{(1)}(x_1)$ of an eigenstate of \mathcal{H}_1 must satisfy the following Schrödinger equation

$$\left[\frac{d^2}{dx_1^2} + \frac{2m}{\hbar^2} (E + \alpha \delta(x_1)) \right] \psi^{(1)}(x_1) = 0 . \quad (9.438)$$

Integrating around $x_1 = 0$ yields the condition

$$\frac{d\psi^{(1)}(0^+)}{dx_1} - \frac{d\psi^{(1)}(0^-)}{dx_1} + \frac{2m\alpha}{\hbar^2} \psi^{(1)}(0) = 0 . \quad (9.439)$$

Requiring also that the wavefunction is normalizable leads to

$$\psi^{(1)}(x_1) = \sqrt{\frac{m\alpha}{\hbar^2}} \exp\left(-\frac{m\alpha}{\hbar^2} |x_1|\right) .$$

The corresponding eigenenergy is

$$E_0^{(1)} = -\frac{m\alpha^2}{2\hbar^2} .$$

The ground state of \mathcal{H}_2 can be found in a similar way. Thus, the normalized wavefunction of the only bound state of $\mathcal{H}_1 + \mathcal{H}_2$, which is obviously the ground state, is given by

$$\psi_0(x_1, x_2) = \frac{m\alpha}{\hbar^2} \exp\left(-\frac{m\alpha}{\hbar^2} |x_1|\right) \exp\left(-\frac{m\alpha}{\hbar^2} |x_2|\right) , \quad (9.440)$$

and the corresponding energy is given by

$$E_0 = -\frac{m\alpha^2}{\hbar^2} . \quad (9.441)$$

Therefore, to first order in λ the energy of the ground state of \mathcal{H} is given by Eq. (9.32)

$$\begin{aligned} E_{\text{gs}} &= -\frac{m\alpha^2}{\hbar^2} \\ &\quad + \lambda \int_{-\infty}^{\infty} dx_1 \int_{-\infty}^{\infty} dx_2 \psi_0^*(x_1, x_2) \delta(x_1 - x_2) \psi_0(x_1, x_2) + O(\lambda^2) \\ &= -\frac{m\alpha^2}{\hbar^2} + \lambda \left(\frac{m\alpha}{\hbar^2}\right)^2 \int_{-\infty}^{\infty} dx_1 \exp\left(-\frac{4m\alpha}{\hbar^2} |x_1|\right) + O(\lambda^2) \\ &= -\frac{m\alpha^2}{\hbar^2} + \frac{\lambda m\alpha}{2\hbar^2} + O(\lambda^2) . \end{aligned} \quad (9.442)$$

23. Substituting the expansions

$$|n\rangle = |n_0\rangle + \Omega |n_1\rangle + \Omega^2 |n_2\rangle + O(\Omega^3) , \quad (9.443)$$

and

$$\lambda = \lambda_{n_0} + \Omega \lambda_{n_1} + \Omega^2 \lambda_{n_2} + O(\Omega^3) , \quad (9.444)$$

into Eq. (9.102) and collecting terms having the same order in Ω (up to second order) yield

$$(D - \lambda_{n_0}) |n_0\rangle = 0 , \quad (9.445)$$

$$(D - \lambda_{n_0}) |n_1\rangle + (V - \lambda_{n_1}) |n_0\rangle = 0 , \quad (9.446)$$

$$(D - \lambda_{n_0}) |n_2\rangle + (V - \lambda_{n_1}) |n_1\rangle - \lambda_{n_2} |n_0\rangle = 0 . \quad (9.447)$$

We further require normalization

$$\langle n|n \rangle = 1 , \quad (9.448)$$

and choose the phase of $\langle n_0|n \rangle$ such that

$$\langle n_0|n \rangle \in \mathcal{R} . \quad (9.449)$$

Expressing the normalization condition using Eq. (9.443) and collecting terms having the same order in Ω yield

$$\langle n_0|n_0 \rangle = 1 , \quad (9.450)$$

$$\langle n_0|n_1 \rangle + \langle n_1|n_0 \rangle = 0 , \quad (9.451)$$

$$\langle n_0|n_2 \rangle + \langle n_2|n_0 \rangle + \langle n_1|n_1 \rangle = 0 . \quad (9.452)$$

These results together with Eq. (9.449) yield

$$\langle n_0|n_1 \rangle = \langle n_1|n_0 \rangle = 0 , \quad (9.453)$$

$$\langle n_0|n_2 \rangle = \langle n_2|n_0 \rangle = -\frac{1}{2} \langle n_1|n_1 \rangle . \quad (9.454)$$

Multiplying Eq. (9.446) by $\langle m_0|$ yields

$$\lambda_{n1} \langle m_0|n_0 \rangle = (\lambda_{m0} - \lambda_{n0}) \langle m_0|n_1 \rangle + \langle m_0|V|n_0 \rangle , \quad (9.455)$$

thus for $m = n$

$$\lambda_{n1} = \langle n_0|V|n_0 \rangle . \quad (9.456)$$

Using this result for $m \neq n$ yields

$$\langle m_0|n_1 \rangle = \frac{\langle m_0|V|n_0 \rangle}{\lambda_{n0} - \lambda_{m0}} , \quad (9.457)$$

thus with the help of Eq. (9.101) one has

$$|n_1 \rangle = \sum_m \frac{\langle m_0|V|n_0 \rangle}{\lambda_{n0} - \lambda_{m0}} |m_0 \rangle . \quad (9.458)$$

Multiplying Eq. (9.447) by $\langle n_0|$ yields

$$\lambda_{n2} = \langle n_0|V|n_1 \rangle - \lambda_{n1} \langle n_0|n_1 \rangle , \quad (9.459)$$

or using Eq. (9.458)

$$\lambda_{n2} = \sum_m \frac{\langle n_0|V|m_0 \rangle \langle m_0|V|n_0 \rangle}{\lambda_{n0} - \lambda_{m0}} . \quad (9.460)$$

Thus, using this result together with Eq. (9.456) one finds

$$\begin{aligned} \lambda &= \lambda_{n0} + \Omega \langle n_0|V|n_0 \rangle \\ &+ \Omega^2 \sum_m \frac{\langle n_0|V|m_0 \rangle \langle m_0|V|n_0 \rangle}{\lambda_{n0} - \lambda_{m0}} + O(\Omega^3) . \end{aligned} \quad (9.461)$$

24. The condition [9.108] together with Eq. (9.104) can be used to evaluate the matrix elements of L

$$\langle k | L | k' \rangle = \lambda \frac{\langle k | \tilde{V} | k' \rangle}{E_k - E_{k'}}. \quad (9.462)$$

With the help of Eq. (2.182) one finds that

$$\mathcal{H}_R = \mathcal{H}_0 + \lambda \tilde{V} + [L, \mathcal{H}_0] + \left[L, \lambda \tilde{V} \right] + \frac{1}{2!} \left[L, \left[L, \mathcal{H}_0 + \lambda \tilde{V} \right] \right] + \dots \quad (9.463)$$

Thus, for the case where condition (9.108) is satisfied the following holds [note that according to Eq. (9.462) $L = O(\lambda)$]

$$\begin{aligned} \mathcal{H}_R &= \mathcal{H}_0 + \left[L, \lambda \tilde{V} \right] + \frac{1}{2!} [L, [L, \mathcal{H}_0]] + O(\lambda^3) \\ &= \mathcal{H}_0 + \frac{1}{2} \left[L, \lambda \tilde{V} \right] + O(\lambda^3) \end{aligned} \quad (9.464)$$

where Eq. (9.108) has been employed in the last step.

- a) The last result together with Eq. (9.462) and the closure relation $1 = \sum_{k''} |k''\rangle \langle k''|$ [see Eq. (2.23)] lead to

$$\begin{aligned} \langle k | \mathcal{H}_R | k' \rangle &= \langle k | \mathcal{H}_0 | k' \rangle + \frac{1}{2} \langle k | \left[L, \lambda \tilde{V} \right] | k' \rangle + O(\lambda^3) \\ &= E_k \delta_{k,k'} + \frac{\lambda^2 \sum_{k''} \langle k | \tilde{V} | k'' \rangle \langle k'' | \tilde{V} | k' \rangle \left(\frac{1}{E_k - E_{k''}} - \frac{1}{E_{k''} - E_{k'}} \right)}{2} + O(\lambda^3) \end{aligned} \quad (9.465)$$

- b) For the current case Eq. (9.107) yields

$$\begin{aligned} \langle k'_S k'_F | \mathcal{H}_R | k''_S k''_F \rangle &= E_{k'_S} \delta_{k'_S, k''_S} + E_{k'_F} \delta_{k'_F, k''_F} \\ &+ \frac{\lambda^2}{2} \sum_{k'''_S, k'''_F} \langle k'_S k'_F | \tilde{V} | k'''_S k'''_F \rangle \langle k'''_S k'''_F | \tilde{V} | k''_S k''_F \rangle \\ &\times \left(\frac{1}{E_{k'_S} + E_{k'_F} - E_{k'''_S} - E_{k'''_F}} - \frac{1}{E_{k'''_S} + E_{k'''_F} - E_{k''_S} - E_{k''_F}} \right) \end{aligned} \quad (9.466)$$

Disregarding the energy spacing terms corresponding to the slow subsystem $E_{k'_S} - E_{k'''_S}$ and $E_{k'_F} - E_{k'''_F}$ leads to

$$\begin{aligned}
 \langle k'_S k'_F | \mathcal{H}_R | k''_S k''_F \rangle &= E_{k'_S} \delta_{k'_S, k''_S} + E_{k'_F} \delta_{k'_F, k''_F} \\
 &+ \frac{\lambda^2}{2} \sum_{k'''_S, k'''_F} \langle k'_S k'_F | \tilde{V} | k'''_S k'''_F \rangle \langle k'''_S k'''_F | \tilde{V} | k''_S k''_F \rangle \\
 &\times \left(\frac{1}{E_{k'_F} - E_{k'''_F}} - \frac{1}{E_{k'''_F} - E_{k''_F}} \right),
 \end{aligned} \tag{9.467}$$

hence for $k'_F = k''_F = k_F$

$$\begin{aligned}
 \langle k'_S k_F | \mathcal{H}_R | k''_S k_F \rangle &= E_{k'_S} \delta_{k'_S, k''_S} + E_{k_F} \\
 &+ \lambda^2 \sum_{k'''_F} \frac{\langle k'_S k_F | \tilde{V} \left(\sum_{k'''_S} |k'''_S k'''_F\rangle \langle k'''_S k'''_F| \right) \tilde{V} | k''_S k_F \rangle}{E_{k_F} - E_{k'''_F}}.
 \end{aligned} \tag{9.468}$$

Thus the effective Hamiltonian $\mathcal{H}_{R,\text{eff}}^{(k_F)}$ corresponding to the case where the fast subsystem occupies the state $|k_F\rangle$ is given by (the constant term E_{k_F} is disregarded)

$$\mathcal{H}_{R,\text{eff}}^{(k_F)} = \mathcal{H}_S + \lambda^2 \sum_{k'''_F} \frac{P^{(k_F)} \tilde{V} |k'''_F\rangle \langle k'''_F| \tilde{V} P^{(k_F)}}{E_{k_F} - E_{k'''_F}}, \tag{9.469}$$

where the projection $P^{(k_F)}$ corresponding to the state $|k_F\rangle$ of the fast subsystem is given by

$$P^{(k_F)} = \sum_{k'_S} |k'_S k_F\rangle \langle k'_S k_F|. \tag{9.470}$$

25. The matrix H_0 has a nondegenerate eigenvalue 0, and a triply degenerate eigenvalue $2E$ [see Eq. (9.115)]. As can be seen from Eq. (9.116), the perturbation $\lambda\tilde{V}$ has no effect to first order in λ [see Eq. (9.38), and recall that Eq. (9.32) is inapplicable for the degenerate eigenvalue $2E$]. For this case the second order in λ contribution can be found using the Schrieffer-Wolff transformation. The transformed matrix, which is denoted by H_R , is found using Eq. (9.107) to be given in a block form by

$$H_R = H_0 + \left(\begin{array}{c|c} -\frac{\lambda^2(|\alpha|^2+|\beta|^2+|\gamma|^2)}{2E} & 0 \\ \hline 0 & V_D \end{array} \right), \tag{9.471}$$

where the 3×3 block V_D is given by

$$V_D = \frac{\lambda^2}{2E} \begin{pmatrix} \alpha^* \alpha & \alpha^* \beta & \alpha^* \gamma \\ \beta^* \alpha & \beta^* \beta & \beta^* \gamma \\ \gamma^* \alpha & \gamma^* \beta & \gamma^* \gamma \end{pmatrix}. \tag{9.472}$$

Note that

$$\begin{pmatrix} \alpha^* \alpha & \alpha^* \beta & \alpha^* \gamma \\ \beta^* \alpha & \beta^* \beta & \beta^* \gamma \\ \gamma^* \alpha & \gamma^* \beta & \gamma^* \gamma \end{pmatrix} = \begin{pmatrix} \alpha^* \\ \beta^* \\ \gamma^* \end{pmatrix} (\alpha \ \beta \ \gamma) , \quad (9.473)$$

thus the eigenvalues of V_D are $(\lambda^2 / (2E)) (|\alpha|^2 + |\beta|^2 + |\gamma|^2)$ and 0 (doubly degenerate). Hence, to second order in λ the eigenvalues of H are E_1 , E_2 (doubly degenerate) and E_3 , where

$$E_1 = -\frac{\lambda^2 (|\alpha|^2 + |\beta|^2 + |\gamma|^2)}{2E} + O(\lambda^3) , \quad (9.474)$$

$$E_2 = 2E + O(\lambda^3) , \quad (9.475)$$

$$E_3 = 2E + \frac{\lambda^2 (|\alpha|^2 + |\beta|^2 + |\gamma|^2)}{2E} + O(\lambda^3) . \quad (9.476)$$

For comparison, the exact eigenvalues of H are given by (E_2 is doubly degenerate)

$$E_1 = E - \sqrt{E^2 + \lambda^2 (|\alpha|^2 + |\beta|^2 + |\gamma|^2)} , \quad (9.477)$$

$$E_2 = 2E , \quad (9.478)$$

$$E_3 = E + \sqrt{E^2 + \lambda^2 (|\alpha|^2 + |\beta|^2 + |\gamma|^2)} . \quad (9.479)$$

26. Consider the Hamiltonian

$$\mathcal{H} = \frac{\mathbf{p}^2}{2\mu} - \frac{(1 + \lambda) e^2}{r} , \quad (9.480)$$

where μ is the reduced mass and e is the electron charge. The parameter λ is a positive constant. The exact eigenenergies are given by Eq. (7.84)

$$E_n = -\frac{\mu (1 + \lambda)^2 e^4}{2\hbar^2 n^2} . \quad (9.481)$$

On the other hand, perturbation theory yields the following expansion [see Eq. (9.32)]

$$E_n = -\frac{\mu e^4}{2\hbar^2 n^2} - \lambda \langle nlm | \frac{e^2}{r} | nlm \rangle + O(\lambda^2) . \quad (9.482)$$

By comparing the above results for E_n one finds that

$$-\langle nlm | \frac{e^2}{r} | nlm \rangle = -2 \frac{\mu e^4}{2\hbar^2 n^2} , \quad (9.483)$$

thus (recall that $V = -e^2/r$)

$$\langle nlm|V|nlm\rangle = -2\frac{\mu e^4}{2\hbar^2 n^2}, \quad (9.484)$$

and (recall that $T + V = \mathcal{H}$)

$$\langle nlm|T|nlm\rangle = \frac{\mu e^4}{2\hbar^2 n^2}. \quad (9.485)$$

27. The energy eigenvalues E_{kl} of the radial equation of the hydrogen atom, which is given by [see Eq. (7.61)]

$$\left(\frac{-\hbar^2}{2\mu} \frac{d^2}{dr^2} - \frac{e^2}{r} + \frac{l(l+1)\hbar^2}{2\mu r^2} \right) u_{kl}(r) = E_{kl} u_{kl}(r), \quad (9.486)$$

where μ is the reduced mass and e is the electron charge, are [see Eq. (7.78)]

$$E_{kl} = -\frac{\mu e^4}{2\hbar^2 (k+l)^2}, \quad (9.487)$$

where $k = 1, 2, 3, \dots$. The quantum number l can formally be treated as a real number, which is not restricted to take integer values only. Consider the case where the integer l is replaced by $l + \epsilon$, where $0 \leq \epsilon \ll 1$. While the exact eigenenergies can still be evaluated by Eq. (7.78)

$$E_{kl} = -\frac{\mu e^4}{2\hbar^2 (k+l+\epsilon)^2}, \quad (9.488)$$

perturbation theory yields the following expansion [see Eq. (9.32)]

$$E_{kl} = -\frac{\mu e^4}{2\hbar^2 (k+l)^2} + \langle klm|V_H|klm\rangle + \dots, \quad (9.489)$$

where the perturbation V_H is given by

$$\begin{aligned} V_H &= \frac{[(l+\epsilon)(l+\epsilon+1) - l(l+1)]\hbar^2}{2\mu r^2} \\ &= \frac{(2l+1)\epsilon\hbar^2}{2\mu r^2} + O(\epsilon^2), \end{aligned} \quad (9.490)$$

By comparing both results for E_{kl} one finds that

$$\langle klm|r^{-2}|klm\rangle = \frac{2\mu^2 e^4}{\hbar^4 (2l+1)(k+l)^3}, \quad (9.491)$$

or in terms of the quantum number $n = k + l$

$$\langle nlm | r^{-2} | nlm \rangle = \frac{2}{a_0^2 (2l+1) n^3}, \quad (9.492)$$

where

$$a_0 = \frac{\hbar^2}{\mu e^2}. \quad (9.493)$$

10. Time-Dependent Perturbation Theory

Recall that the time evolution of a state vector $|\alpha\rangle$ is governed by the Schrödinger equation (4.1)

$$i\hbar \frac{d|\alpha\rangle}{dt} = \mathcal{H}|\alpha\rangle , \quad (10.1)$$

where the Hermitian operator $\mathcal{H} = \mathcal{H}^\dagger$ is the Hamiltonian of the system. The time evolution operator $u(t, t_0)$ [see Eq. (4.4)] relates the state vector $|\alpha(t_0)\rangle$ at time t_0 with its value $|\alpha(t)\rangle$ at time t

$$|\alpha(t)\rangle = u(t, t_0) |\alpha(t_0)\rangle . \quad (10.2)$$

As we have seen in chapter 4, when the Hamiltonian is time independent $u(t, t_0)$ is given by

$$u(t, t_0) = \exp\left(-\frac{i(t-t_0)}{\hbar}\mathcal{H}\right) . \quad (10.3)$$

In this chapter we consider the more general case where \mathcal{H} is allowed to vary in time. We first derive a formal expression for the time evolution operator $u(t, t_0)$ applicable for general \mathcal{H} . Then we present the perturbation theory expansion of the time evolution operator, and discuss approximation schemes to evaluate $u(t, t_0)$.

10.1 Time Evolution

Dividing the time interval (t_0, t) into N sections of equal duration allows expressing the time evolution operator as

$$u(t, t_0) = \prod_{n=1}^N u(t_n, t_{n-1}) , \quad (10.4)$$

where

$$t_n = t_0 + n\epsilon , \quad (10.5)$$

and where

$$\epsilon = \frac{t - t_0}{N} . \quad (10.6)$$

Furthermore, according to the Schrödinger equation (4.7), the following holds

$$u(t_{n-1} + \epsilon, t_{n-1}) = 1 - \frac{i\epsilon}{\hbar} \mathcal{H}(t_n) + O(\epsilon^2) . \quad (10.7)$$

In the limit where $N \rightarrow \infty$ higher than first order terms in ϵ , i.e. $O(\epsilon^2)$ terms, are not expected to contribute, thus the time evolution operator can be expressed as

$$u(t, t_0) = \lim_{N \rightarrow \infty} \prod_{n=1}^N \left(1 - \frac{i\epsilon}{\hbar} \mathcal{H}(t_n) \right) . \quad (10.8)$$

10.2 Perturbation Expansion

Consider the case where

$$\mathcal{H} = \mathcal{H}_0 + \lambda \mathcal{H}_1 , \quad (10.9)$$

where λ is real. The perturbation expansion expresses the time evolution operator $u(t, t_0)$ of the full Hamiltonian \mathcal{H} as

$$u(t, t_0) = u_0(t, t_0) + \lambda u_1(t, t_0) + \lambda^2 u_2(t, t_0) + O(\lambda^3) , \quad (10.10)$$

where $u_0(t, t_0)$ is the time evolution of the Hamiltonian \mathcal{H}_0 . Such an expansion can be very useful for cases where $u_0(t, t_0)$ can be exactly calculated and where the parameter λ is small, i.e. $|\lambda| \ll 1$. For such cases only low order terms in this expansion are needed for approximately evaluating $u(t, t_0)$.

By employing Eq. (10.8)

$$u(t, t_0) = \lim_{N \rightarrow \infty} \prod_{n=1}^N \left[1 - \frac{i\epsilon}{\hbar} (\mathcal{H}_0(t_n) + \lambda \mathcal{H}_1(t_n)) \right] , \quad (10.11)$$

one easily obtains the terms u_0 , u_1 and u_2

$$u_0(t, t_0) = \lim_{N \rightarrow \infty} \prod_{n=1}^N \left(1 - \frac{i\epsilon}{\hbar} \mathcal{H}_0(t_n) \right) , \quad (10.12)$$

$$\begin{aligned} u_1(t, t_0) &= - \lim_{N \rightarrow \infty} \sum_{n=1}^N \frac{i\epsilon}{\hbar} u_0(t, t_n) \mathcal{H}_1(t_n) u_0(t_n, t_0) \\ &= - \frac{i}{\hbar} \int_{t_0}^t dt' u_0(t, t') \mathcal{H}_1(t') u_0(t', t_0) , \end{aligned} \quad (10.13)$$

and

$$\begin{aligned}
 u_2(t, t_0) &= - \lim_{N \rightarrow \infty} \sum_{n=1}^{N-1} \sum_{m=n+1}^N \left(\frac{\epsilon}{\hbar} \right)^2 \\
 &\quad \times u_0(t, t_n) \mathcal{H}_1(t_n) u_0(t_n, t_m) \mathcal{H}_1(t_m) u_0(t_m, t_0) \\
 &= - \frac{1}{\hbar^2} \int_{t_0}^t dt' \int_{t_0}^{t'} dt'' \\
 &\quad \times u_0(t, t') \mathcal{H}_1(t') u_0(t', t'') \mathcal{H}_1(t'') u_0(t'', t_0) .
 \end{aligned} \tag{10.14}$$

The expansion can be expressed as

$$u(t, t_0) = u_0(t, t_0) O(t) + O(\lambda^3) , \tag{10.15}$$

where the operator $O(t)$ is given by

$$O(t) = 1 - \frac{i\lambda}{\hbar} \int_{t_0}^t dt' \mathcal{H}_{\text{II}}(t') - \frac{\lambda^2}{\hbar^2} \int_{t_0}^t dt' \int_{t_0}^{t'} dt'' \mathcal{H}_{\text{II}}(t') \mathcal{H}_{\text{II}}(t'') , \tag{10.16}$$

and where $\mathcal{H}_{\text{II}}(t)$, which is defined by

$$\mathcal{H}_{\text{II}}(t) \equiv u_0^\dagger(t, t_0) \mathcal{H}_1(t) u_0(t, t_0) , \tag{10.17}$$

is the so called *interaction representation* of \mathcal{H}_1 with respect to u_0 .

Exercise 10.2.1. Calculate the expectation value squared $|\langle O(t) \rangle|^2$ to lowest nonvanishing order in λ .

Solution 10.2.1. Since $\mathcal{H}_1(t)$ is Hermitian one finds that

$$\begin{aligned}
 &|\langle O(t) \rangle|^2 \\
 &= \left(1 - \frac{i\lambda}{\hbar} \int_{t_0}^t dt' \langle \mathcal{H}_{\text{II}}(t') \rangle - \frac{\lambda^2}{\hbar^2} \int_{t_0}^t dt' \int_{t_0}^{t'} dt'' \langle \mathcal{H}_{\text{II}}(t') \mathcal{H}_{\text{II}}(t'') \rangle \right) \\
 &\quad \times \left(1 + \frac{i\lambda}{\hbar} \int_{t_0}^t dt' \langle \mathcal{H}_{\text{II}}(t') \rangle - \frac{\lambda^2}{\hbar^2} \int_{t_0}^t dt' \int_{t_0}^{t'} dt'' \langle \mathcal{H}_{\text{II}}(t'') \mathcal{H}_{\text{II}}(t') \rangle \right) \\
 &= 1 + \frac{\lambda^2}{\hbar^2} \left(\int_{t_0}^t dt' \langle \mathcal{H}_{\text{II}}(t') \rangle \right)^2 \\
 &\quad - \frac{\lambda^2}{\hbar^2} \int_{t_0}^t dt' \int_{t_0}^{t'} dt'' (\langle \mathcal{H}_{\text{II}}(t') \mathcal{H}_{\text{II}}(t'') \rangle + \langle \mathcal{H}_{\text{II}}(t'') \mathcal{H}_{\text{II}}(t') \rangle) \\
 &\quad + O(\lambda^3) ,
 \end{aligned} \tag{10.18}$$

or

$$\begin{aligned}
 |\langle O(t) \rangle|^2 &= 1 + \frac{\lambda^2}{\hbar^2} \left(\int_{t_0}^t dt' \langle \mathcal{H}_{\text{I}}(t') \rangle \right)^2 \\
 &\quad - \frac{\lambda^2}{\hbar^2} \int_{t_0}^t dt' \int_{t_0}^t dt'' \langle \mathcal{H}_{\text{I}}(t') \mathcal{H}_{\text{I}}(t'') \rangle ,
 \end{aligned} \tag{10.19}$$

thus

$$\begin{aligned}
 |\langle O(t) \rangle|^2 &= 1 - \frac{\lambda^2}{\hbar^2} \int_{t_0}^t dt' \int_{t_0}^t dt'' \\
 &\quad \times [\langle \mathcal{H}_{\text{I}}(t') \mathcal{H}_{\text{I}}(t'') \rangle - \langle \mathcal{H}_{\text{I}}(t') \rangle \langle \mathcal{H}_{\text{I}}(t'') \rangle] ,
 \end{aligned} \tag{10.20}$$

or

$$|\langle O(t) \rangle|^2 = 1 - \frac{\lambda^2}{\hbar^2} \int_{t_0}^t dt' \int_{t_0}^t dt'' \langle \Delta \mathcal{H}_{\text{I}}(t') \Delta \mathcal{H}_{\text{I}}(t'') \rangle , \tag{10.21}$$

where

$$\Delta \mathcal{H}_{\text{I}}(t) = \mathcal{H}_{\text{I}}(t) - \langle \mathcal{H}_{\text{I}}(t) \rangle . \tag{10.22}$$

10.3 Transition Probability

Consider the case where the unperturbed Hamiltonian \mathcal{H}_0 is time independent. The eigenvectors of \mathcal{H}_0 are denoted as $|a_n\rangle$, and the corresponding eigenenergies are denoted as E_n

$$\mathcal{H}_0 |a_n\rangle = E_n |a_n\rangle , \tag{10.23}$$

where

$$\langle a_{n'} | a_n \rangle = \delta_{nn'} . \tag{10.24}$$

In this basis $u_0(t, t_0)$ is given by

$$u_0(t, t_0) = \exp\left(-\frac{i(t-t_0)}{\hbar} \mathcal{H}_0\right) = \sum_n \exp\left(-\frac{iE_n(t-t_0)}{\hbar}\right) |a_n\rangle \langle a_n| . \tag{10.25}$$

Assuming that initially at time t_0 the system is in state $|a_n\rangle$, what is the probability to find it later at time $t > t_0$ in the state $|a_m\rangle$? The answer to this question is the transition probability p_{nm} , which is given by

$$p_{nm} = |\langle a_m | u(t, t_0) | a_n \rangle|^2 . \quad (10.26)$$

With the help of Eq. (10.16) one finds that

$$\begin{aligned} e^{-\frac{iE_m(t-t_0)}{\hbar}} \langle a_m | u(t, t_0) | a_n \rangle &= \langle a_m | O(t) | a_n \rangle \\ &= \delta_{nm} - \frac{i\lambda}{\hbar} \int_{t_0}^t dt' \langle a_m | \mathcal{H}_{\text{II}}(t') | a_n \rangle \\ &\quad - \frac{\lambda^2}{\hbar^2} \int_{t_0}^t dt' \int_{t_0}^{t'} dt'' \langle a_m | \mathcal{H}_{\text{II}}(t') \mathcal{H}_{\text{II}}(t'') | a_n \rangle \\ &\quad + O(\lambda^3) , \end{aligned} \quad (10.27)$$

thus

$$\begin{aligned} p_{nm} &= \left| \delta_{nm} - \frac{i\lambda}{\hbar} \int_{t_0}^t dt' \langle a_m | \mathcal{H}_{\text{II}}(t') | a_n \rangle \right. \\ &\quad \left. - \frac{\lambda^2}{\hbar^2} \int_{t_0}^t dt' \int_{t_0}^{t'} dt'' \langle a_m | \mathcal{H}_{\text{II}}(t') \mathcal{H}_{\text{II}}(t'') | a_n \rangle + O(\lambda^3) \right|^2 . \end{aligned} \quad (10.28)$$

Exercise 10.3.1. Show that to second order in λ

$$p_{nn} = 1 - \sum_{m \neq n} p_{nm} . \quad (10.29)$$

Solution 10.3.1. For the case $m = n$ [see Eqs. (2.23), (10.21) and (10.27)]

$$\begin{aligned}
 p_{nm} &= |\langle a_n | u(t, t_0) | a_n \rangle|^2 \\
 &= |\langle a_n | O(t) | a_n \rangle|^2 \\
 &= 1 - \frac{\lambda^2}{\hbar^2} \int_{t_0}^t dt' \int_{t_0}^t dt'' \langle a_n | \Delta \mathcal{H}_{\text{I}}(t') \Delta \mathcal{H}_{\text{I}}(t'') | a_n \rangle \\
 &= 1 - \sum_m \frac{\lambda^2}{\hbar^2} \int_{t_0}^t dt' \int_{t_0}^t dt'' \langle a_n | \Delta \mathcal{H}_{\text{I}}(t') | a_m \rangle \langle a_m | \Delta \mathcal{H}_{\text{I}}(t'') | a_n \rangle \\
 &= 1 - \sum_m \frac{\lambda^2}{\hbar^2} \left| \int_{t_0}^t dt' \langle a_n | \Delta \mathcal{H}_{\text{I}}(t') | a_m \rangle \right|^2 \\
 &= 1 - \sum_m \frac{\lambda^2}{\hbar^2} \left| \int_{t_0}^t dt' \langle a_n | (\mathcal{H}_{\text{I}}(t') - \langle \mathcal{H}_{\text{I}}(t') \rangle) | a_m \rangle \right|^2 \\
 &= 1 - \sum_m \frac{\lambda^2}{\hbar^2} \left| \int_{t_0}^t dt' \langle a_n | \mathcal{H}_{\text{I}}(t') | a_m \rangle (1 - \delta_{nm}) \right|^2 \\
 &= 1 - \sum_{m \neq n} \frac{\lambda^2}{\hbar^2} \left| \int_{t_0}^t dt' \langle a_n | \mathcal{H}_{\text{I}}(t') | a_m \rangle \right|^2,
 \end{aligned}$$

thus Eq. (10.29) holds [see Eq. (10.28)].

In what follows, we calculate the transition probability p_{nm} to lowest nonvanishing order in λ for the case where $n \neq m$, for which the dominant contribution comes from the term of order λ in Eq. (10.28). For simplicity the initial time t_0 , at which the perturbation is turned on, is taken to be zero, i.e. $t_0 = 0$. We consider below the following cases:

10.3.1 The Stationary Case

In this case \mathcal{H}_{I} is assumed to be time independent (after being turned on at $t_0 = 0$). To lowest nonvanishing order in λ Eq. (10.28) yields

$$p_{nm} = \frac{\lambda^2}{\hbar^2} \left| \int_0^t dt' e^{i\omega_{mn}t'} \right|^2 |\langle a_m | \mathcal{H}_{\text{I}} | a_n \rangle|^2, \quad (10.30)$$

where

$$\omega_{mn} = \frac{E_m - E_n}{\hbar}. \quad (10.31)$$

Using the identity

$$\int_0^t dt' e^{i\Omega t'} = 2e^{i\frac{\Omega t}{2}} \frac{\sin\left(\frac{\Omega t}{2}\right)}{\Omega}, \quad (10.32)$$

one finds that

$$p_{nm} = \frac{4}{\hbar^2} \frac{\sin^2 \frac{\omega_{mn} t}{2}}{\omega_{mn}^2} |\langle a_m | \lambda \mathcal{H}_1 | a_n \rangle|^2 . \quad (10.33)$$

Note that in the limit $t \rightarrow \infty$ one finds with the help of Eq. (10.32) that

$$\begin{aligned} \lim_{t \rightarrow \infty} \frac{4 \sin^2 \left(\frac{\Omega t}{2} \right)}{\Omega^2} &= \lim_{t \rightarrow \infty} \left| \int_0^t e^{i\Omega t'} dt' \right|^2 \\ &= \lim_{t \rightarrow \infty} \int_0^t dt' \int_0^t dt'' e^{i\Omega(t'-t'')} \\ &= 2\pi\delta(\Omega) \int_0^t dt' \\ &= 2\pi t \delta(\Omega) . \end{aligned} \quad (10.34)$$

In this limit p_{nm} is proportional to the time t , i.e. p_{nm} can be expressed as $p_{nm} = w_{nm}t$, where w_{nm} is the transition rate, which is given by

$$w_{nm} = \frac{2\pi}{\hbar^2} \delta(\omega_{mn}) |\langle a_m | \lambda \mathcal{H}_1 | a_n \rangle|^2 . \quad (10.35)$$

The delta function $\delta(\omega_{mn})$ ensures that energy is conserved in the limit of long time, and transitions between states having different energies are excluded. However, such transitions have finite probability to occur for any finite time interval Δt . On the other hand, as can be seen from Eq. (10.33) (see also the figure below, which plots the function $f(x) = \sin^2 x/x^2$), the probability is significant only when $\omega_{mn}\Delta t \lesssim 1$, or alternatively when

$$\Delta E \Delta t \lesssim \hbar , \quad (10.36)$$

where $\Delta E = \hbar\omega_{mn}$.

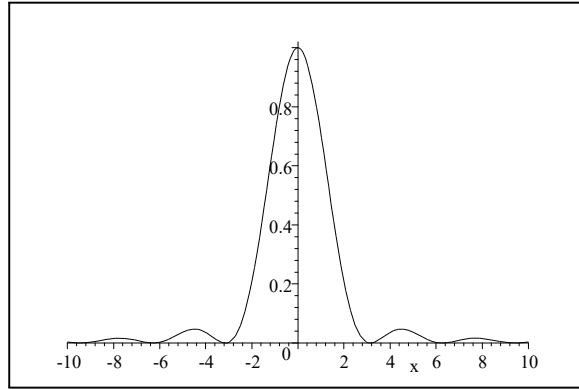

The function $f(x) = \sin^2 x/x^2$.

10.3.2 The Near-Resonance Case

In this case \mathcal{H}_1 is assumed to be given by

$$\mathcal{H}_1(t') = \mathcal{K}e^{-i\omega t'} + \mathcal{K}^\dagger e^{i\omega t'}, \quad (10.37)$$

where \mathcal{K} is an operator that is assumed to be time independent (after being turned on at $t_0 = 0$), and where the angular frequency ω is a positive constant. The transition probability is given by [see Eq. (10.28)]

$$p_{nm} = \frac{4}{\hbar^2} \left| \frac{e^{i\frac{(\omega_{mn}-\omega)t}}{2}} \sin\left(\frac{(\omega_{mn}-\omega)t}{2}\right) \langle a_m | \lambda \mathcal{K} | a_n \rangle}{\omega_{mn} - \omega} + \frac{e^{i\frac{(\omega_{mn}+\omega)t}}{2}} \sin\left(\frac{(\omega_{mn}+\omega)t}{2}\right) \langle a_m | \lambda \mathcal{K}^\dagger | a_n \rangle}{\omega_{mn} + \omega} \right|^2, \quad (10.38)$$

We refer to the case where $\omega = \omega_{mn}$ as absorption resonance, and to the case where $\omega = -\omega_{mn}$ as stimulated emission resonance. Near any of these resonances $\omega \simeq \pm\omega_{mn}$ the dominant contribution to p_{nm} comes from only one out of the two terms in Eq. (10.38), thus

$$p_{nm} \simeq \begin{cases} \frac{4}{\hbar^2} \frac{\sin^2\left(\frac{(\omega_{mn}-\omega)t}{2}\right)}{(\omega_{mn}-\omega)^2} |\langle a_m | \lambda \mathcal{K} | a_n \rangle|^2 & \omega_{mn} \simeq \omega \\ \frac{4}{\hbar^2} \frac{\sin^2\left(\frac{(\omega_{mn}+\omega)t}{2}\right)}{(\omega_{mn}+\omega)^2} |\langle a_m | \lambda \mathcal{K}^\dagger | a_n \rangle|^2 & \omega_{mn} \simeq -\omega \end{cases}. \quad (10.39)$$

In the *long time* limit, i.e. in the limit $t \rightarrow \infty$, the probability p_{nm} is found using Eq. (10.34) to be proportional to the time t , i.e. $p_{nm} = w_{nm}t$, where the transition rate w_{nm} is given by

$$w_{nm} \simeq \begin{cases} \frac{2\pi}{\hbar^2} \delta(\omega_{mn} - \omega) |\langle a_m | \lambda \mathcal{K} | a_n \rangle|^2 & \omega_{mn} \simeq \omega \\ \frac{2\pi}{\hbar^2} \delta(\omega_{mn} + \omega) |\langle a_m | \lambda \mathcal{K}^\dagger | a_n \rangle|^2 & \omega_{mn} \simeq -\omega \end{cases}. \quad (10.40)$$

In many cases of interest the final state $|a_m\rangle$ lie in a band of dense states. Let w_n be the total transition rate from the initial state $|a_n\rangle$. Assume that the matrix element $\langle a_m | \lambda \mathcal{K} | a_n \rangle$ does not vary significantly as a function of the energy E_m . For this case the total rate w_n can be expressed in terms of the density of states $g(E_m)$ (i.e. number of states per unit energy) in the vicinity of the final state $|a_m\rangle$ [see Eq. (10.40)] as

$$w_n = \frac{2\pi}{\hbar} g(E_m) |\langle a_m | \lambda \mathcal{K} | a_n \rangle|^2, \quad (10.41)$$

where $E_m = E_n + \hbar\omega$. This result is known as the Fermi's golden rule.

10.3.3 \mathcal{H}_1 is Separable

For this case it is assumed that \mathcal{H}_1 can be expressed as

$$\mathcal{H}_1(t') = f(t') \bar{\mathcal{H}}_1, \quad (10.42)$$

where $f(t')$ is a real function of time and where $\bar{\mathcal{H}}_1$ is time independent Hermitian operator. To lowest nonvanishing order in λ Eq. (10.28) yields

$$p_{nm} = \frac{1}{\hbar^2} \left| \int_0^t dt' e^{i\omega_{mn}t'} f(t') \right|^2 |\langle a_m | \lambda \bar{\mathcal{H}}_1 | a_n \rangle|^2. \quad (10.43)$$

10.4 Problems

1. Find the exact time evolution operator $u(t, 0)$ of the Hamiltonian \mathcal{H} , which is given by

$$\mathcal{H} = \mathcal{H}_0 + \mathcal{H}_p, \quad (10.44)$$

where

$$\mathcal{H}_0 = \hbar\omega a^\dagger a, \quad (10.45)$$

$$\mathcal{H}_p = i\hbar\omega\zeta(t) \left(e^{2i(\omega t - \phi)} a^2 - e^{-2i(\omega t - \phi)} a^{\dagger 2} \right), \quad (10.46)$$

a and a^\dagger are the annihilation and creation operators (as defined in chapter 5), ω is positive, ϕ is real and $\zeta(t)$ is an arbitrary real function of time t .

2. Consider a spin $S = 1$ particle, whose Hamiltonian is given by

$$\mathcal{H} = \mathcal{H}_0 + \mathcal{H}_p, \quad (10.47)$$

where \mathcal{H}_0 is given by $\mathcal{H}_0 = \omega_0 S_z$, \mathcal{H}_p is given by

$$\mathcal{H}_p = \frac{i\zeta(t)}{\hbar} \left(e^{2i(\omega_0 t - \phi)} S_-^2 - e^{-2i(\omega_0 t - \phi)} S_+^2 \right), \quad (10.48)$$

ω_0 and ϕ are real, $\zeta(t)$ is an arbitrary real function of time t , and S_\pm and S_z are angular momentum operators [see Eqs. (6.63), (6.64), (6.65) and (6.66) for the case $j = 1$]. Calculate the system's time evolution.

3. Consider a particle having mass m moving under the influence of a one-dimensional potential given by

$$V(x) = \frac{m\omega_0^2 x^2}{2}, \quad (10.49)$$

where the angular resonance frequency ω_0 is a constant. A perturbation given by

$$\mathcal{H}_1(t') = 2\alpha x \cos(\omega t') , \quad (10.50)$$

where the real constant α is assumed to be small, is turned on at time $t = 0$. Given that the system was initially at time $t = 0$ in the ground state $|0\rangle$ of the unperturbed Hamiltonian, calculate the transition probability $p_{n0}(t)$ to the number state $|n\rangle$ to lowest nonvanishing order in the perturbation expansion.

4. Repeat the previous exercise with the perturbation

$$\mathcal{H}_1(t') = x f(t') , \quad (10.51)$$

where the force $f(t')$ is given by

$$f(t') = \alpha \frac{\exp\left(-\frac{t'^2}{\tau^2}\right)}{\sqrt{\pi}\tau} , \quad (10.52)$$

and where both α and τ are real. Given that the system was initially at time $t \rightarrow -\infty$ in the ground state $|0\rangle$ of the unperturbed Hamiltonian, find the transition probability p_{n0} to the number state $|n\rangle$ in the limit $t \rightarrow \infty$. Compare your approximated result with the exact result given by Eq. (5.373).

5. Consider a harmonic oscillator of angular frequency ω and mass m . A time dependent force is applied $f(t)$. The function $f(t)$ is assumed to vanish $f(t) \rightarrow 0$ in the limit $t \rightarrow \pm\infty$. The oscillator is initially prepared in its ground state $|0\rangle$ at $t \rightarrow -\infty$. Let p_n be the probability to find the oscillator in the number state $|n\rangle$ in the limit $t \rightarrow \infty$. Calculate the ratio p_2/p_1^2 in the limit where $p_1 \ll 1$.
6. Consider a spin $1/2$ particle. The Hamiltonian is given by

$$\mathcal{H} = \omega S_x , \quad (10.53)$$

where ω is a Larmor frequency and where S_x is the x component of the angular momentum operator. Given that the spin is initially at time $t = 0$ in the eigenstate $|+\hat{\mathbf{z}}\rangle$ of the operator S_z (having eigenvalue $+\hbar/2$), what is the probability $p_{++}(t)$ to find the spin at the same state $|+\hat{\mathbf{z}}\rangle$ at a later time t . Compare the exact result with the approximated value that is obtained from Eq. (10.21).

7. Consider a particle having mass m confined in a potential well given by

$$V(x) = \begin{cases} 0 & \text{if } 0 \leq x \leq a \\ \infty & \text{if } x < 0 \text{ or } x > a \end{cases} . \quad (10.54)$$

The particle is initially at time $t \rightarrow -\infty$ in the ground state of the well. A small perturbation

$$\lambda \mathcal{H}_1(t) = \lambda \frac{\hbar}{\tau a} x e^{-\left(\frac{t}{\tau}\right)^2} , \quad (10.55)$$

where $\lambda \ll 1$ and where τ is a positive constant having the dimensions of time, is applied. Calculate the probability to find the particle in the first excited state in the limit $t \rightarrow \infty$.

8. Consider the transition between the energy eigenstates $|a_n\rangle$ and $|a_m\rangle$ of the unperturbed Hamiltonian \mathcal{H}_0 , which is assumed to be time independent, due to harmonic perturbation given by $\mathcal{H}_1(t') = \mathcal{K}e^{-i\omega t'} + \mathcal{K}^\dagger e^{i\omega t'}$ [see Eq. (10.37)], where \mathcal{K} is an operator that is assumed to be time independent (after being turned on at $t_0 = 0$). Calculate to second order in perturbation theory the transition rate w_{nm} in the long time limit for the case where the first order contribution vanishes, i.e. for the case where $\langle a_m | \mathcal{K} | a_n \rangle = 0$.
9. Consider a harmonic oscillator having angular frequency ω_0 and mass m . For time $t < 0$ the harmonic oscillator is in its ground state. At time $t = 0$ the time-periodic perturbation $\mathcal{H}_1(t)$ is turned on, where

$$\mathcal{H}_1(t) = -qE_0x \cos(\omega t) , \quad (10.56)$$

both q (the charge) and E_0 (the electric field) are assumed to be constants, and x is the position operator. Calculate to lowest nonvanishing order in E_0 the expectation value $\langle x \rangle(t)$ at time $t \geq 0$.

10. Consider a pair of spin 1/2 particles. Let $\mathbf{S}_n = (S_{nx}, S_{ny}, S_{nz})$ be the spin vector operator of the n 'th spin, where $n \in \{1, 2\}$. The Hamiltonian \mathcal{H} is given by $\mathcal{H} = \mathcal{H}_p + \mathcal{H}_d$. The term \mathcal{H}_p , which is given by

$$\begin{aligned} \mathcal{H}_p &= \omega_1 S_{1z} + \omega_2 S_{2z} \\ &+ \hbar^{-1} \kappa S_{1+} S_{2-} + \hbar^{-1} \kappa^* S_{1-} S_{2+} , \end{aligned} \quad (10.57)$$

is the Hamiltonian of the pair, where ω_1 and ω_2 are positive constants, κ is a complex constant and $S_{n\pm} = S_{nx} \pm iS_{ny}$, and the term \mathcal{H}_d , which is given by

$$\mathcal{H}_d = (\omega_{d1} S_{1+} + \omega_{d2} S_{2+}) e^{-i\omega t} + (\omega_{d1} S_{1-} + \omega_{d2} S_{2-}) e^{i\omega t} ,$$

is the Hamiltonian of the driving, where ω , ω_{d1} and ω_{d2} are positive constants. The notation $|\eta_1, \eta_2\rangle$ is used to label the common eigenvectors of the operators S_{1z} and S_{2z}

$$S_{1z} |\eta_1, \eta_2\rangle = \eta_1 \frac{\hbar}{2} |\eta_1, \eta_2\rangle , \quad (10.58)$$

$$S_{2z} |\eta_1, \eta_2\rangle = \eta_2 \frac{\hbar}{2} |\eta_1, \eta_2\rangle , \quad (10.59)$$

where $\eta_1 \in \{+, -\}$ and $\eta_2 \in \{+, -\}$. Calculate the transition rate $w_{|-, -\rangle \rightarrow |+, +\rangle}$ from the state $|-, -\rangle$ to the state $|+, +\rangle$ to lowest nonvanishing order in the perturbation \mathcal{H}_d .

11. A time dependent electric field E given by

$$E(t') = E_0 \exp\left(-\frac{t'^2}{\tau^2}\right), \quad (10.60)$$

where both E_0 and τ are real constants, is applied to a hydrogen atom. Given that the atom was initially at time $t \rightarrow -\infty$ in its ground state $n = 1$, find in the limit $t \rightarrow \infty$ the transition probabilities $p_{2,l,m}$ to the first excited states having shell index number $n = 2$.

12. Consider a particle having mass m in a one-dimensional potential given by

$$V(x) = -\alpha\delta(x), \quad (10.61)$$

where $\delta(x)$ is the delta function, and where $\alpha > 0$. The particle initially occupies the ground state. A perturbation given by $U = f_0 x \cos(\omega t)$ is turned on at time $t = 0$, where both f_0 and ω are real constants. Calculate to lowest nonvanishing order in f_0 the transition rate w from the ground state in the long time limit.

13. **Floquet theorem** - The time-dependent Hamiltonian $\mathcal{H}(t)$ of a given physical system is periodic

$$\mathcal{H}(t) = \mathcal{H}(t + T), \quad (10.62)$$

where T is the period time. The time evolution operator from time t_0 to time t_1 is denoted by $u(t_1, t_0)$ [see Eq. (4.4)].

- a) Show that

$$u(t + T, t_0) = u(t, t_0) u(t_0 + T, t_0). \quad (10.63)$$

- b) Let \mathcal{H}_F be an Hermitian and time-independent operator satisfying the relation

$$u(t_0 + T, t_0) = e^{-i\hbar^{-1}T\mathcal{H}_F}. \quad (10.64)$$

Note that \mathcal{H}_F , which is called the Floquet Hamiltonian, generally depends on the chosen initial time t_0 . The Floquet time evolution operator is defined by

$$u_F(t) = u(t, t_0) e^{i\hbar^{-1}(t-t_0)\mathcal{H}_F}. \quad (10.65)$$

Note that [see Eq. (10.65)]

$$u(t, t_0) = u_F(t) e^{-i\hbar^{-1}(t-t_0)\mathcal{H}_F}. \quad (10.66)$$

Show that

$$u_F(t) = u_F(t + T). \quad (10.67)$$

c) Show that [compare with Eq. (6.375)]

$$\hbar^{-1}\mathcal{H}_F = -iu_F^\dagger \frac{du_F}{dt} + \hbar^{-1}u_F^\dagger \mathcal{H}u_F, \quad (10.68)$$

and

$$\hbar^{-1}\mathcal{H} = i\frac{du_F}{dt}u_F^\dagger + \hbar^{-1}u_F\mathcal{H}_F u_F^\dagger, \quad (10.69)$$

d) Let \mathcal{H}_F be the Floquet Hamiltonian (10.64) for a given initial time t_0 , and let \mathcal{H}'_F be the Floquet Hamiltonian corresponding to another initial time t'_0 . Show that

$$\mathcal{H}'_F = u(t'_0, t_0) \mathcal{H}_F u^\dagger(t'_0, t_0). \quad (10.70)$$

e) Let $\{|\phi_n\rangle\}$ be an orthonormal set of eigenvectors of \mathcal{H}_F satisfying the closure relation $1 = \sum_n |\phi_n\rangle \langle \phi_n|$ [see Eq. (2.23)] and

$$\mathcal{H}_F |\phi_n\rangle = \epsilon_n |\phi_n\rangle, \quad (10.71)$$

where ϵ_n is the eigenvalue of the eigenvector $|\phi_n\rangle$. Show that the time evolution of a general state $|\psi(t)\rangle$ is given by

$$|\psi(t)\rangle = \sum_n \langle \phi_n | \psi(0) \rangle e^{-i\hbar^{-1}(t-t_0)\epsilon_n} |m_n(t)\rangle, \quad (10.72)$$

where the Floquet mode $|m_n(t)\rangle$ is given by

$$|m_n(t)\rangle = u_F(t) |\phi_n\rangle. \quad (10.73)$$

Note that $|m_n(t)\rangle = |m_n(t+T)\rangle$ [see Eq. (10.67)].

f) Consider a spin 1/2 time periodic Hamiltonian $\mathcal{H}(t) = \mathcal{H}(t + 2\pi/\omega)$ given by $\mathcal{H} = \omega_0 S_z + \omega_1 (\cos(\omega t) S_x + \sin(\omega t) S_y)$, where ω_0, ω_1 and ω are real constants [see Eq. (6.173)]. Find \mathcal{H}_F and u_F for the initial time $t_0 = 0$.

14. **Magnus expansion** - For a given operator L , \mathcal{C}_L maps a given operator A to $[L, A]$, i.e.

$$\mathcal{C}_L A = [L, A]. \quad (10.74)$$

a) Show that

$$\frac{de^L}{dt} e^{-L} = \sum_{n=0}^{\infty} \frac{\mathcal{C}_L^n}{(n+1)!} \frac{dL}{dt}. \quad (10.75)$$

b) Show that

$$\frac{dL}{dt} = \sum_{n=0}^{\infty} \frac{B_n \mathcal{C}_L^n}{n!} \left(\frac{de^L}{dt} e^{-L} \right), \quad (10.76)$$

where B_n is the n 'th Bernoulli number.

c) Consider the differential equation for the operator U

$$\frac{dU}{dt} = -i\Omega(t)U, \quad (10.77)$$

with initial condition $U(0) = U_0$, where $\Omega(t)$ is a given time dependent operator. Show that the solution can be expressed as

$$U(t) = e^{L(t)}U_0, \quad (10.78)$$

where the operator $L(t)$ satisfy $L(0) = 0$ and

$$\frac{dL}{dt} = -i \sum_{n=0}^{\infty} \frac{B_n \mathcal{C}_L^n}{n!} \Omega. \quad (10.79)$$

d) For the case where the operator Ω can be considered as small, Eq. (10.77) is written as

$$\frac{dU}{dt} = -i\epsilon\Omega(t)U, \quad (10.80)$$

where $|\epsilon|$ is considered as a small parameter. Evaluate L , which is given by Eq. (10.79), to second order in ϵ .

e) Calculate L to second order in ϵ for the case where Ω can be expanded as (for simplicity, the small parameter ϵ is omitted)

$$\Omega(t') = \sum_{m=-\infty}^{\infty} \Omega_m e^{im\frac{2\pi}{T}t'}. \quad (10.81)$$

f) Calculate L to second order in ϵ for the case where

$$\Omega(t') = \sum_{m=-\infty}^{\infty} \begin{pmatrix} 0 & \omega_m e^{im\frac{2\pi}{T}t'} \\ \omega_m^* e^{-im\frac{2\pi}{T}t'} & 0 \end{pmatrix}. \quad (10.82)$$

10.5 Solutions

1. Expressing the ket vector state as

$$|\psi\rangle = e^{-i\mathcal{H}_0 t/\hbar} |\psi_I\rangle, \quad (10.83)$$

and substituting into the Schrödinger equation, which is given by

$$i\hbar \frac{d|\psi\rangle}{dt} = (\mathcal{H}_0 + \mathcal{H}_p) |\psi\rangle, \quad (10.84)$$

yield

$$i\hbar \frac{d|\psi_I\rangle}{dt} = \mathcal{H}_I |\psi_I\rangle . \quad (10.85)$$

where \mathcal{H}_I , which is given by

$$\mathcal{H}_I = e^{i\mathcal{H}_0 t/\hbar} \mathcal{H}_p e^{-i\mathcal{H}_0 t/\hbar} , \quad (10.86)$$

is the interaction picture representation of \mathcal{H}_p . With the help of the vector identity (2.182), which is given by

$$e^L A e^{-L} = A + [L, A] + \frac{1}{2!} [L, [L, A]] + \frac{1}{3!} [L, [L, [L, A]]] + \dots , \quad (10.87)$$

and the relations

$$\frac{it}{\hbar} [\mathcal{H}_0, a^2] = -2i\omega t a^2 , \quad (10.88)$$

and

$$\frac{it}{\hbar} [\mathcal{H}_0, a^{\dagger 2}] = 2i\omega t a^{\dagger 2} , \quad (10.89)$$

one finds that

$$e^{i\mathcal{H}_0 t/\hbar} a^2 e^{-i\mathcal{H}_0 t/\hbar} = a^2 e^{-2i\omega t} , \quad (10.90)$$

$$e^{i\mathcal{H}_0 t/\hbar} a^{\dagger 2} e^{-i\mathcal{H}_0 t/\hbar} = a^{\dagger 2} e^{2i\omega t} , \quad (10.91)$$

thus

$$\mathcal{H}_I = i\hbar \zeta(t) (e^{-2i\phi} a^2 - e^{2i\phi} a^{\dagger 2}) . \quad (10.92)$$

Since $[\mathcal{H}_I(t), \mathcal{H}_I(t')] = 0$ the solution of Eq. (10.85) is given by

$$\begin{aligned} |\psi_I(t)\rangle &= \exp\left(-\frac{i}{\hbar} \int_0^t dt' \mathcal{H}_I(t')\right) |\psi_I(0)\rangle \\ &= S(\xi, \phi) |\psi_I(0)\rangle , \end{aligned} \quad (10.93)$$

where

$$S(\xi, \phi) = \exp[\xi (e^{-2i\phi} a^2 - e^{2i\phi} a^{\dagger 2})] , \quad (10.94)$$

and where

$$\xi = \int_0^t dt' \zeta(t') , \quad (10.95)$$

and thus the time evolution operator is thus given by

$$u(t, 0) = e^{-i\mathcal{H}_0 t/\hbar} S(\xi, \phi) . \quad (10.96)$$

2. Expressing the ket vector state as

$$|\psi\rangle = e^{-i\mathcal{H}_0 t/\hbar} |\psi_I\rangle, \quad (10.97)$$

and substituting into the Schrödinger equation, which is given by

$$i\hbar \frac{d|\psi\rangle}{dt} = (\mathcal{H}_0 + \mathcal{H}_p) |\psi\rangle, \quad (10.98)$$

yield

$$i\hbar \frac{d|\psi_I\rangle}{dt} = \mathcal{H}_I |\psi_I\rangle. \quad (10.99)$$

where \mathcal{H}_I , which is given by

$$\mathcal{H}_I = e^{i\mathcal{H}_0 t/\hbar} \mathcal{H}_p e^{-i\mathcal{H}_0 t/\hbar}, \quad (10.100)$$

is the interaction picture representation of \mathcal{H}_p . For the case of spin $S = 1$ the matrix representations of \mathcal{H}_0 and \mathcal{H}_p are give by

$$\hbar^{-1} \mathcal{H}_0 \doteq \omega_0 A_z, \quad (10.101)$$

and

$$\hbar^{-1} \mathcal{H}_p \doteq i\zeta(t) \left(e^{2i(\omega_0 t - \phi)} A_-^2 - e^{-2i(\omega_0 t - \phi)} A_+^2 \right), \quad (10.102)$$

where the matrices A_x , A_y and A_z are given by Eqs. (9.265), (9.266) and (9.267), respectively, and $A_{\pm} = A_x \pm iA_y$. With the help of the relations

$$A_+^2 = \begin{pmatrix} 0 & 0 & 2 \\ 0 & 0 & 0 \\ 0 & 0 & 0 \end{pmatrix}, \quad A_-^2 = \begin{pmatrix} 0 & 0 & 0 \\ 0 & 0 & 0 \\ 2 & 0 & 0 \end{pmatrix}, \quad (10.103)$$

one finds that

$$[A_z, A_+^2] = 2A_+^2, \quad (10.104)$$

$$[A_z, A_-^2] = -2A_-^2. \quad (10.105)$$

Using the vector identity (2.182) one finds that

$$e^{iA_z \omega_0 t} A_-^2 e^{-iA_z \omega_0 t} = e^{-2i\omega_0 t} A_-^2, \quad (10.106)$$

$$e^{iA_z \omega_0 t} A_+^2 e^{-iA_z \omega_0 t} = e^{2i\omega_0 t} A_+^2, \quad (10.107)$$

hence

$$\frac{\mathcal{H}_I}{\hbar} \doteq i\zeta(t) \left(e^{-2i\phi} A_-^2 - e^{2i\phi} A_+^2 \right). \quad (10.108)$$

Since $[\mathcal{H}_I(t), \mathcal{H}_I(t')] = 0$ for this case the solution of Eq. (10.99) is given by

$$|\psi_I(t)\rangle = \exp\left(-\frac{i}{\hbar} \int_0^t dt' \mathcal{H}_I(t')\right) |\psi_I(0)\rangle \quad (10.109)$$

$$= S(\xi, \phi) |\psi_I(0)\rangle, \quad (10.110)$$

where

$$S(\xi, \phi) = \exp\left(\xi \frac{e^{-2i\phi} S_-^2 - e^{2i\phi} S_+^2}{\hbar^2}\right), \quad (10.111)$$

and where

$$\xi = \int_0^t dt' \zeta(t'), \quad (10.112)$$

and thus the time evolution operator $u(t, 0)$ is given by

$$u(t, 0) = e^{-i\mathcal{H}_0 t/\hbar} S(\xi, \phi). \quad (10.113)$$

The following holds

$$\xi (e^{-2i\phi} A_-^2 - e^{2i\phi} A_+^2) = -2i\xi \begin{pmatrix} 0 & 0 & -ie^{2i\phi} \\ 0 & 0 & 0 \\ ie^{-2i\phi} & 0 & 0 \end{pmatrix}. \quad (10.114)$$

Using the identity [see Eq. (6.139)]

$$e^{-2i\xi \boldsymbol{\sigma} \cdot \hat{\mathbf{n}}} = \mathbf{1} \cos(2\xi) - i\boldsymbol{\sigma} \cdot \hat{\mathbf{n}} \sin(2\xi), \quad (10.115)$$

where $\boldsymbol{\sigma}$ is the Pauli matrix vector [see Eq. (6.137)], and the relation

$$\boldsymbol{\sigma} \cdot \hat{\mathbf{n}} = \begin{pmatrix} 0 & -ie^{2i\phi} \\ ie^{-2i\phi} & 0 \end{pmatrix}, \quad (10.116)$$

where

$$\hat{\mathbf{n}} = (\sin(2\phi), \cos(2\phi), 0), \quad (10.117)$$

one finds that the matrix representation of $S(\xi, \phi)$ is given by

$$S(\xi, \phi) \doteq \begin{pmatrix} \cos(2\xi) & 0 & -\sin(2\xi) e^{2i\phi} \\ 0 & 1 & 0 \\ \sin(2\xi) e^{-2i\phi} & 0 & \cos(2\xi) \end{pmatrix}. \quad (10.118)$$

Note that the eigenvalues of $S(\xi, \phi)$ are 1, $e^{2i\xi}$ and $e^{-2i\xi}$.

3. To lowest nonvanishing order in the perturbation expansion one finds using Eq. (10.39) together with Eqs. (5.11), (5.28) and (5.29) that

$$p_{n0}(t) = \frac{2\alpha^2}{m\hbar\omega} \frac{\sin^2 \frac{(\omega_0 - \omega)t}{2}}{(\omega_0 - \omega)^2} \delta_{n,1} . \quad (10.119)$$

4. To lowest nonvanishing order in perturbation expansion Eq. (10.43) yields

$$p_{n0} = \mu \delta_{n,1} , \quad (10.120)$$

where

$$\begin{aligned} \mu &= \frac{1}{2m\hbar\omega_0} \left| \int_{-\infty}^{\infty} dt' e^{i\omega_0 t'} f(t') \right|^2 \\ &= \frac{\alpha^2}{2m\hbar\omega_0} e^{-\frac{1}{2}\omega_0^2 \tau^2} . \end{aligned} \quad (10.121)$$

The exact result is found from Eq. (5.373)

$$p_n = \frac{e^{-\mu} \mu^n}{n!} . \quad (10.122)$$

To first order in μ both results agree.

5. With the help of Eqs. (5.11) and (10.28) one finds that to lowest nonvanishing order

$$p_1 = \frac{1}{2m\hbar\omega} \left| \int_{-\infty}^{\infty} dt' e^{i\omega t'} f(t') \right|^2 , \quad (10.123)$$

and [see Eqs. (5.28) and (5.29)]

$$\begin{aligned} p_2 &= 2 \left(\frac{1}{2m\hbar\omega} \right)^2 \left| \int_{-\infty}^{\infty} dt' f(t') e^{i\omega t'} \int_{-\infty}^{t'} dt'' f(t'') e^{i\omega t''} \right|^2 \\ &= \frac{1}{2} \left(\frac{1}{2m\hbar\omega} \right)^2 \left| \int_{-\infty}^{\infty} dt' f(t') e^{i\omega t'} \int_{-\infty}^{\infty} dt'' f(t'') e^{i\omega t''} \right|^2 , \end{aligned} \quad (10.124)$$

hence $p_2/p_1^2 \simeq 1/2$. Note that the same conclusion can be drawn from the exact solution given by Eq. (5.373) [recall that it is assumed that $p_1 \ll 1$, hence in Eq. (5.373) $\mu \ll 1$].

6. While the exact result is [see Eq. (6.509)]

$$p_{++}(t) = \cos^2 \frac{\omega t}{2} , \quad (10.125)$$

Eq. (10.21) yields

$$\begin{aligned}
 p_{++}(t) &= 1 - \frac{1}{\hbar^2} \int_0^t dt' \int_0^{t'} dt'' \langle +; \hat{\mathbf{z}} | (\omega S_x - \langle +; \hat{\mathbf{z}} | \omega S_x | +; \hat{\mathbf{z}} \rangle)^2 | +; \hat{\mathbf{z}} \rangle \\
 &= 1 - \frac{\omega^2 \langle +; \hat{\mathbf{z}} | S_x^2 | +; \hat{\mathbf{z}} \rangle}{\hbar^2} \int_0^t dt' \int_0^{t'} dt'' \\
 &= 1 - \left(\frac{\omega t}{2} \right)^2 .
 \end{aligned} \tag{10.126}$$

7. The normalized wavefunctions $\psi_n(x')$ of the well's energy eigenstates are given by

$$\psi_n(x') = \sqrt{\frac{2}{a}} \sin \frac{n\pi x'}{a} , \tag{10.127}$$

and the corresponding eigenenergies are

$$E_n = \frac{\hbar^2 \pi^2 n^2}{2ma^2} , \tag{10.128}$$

where $n = 1, 2, \dots$. The transition probability is calculated to lowest nonvanishing order in λ with the help of Eq. (10.43)

$$\begin{aligned}
 p_{2,1} &= \left(\frac{\lambda}{\tau a} \right)^2 \left| \int_0^t dt' e^{i(E_2 - E_1)t'/\hbar} e^{-\left(\frac{t'}{\tau}\right)^2} \right|^2 \\
 &\quad \times \left| \int_0^a dx' x' \sin \frac{2\pi x'}{a} \sin \frac{\pi x'}{a} \right|^2 ,
 \end{aligned} \tag{10.129}$$

thus [see Eq. (5.149)]

$$p_{2,1} = \frac{256\lambda^2}{81\pi^3} \exp\left(-\frac{9\pi^4 \hbar^2 \tau^2}{8m^2 a^4}\right) . \tag{10.130}$$

8. For the present case to second order in λ Eq. (10.27) becomes [see Eq. (10.25)]

$$\begin{aligned}
 &e^{-\frac{iE_m(t-t_0)}{\hbar}} \langle a_m | u(t, t_0) | a_n \rangle \\
 &= -\frac{\lambda^2}{\hbar^2} \sum_l \int_0^t dt' \int_0^{t'} dt'' e^{i\omega_{ml}t' + i\omega_{ln}t''} \langle a_m | \mathcal{H}_1(t) | a_l \rangle \langle a_l | \mathcal{H}_1(t) | a_n \rangle ,
 \end{aligned} \tag{10.131}$$

where

$$\omega_{mn} = \frac{E_m - E_n}{\hbar} , \tag{10.132}$$

or

$$\begin{aligned}
 & e^{-\frac{iE_m(t-t_0)}{\hbar}} \langle a_m | u(t, t_0) | a_n \rangle \\
 &= - \sum_l \frac{\lambda^2 \mathcal{K}_{ml} \mathcal{K}_{ln}}{\hbar^2} \int_0^t dt' \int_0^{t'} dt'' e^{i(\omega_{ml}-\omega)t' + i(\omega_{ln}-\omega)t''} \\
 &\quad - \sum_l \frac{\lambda^2 \mathcal{K}_{lm}^* \mathcal{K}_{ln}}{\hbar^2} \int_0^t dt' \int_0^{t'} dt'' e^{i(\omega_{ml}+\omega)t' + i(\omega_{ln}-\omega)t''} \\
 &\quad - \sum_l \frac{\lambda^2 \mathcal{K}_{ml} \mathcal{K}_{nl}^*}{\hbar^2} \int_0^t dt' \int_0^{t'} dt'' e^{i(\omega_{ml}-\omega)t' + i(\omega_{ln}+\omega)t''} \\
 &\quad - \sum_l \frac{\lambda^2 \mathcal{K}_{lm}^* \mathcal{K}_{nl}^*}{\hbar^2} \int_0^t dt' \int_0^{t'} dt'' e^{i(\omega_{ml}+\omega)t' + i(\omega_{ln}+\omega)t''} ,
 \end{aligned} \tag{10.133}$$

where

$$\mathcal{K}_{ln} = \langle a_l | \mathcal{K} | a_n \rangle . \tag{10.134}$$

With the help of the identity

$$\int_0^t dt' \int_0^{t'} dt'' e^{i\Omega_1 t' + i\Omega_2 t''} = \int_0^t dt' \frac{e^{i(\Omega_1 + \Omega_2)t'} - e^{i\Omega_1 t'}}{i\Omega_2} , \tag{10.135}$$

one finds that

$$\begin{aligned}
 & e^{-\frac{iE_m(t-t_0)}{\hbar}} \langle a_m | u(t, t_0) | a_n \rangle \\
 &= - \sum_l \frac{\lambda^2 \mathcal{K}_{ml} \mathcal{K}_{ln}}{i\hbar^2 (\omega_{ln} - \omega)} \int_0^t dt' \left(e^{i(\omega_{mn}-2\omega)t'} - e^{i(\omega_{ml}-\omega)t'} \right) \\
 &\quad - \sum_l \frac{\lambda^2 \mathcal{K}_{lm}^* \mathcal{K}_{ln}}{i\hbar^2 (\omega_{ln} - \omega)} \int_0^t dt' \left(e^{i\omega_{mn}t'} - e^{i(\omega_{ml}+\omega)t'} \right) \\
 &\quad - \sum_l \frac{\lambda^2 \mathcal{K}_{ml} \mathcal{K}_{nl}^*}{i\hbar^2 (\omega_{ln} + \omega)} \int_0^t dt' \left(e^{i\omega_{mn}t'} - e^{i(\omega_{ml}-\omega)t'} \right) \\
 &\quad - \sum_l \frac{\lambda^2 \mathcal{K}_{lm}^* \mathcal{K}_{nl}^*}{i\hbar^2 (\omega_{ln} + \omega)} \int_0^t dt' \left(e^{i(\omega_{mn}+2\omega)t'} - e^{i(\omega_{ln}+\omega)t'} \right) ,
 \end{aligned} \tag{10.136}$$

or

$$\begin{aligned}
 & e^{-\frac{iE_m(t-t_0)}{\hbar}} \langle a_m | u(t, t_0) | a_n \rangle \\
 = & - \sum_l \frac{\lambda^2 \mathcal{K}_{ml} \mathcal{K}_{ln}}{i\hbar^2 (\omega_{ln} - \omega)} \int_0^t dt' e^{i(\omega_{mn} - 2\omega)t'} \\
 & - \sum_l \frac{\lambda^2 \mathcal{K}_{lm}^* \mathcal{K}_{nl}^*}{i\hbar^2 (\omega_{ln} + \omega)} \int_0^t dt' e^{i(\omega_{mn} + 2\omega)t'} \\
 & + \sum_l \frac{\lambda^2 \left(\frac{\mathcal{K}_{ml} \mathcal{K}_{ln}}{\omega_{ln} - \omega} + \frac{\mathcal{K}_{ml} \mathcal{K}_{nl}^*}{\omega_{ln} + \omega} \right)}{i\hbar^2} \int_0^t dt' e^{i(\omega_{ml} - \omega)t'} \\
 & - \sum_l \frac{\lambda^2 \left(\frac{\mathcal{K}_{lm}^* \mathcal{K}_{ln}}{\omega_{ln} - \omega} + \frac{\mathcal{K}_{ml} \mathcal{K}_{nl}^*}{\omega_{ln} + \omega} \right)}{i\hbar^2} \int_0^t dt' e^{i\omega_{mn}t'} \\
 & + \sum_l \frac{\lambda^2 \mathcal{K}_{lm}^* \mathcal{K}_{ln}}{i\hbar^2 (\omega_{ln} - \omega)} \int_0^t dt' e^{i(\omega_{ml} + \omega)t'} \\
 & + \sum_l \frac{\lambda^2 \mathcal{K}_{lm}^* \mathcal{K}_{nl}^*}{i\hbar^2 (\omega_{ln} + \omega)} \int_0^t dt' e^{i(\omega_{ln} + \omega)t'} .
 \end{aligned} \tag{10.137}$$

By employing the identity [see Eq. (10.34)]

$$\lim_{t \rightarrow \infty} \left| \int_0^t e^{i\Omega t'} dt' \right|^2 = 2\pi t \delta(\Omega) , \tag{10.138}$$

the transition rate w_{nm} can be evaluated in the long time limit. To that end it is assumed that $\omega \neq \pm\omega_{ml}$ and $\omega \neq \pm\omega_{ln}$ (i.e. it is assumed that the harmonic perturbation is not at resonance with any first order transition between the initial $|a_n\rangle$ or final $|a_m\rangle$ states and an intermediate state $|a_l\rangle$), and it is further assumed that $\omega_{mn} > 0$ and that $\omega \geq 0$. Under these assumptions only the terms proportional to $\int_0^t dt' e^{i(\omega_{mn} - 2\omega)t'}$ in Eq. (10.137) are taken into account, and consequently the transition rate w_{nm} becomes

$$w_{nm} = \frac{2\pi}{\hbar^4} \left| \sum_l \frac{\lambda^2 \mathcal{K}_{ml} \mathcal{K}_{ln}}{\omega_{ln} - \omega} \right|^2 \delta(\omega_{mn} - 2\omega) . \tag{10.139}$$

9. For a general observable A and a general perturbation \mathcal{H}_1 the following holds to first order in perturbation theory [see Eq. (10.16)]

$$\langle A \rangle = \left\langle u_0^\dagger(t) A u_0(t) \right\rangle + \frac{i}{\hbar} \int_0^t dt' \langle [\mathcal{H}_{1\text{I}}(t'), A_{\text{I}}(t)] \rangle , \tag{10.140}$$

where $\mathcal{H}_{1\text{I}}$ and A_{I} are the interaction representations of \mathcal{H}_1 and A , respectively, i.e.

$$\mathcal{H}_{\text{I}}(t) = u_0^\dagger(t) \mathcal{H}_1(t) u_0(t) , \quad (10.141)$$

and

$$A_{\text{I}}(t) = u_0^\dagger(t) A u_0(t) , \quad (10.142)$$

where $u_0(t)$ is the time evolution operator corresponding to the unperturbed Hamiltonian. For the current case Eq. (10.140) yields [see Eq. (5.169)]

$$\begin{aligned} \langle x \rangle(t) &= \left\langle u_0^\dagger(t) x u_0(t) \right\rangle \\ &= -\frac{iqE_0}{\hbar m \omega_0} \int_0^t dt' \cos(\omega t') \left[\cos(\omega_0 t') \sin(\omega_0 t) \left\langle \left[x^{(\text{H})}(0), p^{(\text{H})}(0) \right] \right\rangle \right. \\ &\quad \left. + \sin(\omega_0 t') \cos(\omega_0 t) \left\langle \left[p^{(\text{H})}(0), x^{(\text{H})}(0) \right] \right\rangle \right] , \end{aligned} \quad (10.143)$$

thus [see Eq. (5.8)]

$$\begin{aligned} \langle x \rangle(t) &= \frac{qE_0}{m\omega_0} \int_0^t dt' \cos(\omega t') [\cos(\omega_0 t') \sin(\omega_0 t) - \sin(\omega_0 t') \cos(\omega_0 t)] \\ &= \frac{qE_0}{m} \frac{\cos(\omega t) - \cos(\omega_0 t)}{\omega_0^2 - \omega^2} . \end{aligned} \quad (10.144)$$

10. The matrix representation of $\hbar^{-1}\mathcal{H}_{\text{p}} \doteq M_{\text{p}}$ in the basis $\{|-, -\rangle, |+, -\rangle, |-, +\rangle, |+, +\rangle\}$ is given by

$$M_{\text{p}} = \begin{pmatrix} -\frac{\omega_1 + \omega_2}{2} & 0 & 0 & 0 \\ 0 & \delta & \kappa & 0 \\ 0 & \kappa^* & -\delta & 0 \\ 0 & 0 & 0 & \frac{\omega_1 + \omega_2}{2} \end{pmatrix} , \quad (10.145)$$

where

$$\delta = \frac{\omega_1 - \omega_2}{2} . \quad (10.146)$$

The eigenvectors of the matrix M_{p} are [see Eqs. (6.301) and (6.302)]

$$|g\rangle = [1 \ 0 \ 0 \ 0]^{\text{T}} , \quad (10.147)$$

$$|+\rangle = \left[0 \cos \frac{\theta}{2} e^{-\frac{i\varphi}{2}} \sin \frac{\theta}{2} e^{\frac{i\varphi}{2}} 0 \right]^{\text{T}} , \quad (10.148)$$

$$|-\rangle = \left[0 -\sin \frac{\theta}{2} e^{-\frac{i\varphi}{2}} \cos \frac{\theta}{2} e^{\frac{i\varphi}{2}} 0 \right]^{\text{T}} , \quad (10.149)$$

$$|e\rangle = [0 \ 0 \ 0 \ 1]^{\text{T}} , \quad (10.150)$$

where

$$\tan \theta = \frac{|\kappa|}{\delta}, \quad (10.151)$$

$$\kappa = |\kappa| e^{-i\varphi}, \quad (10.152)$$

and the following holds

$$M_p |g\rangle = -\frac{\omega_1 + \omega_2}{2} |g\rangle, \quad (10.153)$$

$$M_p |+\rangle = \omega_s |+\rangle, \quad (10.154)$$

$$M_p |-\rangle = -\omega_s |-\rangle, \quad (10.155)$$

$$M_p |e\rangle = \frac{\omega_1 + \omega_2}{2} |e\rangle, \quad (10.156)$$

where

$$\omega_s = \sqrt{\delta^2 + |\kappa|^2}. \quad (10.157)$$

The matrix representation of $\hbar^{-1}(\omega_{d1}S_{1+} + \omega_{d2}S_{2+}) \doteq K$ in the same basis $\{|-, -\rangle, |+, -\rangle, |-, +\rangle, |+, +\rangle\}$ is given by

$$K = \begin{pmatrix} 0 & 0 & 0 & 0 \\ \omega_{d1} & 0 & 0 & 0 \\ \omega_{d2} & 0 & 0 & 0 \\ 0 & \omega_{d2} & \omega_{d1} & 0 \end{pmatrix}. \quad (10.158)$$

To second order in perturbation theory the transition rate $w_{|-, -\rangle \rightarrow |+, +\rangle}$ is given by [see Eq. (10.139)]

$$w_{|-, -\rangle, |+, +\rangle} = 2\pi |\xi|^2 \delta(\omega_1 + \omega_2 - 2\omega), \quad (10.159)$$

where

$$\begin{aligned} \xi &= \frac{\langle e|K|+\rangle \langle +|K|g\rangle}{\frac{\omega_1 + \omega_2}{2} + \omega_s - \omega} + \frac{\langle e|K|-\rangle \langle -|K|g\rangle}{\frac{\omega_1 + \omega_2}{2} - \omega_s - \omega} \\ &= \left(\frac{\omega_1 + \omega_2}{2} - \omega \right) \frac{\langle e|K(|+\rangle \langle +| + |-\rangle \langle -|)K|g\rangle}{\left(\frac{\omega_1 + \omega_2}{2} - \omega \right)^2 - \omega_s^2} \\ &\quad - \omega_s \frac{\langle e|K(|+\rangle \langle +| - |-\rangle \langle -|)K|g\rangle}{\left(\frac{\omega_1 + \omega_2}{2} - \omega \right)^2 - \omega_s^2}. \end{aligned} \quad (10.160)$$

Using the relations

$$|+\rangle(+|+|-\rangle)(-|) = \begin{pmatrix} 0 & 0 & 0 & 0 \\ 0 & 1 & 0 & 0 \\ 0 & 0 & 1 & 0 \\ 0 & 0 & 0 & 0 \end{pmatrix}, \quad (10.161)$$

$$|+\rangle(+|+|-\rangle)(-|) = \begin{pmatrix} 0 & 0 & 0 & 0 \\ 0 & \cos \theta & \sin \theta e^{-i\varphi} & 0 \\ 0 & \sin \theta e^{i\varphi} & -\cos \theta & 0 \\ 0 & 0 & 0 & 0 \end{pmatrix}, \quad (10.162)$$

and [see Eqs. (10.151) and (10.157)]

$$\omega_s \sin \theta = |\kappa|, \quad (10.163)$$

one obtains

$$\xi = \frac{\omega_{d1}\omega_{d2}(\omega_1 + \omega_2 - 2\omega) - \omega_{d1}^2\kappa^* - \omega_{d2}^2\kappa}{\left(\frac{\omega_1 + \omega_2}{2} - \omega\right)^2 - \omega_s^2}. \quad (10.164)$$

When $\omega = (\omega_1 + \omega_2)/2$, i.e. when the argument of the delta function $\omega_1 + \omega_2 - 2\omega$ vanishes, this becomes

$$\xi = \frac{\omega_{d1}^2\kappa^* + \omega_{d2}^2\kappa}{\delta^2 + |\kappa|^2}, \quad (10.165)$$

and thus

$$w_{|-, -\rangle, |+ , +\rangle} = 2\pi \left| \frac{\omega_{d1}^2\kappa^* + \omega_{d2}^2\kappa}{\delta^2 + |\kappa|^2} \right|^2 \delta(\omega_1 + \omega_2 - 2\omega). \quad (10.166)$$

11. With the help of Eqs. (10.43), (9.152) and (9.153) one finds that

$$p_{2,l,m} = \frac{e^2 E_0^2}{\hbar^2} \left| \int_{-\infty}^{\infty} dt' e^{i\frac{3E_I}{4\hbar}t'} \frac{\exp\left(-\frac{t'^2}{\tau^2}\right)}{\sqrt{\pi}\tau} \right|^2 \times \left| \int_0^{\infty} dr r^3 R_{10} R_{2l} \int_{-1}^1 d(\cos \theta) \int_0^{2\pi} d\phi \cos \theta (Y_0^0)^* Y_l^m \right|^2, \quad (10.167)$$

where E_I is the ionization energy [see Eq. (7.66)]. The following holds [see Eq. (5.149)]

$$\int_{-\infty}^{\infty} dt' e^{i\frac{3E_I}{4\hbar}t'} \frac{\exp\left(-\frac{t'^2}{\tau^2}\right)}{\sqrt{\pi}\tau} = e^{-\frac{1}{4}\left(\frac{3E_I\tau}{4\hbar}\right)^2}, \quad (10.168)$$

and [see Eqs. (7.89), (7.90), (7.91) and (7.64)]

$$\int_0^{\infty} dr r^3 R_{10} R_{20} = -\frac{32\sqrt{2}a_0}{81}, \quad (10.169)$$

$$\int_0^{\infty} dr r^3 R_{10} R_{21} = \frac{128\sqrt{6}a_0}{243}, \quad (10.170)$$

thus [see Eqs. (6.130), (6.131) and (6.132)]

$$p_{2,1,0} = \frac{\pi 2^{15}}{3^{10}} \left(\frac{eE_0 a_0 \tau}{\hbar} \right)^2 e^{-\frac{1}{2} \left(\frac{3E_1 \tau}{4\hbar} \right)^2}, \quad (10.171)$$

and $p_{2,0,0} = p_{2,1,1} = p_{2,1,-1} = 0$.

12. The ground state has energy E_0 given by

$$E_0 = -\frac{m\alpha^2}{2\hbar^2},$$

and a wavefunction $\psi_{0,\alpha}(x')$ given by [see Eq. (4.202)]

$$\psi_{0,\alpha}(x') = \sqrt{\kappa} \exp(-\kappa|x'|), \quad (10.172)$$

where

$$\kappa = \frac{\sqrt{-2mE_0}}{\hbar} = \frac{m\alpha}{\hbar^2}. \quad (10.173)$$

The transition rate w can be calculated using Fermi's golden rule (10.41). To evaluate the energy density of states in Eq. (10.41), the confining potential is first assumed to be given by

$$V(x) = \begin{cases} -\alpha\delta(x) & |x| < \frac{L}{2} \\ \infty & |x| \geq \frac{L}{2} \end{cases}, \quad (10.174)$$

where L is the length of the region of confinement. The rate w is evaluated below in the limit of $L \rightarrow \infty$. Wavefunctions of energy eigenvectors have definite parity, since $V(x) = V(-x)$. However for the perturbation $U = f_0 x \cos(\omega t)$, matrix elements are nonzero only for final states having a wavefunction of odd parity [see Eq. (4.202)]. For such energy eigenvectors, the delta function well $-\alpha\delta(x)$ has no effect on the wavefunction, since odd parity wavefunctions vanish at $x = 0$. In the limit $L \rightarrow \infty$, the final states' wavefunctions can be taken to be given by

$$\psi_f(x') = \sqrt{\frac{2}{L}} \sin(kx'), \quad (10.175)$$

where k is positive, and the corresponding energy is

$$E_f = \frac{\hbar^2 k^2}{2m} . \quad (10.176)$$

The spacing between allowed values of k is $4\pi/L$ [compare with Eq. (16.77), and recall that only states having odd parity contribute to the rate w], and the corresponding energy E_f spacing is $2E_f (4\pi/(kL))$ [compare to Eq. (16.298)]. Thus, for $\hbar\omega \geq -E_0$, to first order in f_0 the rate w is given by [see Eqs. (10.40) and (10.41), and note that $E_f - E_0 = \hbar\omega$]

$$\begin{aligned} w &= \lim_{L \rightarrow \infty} \frac{2\pi}{\hbar} \frac{1}{2E_f (4\pi/(kL))} \left| \int_{-\frac{L}{2}}^{\frac{L}{2}} dx' \frac{f_0 x' \psi_{0,\alpha}(x') \psi_f(x')}{2} \right|^2 \\ &= \frac{f_0^2 \kappa k}{2\hbar E_f} \left| \int_0^\infty dx' x' \exp(-\kappa|x'|) \sin(kx') \right|^2 \\ &= \frac{f_0^2 \kappa k}{2\hbar E_f} \frac{4\kappa^2 k^2}{(\kappa^2 + k^2)^4} \\ &= \frac{f_0^2 (-E_0)^{3/2} (\hbar\omega + E_0)^{1/2}}{\hbar^3 m \omega^4} . \end{aligned} \quad (10.177)$$

13. For a general time evolution operator u the following holds [see Eq. (4.4)]

$$u(t_1 + t_2, t_0) = u(t_1 + t_2, t_1) u(t_1, t_0) . \quad (10.178)$$

a) The following holds [Eq. (10.178)]

$$u(t + T, t_0) = u(t + T, t_0 + T) u(t_0 + T, t_0) , \quad (10.179)$$

and [see Eqs. (10.8) and (10.62)]

$$u(t + T, t_0 + T) = u(t, t_0) , \quad (10.180)$$

thus Eq. (10.63) holds.

b) The following holds [see Eqs. (10.65), (10.63) and (10.64)]

$$\begin{aligned} u_F(t + T) &= u(t + T, t_0) e^{i\hbar^{-1}(t+T-t_0)\mathcal{H}_F} \\ &= u(t, t_0) u(t_0 + T, t_0) e^{i\hbar^{-1}(t+T-t_0)\mathcal{H}_F} \\ &= u(t, t_0) e^{-i\hbar^{-1}T\mathcal{H}_F} e^{i\hbar^{-1}(t+T-t_0)\mathcal{H}_F} \\ &= u(t, t_0) e^{i\hbar^{-1}(t-t_0)\mathcal{H}_F} , \end{aligned} \quad (10.181)$$

thus Eq. (10.67) holds.

c) By substituting Eq. (10.66) into the Schrödinger equation for u (4.7) one obtains

$$i\hbar \frac{d}{dt} \left(u_{\text{F}}(t) e^{-i\hbar^{-1}(t-t_0)\mathcal{H}_{\text{F}}} \right) = \mathcal{H}u_{\text{F}}(t) e^{-i\hbar^{-1}(t-t_0)\mathcal{H}_{\text{F}}} , \quad (10.182)$$

thus Eq. (10.68) holds. By multiplying Eq. (10.68) from the left by u_{F} , and from the right by u_{F}^\dagger , one obtains Eq. (10.69).

d) With the help of Eqs. (10.64), (10.178) and (10.180) one finds that

$$\begin{aligned} e^{-i\hbar^{-1}T\mathcal{H}'_{\text{F}}} &= u(t'_0 + T, t'_0) \\ &= u(t'_0 + T, t_0 + T) u(t_0 + T, t_0) u^\dagger(t'_0, t_0) \\ &= u(t'_0 + T, t_0 + T) e^{-i\hbar^{-1}T\mathcal{H}_{\text{F}}} u^\dagger(t'_0, t_0) \\ &= u(t'_0, t_0) e^{-i\hbar^{-1}T\mathcal{H}_{\text{F}}} u^\dagger(t'_0, t_0) , \end{aligned} \quad (10.183)$$

thus Eq. (10.70) holds.

e) With the help of Eqs. (10.66) and (10.71) one finds that

$$\begin{aligned} |\psi(t)\rangle &= u(t, t_0) |\psi(0)\rangle \\ &= \sum_n u_{\text{F}}(t) e^{-i\hbar^{-1}(t-t_0)\mathcal{H}_{\text{F}}} |\phi_n\rangle \langle \phi_n | \psi(0)\rangle \\ &= \sum_n \langle \phi_n | \psi(0)\rangle e^{-i\hbar^{-1}(t-t_0)\epsilon_n} u_{\text{F}}(t) |\phi_n\rangle , \end{aligned} \quad (10.184)$$

thus Eq. (10.72) holds.

f) For this case [see Eqs. (6.376), (6.381) and (10.66)]

$$u_{\text{F}}(t) \doteq \begin{pmatrix} e^{-\frac{i\omega t}{2}} & 0 \\ 0 & e^{\frac{i\omega t}{2}} \end{pmatrix} , \quad (10.185)$$

and

$$\hbar^{-1}\mathcal{H}_{\text{F}} = \frac{(\omega_0 - \omega)\sigma_z + \omega_1\sigma_x}{2} . \quad (10.186)$$

14. In terms of \mathcal{C}_L , the identity (2.182) can be rewritten as

$$e^L A e^{-L} = \exp(\mathcal{C}_L) A . \quad (10.187)$$

a) Using the mapping (10.74), Eq. (2.189) can be written as [see Eq. (10.187)]

$$\begin{aligned} \frac{d}{dt} e^{L(t)} &= \int_0^1 d\eta \left(e^{\eta L} \frac{dL}{dt} e^{-\eta L} \right) e^L \\ &= \int_0^1 d\eta \left(\exp(\mathcal{C}_{\eta L}) \frac{dL}{dt} \right) e^L , \end{aligned} \quad (10.188)$$

thus

$$\begin{aligned}
 \frac{de^{L(t)}}{dt} e^{-L} &= \int_0^1 d\eta \sum_{n=0}^{\infty} \frac{C_{\eta L}^n}{n!} \frac{dL}{dt} \\
 &= \int_0^1 d\eta \sum_{n=0}^{\infty} \frac{\eta^n C_L^n}{n!} \frac{dL}{dt} \\
 &= \sum_{n=0}^{\infty} \left(\int_0^1 d\eta \eta^n \right) \frac{C_L^n}{n!} \frac{dL}{dt} \\
 &= \sum_{n=0}^{\infty} \frac{C_L^n}{(n+1)!} \frac{dL}{dt} .
 \end{aligned} \tag{10.189}$$

b) The term $(de^L/dt) e^{-L}$ can be expressed as [see Eq. (10.75)]

$$\begin{aligned}
 \frac{de^L}{dt} e^{-L} &= \sum_{n=0}^{\infty} \frac{C_L^n}{(n+1)!} \frac{dL}{dt} \\
 &= g_B(C_L) \frac{dL}{dt} ,
 \end{aligned} \tag{10.190}$$

where the function $g_B(x)$ is given by

$$g_B(x) = \frac{e^x - 1}{x} = \sum_{n=0}^{\infty} \frac{x^n}{(n+1)!} . \tag{10.191}$$

The function $1/(g_B(x))$ is related to the Bernoulli numbers B_n by

$$\begin{aligned}
 \frac{1}{g_B(x)} &= \frac{x}{e^x - 1} \\
 &= \sum_{n=0}^{\infty} \frac{B_n x^n}{n!} \\
 &= 1 - \frac{x}{2} + \frac{x^2}{12} - \frac{x^4}{720} + \frac{x^6}{30240} + \dots .
 \end{aligned} \tag{10.192}$$

Multiplying by $1/(g_B(C_L))$ yields

$$\frac{dL}{dt} = \frac{1}{g_B(C_L)} \frac{de^L}{dt} e^{-L} = \sum_{n=0}^{\infty} \frac{B_n C_L^n}{n!} \left(\frac{de^L}{dt} e^{-L} \right) . \tag{10.193}$$

c) Substituting Eq. (10.78) into Eq. (10.77) yields

$$\frac{de^L}{dt} = -i\Omega e^L , \tag{10.194}$$

thus a solution of Eq. (10.77) must satisfy [see Eqs. (10.75) and (10.190)]

$$\frac{d e^L}{dt} e^{-L} = g_B(\mathcal{C}_L) \frac{dL}{dt} = -i\Omega. \quad (10.195)$$

Multiplying by $1/g_B(\mathcal{C}_L)$ leads to Eq. (10.79) [see Eq. (10.193)].

- d) By substituting the operator L , which is expanded as a power series in ϵ as

$$L = \sum_{n=1}^{\infty} \epsilon^n L_n, \quad (10.196)$$

into Eq. (10.79), which is written as [see Eqs. (10.74) and (10.192)]

$$\frac{dL}{dt} = -i\Omega + i \frac{[L, \Omega]}{2} - i \frac{[L, [L, \Omega]]}{12} + i \frac{[L, [L, [L, \Omega]]]}{720} + \dots, \quad (10.197)$$

one finds by collecting terms of first and second order in ϵ that

$$\frac{dL_1}{dt} = -i\Omega, \quad (10.198)$$

$$\frac{dL_2}{dt} = i \frac{[L_1, \Omega]}{2}. \quad (10.199)$$

Integration yields

$$L_1 = -i \int_0^t dt' \Omega(t'), \quad (10.200)$$

and

$$L_2 = -\frac{1}{2} \int_0^t dt' \int_0^{t'} dt'' [\Omega(t'), \Omega(t'')]. \quad (10.201)$$

- e) For this case [see Eqs. (10.81), (10.200) and (10.201)]

$$\begin{aligned} L &= L_1 + L_2 \\ &= -i \sum_{m=-\infty}^{\infty} \eta_m \Omega_m \\ &\quad - \frac{1}{2} \sum_{m'=-\infty}^{\infty} \sum_{m''=-\infty}^{\infty} \zeta_{m',m''} [\Omega_{m'}, \Omega_{m''}], \end{aligned} \quad (10.202)$$

where

$$\eta_m = \int_0^t dt' e^{im \frac{2\pi}{t} t'} = t \delta_{m,0}, \quad (10.203)$$

and

$$\begin{aligned} \zeta_{m',m''} &= \int_0^t dt' \int_0^{t'} dt'' e^{im' \frac{2\pi}{\hbar} t'} e^{im'' \frac{2\pi}{\hbar} t''} \\ &= \begin{cases} \frac{t^2}{2} & m' = m'' = 0 \\ \frac{it^2}{2\pi m''} & m' = 0 \text{ and } m'' \neq 0 \\ -\frac{it^2}{2\pi m'} & m' \neq 0 \text{ and } m'' = 0 \\ \frac{it^2}{2\pi m'} & m' = -m'' \neq 0 \\ 0 & \text{else} \end{cases}, \end{aligned} \quad (10.204)$$

thus

$$\begin{aligned} L &= L_1 + L_2 \\ &= -i\Omega_0 t - \sum_{m'=1}^{\infty} \frac{it^2}{2\pi m'} ([\Omega_0, \Omega_{m'} - \Omega_{-m'}] + [\Omega_{m'}, \Omega_{-m'}]) . \end{aligned} \quad (10.205)$$

f) For this case [see Eq. (10.82)]

$$\Omega_m = \begin{pmatrix} 0 & \omega_m \\ \omega_{-m}^* & 0 \end{pmatrix},$$

and thus with the help of the identities

$$\left[\begin{pmatrix} 0 & x \\ x^* & 0 \end{pmatrix}, \begin{pmatrix} 0 & y \\ -y^* & 0 \end{pmatrix} \right] = -2 \operatorname{Re}(x^* y) \sigma_z, \quad (10.206)$$

and

$$\left[\begin{pmatrix} 0 & x \\ y^* & 0 \end{pmatrix}, \begin{pmatrix} 0 & y \\ x^* & 0 \end{pmatrix} \right] = (|x|^2 - |y|^2) \sigma_z, \quad (10.207)$$

where [see Eq. (6.137)]

$$\sigma_z = \begin{pmatrix} 1 & 0 \\ 0 & -1 \end{pmatrix}, \quad (10.208)$$

one finds that [see Eq. (10.205)]

$$\begin{aligned} L &= -i\Omega_0 t \\ &\quad - \sum_{m'=1}^{\infty} \frac{it^2 \left(|\omega_{m'}|^2 - |\omega_{-m'}|^2 - 2 \operatorname{Re}(\omega_0^* (\omega_{m'} - \omega_{-m'})) \right)}{2\pi m'} \sigma_z . \end{aligned} \quad (10.209)$$

Note that for the case $\omega_m = \omega_{\text{pa}} \delta_{m,2}$, Eq. (10.209) yields $L = (-it^2/(4\pi)) |\omega_{\text{pa}}|^2 \sigma_z$ [compare with the Bloch-Siegert shift given by Eq. (6.411)].

11. WKB Approximation

The theory of geometrical optics provides an approximated solution to Maxwell's equation that is valid for systems whose typical size scales are much larger than the wavelength λ of electromagnetic waves. In 1926 using a similar approach the physicists Wentzel, Kramers and Brillouin (WKB) independently found an approximated solution to the Schrödinger equation in the coordinate representation for the case where the wavelength associated with the wavefunction (to be defined below) can be considered as short. Below the WKB approximation is discussed for the time independent and one-dimensional case. This chapter is mainly based on Ref. [3].

11.1 WKB Wavefunction

Consider a point particle having mass m moving under the influence of a one-dimensional potential $V(x)$. The time independent Schrödinger equation for the wavefunction $\psi(x)$ is given by [see Eq. (4.53)]

$$\frac{d^2\psi(x)}{dx^2} + \frac{2m}{\hbar^2} (E - V(x)) \psi(x) = 0, \quad (11.1)$$

where E is the energy. In terms of the local momentum $p(x)$, which is defined by

$$p(x) = \sqrt{2m(E - V(x))}, \quad (11.2)$$

the Schrödinger equation becomes

$$\frac{d^2\psi(x)}{dx^2} + \left(\frac{p}{\hbar}\right)^2 \psi(x) = 0. \quad (11.3)$$

Using the notations

$$\psi(x) = e^{iW(x)/\hbar}, \quad (11.4)$$

and the relation

$$\frac{d^2\psi(x)}{dx^2} = \left(\frac{i}{\hbar} \frac{d^2W}{dx^2} - \left(\frac{1}{\hbar} \frac{dW}{dx} \right)^2 \right) \psi(x), \quad (11.5)$$

one finds that the Schrödinger equation can be written as

$$i\hbar \frac{d^2 W}{dx^2} - \left(\frac{dW}{dx} \right)^2 + p^2 = 0. \quad (11.6)$$

In the WKB approach the Planck's constant \hbar is treated as a small parameter. Expanding W as a power series in \hbar

$$W = W_0 + \hbar W_1 + \hbar^2 W_2 + \dots \quad (11.7)$$

one finds that

$$- \left(\frac{dW_0}{dx} \right)^2 + i\hbar \frac{d^2 W_0}{dx^2} - 2\hbar \frac{dW_0}{dx} \frac{dW_1}{dx} + p^2 + O(\hbar^2) = 0. \quad (11.8)$$

The terms of order zero in \hbar yield

$$- \left(\frac{dW_0}{dx} \right)^2 + p^2 = 0. \quad (11.9)$$

thus

$$W_0(x) = \pm \int_{x_0}^x dx' p(x'), \quad (11.10)$$

where x_0 is a constant.

What is the range of validity of the zero order approximation? As can be seen by comparing Eq. (11.6) with Eq. (11.9), the approximation $W \simeq W_0$ is valid when the first term in Eq. (11.6) is negligibly small in absolute value in comparison with the second one, namely when

$$\hbar \left| \frac{d^2 W}{dx^2} \right| \ll \left| \frac{dW}{dx} \right|^2. \quad (11.11)$$

It is useful to express this condition in terms of the *local wavelength* $\lambda(x)$, which is given by

$$\lambda(x) = \frac{2\pi\hbar}{p(x)}. \quad (11.12)$$

By employing the lowest order approximation $dW/dx = \pm p$ the condition (11.11) becomes

$$\left| \frac{d\lambda}{dx} \right| \ll 2\pi. \quad (11.13)$$

This means that the approximation is valid provided that the change in wavelength over a distance of one wavelength is small.

The terms of 1st order in \hbar of Eq. (11.8) yield an equation for W_1

$$\frac{dW_1}{dx} = \frac{i}{2} \frac{\frac{d^2W_0}{dx^2}}{\frac{dW_0}{dx}} = \frac{i}{2} \frac{d}{dx} \log \left(\frac{dW_0}{dx} \right). \quad (11.14)$$

Using Eq. (11.9) one thus has

$$\frac{d}{dx} \left(iW_1 - \log \frac{1}{\sqrt{p}} \right) = 0. \quad (11.15)$$

Therefore, to 1st order in \hbar the wave function is given by

$$\psi(x) = C_+ \varphi_+(x) + C_- \varphi_-(x), \quad (11.16)$$

where

$$\varphi_{\pm}(x) = \frac{1}{\sqrt{p}} \exp \left(\pm \frac{i}{\hbar} \int_{x_0}^x dx' p(x') \right), \quad (11.17)$$

and where both C_+ and C_- are constants.

In general, the continuity equation (4.81), which is given by

$$\frac{d\rho}{dt} + \frac{dJ}{dx} = 0, \quad (11.18)$$

relates the probability distribution function $\rho = |\psi|^2$ and the current density $J = (\hbar/m) \text{Im}(\psi^* d\psi/dx)$ associated with a given one-dimensional wavefunction $\psi(x)$. For a stationary $\psi(x)$ the probability distribution function ρ is time independent, and thus J is a constant. Consider a region where $E > V(x)$. In such a region, which is classically accessible, the momentum $p(x)$ is real and positive, and thus the probability distribution function $\rho(x)$ of the WKB wavefunctions $\varphi_{\pm}(x)$ is proportional to $1/p$. This is exactly what is expected from a classical analysis of the dynamics, where the time spent near a point x is inversely proportional to the local classical velocity at that point $v(x) = p(x)/m$. With the help of Eq. (4.274) one finds that the current density J associated with the wavefunction (11.16) is given by

$$\begin{aligned} J &= \frac{\hbar}{m} \text{Im} \left((C_+^* \varphi_+^* + C_-^* \varphi_-^*) \left(C_+ \frac{d\varphi_+}{dx} + C_- \frac{d\varphi_-}{dx} \right) \right) \\ &= \frac{\hbar}{m} \left[|C_+|^2 \text{Im} \left(\varphi_+^* \frac{d\varphi_+}{dx} \right) + |C_-|^2 \text{Im} \left(\varphi_-^* \frac{d\varphi_-}{dx} \right) \right. \\ &\quad \left. + \text{Im} \left(C_+^* C_- \varphi_+^* \frac{d\varphi_-}{dx} + C_+ C_-^* \varphi_-^* \frac{d\varphi_+}{dx} \right) \right]. \end{aligned} \quad (11.19)$$

As can be seen from Eq. (11.17), the last term vanishes since $\varphi_-(x) = \varphi_+^*(x)$. Therefore, with the help of Eq. (6.608) one finds that

$$J = \frac{1}{m} \left(|C_+|^2 - |C_-|^2 \right). \quad (11.20)$$

Thus, the current density J associated with the state $\varphi_+(x)$ is positive, whereas $J < 0$ for $\varphi_-(x)$. Namely, $\varphi_+(x)$ describes a state propagating from left to right, whereas $\varphi_-(x)$ describes a state propagating in the opposite direction.

11.2 Turning Point

Consider a point $x = a$ for which $E = V(a)$, namely $p(a) = 0$ [see Fig. 11.1 (a)]. Such a point is called a *turning point* since a classical particle that reaches the point $x = a$ momentarily stops and changes its direction. Near a turning point the local wavelength λ diverges, and consequently, as can be seen from Eq. (11.13), the WKB approximation breaks down. Consider the case where $E > V(x)$ for $x > a$ and where $E < V(x)$ for $x < a$. In the region $x > a$ the WKB wave function is expressed using Eq. (11.16), where, for convenient, the constant x_0 is chosen to be a . However, on the other side of the turning point, namely for $x < a$, the momentum $p(x)$ becomes imaginary since $E < V(x)$. Thus, in this region, which is classically forbidden, the wave function given by Eq. (11.16) contains one exponentially decaying term in the limit $x \rightarrow -\infty$ and another exponentially diverging term in the same limit. To ensure that the wavefunction remains normalizable, the coefficient of the exponentially diverging term is required to vanish, and thus we seek a solution having the form

$$\psi(x) = \begin{cases} \frac{C}{\sqrt{|p|}} \exp\left(\frac{1}{\hbar} \int_a^x dx' |p|\right) & x < a \\ \frac{C_+}{\sqrt{p}} \exp\left(\frac{i}{\hbar} \int_a^x dx' p\right) + \frac{C_-}{\sqrt{p}} \exp\left(-\frac{i}{\hbar} \int_a^x dx' p\right) & x > a \end{cases}. \quad (11.21)$$

Note that the pre-factor $1/\sqrt{p}$ in the classically forbidden region $x < a$ is substituted in Eq. (11.21) by $1/\sqrt{|p|}$. The ratio between these two factors in the region $x < a$ is a constant, which is assumed to be absorbed by the constant C . For given value of C , what are the values of C_+ and C_- ? It should be kept in mind that Eq. (11.21) becomes invalid close to the turning point $x = a$ where the WKB approximation breaks down. Thus, this question cannot be simply answered by requiring that $\psi(x')$ and its first derivative are continuous at $x = a$ [e.g., see Eq. (4.173)].

As we have seen above, the WKB approximation breaks down near the turning point $x = a$. However the two regions $x < a$ and $x > a$ can be tailored together by the technique of analytical continuation. In the vicinity of the turning point, namely for $x \simeq a$, the potential $V(x)$ can be approximated by

$$V(x) \simeq V(a) - \alpha(x - a), \quad (11.22)$$

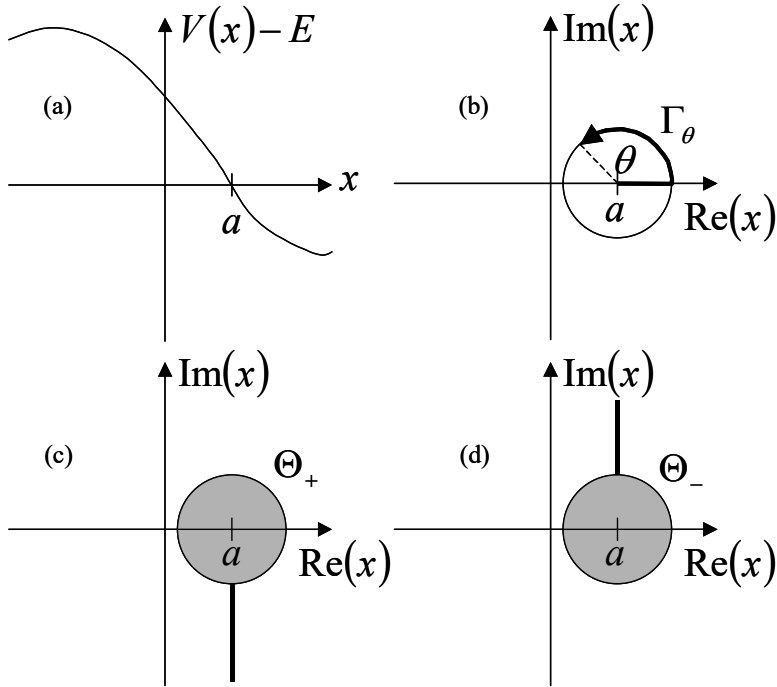

Fig. 11.1. (a) The turning point at $x = a$. (b) The integration trajectory Γ_θ . The singly connected region Θ_+ (c) and Θ_- (d).

where

$$\alpha = - \left. \frac{dV}{dx} \right|_{x=a}, \quad (11.23)$$

and thus for $x \simeq a$

$$p(x) \simeq \sqrt{2m\alpha(x-a)}. \quad (11.24)$$

Formally, the coordinate x can be considered as complex. Consider a circle in the complex plane centered at $x = a$ having a radius ρ . The radius $\rho > 0$ is assumed to be sufficiently large to ensure the validity of the WKB approximation outside it. On the other hand, it is also assumed to be sufficiently small to allow the employment of the approximation (11.24), namely, for any point on that circle

$$x = a + \rho e^{i\theta}, \quad (11.25)$$

where θ is real, it is assumed that

$$p(x) \simeq \sqrt{2m\alpha\rho} e^{i\theta/2}. \quad (11.26)$$

We consider below analytical continuation of the wavefunction given by Eq. (11.21) for the case $x > a$ into a region in the complex plane. Such a region must exclude the vicinity of the turning point $x = a$ where the WKB approximation breaks down and in addition it is required to be singly connected to allow analytical continuation. Two such regions are considered below, the first one, which is labeled as Θ_+ (see Fig. 11.1 (c)), excludes the circle $|x - a| \leq \rho$ and also excludes the negative imaginary line $x = a - ib$, whereas the second one, which is labeled as Θ_- (see Fig. 11.1 (d)), also excludes the circle $|x - a| \leq \rho$ and in addition excludes the positive imaginary line $x = a + ib$, where in both cases the parameter b is assumed to be real and positive.

To perform the tailoring it is convenient to define the term

$$I_{\pm}(\theta) = \pm \frac{i}{\hbar} \int_{\Gamma_{\theta}} dx' p,$$

where the integration trajectory Γ_{θ} [see Fig. 11.1 (b)] contains two sections, the first along the real axis from $x = a$ to $x = a + \rho$ and the second along the arc $x = a + \rho e^{i\theta'}$ from $\theta' = 0$ to $\theta' = \theta$. With the help of the approximation (11.26) one finds that

$$\begin{aligned} I_{\pm}(\theta) &= \pm \frac{i\sqrt{2m\alpha}}{\hbar} \left(\int_0^{\rho} d\rho' \sqrt{\rho'} + i\rho^{3/2} \int_0^{\theta} d\theta' e^{i3\theta'/2} \right) \\ &= \pm \frac{i\sqrt{2m\alpha}}{\hbar} \left(\frac{2}{3} \rho^{3/2} - i\rho^{3/2} \frac{2i(e^{\frac{3}{2}i\theta} - 1)}{3} \right) \\ &= \pm \frac{2i\sqrt{2m\alpha}\rho^{3/2}}{3\hbar} e^{\frac{3}{2}i\theta} \\ &= \frac{2\sqrt{2m\alpha}\rho^{3/2}}{3\hbar} e^{i(\pi(1 \mp \frac{1}{2}) + \frac{3}{2}\theta)}, \end{aligned} \tag{11.27}$$

thus

$$I_{\pm}(\pi) = \pm \frac{2\sqrt{2m\alpha}\rho^{3/2}}{3\hbar}, \tag{11.28}$$

$$I_{\pm}(-\pi) = \mp \frac{2\sqrt{2m\alpha}\rho^{3/2}}{3\hbar}. \tag{11.29}$$

The last result allows expressing the analytical continuation of the wavefunction given by Eq. (11.21) for the case $x > a$ and evaluate its value at the point $x = a - \rho$. For the case where the singly connected region Θ_+ (Θ_-) is employed, this is done using integration along the trajectory Γ_{π} ($\Gamma_{-\pi}$), and the result is labeled as $\psi_+(a - \rho)$ [$\psi_-(a - \rho)$]

$$\psi_+(a-\rho) = \frac{C_+ \exp\left(\frac{2\sqrt{2m\alpha\rho^{3/2}}}{3\hbar}\right) + C_- \exp\left(-\frac{2\sqrt{2m\alpha\rho^{3/2}}}{3\hbar}\right)}{(2m\alpha\rho)^{1/4} e^{i\pi/4}}, \quad (11.30)$$

$$\psi_-(a-\rho) = \frac{C_+ \exp\left(-\frac{2\sqrt{2m\alpha\rho^{3/2}}}{3\hbar}\right) + C_- \exp\left(\frac{2\sqrt{2m\alpha\rho^{3/2}}}{3\hbar}\right)}{(2m\alpha\rho)^{1/4} e^{-i\pi/4}}. \quad (11.31)$$

Note that the denominators of Eqs. (11.30) and (11.31) are evaluated by analytical continuation of the factor \sqrt{p} [see Eq. (11.26)] along the trajectories Γ_π and $\Gamma_{-\pi}$ respectively. On the other hand, according to Eq. (11.21) in the region $x < a$ one finds by integration along the real axis that

$$\psi(a-\rho) = \frac{C}{(2m\alpha\rho)^{1/4}} \exp\left(-\frac{2\sqrt{2m\alpha\rho^{3/2}}}{3\hbar}\right). \quad (11.32)$$

Comparing Eqs. (11.30) and (11.31) with Eq. (11.32) shows that for each of the two choices Θ_+ and Θ_- the analytical continuation yields one exponential term having the same form as the one in Eq. (11.32), and another one, which diverges in the limit $x \rightarrow -\infty$. Excluding the diverging terms one finds that continuity of the non diverging term requires that

$$C = \frac{C_+}{e^{-i\pi/4}} = \frac{C_-}{e^{i\pi/4}}, \quad (11.33)$$

and thus the tailored wavefunction is given by

$$\psi(x) = \begin{cases} \frac{C}{\sqrt{|p|}} \exp\left(\frac{1}{\hbar} \int_a^x dx' |p|\right) & x < a \\ \frac{2C}{\sqrt{p}} \cos\left(\frac{1}{\hbar} \int_a^x dx' p - \frac{\pi}{4}\right) & x > a \end{cases}. \quad (11.34)$$

The fact that analytical continuation of the wavefunction in the region $x < a$ along the trajectory Γ_π ($\Gamma_{-\pi}$) yields only the right to left (left to right) propagating term in the region $x > a$, and the other term is getting lost along the way, can be attributed to the limited accuracy of the WKB approximation. As can be seen from Eq. (11.27), along the integration trajectory Γ_θ near the point $\theta = \pm\pi/3$ one term becomes exponentially larger than the other, and consequently, within the accuracy of this approximation the small term gets lost.

It is important to keep in mind that the above result (11.34) is obtained by assuming a particular form for the solution in the region $x < a$, namely by assuming that in the classically forbidden region the coefficient of the exponentially diverging term vanishes. This tailoring role will be employed in the next section that deals with bound states in a classically accessible region between two turning points [see Fig. 11.2(a)]. On the other hand, a modified tailoring role will be needed when dealing with quantum tunneling. For this case, which will be discussed below, we seek a wave function having the form

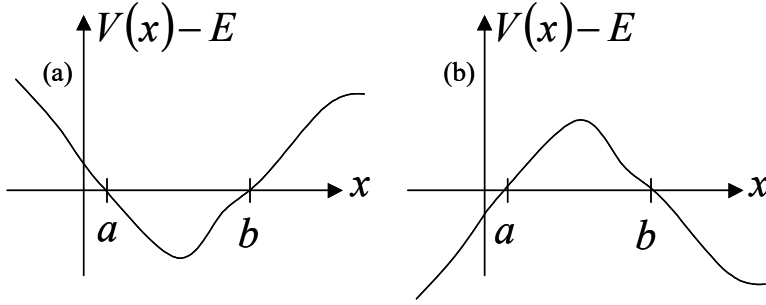

Fig. 11.2. The region $a \leq x \leq b$ bounded by the two turning points at $x = a$ and $x = b$ is classically accessible in panel (a), whereas it is classically forbidden in panel (b).

$$\psi(x) = \begin{cases} \frac{C_+}{\sqrt{|p|}} \exp\left(\frac{1}{\hbar} \int_a^x dx' |p|\right) + \frac{C_-}{\sqrt{|p|}} \exp\left(-\frac{1}{\hbar} \int_a^x dx' |p|\right) & x < a \\ \frac{C}{\sqrt{p}} \exp\left(\frac{i}{\hbar} \int_a^x dx' p + \frac{i\pi}{4}\right) & x > a \end{cases} \quad (11.35)$$

Thus, in this case only the term describing propagation from left to right is kept in the region $x > a$, and the coefficient of the other term in that region that describes propagation in the opposite direction is assumed to vanish. Using the same tailoring technique as in the previous case one finds that $C_+ = 0$ and $C_- = C$, and thus

$$\psi(x) = \begin{cases} \frac{C}{\sqrt{|p|}} \exp\left(-\frac{1}{\hbar} \int_a^x dx' |p|\right) & x < a \\ \frac{C}{\sqrt{p}} \exp\left(\frac{i}{\hbar} \int_a^x dx' p + \frac{i\pi}{4}\right) & x > a \end{cases} \quad (11.36)$$

11.3 Bohr-Sommerfeld Quantization Rule

Consider a classically accessible region $a \leq x \leq b$ bounded by two turning points at $x = a$ and $x = b$, namely, consider the case where $E > V(x)$ for $a \leq x \leq b$ and where $E < V(x)$ for $x < a$ and for $x > b$ [see Fig. 11.2(a)]. We seek a normalizable solution, thus the wave function in the classically forbidden regions $x < a$ and for $x > b$ is assumed to vanish in the limit $x \rightarrow \pm\infty$. Employing the tailoring rule (11.34) with respect to the turning point at $x = a$ yields the following wave function for the region $a \leq x \leq b$

$$\psi_a(x) = \frac{2C_a}{\sqrt{p}} \cos\left(\frac{1}{\hbar} \int_a^x dx' p - \frac{\pi}{4}\right), \quad (11.37)$$

where C_a is a constant. Similarly, employing the tailoring role (11.34) with respect to the turning point at $x = b$ yields

$$\psi_b(x) = \frac{2C_b}{\sqrt{p}} \cos\left(\frac{1}{\hbar} \int_x^b dx' p - \frac{\pi}{4}\right). \quad (11.38)$$

The requirement $\psi_a(x) = \psi_b(x)$ can be satisfied for any x in the region $a \leq x \leq b$ only if

$$\frac{1}{\hbar} \int_a^b dx' p = \frac{\pi}{2} + n\pi. \quad (11.39)$$

where n is integer. Alternatively, this result, which is known as Bohr-Sommerfeld quantization rule, can be expressed as

$$\frac{1}{2\pi\hbar} \oint dx' p = n + \frac{1}{2}, \quad (11.40)$$

where

$$\oint dx' p = 2 \int_a^b dx' p. \quad (11.41)$$

To normalize the wavefunction $\psi_a(x) = \psi_b(x)$ we assume that (a) only the accessible region $a \leq x \leq b$ contributes, since outside this region the wavefunction exponentially decays; and (b) in the limit of large n the cosine term rapidly oscillates and therefore the average of its squared value is approximately $1/2$. Applying these assumptions to $\psi_a(x)$, which is given by Eq. (11.37), implies that

$$1 \simeq \int_a^b dx' |\psi_a(x)|^2 \simeq 2|C_a|^2 \int_a^b \frac{dx'}{p}. \quad (11.42)$$

Note that the time period T of classical oscillations between the turning points $x = a$ and $x = b$ is given by

$$T = 2 \int_a^b \frac{dx'}{v}. \quad (11.43)$$

where $v(x) = p(x)/m$ is the local classical velocity. Thus, by choosing the pre-factor to be real, one finds that the normalized wavefunction is given by

$$\psi(x) = 2\sqrt{\frac{m}{pT}} \cos\left(\frac{1}{\hbar} \int_a^x dx' p - \frac{\pi}{4}\right). \quad (11.44)$$

The Bohr-Sommerfeld quantization rule (11.40) can be used to relate the classical time period T with the energy spacing $\Delta E = E_{n+1} - E_n$ between consecutive quantum eigenenergies. As can be seen from the validity condition of the WKB approximation (11.13), the integer n is required to be large to ensure the validity of Eq. (11.40). In this limit $\Delta E \ll E$, and thus by taking the derivative of Eq. (11.40) with respect to energy one finds that

$$\Delta E \oint dx' \left(\frac{\partial E}{\partial p} \right)^{-1} = 2\pi\hbar. \quad (11.45)$$

In classical mechanics $\partial E/\partial p$ is the velocity of the particle v , therefor

$$\oint dx' \left(\frac{\partial E}{\partial p} \right)^{-1} = T, \quad (11.46)$$

thus

$$\Delta E = \frac{2\pi\hbar}{T}. \quad (11.47)$$

11.4 Tunneling

In this case we consider a classical forbidden region $a \leq x \leq b$ bounded by two turning points at $x = a$ and $x = b$, namely, it is assumed that $E < V(x)$ for $a \leq x \leq b$ and $E > V(x)$ for $x < a$ and for $x > b$ [see Fig. 11.2(b)]. In classical mechanics a particle cannot penetrate into the potential barrier in the region $a \leq x \leq b$, however such a process is possible in quantum mechanics. Consider a solution having the form

$$\psi(x) = \begin{cases} \frac{1}{\sqrt{p}} \exp\left(\frac{i}{\hbar} \int_a^x dx' p\right) + \frac{r}{\sqrt{p}} \exp\left(-\frac{i}{\hbar} \int_a^x dx' p\right) & x < a \\ \frac{C_+}{\sqrt{|p|}} \exp\left(\frac{1}{\hbar} \int_b^x dx' |p|\right) + \frac{C_-}{\sqrt{|p|}} \exp\left(-\frac{1}{\hbar} \int_b^x dx' |p|\right) & a \leq x \leq b \\ \frac{t}{\sqrt{p}} \exp\left(\frac{i}{\hbar} \int_b^x dx' p + \frac{i\pi}{4}\right) & x > b \end{cases},$$

where we have introduced the transmission and reflection coefficients t and r respectively. Such a solution describes an incident wave of unit amplitude propagating in the region $x < a$ from left to right, a reflected wave having amplitude r in the same region, and a transmitted wave having amplitude t in the opposite side of the barrier $x > b$.

Employing the tailoring rule (11.36) yields $C_+ = 0$ and $C_- = t$. Moreover, employing the tailoring rule (11.34) and using the identity

$$\exp\left(-\frac{1}{\hbar} \int_b^x dx' |p|\right) = \tau^{-1/2} \exp\left(-\frac{1}{\hbar} \int_a^x dx' |p|\right), \quad (11.48)$$

where

$$\tau = \exp\left(-\frac{2}{\hbar} \int_a^b dx' |p|\right), \quad (11.49)$$

yield $|t| \tau^{-1/2} = 1$, thus the transmission probability is given by

$$|t|^2 = \tau = \exp\left(-\frac{2}{\hbar} \int_a^b dx' |p|\right). \quad (11.50)$$

It is important to keep in mind that this approximation is valid only when $\tau \ll 1$. One way of seeing this is by noticing that the second tailoring step, as can be seen from Eq. (11.34), also leads to the conclusion that $|r| = 1$. This apparently contradicts Eq. (11.50), which predicts a nonvanishing value for $|t|$, whereas current conservations, on the other hand, requires that $|t|^2 + |r|^2 = 1$ [see Eq. (4.276)]. This apparent contradiction can be attributed to limited accuracy of the WKB approximation, however, Eq. (11.50) can be considered to be a good approximation only provided that $\tau \ll 1$.

11.5 Problems

1. Use the Bohr-Sommerfeld quantization rule to approximately calculate the energy eigenvalues of a harmonic oscillator having angular frequency ω .
2. Consider a particle having mass m in a one dimension potential well $V(x)$ given by

$$V(x) = -\frac{V_0}{\cosh^2\left(\frac{x}{x_0}\right)}, \quad (11.51)$$

where both V_0 and x_0 are positive constants. Calculate the energies of the bound states using the WKB approximation.

3. Consider a particle having mass m in a one-dimensional potential $V(x)$ given by $V(x) = \eta|x|$, where η is a positive constant. Calculate the energy eigenvalues E_n in the WKB approximation.
4. Consider a particle having mass m in a one-dimensional potential $V(x)$ given by

$$V(x) = \begin{cases} \frac{m\omega^2}{2}(x+a)^2 & x < -a \\ 0 & |x| \leq a \\ \frac{m\omega^2}{2}(x-a)^2 & x > a \end{cases}, \quad (11.52)$$

where a and ω are positive constants. Calculate the energy eigenvalues E_n in the WKB approximation.

5. Consider a point particle having mass m moving in one dimension along the x axis under the influence of the potential $V(x)$, which is assumed to be negative, i.e. $V(x) < 0$. In addition, it is assumed that $\lim_{x \rightarrow \pm\infty} V(x) = 0$. Use the WKB approximation to estimate the number N_b of bound states (i.e. energy eigenstates having negative energy). Apply the general result for the case where

$$V(x) = -\frac{V_0}{\cosh^2\left(\frac{x}{x_0}\right)}, \quad (11.53)$$

where both V_0 and x_0 are positive constants.

6. Consider a particle having mass m confined by a one-dimensional potential $V(x)$, which is given by

$$V(x) = \begin{cases} \frac{m\omega^2}{2}x^2 & x > 0 \\ \infty & x \leq 0 \end{cases}, \quad (11.54)$$

where ω is a constant. Use the WKB approximation to calculate the energy eigenvalues.

7. Consider a point particle having mass m moving in one dimension under the influence of the potential $V(x') = V_0(x') + V_1(x')$, where $V_1(x') = \lambda\tilde{V}_1(x')$, and λ is positive. Let $E_n(\lambda)$ be the energy of the n 'th energy eigenvector. To first order in λ , the energy $E_n(\lambda)$ is expressed as $E_n(\lambda) = E_{n0} + \lambda\tilde{E}_{n1} + O(\lambda^2)$. Use the Bohr-Sommerfeld quantization rule to find an expression for the first order energy correction $E_{n1} = \lambda\tilde{E}_{n1}$.
8. Calculate the transmission probability τ of a particle having mass m and energy E through the potential barrier $V(x)$, which vanishes in the region $x < 0$ and which is given by $V(x) = U - ax$ in the region $x \geq 0$, where $a > 0$ and where $U > E$.
9. Consider a one-dimensional rectangular potential barrier of height U_b and width a given by

$$V(x') = \begin{cases} U_b & |x'| \leq \frac{a}{2} \\ 0 & |x'| > \frac{a}{2} \end{cases}. \quad (11.55)$$

Calculate using the WKB approximation the transmission probability τ for a particle of mass m and energy E to pass through the barrier. Compare with the exact result.

10. Calculate the transmission probability τ of a particle having mass m and energy E through the potential barrier $V(x) = -m\omega^2x^2/2$, where $\omega > 0$. Consider the general case without assuming $\tau \ll 1$.
11. Consider a particle having mass m moving in one dimension under the influence of the potential $V(x)$. The potential $V(x)$ is assumed to be an even function of position x , and a monotonically increasing function of $|x|$. All energy eigenvalues E_n , where n is an integer, are given. Employ the WKB approximation to calculate the potential $V(x)$. Verify your

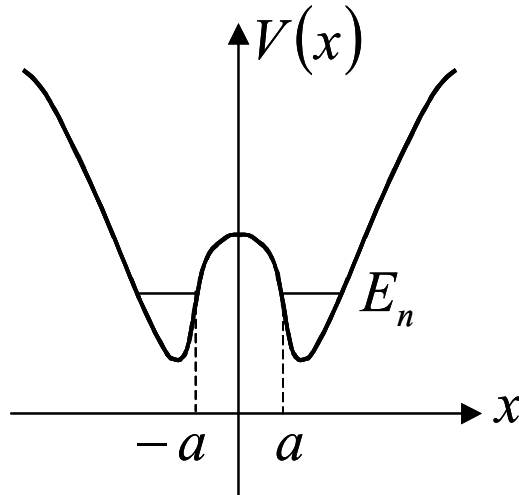

Fig. 11.3. Double well potential.

result by considering the case of a harmonic oscillator, for which $E_n = \hbar\omega(n + 1/2)$, and $V = m\omega^2 x^2/2$ where ω is a positive constant and n is a non negative integer.

12. Consider a particle having mass m moving in one dimension along the x axis under the influence of the potential $V(x)$. It is assumed that the energy eigenvalues E_n are given by

$$E_n = E_1 (1 + \log n) , \quad (11.56)$$

where E_1 is a constant, and n is a positive integer. Calculate the potential $V(x)$ using the WKB approximation.

13. Consider a particle having mass m moving in a one-dimensional double well potential (see Fig. 11.3), which is assumed to be symmetric, i.e. $V(x) = V(-x)$. In the limit where the barrier separating the two wells can be considered as impenetrable, each well is characterized by a set of eigenstates having eigenenergies $\{E_n\}$. To lowest nonvanishing order in the penetrability of the barrier calculate the eigenenergies of the system.
14. Employ the WKB approximation to derive the eigenenergies of the hydrogen atom.

11.6 Solutions

1. For a harmonic oscillator having mass m and energy E the momentum p is given by $p = \sqrt{2m(E - (1/2)m\omega^2 x^2)}$, and thus the Bohr-Sommerfeld

quantization rule (11.40) yields

$$\frac{1}{\pi\hbar} \int_{-x_T}^{x_T} dx' \sqrt{2m(E - (1/2)m\omega^2 x'^2)} = n + \frac{1}{2}, \quad (11.57)$$

where $x_T = \sqrt{2E/(m\omega^2)}$ (turning point at which $p = 0$), thus

$$\frac{2E}{\pi\hbar\omega} \int_0^1 dq \sqrt{\frac{1-q}{q}} = n + \frac{1}{2}, \quad (11.58)$$

hence [compare with Eq. (5.19)]

$$E_n = \hbar\omega \left(n + \frac{1}{2} \right). \quad (11.59)$$

2. The Bohr-Sommerfeld quantization rule (11.40) for this case reads

$$\frac{1}{\pi\hbar} \int_{-x_0 \cosh^{-1}\left(\sqrt{-\frac{V_0}{E}}\right)}^{x_0 \cosh^{-1}\left(\sqrt{-\frac{V_0}{E}}\right)} dx' \sqrt{2m \left(E + \frac{V_0}{\cosh^2\left(\frac{x'}{x_0}\right)} \right)} = n + \frac{1}{2}, \quad (11.60)$$

or

$$\frac{x_0 \sqrt{2mV_0}}{\pi\hbar} f\left(-\frac{E}{V_0}\right) = n + \frac{1}{2}, \quad (11.61)$$

where

$$f(\epsilon) = \int_{-\cosh^{-1}(\epsilon^{-1/2})}^{\cosh^{-1}(\epsilon^{-1/2})} ds \sqrt{\frac{1}{\cosh^2 s} - \epsilon}. \quad (11.62)$$

The following holds [note that the integrand in Eq. (11.62) vanishes at the end points of the integration region]

$$\begin{aligned} \frac{\partial f}{\partial \epsilon} &= - \int_{-\cosh^{-1}(\epsilon^{-1/2})}^{\cosh^{-1}(\epsilon^{-1/2})} ds \frac{\cosh s}{2\sqrt{1 - \epsilon \cosh^2 s}} \\ &= - \int_{-\sqrt{\frac{1-\epsilon}{\epsilon}}}^{\sqrt{\frac{1-\epsilon}{\epsilon}}} \frac{dq}{2\sqrt{1 - \epsilon(q^2 + 1)}} \\ &= - \frac{1}{2\sqrt{\epsilon}} \left[\arctan \frac{q\sqrt{\epsilon}}{\sqrt{1 - \epsilon q^2 - \epsilon}} \right]_{-\sqrt{\frac{1-\epsilon}{\epsilon}}}^{\sqrt{\frac{1-\epsilon}{\epsilon}}} \\ &= - \frac{\pi}{2\sqrt{\epsilon}}, \end{aligned} \quad (11.63)$$

and therefore [as can be seen from Eq. (11.62), $f(1) = 0$]

$$f(\epsilon) = \pi(1 - \sqrt{\epsilon}), \quad (11.64)$$

and thus

$$E_n = -V_0 \left(1 - \frac{\hbar(n + \frac{1}{2})}{x_0 \sqrt{2mV_0}} \right)^2. \quad (11.65)$$

3. The Bohr-Sommerfeld quantization rule (11.40) yields

$$\begin{aligned} n + \frac{1}{2} &= \frac{1}{\pi\hbar} \int_{-\frac{E_n}{\eta}}^{\frac{E_n}{\eta}} dx \sqrt{2m(E_n - \eta|x|)} \\ &= \frac{2\sqrt{2m\eta}}{\pi\hbar} \frac{2}{3} \left(\frac{E_n}{\eta} \right)^{\frac{3}{2}}, \end{aligned} \quad (11.66)$$

hence

$$E_n = \eta \left(\frac{3\pi\hbar(n + \frac{1}{2})}{4\sqrt{2m\eta}} \right)^{2/3}. \quad (11.67)$$

4. The Bohr-Sommerfeld quantization rule (11.40) yields

$$\begin{aligned} \pi\hbar \left(n + \frac{1}{2} \right) &= \int_{-a - \sqrt{\frac{2E_n}{m\omega^2}}}^{-a} dx \sqrt{2m \left(E_n - \frac{m\omega^2}{2} (x+a)^2 \right)} \\ &\quad + \int_{-a}^a dx \sqrt{2mE_n} \\ &\quad + \int_a^{a + \sqrt{\frac{2E_n}{m\omega^2}}} dx \sqrt{2m \left(E_n - \frac{m\omega^2}{2} (x-a)^2 \right)}, \end{aligned} \quad (11.68)$$

or

$$\begin{aligned}
 \pi\hbar\left(n + \frac{1}{2}\right) &= 2a\sqrt{2mE_n} + \int_{-\sqrt{\frac{2E_n}{m\omega^2}}}^{\sqrt{\frac{2E_n}{m\omega^2}}} dq \sqrt{2m\left(E_n - \frac{m\omega^2}{2}q^2\right)} \\
 &= 2\hbar\frac{a}{x_0}\sqrt{2\epsilon_n} + \hbar \int_{-\sqrt{2\epsilon_n}}^{\sqrt{2\epsilon_n}} d\eta \sqrt{2\epsilon_n - \eta^2} \\
 &= 2\hbar\frac{a}{x_0}\sqrt{2\epsilon_n} + 2\epsilon_n\hbar \int_{-1}^1 ds \sqrt{1 - s^2} \\
 &= \pi\hbar\left(\frac{2\sqrt{2\epsilon_n}}{\pi}\frac{a}{x_0} + \epsilon_n\right),
 \end{aligned} \tag{11.69}$$

where

$$\epsilon_n = \frac{E_n}{\hbar\omega}, \tag{11.70}$$

$$x_0 = \sqrt{\frac{\hbar}{m\omega}}, \tag{11.71}$$

hence

$$\epsilon_n = \left(-\frac{q}{2} + \frac{1}{2}\sqrt{q^2 + 4n + 2}\right)^2, \tag{11.72}$$

where

$$q = \frac{2\sqrt{2}}{\pi}\frac{a}{x_0}. \tag{11.73}$$

For $q \ll 1$ [compare with Eq. (5.19)]

$$E_n = \hbar\omega\left(n + \frac{1}{2}\right), \tag{11.74}$$

whereas for $q \gg 1$ [compare with Eq. (4.255), and note that the approximation $n + 1/2 \simeq n$ has been employed]

$$E_n = \hbar\omega\left(\frac{n}{q}\right)^2 = \frac{\pi^2\hbar^2 n^2}{2m(2a)^2}. \tag{11.75}$$

5. With the help of the Bohr-Sommerfeld quantization rule (11.40) one finds that the number of bound states is approximately given by

$$N_b = \frac{\sqrt{2m}}{\pi\hbar} \int_{-\infty}^{\infty} dx' \sqrt{-V(x')}. \tag{11.76}$$

For the case where $V(x)$ is given by Eq. (11.53) one has [compare with Eq. (11.65)]

$$N_b = \frac{\sqrt{2mV_0}}{\pi\hbar} \int_{-\infty}^{\infty} \frac{dx'}{\cosh\left(\frac{x'}{x_0}\right)} = \sqrt{\frac{V_0}{\frac{\hbar^2 x_0^{-2}}{2m}}} . \quad (11.77)$$

6. For this case, the classical accessible region $a \leq x \leq b$ is bounded by the turning points at $x = a = 0$ and the turning point at $x = b$, where $E = V(b)$, with E being the energy. The infinite wall at $x = a = 0$ yields the requirement that the wavefunction $\psi(x)$ vanishes at that point, and consequently the condition (11.37) is replaced by the condition $\psi(0) = 0$. Therefore, the Bohr-Sommerfeld quantization rule for the current case becomes [see Eq. (11.38)]

$$\frac{1}{\hbar} \int_0^b dx' p(x') = \left(n - \frac{1}{4}\right) \pi , \quad (11.78)$$

where n is integer and where

$$p(x') = \sqrt{2m \left(E - \frac{m\omega^2 x'^2}{2} \right)} , \quad (11.79)$$

thus

$$\frac{1}{\hbar} \int_0^{\sqrt{\frac{2E}{m\omega^2}}} dx' \sqrt{2m \left(E - \frac{m\omega^2 x'^2}{2} \right)} = \left(n - \frac{1}{4}\right) \pi , \quad (11.80)$$

hence [compare with Eq. (5.174)]

$$E_n = \hbar\omega \left(2n + \frac{3}{2} \right) . \quad (11.81)$$

7. Let

$$I_n(\lambda) = \int_{a(\lambda)}^{b(\lambda)} dx' p_n(\lambda) , \quad (11.82)$$

where $a(\lambda)$ and $b(\lambda)$ are the turning points, at which the n 'th state's momentum p_n vanishes. To first order in λ the momentum $p_n(x')$ is given by

$$\begin{aligned} p_n(x') &= \sqrt{2m(E_n - V(x'))} \\ &= p_{n0}(x') + \lambda \frac{\tilde{E}_{n1} - \tilde{V}_1(x)}{2p_{n0}(x')} + O(\lambda^2) , \end{aligned} \quad (11.83)$$

where $p_{n0}(x') = \sqrt{2m(E_{n0} - V_0(x'))}$ is the unperturbed momentum. The requirement $\partial I_n / \partial \lambda = 0$ [see the Bohr-Sommerfeld quantization rule (11.40)] yields (note that p_n vanishes at the turning points)

$$E_{n1} = \frac{\int_{a(0)}^{b(0)} dx' \frac{V_1(x')}{p_{n0}(x')}}{\int_{a(0)}^{b(0)} dx' \frac{1}{p_{n0}(x')}} , \quad (11.84)$$

or

$$E_{n1} = \frac{2 \int_{a(0)}^{b(0)} dx' \frac{V_1(x')}{v_{n0}(x')}}{T_n} , \quad (11.85)$$

where $v_{n0}(x') = m^{-1}p_{n0}(x')$ is the velocity, and where T_n , which is given by

$$T_n = 2 \int_{a(0)}^{b(0)} \frac{dx'}{v_{n0}(x')} , \quad (11.86)$$

is the classical period time [see Eq. (11.43)].

8. The classical turning points are $x = 0$ and $x = (U - E)/\alpha$. Thus with the help of Eq. (11.50) one finds that

$$\begin{aligned} \tau &= \exp \left(-\frac{2\sqrt{2m\alpha}}{\hbar} \int_0^{(U-E)/\alpha} dx \sqrt{\frac{U-E}{\alpha} - x} \right) \\ &= \exp \left(-\frac{4\sqrt{2m}}{3\hbar\alpha} (U-E)^{\frac{3}{2}} \right) . \end{aligned} \quad (11.87)$$

9. The exact result is given by [see Eq. (4.299)]

$$\tau_{\text{exact}} = \frac{1}{\cos^2 \kappa a + \frac{1}{4} \left(\frac{k}{\kappa} + \frac{\kappa}{k} \right)^2 \sin^2 \kappa a} , \quad (11.88)$$

where

$$\frac{\hbar^2 k^2}{2m} = E , \quad (11.89)$$

$$\frac{\hbar^2 \kappa^2}{2m} = E - U_b , \quad (11.90)$$

whereas the WKB approximation yields [see Eq. (11.50)]

$$\tau_{\text{WKB}} = \exp \left(-2\sqrt{-\kappa^2 a} \right) . \quad (11.91)$$

To compare the two results it is convenient to rewrite Eq. (11.88) as

$$\begin{aligned}
\tau_{\text{exact}} &= \frac{1}{1 + \left[\frac{1}{4} \left(\frac{k^2 + \kappa^2}{\kappa k} \right)^2 - 1 \right] \sin^2 \kappa a} \\
&= \frac{1}{1 + \frac{U_b^2}{4E(E-U_b)} \sin^2 \kappa a}.
\end{aligned} \tag{11.92}$$

When $\tau \ll 1$, i.e. when κ is pure imaginary and $\sqrt{-\kappa^2}a \gg 1$, the following holds (recall that $\sin(ix) = i \sinh x$)

$$\tau_{\text{exact}} \simeq \frac{16E(U_b - E)}{U_b^2} \exp\left(-2\sqrt{-\kappa^2}a\right). \tag{11.93}$$

10. The factor p/\hbar can be expressed as

$$\begin{aligned}
\frac{p(x)}{\hbar} &= \frac{\sqrt{2m\left(E + \frac{m\omega^2 x^2}{2}\right)}}{\hbar} = \\
&= \frac{x}{x_0^2} \sqrt{1 + \frac{2Ex_0^2}{E_0 x^2}},
\end{aligned} \tag{11.94}$$

where $x_0 = \sqrt{\hbar/m\omega}$ and where $E_0 = \hbar\omega$. For sufficiently large $|x|$, namely for $x^2 \gg Ex_0^2/E_0$, one has

$$\frac{p(x)}{\hbar} \simeq \frac{x}{x_0^2} + \frac{E}{E_0 x}, \tag{11.95}$$

where x is assumed to be positive. The corresponding WKB wavefunctions (11.17) in the same limit of large large $|x|$ are given (up to multiplication by a constant) by

$$\begin{aligned}
\varphi_{\pm}(x) &= \frac{1}{\sqrt{x_0 p/\hbar}} \exp\left(\pm \frac{i}{\hbar} \int^x dx' p(x')\right) \\
&= \frac{\exp\left(\pm \frac{i}{x_0^2} \int_0^x dx' x'\right) \exp\left(\pm i \frac{E}{E_0} \int_{x_0}^x \frac{dx'}{x'}\right)}{\left(\frac{x}{x_0^2}\right)^{1/2} \left(1 + \frac{2Ex_0^2}{E_0 x^2}\right)^{1/4}} \\
&\simeq \left(\frac{x}{x_0}\right)^{\pm i \frac{E}{E_0} - \frac{1}{2}} \exp\left(\pm \frac{ix^2}{2x_0^2}\right).
\end{aligned} \tag{11.96}$$

Consider a solution having the asymptotic form

$$\psi(x') = \begin{cases} \left(-\frac{x}{x_0}\right)^{-i\frac{E}{E_0}-\frac{1}{2}} \exp\left(-\frac{ix^2}{2x_0^2}\right) + r \left(-\frac{x}{x_0}\right)^{i\frac{E}{E_0}-\frac{1}{2}} \exp\left(\frac{ix^2}{2x_0^2}\right) & x \rightarrow -\infty \\ t \left(\frac{x}{x_0}\right)^{i\frac{E}{E_0}-\frac{1}{2}} \exp\left(\frac{ix^2}{2x_0^2}\right) & x \rightarrow \infty \end{cases}, \quad (11.97)$$

where t and r are transmission and reflection coefficients respectively, which can be related one to another by the technique of analytical continuation. Consider x as a complex variable

$$\frac{x}{x_0} = \rho e^{i\theta}, \quad (11.98)$$

where $\rho > 0$ and θ is real. The transmitted term in the limit $x \rightarrow \infty$ along the upper semicircle $x/x_0 = \rho e^{i\theta}$, where $0 \leq \theta \leq \pi$ is given by

$$t(\rho e^{i\theta})^{i\frac{E}{E_0}-\frac{1}{2}} \exp\left(\frac{i\rho^2 e^{2i\theta}}{2}\right), \quad (11.99)$$

thus for $\theta = \pi$ this term becomes identical to the reflected term at $x/x_0 = -\rho$, which is given by

$$r(\rho)^{i\frac{E}{E_0}-\frac{1}{2}} \exp\left(\frac{i\rho^2}{2}\right), \quad (11.100)$$

provided that

$$t(\rho e^{i\pi})^{i\frac{E}{E_0}-\frac{1}{2}} \exp\left(\frac{i\rho^2 e^{2i\pi}}{2}\right) = r(\rho)^{i\frac{E}{E_0}-\frac{1}{2}} \exp\left(\frac{i\rho^2}{2}\right), \quad (11.101)$$

or

$$-ite^{-\frac{\pi E}{E_0}} = r. \quad (11.102)$$

Moreover, current conservation requires that $|t|^2 + |r|^2 = 1$, thus

$$|t|^2 + \left|-ite^{-\frac{\pi E}{E_0}}\right|^2 = 1, \quad (11.103)$$

and therefor the transmission probability $\tau = |t|^2$ is given by

$$\tau = \frac{1}{1 + e^{-\frac{2\pi E}{E_0}}}. \quad (11.104)$$

As we have seen above, the analytical continuation of the transmitted term in the region $x \rightarrow \infty$ leads to the reflected term in the region $x \rightarrow -\infty$. What about the incident term in the region $x \rightarrow -\infty$ (the first term)? Note that this term (the incident one) becomes exponentially small compared with the reflected term in a section near $\theta = 3\pi/4$ along the upper semicircle [due to the exponential factors $\exp(\pm ix^2/2x_0^2)$]. Consequently, within the accuracy of the WKB approximation it does not contribute to the analytically continued value.

11. The Bohr-Sommerfeld quantization rule (11.40) can be expressed as

$$\frac{1}{\pi\hbar} \int_{-V^{-1}(E)}^{V^{-1}(E)} dx' \sqrt{2m(E - V(x'))} = n + \frac{1}{2}. \quad (11.105)$$

Taking the derivative with respect to n leads to (recall that the integrand vanishes at the integration end points)

$$\frac{\sqrt{m}}{\sqrt{2}\pi\hbar} \frac{dE}{dn} \int_{-V^{-1}(E)}^{V^{-1}(E)} \frac{dx'}{\sqrt{E - V(x')}} = 1, \quad (11.106)$$

or [recall that $V(x)$ is even]

$$f(E) = \int_0^E dV \frac{u(V)}{\sqrt{E - V}}, \quad (11.107)$$

where

$$f(E) = \frac{\pi\hbar}{\sqrt{2m}} \left(\frac{dE}{dn} \right)^{-1}, \quad (11.108)$$

and where

$$u(V) = \frac{dx'}{dV}. \quad (11.109)$$

The unknown function $u(V)$ can be expressed in terms of the given function $f(E)$ by solving Eq. (11.107), which is known as the Abel integral equation. Applying the Laplace transform to Eq. (11.107) and employing the convolution theorem for the right hand side of Eq. (11.107) lead to

$$\begin{aligned} \int_0^\infty dE e^{-TE} f(E) &= \int_0^\infty dE e^{-TE} \int_0^E dV \frac{u(V)}{\sqrt{E - V}} \\ &= \int_V^\infty dE e^{-TE} \int_0^\infty dV \frac{u(V)}{\sqrt{E - V}} \\ &= \int_0^\infty dE' \frac{e^{-TE'}}{\sqrt{E'}} \int_0^\infty dV e^{-TV} u(V) \\ &= \sqrt{\frac{\pi}{T}} \int_0^\infty dV e^{-TV} u(V). \end{aligned} \quad (11.110)$$

Applying the inverse Laplace transform to

$$\int_0^\infty dV e^{-TV} u(V) = \frac{T}{\sqrt{\pi}} \frac{1}{\sqrt{T}} \int_0^\infty dE e^{-TE} f(E), \quad (11.111)$$

and employing again the convolution theorem yield

$$u(V) = \frac{1}{\pi} \frac{d}{dV} \int_0^V dE \frac{f(E)}{\sqrt{V-E}}, \quad (11.112)$$

and thus [see Eqs. (11.108) and (11.109)]

$$x(V) = \frac{\hbar}{\sqrt{2m}} \int_0^V \frac{dE}{\left(\frac{dE}{dn}\right) \sqrt{V-E}}, \quad (11.113)$$

For the case $E_n = \hbar\omega(n + 1/2)$ one has

$$x(V) = \frac{\hbar}{\sqrt{2m}} \int_0^V \frac{dE}{\hbar\omega\sqrt{V-E}} = \frac{1}{\omega} \sqrt{\frac{2V}{m}}, \quad (11.114)$$

and thus

$$V = \frac{m\omega^2 x^2}{2}. \quad (11.115)$$

12. With the help of Eq. (11.113) one finds that in the WKB approximation the potential $V(x)$ is given by

$$x(V) = \frac{\hbar}{\sqrt{2m}} \int_{V_0}^V \frac{dE}{\frac{dE}{dn} \sqrt{V-E}}, \quad (11.116)$$

where $V(0) = V_0$, hence the dimensionless position $X = x(V)/x_0$, where $x_0 = \hbar\sqrt{\pi/(2mE_1)}$, is given by [note that $dE/dn = E_1/n = E_1 \exp(1 - E/E_1)$]

$$X = \operatorname{erf} \left(\sqrt{\frac{V-V_0}{E_1}} \right) \exp \left(\frac{V}{E_1} - 1 \right). \quad (11.117)$$

For $V - V_0 \ll E_1$ [note that $\operatorname{erf}(x) = (2/\sqrt{\pi})x + O(x^3)$]

$$V = V_0 + E_1 \frac{\pi e^{-2\left(\frac{V_0}{E_1}-1\right)} X^2}{4}, \quad (11.118)$$

whereas for $V - V_0 \gg E_1$ [note that $\lim_{x \rightarrow \infty} \operatorname{erf}(x) = 1$]

$$V = E_1 (1 + \log X). \quad (11.119)$$

13. Consider one of the single-well eigenenergies E_n . The associated eigenstate corresponding to the left well is labeled as $|n, L\rangle$ and the one corresponding to the right well as $|n, R\rangle$. The effect of finite penetrability of the barrier can be evaluated using time independent perturbation theory for the degenerate case [see Eq. (9.38)]. For the unperturbed case, where the barrier separating the two wells can be considered as impenetrable, the level E_n is doubly degenerate, and the corresponding eigen space

is spanned by the vectors $\{|n, L\rangle, |n, R\rangle\}$. The projection of the Hamiltonian of the system $\mathcal{H} = p^2/2m + V$ on this eigen space is represented by the 2×2 matrix H_n , which is given by

$$H_n = \begin{pmatrix} \langle n, L | \mathcal{H} | n, L \rangle & \langle n, L | \mathcal{H} | n, R \rangle \\ \langle n, R | \mathcal{H} | n, L \rangle & \langle n, R | \mathcal{H} | n, R \rangle \end{pmatrix}. \quad (11.120)$$

Employing the approximations

$$\mathcal{H} |n, L\rangle \simeq E_n |n, L\rangle, \quad (11.121)$$

$$\mathcal{H} |n, R\rangle \simeq E_n |n, R\rangle, \quad (11.122)$$

one finds that

$$H_n = E_n \begin{pmatrix} 1 & \gamma \\ \gamma^* & 1 \end{pmatrix}, \quad (11.123)$$

where

$$\gamma = \langle n, L | n, R \rangle, \quad (11.124)$$

or in the coordinate representation

$$\gamma = \int_{-\infty}^{\infty} dx \varphi_{n,L}^*(x) \varphi_{n,R}(x), \quad (11.125)$$

where $\varphi_{n,L}(x)$ and $\varphi_{n,R}(x)$ are the wavefunctions of the states $|n, L\rangle$ and $|n, R\rangle$ respectively, i.e.

$$\varphi_{n,L}(x) = \langle x | n, L \rangle, \quad (11.126)$$

$$\varphi_{n,R}(x) = \langle x | n, R \rangle. \quad (11.127)$$

The main contribution to the overlap integral (11.125) comes from the classically forbidden region $|x| \leq a$, where $x = \pm a$ are turning points (i.e., $E_n = V(a) = V(-a)$). With the help of Eq. (11.36) one finds that

$$\gamma \simeq \int_{-a}^a dx \frac{|C|^2 \exp\left(-\frac{1}{\hbar} \int_{-a}^x dx' |p|\right) \exp\left(-\frac{1}{\hbar} \int_x^a dx' |p|\right)}{|p|} \quad (11.128)$$

$$= |C|^2 \exp\left(-\frac{1}{\hbar} \int_{-a}^a dx' |p|\right) \int_{-a}^a \frac{dx}{|p|}, \quad (11.129)$$

$$(11.130)$$

where C is the normalization factor of the WKB wavefunction, which is approximately given by $C = 2\sqrt{m/T}$ (T is the time period of classical

oscillations of a particle having energy E_n in a well) in the limit of large n [see Eq. (11.44)], thus

$$\gamma \simeq \frac{4 \int_{-a}^a \frac{dx}{|p/m|}}{T} \exp \left(-\frac{1}{\hbar} \int_{-a}^a dx' |p| \right). \quad (11.131)$$

Finally, By diagonalizing the matrix H_n one finds that the two eigenenergies are $E_n (1 \pm \gamma)$.

14. The radial equation for the case of hydrogen is given by [see Eq. (7.61)]

$$\left(\frac{-\hbar^2}{2\mu} \frac{d^2}{dr^2} + V_{\text{eff}}(r) \right) u_{kl}(r) = E_{kl} u_{kl}(r), \quad (11.132)$$

where $\mu \simeq m_e$ is the reduced mass (m_e is the electron's mass), and where

$$V_{\text{eff}}(r) = -\frac{e^2}{r} + \frac{l(l+1)\hbar^2}{2\mu r^2}. \quad (11.133)$$

The eigenenergies E_{kl} are calculated using the Bohr-Sommerfeld quantization rule (11.40)

$$\frac{1}{\pi\hbar} \int_{r_1}^{r_2} dr \sqrt{2\mu(E_{kl} - V_{\text{eff}}(r))} = k + \frac{1}{2}. \quad (11.134)$$

where k is required to be an integer. The points $r_{1,2}$ are classical turning points that satisfy

$$E_{kl} = V_{\text{eff}}(r_{1,2}). \quad (11.135)$$

Using the notation

$$\rho_{1,2} = \frac{r_{1,2}}{a_0}, \quad (11.136)$$

$$\varepsilon = -\frac{E_{kl}}{E_I}, \quad (11.137)$$

where

$$a_0 = \frac{\hbar^2}{\mu e^2} \quad (11.138)$$

is the Bohr's radius and where

$$E_I = \frac{\mu e^4}{2\hbar^2} \quad (11.139)$$

is the ionization energy, Eq. (11.135) becomes

$$\varepsilon = \frac{2}{\rho} - \frac{l(l+1)}{\rho^2}, \quad (11.140)$$

thus

$$\rho_{1,2} = \frac{1}{\varepsilon} \left(1 \pm \sqrt{1 - l(l+1)\varepsilon} \right). \quad (11.141)$$

Similarly Eq. (11.134) becomes

$$\int_{\rho_1}^{\rho_2} d\rho \sqrt{\frac{2}{\rho} - \frac{l(l+1)}{\rho^2} - \varepsilon} = \pi \left(k + \frac{1}{2} \right), \quad (11.142)$$

or

$$\sqrt{\varepsilon} I = \pi \left(k + \frac{1}{2} \right), \quad (11.143)$$

where the integral I , which is given by

$$I = \int_{\rho_1}^{\rho_2} d\rho \frac{\sqrt{(\rho - \rho_1)(\rho_2 - \rho)}}{\rho}, \quad (11.144)$$

can be calculated using the residue theorem

$$I = \pi \frac{\rho_1 + \rho_2}{2} \left(1 - \sqrt{\frac{4\rho_1\rho_2}{(\rho_1 + \rho_2)^2}} \right). \quad (11.145)$$

Thus the quantization condition (11.143) becomes

$$\varepsilon = -\frac{E_{kl}}{E_1} = \frac{1}{\left(\sqrt{l(l+1)} + k + \frac{1}{2} \right)^2}. \quad (11.146)$$

Comparing with the exact result (7.84) shows that the WKB result is a good approximation provided that the quantum numbers are large.

12. Path Integration

In this chapter, which is mainly based on Ref. [4], the technique of Feynman's path integration is briefly reviewed.

12.1 Charged Particle in Electromagnetic Field

Consider a point particle having mass m and charge q moving under the influence of electric field \mathbf{E} and magnetic field \mathbf{B} , which are related to the scalar potential φ and to the vector potential \mathbf{A} by

$$\mathbf{E} = -\nabla\varphi - \frac{1}{c}\frac{\partial\mathbf{A}}{\partial t}, \quad (12.1)$$

and

$$\mathbf{B} = \nabla \times \mathbf{A}. \quad (12.2)$$

The classical Lagrangian of the system is given by Eq. (1.43)

$$\mathcal{L} = \frac{1}{2}m\dot{\mathbf{r}}^2 - q\varphi + \frac{q}{c}\mathbf{A} \cdot \dot{\mathbf{r}}, \quad (12.3)$$

and the classical Hamiltonian is given by Eq. (1.62)

$$\mathcal{H} = \frac{(\mathbf{p} - \frac{q}{c}\mathbf{A})^2}{2m} + q\varphi. \quad (12.4)$$

The solution of the Euler Lagrange equations (1.8) yields the classical equation of motion of the system, which is given by Eq. (1.60)

$$m\ddot{\mathbf{r}} = q \left(\mathbf{E} + \frac{1}{c}\dot{\mathbf{r}} \times \mathbf{B} \right). \quad (12.5)$$

In what follows, we consider for simplicity the case where both φ and \mathbf{A} are time independent. For this case \mathcal{H} becomes time independent, and thus the quantum dynamics is governed by the time evolution operator, which is given by Eq. (4.9)

$$u(t) = \exp\left(-\frac{i\mathcal{H}t}{\hbar}\right). \quad (12.6)$$

The propagator $K(\mathbf{r}'_b, t; \mathbf{r}'_a)$ is defined by

$$K(\mathbf{r}'_b, t; \mathbf{r}'_a) = \langle \mathbf{r}'_b | u(t) | \mathbf{r}'_a \rangle, \quad (12.7)$$

where $|\mathbf{r}'\rangle$ denotes a common eigenvector of the position operators x , y , and z with vector of eigenvalues $\mathbf{r}' = (x', y', z')$. As can be seen from the definition, the absolute value squared of the propagator $K(\mathbf{r}'_b, t; \mathbf{r}'_a)$ is the probability distribution function to find the particle at point \mathbf{r}'_b at time t given that it was initially localized at point \mathbf{r}'_a at time $t = 0$.

Dividing the time interval $(0, t)$ into N sections of equal duration allows expressing the time evolution operator as

$$u(t) = \left[u\left(\frac{t}{N}\right) \right]^N. \quad (12.8)$$

The identity operator in the position representation [see Eq. (3.65)] is given by

$$1_r = \int d^3\mathbf{r}' |\mathbf{r}'\rangle \langle \mathbf{r}'|. \quad (12.9)$$

Inserting 1_r between any two factors in Eq. (12.8) and using the notation

$$\mathbf{r}'_a = \mathbf{r}'_0, \quad (12.10)$$

$$\mathbf{r}'_b = \mathbf{r}'_N, \quad (12.11)$$

$$\epsilon = \frac{t}{N}, \quad (12.12)$$

one finds that

$$\begin{aligned} K(\mathbf{r}'_b, t; \mathbf{r}'_a) &= \langle \mathbf{r}'_N | u(\epsilon) u(\epsilon) u(\epsilon) \times \cdots \times u(\epsilon) | \mathbf{r}'_0 \rangle \\ &= \int d^3\mathbf{r}'_1 \int d^3\mathbf{r}'_2 \times \cdots \times \int d^3\mathbf{r}'_{N-1} \\ &\times \langle \mathbf{r}'_N | u(\epsilon) | \mathbf{r}'_{N-1} \rangle \langle \mathbf{r}'_{N-1} | u(\epsilon) | \mathbf{r}'_{N-2} \rangle \langle \mathbf{r}'_{N-2} | u(\epsilon) \times \cdots \times | \mathbf{r}'_1 \rangle \langle \mathbf{r}'_1 | u(\epsilon) | \mathbf{r}'_0 \rangle, \end{aligned} \quad (12.13)$$

thus

$$K(\mathbf{r}'_b, t; \mathbf{r}'_a) = \prod_{n=1}^{N-1} \int d^3\mathbf{r}'_n \prod_{m=0}^{N-1} K(\mathbf{r}'_{m+1}, \epsilon; \mathbf{r}'_m). \quad (12.14)$$

In what follows the limit $N \rightarrow \infty$ will be taken, and therefore it is sufficient to calculate the infinitesimal propagator $K(\mathbf{r}'_{m+1}, \epsilon; \mathbf{r}'_m)$ to first order only in ϵ .

With the help of the relation (12.121), which is given by

$$e^{\epsilon(A+B)} = e^{\epsilon A} e^{\epsilon B} + O(\epsilon^2) , \quad (12.15)$$

one has

$$\begin{aligned} u(\epsilon) &= \exp\left(-\frac{i\mathcal{H}\epsilon}{\hbar}\right) \\ &= \exp\left(-\frac{i\epsilon\left(\mathbf{p}-\frac{q}{c}\mathbf{A}\right)^2}{2m\hbar}\right) \exp\left(-\frac{i\epsilon q\varphi}{\hbar}\right) + O(\epsilon^2) . \end{aligned} \quad (12.16)$$

Equation (12.123), which is given by

$$\exp\left(-\frac{i\epsilon\mathbf{V}^2}{2m\hbar}\right) = \frac{1}{(2\pi i)^{3/2}} \int d^3\mathbf{r}' \exp\left(\frac{i\mathbf{r}'^2}{2} - i\sqrt{\frac{\epsilon}{m\hbar}}\mathbf{V}\cdot\mathbf{r}'\right) , \quad (12.17)$$

allows expressing the first term in Eq. (12.16) as

$$\exp\left(-\frac{i\epsilon\left(\mathbf{p}-\frac{q}{c}\mathbf{A}\right)^2}{2m\hbar}\right) = \frac{1}{(2\pi i)^{3/2}} \int d^3\mathbf{r}' \exp\left(\frac{i\mathbf{r}'^2}{2} - i\sqrt{\frac{\epsilon}{m\hbar}}\left(\mathbf{p}-\frac{q}{c}\mathbf{A}\right)\cdot\mathbf{r}'\right) . \quad (12.18)$$

Moreover, with the help of Eq. (12.122), which is given by

$$e^{\epsilon(A+B)} = e^{\epsilon B/2} e^{\epsilon A} e^{\epsilon B/2} + O(\epsilon^3) , \quad (12.19)$$

one finds that

$$\begin{aligned} &\exp\left(-i\sqrt{\frac{\epsilon}{m\hbar}}\left(\mathbf{p}-\frac{q}{c}\mathbf{A}\right)\cdot\mathbf{r}'\right) \\ &= \exp\left(i\sqrt{\frac{\epsilon}{m\hbar}}\frac{q}{c}\frac{\mathbf{A}\cdot\mathbf{r}'}{2}\right) \exp\left(-i\sqrt{\frac{\epsilon}{m\hbar}}\mathbf{p}\cdot\mathbf{r}'\right) \exp\left(i\sqrt{\frac{\epsilon}{m\hbar}}\frac{q}{c}\frac{\mathbf{A}\cdot\mathbf{r}'}{2}\right) + O(\epsilon^{3/2}) . \end{aligned} \quad (12.20)$$

Combining these results yields

$$\begin{aligned} K(\mathbf{r}'_{m+1}, \epsilon; \mathbf{r}'_m) &= \langle \mathbf{r}'_{m+1} | u(\epsilon) | \mathbf{r}'_m \rangle \\ &= \frac{1}{(2\pi i)^{3/2}} \int d^3\mathbf{r}' \exp\left(\frac{i\mathbf{r}'^2}{2}\right) \exp\left(i\sqrt{\frac{\epsilon}{m\hbar}}\frac{q}{c}\frac{[\mathbf{A}(\mathbf{r}'_m) + \mathbf{A}(\mathbf{r}'_{m+1})]\cdot\mathbf{r}'}{2}\right) \\ &\quad \times \exp\left(-\frac{i\epsilon q\varphi(\mathbf{r}'_m)}{\hbar}\right) \langle \mathbf{r}'_{m+1} | \exp\left(-i\sqrt{\frac{\epsilon}{m\hbar}}\mathbf{p}\cdot\mathbf{r}'\right) | \mathbf{r}'_m \rangle \\ &\quad + O(\epsilon^{3/2}) . \end{aligned} \quad (12.21)$$

In the next step the identity operator in the momentum representation [see Eq. (3.71)], which is given by

$$1_{\mathbf{p}} = \int d^3\mathbf{p}' |\mathbf{p}'\rangle \langle \mathbf{p}'| , \quad (12.22)$$

is inserted to the left of the ket vector $|\mathbf{r}'_m\rangle$. With the help of Eq. (3.75), which is given by

$$\langle \mathbf{r}' | \mathbf{p}' \rangle = \frac{1}{(2\pi\hbar)^{3/2}} \exp\left(\frac{i\mathbf{p}' \cdot \mathbf{r}'}{\hbar}\right) , \quad (12.23)$$

one finds that

$$\begin{aligned} & \langle \mathbf{r}'_{m+1} | \exp\left(-i\sqrt{\frac{\epsilon}{m\hbar}} \mathbf{p} \cdot \mathbf{r}'\right) | \mathbf{r}'_m \rangle \\ &= \frac{1}{(2\pi\hbar)^3} \int d^3\mathbf{p}' \exp\left(\frac{i\mathbf{p}' \cdot (\mathbf{r}'_{m+1} - \mathbf{r}'_m)}{\hbar}\right) \exp\left(-i\sqrt{\frac{\epsilon}{m\hbar}} \mathbf{p}' \cdot \mathbf{r}'\right) . \end{aligned} \quad (12.24)$$

Thus, by using Eq. (3.84), which is given by

$$\frac{1}{(2\pi\hbar)^3} \int d^3\mathbf{p}' \exp\left(\frac{i\mathbf{p}' \cdot \mathbf{r}'}{\hbar}\right) = \delta(\mathbf{r}') , \quad (12.25)$$

one finds that

$$\langle \mathbf{r}'_{m+1} | \exp\left(-i\sqrt{\frac{\epsilon}{m\hbar}} \mathbf{p} \cdot \mathbf{r}'\right) | \mathbf{r}'_m \rangle = \delta\left(\mathbf{r}'_{m+1} - \mathbf{r}'_m - \sqrt{\frac{\epsilon\hbar}{m}} \mathbf{r}'\right) , \quad (12.26)$$

and thus

$$K(\mathbf{r}'_{m+1}, \epsilon; \mathbf{r}'_m) = \left(\frac{m}{2\pi i \epsilon \hbar}\right)^{3/2} \exp\left(\frac{i\epsilon}{\hbar} L_m\right) + O(\epsilon^{3/2}) , \quad (12.27)$$

where

$$L_m = \frac{m \left(\frac{\mathbf{r}'_{m+1} - \mathbf{r}'_m}{\epsilon}\right)^2}{2} - q\varphi(\mathbf{r}'_m) + \frac{q}{c} \frac{\mathbf{A}(\mathbf{r}'_m) + \mathbf{A}(\mathbf{r}'_{m+1})}{2} \cdot \frac{\mathbf{r}'_{m+1} - \mathbf{r}'_m}{\epsilon} . \quad (12.28)$$

Comparing Eq. (12.28) with the classical Lagrangian of the system, which is given by Eq. (1.43)

$$\mathcal{L} = \frac{1}{2} m \dot{\mathbf{r}}^2 - q\varphi + \frac{q}{c} \mathbf{A} \cdot \dot{\mathbf{r}} , \quad (12.29)$$

shows that L_m is nothing but the Lagrangian at point \mathbf{r}'_m

$$L_m = \mathcal{L}(\mathbf{r}'_m) . \quad (12.30)$$

As we have discussed above, the terms of order $\epsilon^{3/2}$ in Eq. (12.27) are not expected to contribute to $K(\mathbf{r}'_b, t; \mathbf{r}'_a)$ in the limit of $N \rightarrow \infty$. By ignoring these terms Eq. (12.14) becomes

$$K(\mathbf{r}'_b, t; \mathbf{r}'_a) = \lim_{N \rightarrow \infty} \left(\frac{Nm}{2\pi i \hbar} \right)^{N/2} \prod_{n=1}^{N-1} \int d^3 \mathbf{r}'_n \exp \left(\frac{i}{\hbar} \frac{t}{N} \sum_{m=0}^{N-1} \mathcal{L}(\mathbf{r}'_m) \right) . \quad (12.31)$$

Recall that the action in classical physics [see Eq. (1.4)] associated with a given path is given by

$$S = \int dt \mathcal{L} . \quad (12.32)$$

Thus, by defining the integral operator

$$\int_{\mathbf{r}'_a}^{\mathbf{r}'_b} \mathcal{D}[\mathbf{r}'(t)] = \lim_{N \rightarrow \infty} \left(\frac{Nm}{2\pi i \hbar} \right)^{N/2} \prod_{n=1}^{N-1} \int d^3 \mathbf{r}'_n , \quad (12.33)$$

the propagator $K(\mathbf{r}'_b, t; \mathbf{r}'_a)$ can be written as

$$K(\mathbf{r}'_b, t; \mathbf{r}'_a) = \int_{\mathbf{r}'_a}^{\mathbf{r}'_b} \mathcal{D}[\mathbf{r}'(t)] \exp \left(\frac{i}{\hbar} S_{\mathbf{r}'(t)} \right) , \quad (12.34)$$

where

$$S_{\mathbf{r}'(t)} = \int_0^t dt \mathcal{L}[\mathbf{r}'(t)] . \quad (12.35)$$

Equation (12.34), which is known as Feynman's path integral, expresses the propagator $K(\mathbf{r}'_b, t; \mathbf{r}'_a)$ in terms of all possible paths $\mathbf{r}'(t)$ satisfying $\mathbf{r}'(0) = \mathbf{r}'_a$ and $\mathbf{r}'(t) = \mathbf{r}'_b$, where each path $\mathbf{r}'(t)$ contributes a phase factor given by $\exp(iS_{\mathbf{r}'(t)}/\hbar)$, where $S_{\mathbf{r}'(t)}$ is the classical action of the path $\mathbf{r}'(t)$.

A note regarding notation: In the above derivation of Eq. (12.34) eigenvalues and eigenvectors were denoted with prime (e.g., \mathbf{r}' , $|\mathbf{r}'\rangle$, $\langle \mathbf{r}'|$, \mathbf{p}') to make them distinguishable from the corresponding operators (e.g., \mathbf{r} and \mathbf{p}). This distinction is no longer needed for the rest of this chapter, since no quantum operators are used to evaluate path integrals, and therefore, to make the notation less cumbersome, we omit the prime notation.

12.2 Classical Limit

Recall that the Hamilton's principle of least action states that the path taken by a classical system is the one for which the action S obtains a local minimum. This implies that for any infinitesimal change in the path the resultant

change in the action δS vanishes (i.e., $\delta S = 0$). As we have seen in chapter 1, this principle leads to Lagrange's equations of motion (1.8), which are given by

$$\frac{d}{dt} \frac{\partial \mathcal{L}}{\partial \dot{q}_n} = \frac{\partial \mathcal{L}}{\partial q_n}. \quad (12.36)$$

While in classical mechanics a definite path is associated with the system's dynamics, in quantum mechanics all possible paths are included in Feynman's path integral. However, as we show below, in the classical limit the dominant contribution to the path integral comes only from paths near the classical one. The classical limit is defined to be the limit where the Planck's constant approaches zero $\hbar \rightarrow 0$. In this limit the exponent $\exp(iS/\hbar)$ in the path integral rapidly oscillates, and consequently contributions from neighboring paths tend to cancel each other. However, near the classical path, such 'averaging out' does not occur since according to the principle of least action $\delta S = 0$ for the classical path. Consequently, constructive interference between neighboring paths is possible near the classical path, and as a result the main contribution to the path integral in the classical limit comes from the paths near the classical path.

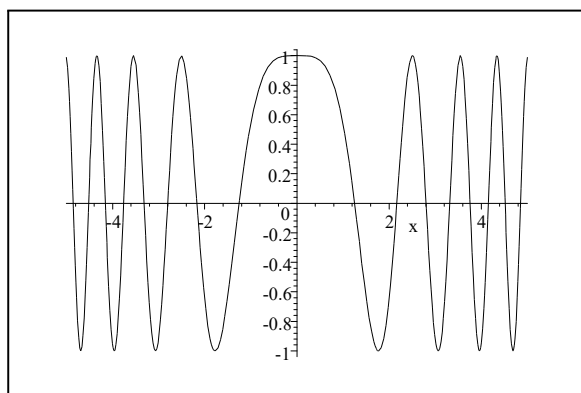

Graphical demonstration of the stationary phase approximation. The plot shows the function $\cos(\alpha x^2)$ for the case $\alpha = 1$. According to the stationary phase approximation, in the limit $\alpha \rightarrow \infty$, the main contribution to the integral $\int_{-\infty}^{\infty} dx \cos(\alpha x^2)$ comes from the region near the point $x = 0$, where $d(x^2)/dx = 0$.

12.3 Aharonov-Bohm Effect

Using Eq. (1.43) for the classical Lagrangian of a charged particle in stationary electromagnetic field one finds that the classical action (12.35) associated with a path $\mathbf{r}(t)$ in the time interval $(0, t)$ is given by

$$S = \int_0^t dt \left(\frac{1}{2} m \dot{\mathbf{r}}^2 - q\varphi + \frac{q}{c} \mathbf{A} \cdot \dot{\mathbf{r}} \right). \quad (12.37)$$

Consider first the case where the vector potential vanishes, i.e. $\mathbf{A} = 0$. For this case, the system is said to be conservative, and therefore, as we have seen in chapter 1 [see Eq. (1.29)], the energy of the system

$$E = \frac{1}{2} m \dot{\mathbf{r}}^2 + q\varphi \quad (12.38)$$

is a constant of the motion (see exercise 5 below). In terms of E the action S (12.37), which is labeled as S_0 for this case where $\mathbf{A} = 0$, can be expressed as

$$\begin{aligned} S_0 &= \int_0^t dt \left(\frac{1}{2} m \dot{\mathbf{r}}^2 - q\varphi \right) \\ &= \int_0^t dt (-E + m \dot{\mathbf{r}}^2) \\ &= -Et + m \int_{\mathbf{r}_a}^{\mathbf{r}_b} d\mathbf{r} \cdot \dot{\mathbf{r}}. \end{aligned} \quad (12.39)$$

where $\mathbf{r}_a = \mathbf{r}(0)$ and $\mathbf{r}_b = \mathbf{r}(t)$. Employing Eq. (12.38) again allows rewriting S_0 as

$$S_0 = -Et + \int_{\mathbf{r}_a}^{\mathbf{r}_b} d\mathbf{r} p(\mathbf{r}), \quad (12.40)$$

where $p(\mathbf{r})$ is the local classical momentum

$$p(\mathbf{r}) = \sqrt{2m(E - q\varphi(\mathbf{r}))}. \quad (12.41)$$

The phase factor in the path integral corresponding to S_0 is given by

$$\exp\left(\frac{iS_0}{\hbar}\right) = \exp\left(-\frac{iEt}{\hbar}\right) \exp\left(\frac{i}{\hbar} \int_{\mathbf{r}_a}^{\mathbf{r}_b} d\mathbf{r} p(\mathbf{r})\right). \quad (12.42)$$

Note the similarity between the second factor in the above equation and between the WKB wavefunction [see Eq. (11.17)]. In the general case, where \mathbf{A} can be nonzero, the phase factor in the path integral becomes [see Eq. (12.37)]

$$\exp\left(\frac{iS}{\hbar}\right) = \exp\left(\frac{iS_0}{\hbar}\right) \exp\left(\frac{iq}{\hbar c} \int_{\mathbf{r}_a}^{\mathbf{r}_b} d\mathbf{r} \cdot \mathbf{A}\right). \quad (12.43)$$

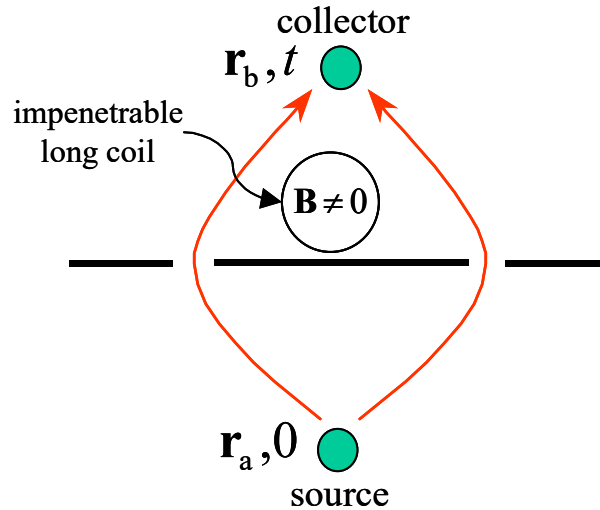

Fig. 12.1. Two-slit interference experiment with a very long impenetrable cylinder placed near the gap between the slits.

12.3.1 Two-slit Interference

Consider a two-slit interference experiment where electrons having charge $q = e$ are injected from a point source at \mathbf{r}_a (see Fig. 12.1). A collector at point \mathbf{r}_b measures the probability density to detect an electron at that point. A very long impenetrable cylinder is placed near the gap between the slits in order to produce a magnetic field inside the cylinder in the direction normal to the plane of the figure. The field outside the cylinder, however, can be made arbitrarily small, and in what follows we assume that it vanishes.

The probability density P_b to detect the electron at time t by the collector located at point \mathbf{r}_b is given by

$$P_b = |K(\mathbf{r}_b, t; \mathbf{r}_a)|^2, \quad (12.44)$$

where the propagator (12.34) is given for this case by

$$K(\mathbf{r}_b, t; \mathbf{r}_a) = \int_{\mathbf{r}_a}^{\mathbf{r}_b} \mathcal{D}[\mathbf{r}(t)] \exp\left(\frac{iS_{0,\mathbf{r}(t)}}{\hbar}\right) \exp\left(\frac{ie}{\hbar c} \int_{\mathbf{r}(t)} \mathbf{dr} \cdot \mathbf{A}\right), \quad (12.45)$$

where the trajectories $\mathbf{r}(t)$ satisfy $\mathbf{r}(0) = \mathbf{r}_a$ and $\mathbf{r}(t) = \mathbf{r}_b$.

How P_b is modified when the magnetic field is turned on, and consequently the last factor in Eq. (12.45) starts to play a role? To answer this question it is convenient to divide the sum over all paths into two groups, one for all

paths going through the left slit, and another for all paths going through the right one. Here we disregard paths crossing a slit more than one time, as their contribution is expected to be small. In general, the difference Θ_{12} between the vector potential phase factor in Eq. (12.45) associated with two different paths $\mathbf{r}_1(t)$ and $\mathbf{r}_2(t)$ is given by

$$\begin{aligned}\Theta_{12} &= \frac{e}{\hbar c} \left(\int_{\mathbf{r}_1(t)} \mathbf{dr} \cdot \mathbf{A} - \int_{\mathbf{r}_2(t)} \mathbf{dr} \cdot \mathbf{A} \right) \\ &= \frac{e}{\hbar c} \oint \mathbf{dr} \cdot \mathbf{A},\end{aligned}\tag{12.46}$$

where the closed path integral is evaluated along the path $\mathbf{r}_1(t)$ in the forward direction from \mathbf{r}_a to \mathbf{r}_b , and then along the path $\mathbf{r}_2(t)$ in the backward direction from \mathbf{r}_b back to \mathbf{r}_a . This integral can be calculated using Stokes' theorem [see Eq. (12.2)]

$$\Theta_{12} = \frac{e}{\hbar c} \oint \mathbf{dr} \cdot \mathbf{A} = \frac{e}{\hbar c} \int \mathbf{ds} \cdot \mathbf{B} = 2\pi \frac{\phi}{\phi_0},\tag{12.47}$$

where ϕ is the magnetic flux threaded through the area enclosed by the closed path, and where

$$\phi_0 = \frac{hc}{e}\tag{12.48}$$

is the so called *flux quantum*. While Θ_{12} vanishes for pairs of paths going through the same slit, it has the same value $\Theta_{12} = 2\pi\phi/\phi_0$ ($\Theta_{12} = -2\pi\phi/\phi_0$) for all the pairs where $\mathbf{r}_1(t)$ goes through the left (right) path and where $\mathbf{r}_2(t)$ goes through the right (left) one. Thus, we come to the somewhat surprising conclusion that the probability density P_b is expected to be dependent on the magnetic field. The expected dependence is periodic in the magnetic flux ϕ with flux quantum ϕ_0 period. Such dependence cannot be classically understood, since in this example the electrons can never enter the region in which the magnetic field \mathbf{B} is finite, and thus the Lorentz force vanishes in the entire region accessible for the electrons outside the impenetrable coil.

12.3.2 Gauge Invariance

Consider the following gauge transformation

$$\mathbf{A} \rightarrow \tilde{\mathbf{A}} = \mathbf{A} + \nabla\chi,\tag{12.49}$$

$$\varphi \rightarrow \tilde{\varphi} = \varphi,\tag{12.50}$$

where $\chi = \chi(\mathbf{r})$ is an arbitrary smooth and continuous function of \mathbf{r} , which is assumed to be time independent. As can be seen from Eqs. (12.1) and

(12.2), this transformation leaves \mathbf{E} and \mathbf{B} unchanged, since $\nabla \times (\nabla \chi) = 0$. In chapter 1 we have seen that such a gauge transformation [see Eqs. (1.44) and 1.45)] modifies the Lagrangian [see Eq. (1.43)]

$$\mathcal{L} \rightarrow \tilde{\mathcal{L}} = \mathcal{L} + \frac{q}{c} \nabla \chi \cdot \dot{\mathbf{r}}, \quad (12.51)$$

and also the action [see Eq. (12.37) and compare with Eq. (1.73)]

$$\begin{aligned} S \rightarrow \tilde{S} &= S + \int_0^t dt \frac{q}{c} \nabla \chi \cdot \dot{\mathbf{r}} \\ &= S + \frac{q}{c} \int_{\mathbf{r}_a}^{\mathbf{r}_b} d\mathbf{r} \cdot \nabla \chi \\ &= S + \frac{q}{c} [\chi(\mathbf{r}_b) - \chi(\mathbf{r}_a)], \end{aligned} \quad (12.52)$$

however, the classical motion is unaffected.

In quantum mechanics, the propagator is expressed as a path integral [see Eq. (12.34)], where each path $\mathbf{r}(t)$ contributes a phase factor given by $\exp(iS_{\mathbf{r}(t)}/\hbar)$. As can be seen from Eq. (12.52), this phase factor is generally not singly determined, since it depends on the chosen gauge. This result, however, should not be considered as paradoxical, since only phase difference between different paths has any physical meaning. Indeed, as we have seen above [see Eq. (12.47)], phase difference Θ_{12} , which determines the relative phase between two different paths, is evaluated along a closed path, which is singly determined, and therefore gauge invariant.

Exercise 12.3.1. Given that the wavefunction $\psi(\mathbf{r}', t')$ solves the Schrödinger equation with vector \mathbf{A} and scalar φ potentials, show that the wavefunction $\tilde{\psi}(\mathbf{r}', t')$, which is given by

$$\tilde{\psi}(\mathbf{r}', t') = \exp\left(\frac{iq\chi(\mathbf{r}')}{\hbar c}\right) \psi(\mathbf{r}', t'), \quad (12.53)$$

solves the Schrödinger equation with vector $\tilde{\mathbf{A}} = \mathbf{A} + \nabla \chi$ and scalar $\tilde{\varphi} = \varphi$ potentials.

Solution 12.3.1. Using Eq. (3.76) one finds that

$$\begin{aligned} &\exp\left(-\frac{iq\chi}{\hbar c}\right) \mathbf{p} \exp\left(\frac{iq\chi}{\hbar c}\right) \\ &= \exp\left(-\frac{iq\chi}{\hbar c}\right) \left[\mathbf{p}, \exp\left(\frac{iq\chi}{\hbar c}\right) \right] + \mathbf{p} \\ &= \mathbf{p} + \frac{q\nabla \chi}{c}. \end{aligned} \quad (12.54)$$

This result implies that

$$\exp\left(-\frac{iq\chi}{\hbar c}\right) \left(\mathbf{p} - \frac{q}{c}\mathbf{A} - \frac{q}{c}\nabla\chi\right) \exp\left(\frac{iq\chi}{\hbar c}\right) = \left(\mathbf{p} - \frac{q}{c}\mathbf{A}\right), \quad (12.55)$$

and therefore the following holds

$$\exp\left(-\frac{iq\chi}{\hbar c}\right) \tilde{\mathcal{H}} \exp\left(\frac{iq\chi}{\hbar c}\right) = \mathcal{H}, \quad (12.56)$$

where [see Eq. (1.62)]

$$\mathcal{H} = \frac{\left(\mathbf{p} - \frac{q}{c}\mathbf{A}\right)^2}{2m} + q\varphi \quad (12.57)$$

is the Hamiltonian corresponding to the vector potential \mathbf{A} , whereas

$$\tilde{\mathcal{H}} = \frac{\left(\mathbf{p} - \frac{q}{c}\mathbf{A} - \frac{q}{c}\nabla\chi\right)^2}{2m} + q\varphi, \quad (12.58)$$

is the Hamiltonian corresponding to the vector potential $\tilde{\mathbf{A}}$. Thus, one finds that the state vector

$$|\tilde{\psi}\rangle = \exp\left(\frac{iq\chi}{\hbar c}\right) |\psi\rangle \quad (12.59)$$

solves the Schrödinger equation with $\tilde{\mathcal{H}}$, provided that the state vector $|\psi\rangle$ solves the Schrödinger equation with \mathcal{H} , and therefore [compare with Eq. (1.73)]

$$\tilde{\psi}(\mathbf{r}', t') = \exp\left(\frac{iq\chi(\mathbf{r}')}{\hbar c}\right) \psi(\mathbf{r}', t'). \quad (12.60)$$

12.4 One-Dimensional Path Integrals

Consider a point particle having mass m moving in one dimension along the x axis under the influence of the potential $V(x)$. The path integral (12.34) for this case becomes

$$K(x_b, t; x_a) = \lim_{N \rightarrow \infty} \left(\frac{Nm}{2\pi i\hbar}\right)^{N/2} \prod_{n=1}^{N-1} \int dx_n \exp\left(\frac{i}{\hbar} \frac{t}{N} \sum_{m=0}^{N-1} \mathcal{L}\left(x_m, \frac{x_{m+1} - x_m}{\frac{t}{N}}\right)\right). \quad (12.61)$$

where the Lagrangian is

$$\mathcal{L}(x, \dot{x}) = \frac{1}{2}m\dot{x}^2 - V(x). \quad (12.62)$$

The solution of the Euler Lagrange equation, which is given by Eq. (1.8)

$$\frac{d}{dt} \frac{\partial \mathcal{L}}{\partial \dot{x}} = \frac{\partial \mathcal{L}}{\partial x}, \quad (12.63)$$

yields the classical equation of motion of the system

$$m\ddot{x} = -\frac{dV}{dx}. \quad (12.64)$$

12.4.1 One-Dimensional Free Particle

For this case $V(x) = 0$.

Exercise 12.4.1. Show that

$$K(x_b, t; x_a) = \sqrt{\frac{m}{2\pi i \hbar t}} \exp\left[\frac{im}{2\hbar t} (x_b - x_a)^2\right]. \quad (12.65)$$

Solution 12.4.1. The path integral (12.61) for this case becomes

$$K(x_b, t; x_a) = \lim_{N \rightarrow \infty} \left(-\frac{imN}{2\pi \hbar t}\right)^{N/2} \prod_{n=1}^{N-1} \int dx_n \exp\left[\frac{imN}{2\hbar t} \sum_{m=0}^{N-1} (x_{m+1} - x_m)^2\right], \quad (12.66)$$

or

$$K(x_b, t; x_a) = \lim_{N \rightarrow \infty} \left(\frac{\alpha}{\pi}\right)^{N/2} \prod_{n=1}^{N-1} \int dx_n \exp\left[-\alpha \sum_{m=0}^{N-1} (x_{m+1} - x_m)^2\right], \quad (12.67)$$

where

$$\alpha = -\frac{imN}{2\hbar t}. \quad (12.68)$$

The first integral $\int dx_1$ can be calculated using the identity

$$\int_{-\infty}^{\infty} dx_1 \exp\left[-\alpha (x_2 - x_1)^2 - \alpha (x_1 - x_0)^2\right] = \sqrt{\frac{\pi}{2\alpha}} \exp\left[-\frac{\alpha}{2} (x_2 - x_0)^2\right], \quad (12.69)$$

The second integral $\int dx_2$ can be calculated using the identity

$$\int_{-\infty}^{\infty} dx_2 \exp\left[-\alpha (x_3 - x_2)^2 - \frac{\alpha}{2} (x_2 - x_0)^2\right] = \sqrt{\frac{2\pi}{3\alpha}} \exp\left[-\frac{\alpha}{3} (x_3 - x_0)^2\right].$$

$$(12.70)$$

Similarly, the n th integral $\int dx_n$ yields

$$\sqrt{\frac{n\pi}{(n+1)\alpha}} \exp\left[-\frac{\alpha}{n+1}(x_{n+1}-x_0)^2\right]. \quad (12.71)$$

Therefore, the propagator is given by

$$K(x_b, t; x_a) = \lim_{N \rightarrow \infty} \left(\frac{\alpha}{\pi}\right)^{N/2} \sqrt{\frac{\pi}{2\alpha} \frac{2\pi}{3\alpha} \times \cdots \times \frac{(N-1)\pi}{N\alpha}} \exp\left[-\frac{\alpha}{N}(x_b - x_a)^2\right], \quad (12.72)$$

or

$$K(x_b, t; x_a) = \sqrt{\frac{m}{2\pi i \hbar t}} \exp\left[\frac{im}{2\hbar t}(x_b - x_a)^2\right]. \quad (12.73)$$

As can be seen from the classical equation of motion (12.64), a free particle moves at a constant velocity. Thus, the classical path satisfying $x(0) = x_a$ and $x(t) = x_b$ is given by

$$x_c(t') = x_a + \frac{(x_b - x_a)t'}{t}. \quad (12.74)$$

The corresponding classical action S_c is

$$S_c = \int_{x_c(t')} dt' \mathcal{L}(x, \dot{x}) = \frac{m(x_b - x_a)^2}{2t}. \quad (12.75)$$

Note that the following holds

$$\frac{d^2 S_c}{dx_a dx_b} = -\frac{m}{t}. \quad (12.76)$$

Thus the propagator can be expressed in terms of the classical action S_c as

$$K(x_b, t; x_a) = \sqrt{\frac{i}{2\pi\hbar} \frac{d^2 S_c}{dx_a dx_b}} \exp\left(\frac{i}{\hbar} S_c\right). \quad (12.77)$$

As we will see below, a similar expression for the propagator is obtained also for other cases.

12.4.2 Expansion Around the Classical Path

Motivated by the previous example of a free particle, we attempt below to relate the propagator for the more general case, where $V(x)$ is allowed to be

x dependent, with the classical path $x_c(t')$ and the corresponding classical action S_c . Consider a general path $x(t')$ satisfying the boundary conditions $x(0) = x_a$ and $x(t) = x_b$. It is convenient to express the path as

$$x(t') = x_c(t') + \delta(t') , \quad (12.78)$$

where the deviation $\delta(t')$ from the classical path $x_c(t')$ vanishes at the end points $\delta(0) = \delta(t) = 0$. The action associated with the path $x(t')$ can be expressed as

$$S = \int_{x(t')} dt' \mathcal{L}(x, \dot{x}) , \quad (12.79)$$

where the Lagrangian is given by Eq. (12.62).

Expanding S in orders of δ yields

$$S = S_c + S_1 + S_2 + \dots , \quad (12.80)$$

where

$$S_c = \int dt' \mathcal{L}(x, \dot{x}) , \quad (12.81)$$

$$S_1 = \int dt' \left(\left. \frac{\partial \mathcal{L}}{\partial x} \right|_{x=x_c} \delta + \left. \frac{\partial \mathcal{L}}{\partial \dot{x}} \right|_{x=x_c} \dot{\delta} \right) , \quad (12.82)$$

$$S_2 = \int dt' \left(\left. \frac{\partial^2 \mathcal{L}}{\partial x^2} \right|_{x=x_c} \delta^2 + 2 \left. \frac{\partial^2 \mathcal{L}}{\partial x \partial \dot{x}} \right|_{x=x_c} \delta \dot{\delta} + \left. \frac{\partial^2 \mathcal{L}}{\partial \dot{x}^2} \right|_{x=x_c} \dot{\delta}^2 \right) . \quad (12.83)$$

In the general case, higher orders in such an expansion may play an important role, however, as will be discussed below, in the classical limit the dominant contribution to the path integral comes from the lowest order terms.

Claim. $S_1 = 0$.

Proof. Integrating by parts the term proportional to $\dot{\delta}$ in the expression for S_1 yields

$$S_1 = \left(\left. \frac{\partial \mathcal{L}}{\partial \dot{x}} \right|_{x=x_c} \delta \right) \Big|_0^t + \int dt' \left(\left. \frac{\partial \mathcal{L}}{\partial x} \right|_{x=x_c} - \frac{d}{dt} \left. \frac{\partial \mathcal{L}}{\partial \dot{x}} \right|_{x=x_c} \right) \delta . \quad (12.84)$$

The first term in Eq. (12.84) vanishes due to the boundary conditions $\delta(0) = \delta(t) = 0$, whereas the second one vanishes because $x_c(t')$ satisfies the Euler Lagrange equation (12.63), thus $S_1 = 0$. The fact that S_1 vanishes is a direct consequence of the principle of least action of classical mechanics that was discussed in chapter 1.

Employing the coordinate transformation (12.78) and the expansion of S around the classical path allows rewriting the path integral (12.61) as

$$K(x_b, t; x_a) = P_c(x_b, t; x_a) \mathcal{K}(t) , \quad (12.85)$$

where

$$P_c(x_b, t; x_a) = \exp\left(\frac{iS_c}{\hbar}\right) , \quad (12.86)$$

$$\mathcal{K}(t) = \int \mathcal{D}[\delta(t')] \exp\left(\frac{i}{\hbar} (S_2 + O(\delta^3))\right) , \quad (12.87)$$

and where

$$\int \mathcal{D}[\delta(t')] = \lim_{N \rightarrow \infty} \left(\frac{Nm}{2\pi i \hbar}\right)^{N/2} \prod_{n=1}^{N-1} \int d\delta_n . \quad (12.88)$$

The term $\mathcal{K}(t)$ is evaluated by integrating over all paths $\delta(t')$ satisfying the boundary conditions $\delta(0) = \delta(t) = 0$.

Exercise 12.4.2. Show that

$$\frac{\int dx' P_c(x_b, t_2; x') P_c(x', t_1; x_a)}{P_c(x_b, t_1 + t_2; x_a)} = \frac{\mathcal{K}(t_1 + t_2)}{\mathcal{K}(t_1) \mathcal{K}(t_2)} . \quad (12.89)$$

Solution 12.4.2. As can be seen from the definition of the propagator (12.7), the following holds

$$\begin{aligned} \int dx' K(x_b, t_2; x') K(x', t_1; x_a) &= \int dx' \langle x_b | u(t_2) | x' \rangle \langle x' | u(t_1) | x_a \rangle \\ &= \langle x_b | u(t_1 + t_2) | x_a \rangle \\ &= K(x_b, t_1 + t_2; x_a) . \end{aligned} \quad (12.90)$$

Requiring that this property is satisfied by the propagator $K(x_b, t; x_a)$ that is given by Eq. (12.85) leads to

$$\frac{\int dx' P_c(x_b, t_2; x') P_c(x', t_1; x_a)}{P_c(x_b, t_1 + t_2; x_a)} = \frac{\mathcal{K}(t_1 + t_2)}{\mathcal{K}(t_1) \mathcal{K}(t_2)} . \quad (12.91)$$

12.4.3 One-Dimensional Harmonic Oscillator

For this case the Lagrangian is taken to be given by

$$\mathcal{L}(x, \dot{x}) = \frac{m\dot{x}^2}{2} + \frac{m\omega_1 x \dot{x}}{2} - \frac{m\omega^2 x^2}{2} , \quad (12.92)$$

where m , ω and ω_1 are assumed to be real constants. As we will see below, the term $(m\omega_1/2)x\dot{x}$ doesn't affect the dynamics, however, it is taken into account in order to allow studying the more general case where the Lagrangian contains all possible types of quadratic (in x and \dot{x}) terms (though, for simplicity, all coefficients in the Lagrangian are assumed to be time independent). Consider a general path $x(t')$ satisfying the boundary conditions $x(0) = x_a$ and $x(t) = x_b$. Using the notation

$$x(t') = x_c(t') + \delta(t') ,$$

the Lagrangian becomes

$$\mathcal{L}(x, \dot{x}) = \frac{m}{2} \left[(\dot{x}_c + \dot{\delta})^2 + \omega_1 (x_c + \delta) (\dot{x}_c + \dot{\delta}) - \omega^2 (x_c + \delta)^2 \right] , \quad (12.93)$$

thus the action associated with the path $x(t')$ can be expressed as

$$S = \int_{x(t')} dt' \mathcal{L}(x, \dot{x}) = S_c + S_1 + S_2 , \quad (12.94)$$

where

$$S_c = \frac{m}{2} \int_0^t dt' (\dot{x}_c^2 + \omega_1 x_c \dot{x}_c - \omega^2 x_c^2) , \quad (12.95)$$

$$S_1 = m \int_0^t dt' \left[\dot{x}_c \dot{\delta} + \frac{\omega_1}{2} (x_c \dot{\delta} + \delta \dot{x}_c) - \omega^2 x_c \delta \right] , \quad (12.96)$$

$$S_2 = \frac{m}{2} \int_0^t dt' (\dot{\delta}^2 + \omega_1 \delta \dot{\delta} - \omega^2 \delta^2) . \quad (12.97)$$

As we have seen above, the principle of least action implies that $S_1 = 0$. Note that in this case the expansion to second order in δ is exact and all higher order terms vanish. Thus, the exact solution of this problem will also provide an approximate solution for systems whose Lagrangian can be approximated by a quadratic one.

Exercise 12.4.3. Find the classical action S_c of a classical path satisfying $x(0) = x_a$ and $x(t) = x_b$.

Solution 12.4.3. The Euler Lagrange equation (12.63)

$$\frac{d}{dt} \frac{\partial \mathcal{L}}{\partial \dot{x}} = \frac{\partial \mathcal{L}}{\partial x} , \quad (12.98)$$

for this case yields

$$\ddot{x} = -\omega^2 x, \quad (12.99)$$

thus, indeed the term $(m\omega_1/2) x\dot{x}$ doesn't affect the dynamics. Requiring also boundary conditions $x(0) = x_a$ and $x(t) = x_b$ leads to

$$x_c(t') = \frac{x_b \sin(\omega t') - x_a \sin(\omega(t' - t))}{\sin(\omega t)}. \quad (12.100)$$

To evaluate the corresponding action we calculate the following integrals

$$\begin{aligned} & \int_0^t dt' (\dot{x}_c^2 - \omega^2 x_c^2) = \\ & \frac{\omega^2}{\sin^2(\omega t)} \int_0^t dt' \left[(x_b \cos(\omega t') - x_a \cos(\omega(t' - t)))^2 \right. \\ & \quad \left. - (x_b \sin(\omega t') - x_a \sin(\omega(t' - t)))^2 \right] \\ & = \omega \left[(x_a^2 + x_b^2) \cot(\omega t) - \frac{2x_a x_b}{\sin(\omega t)} \right] \\ & = \omega \left[(x_a - x_b)^2 \cot(\omega t) - 2x_a x_b \tan\left(\frac{\omega t}{2}\right) \right], \end{aligned} \quad (12.101)$$

and

$$\begin{aligned} & \int_0^t dt' x_c \dot{x}_c \\ & = \frac{\omega \int_0^t dt' (x_b \sin(\omega t') - x_a \sin(\omega(t' - t))) (x_b \cos(\omega t') - x_a \cos(\omega(t' - t)))}{\sin^2(\omega t)} \\ & = \frac{x_b^2 - x_a^2}{2}, \end{aligned} \quad (12.102)$$

thus, the action is given by

$$\begin{aligned} S_c & = \int_{x_c(t')} dt' \mathcal{L}(x, \dot{x}) \\ & = \frac{m\omega}{2} \left[(x_a - x_b)^2 \cot(\omega t) - 2x_a x_b \tan\left(\frac{\omega t}{2}\right) \right] + \frac{m\omega_1 (x_b^2 - x_a^2)}{4}. \end{aligned} \quad (12.103)$$

To evaluate the propagator according to Eq. (12.85) the factor $\mathcal{K}(t)$ has to be determined. This can be done by employing relation (12.89) for the case where $x_a = x_b = 0$

$$\frac{\int dx' P_c(0, t_2; x') P_c(x', t_1; 0)}{P_c(0, t_1 + t_2; 0)} = \frac{\mathcal{K}(t_1 + t_2)}{\mathcal{K}(t_1) \mathcal{K}(t_2)}. \quad (12.104)$$

Exercise 12.4.4. Show that

$$\mathcal{K}(t) = \sqrt{\frac{m\omega}{2\pi i \hbar \sin(\omega t)}}. \quad (12.105)$$

Solution 12.4.4. By using Eqs. (12.103) and (12.104) one finds that

$$\int dx' \exp\left[i\frac{m\omega}{2\hbar}(\cot(\omega t_2) + \cot(\omega t_1))x'^2\right] = \frac{\mathcal{K}(t_1 + t_2)}{\mathcal{K}(t_1) \mathcal{K}(t_2)}, \quad (12.106)$$

thus, using the general integral identity

$$\int_{-\infty}^{\infty} dx' \exp(i\alpha x'^2) = \sqrt{\frac{i\pi}{\alpha}}, \quad (12.107)$$

where α is real, one finds that

$$\sqrt{\frac{2\pi i \hbar}{m\omega(\cot(\omega t_2) + \cot(\omega t_1))}} = \frac{\mathcal{K}(t_1 + t_2)}{\mathcal{K}(t_1) \mathcal{K}(t_2)}. \quad (12.108)$$

Alternatively, using the identity

$$\frac{1}{\cot(\omega t_2) + \cot(\omega t_1)} = \frac{\sin(\omega t_1) \sin(\omega t_2)}{\sin(\omega(t_1 + t_2))}, \quad (12.109)$$

this can be rewritten as

$$\sqrt{\frac{2\pi i \hbar \sin(\omega t_1) \sin(\omega t_2)}{m\omega \sin(\omega(t_1 + t_2))}} = \frac{\mathcal{K}(t_1 + t_2)}{\mathcal{K}(t_1) \mathcal{K}(t_2)}. \quad (12.110)$$

Consider a solution having the form

$$\mathcal{K}(t) = e^{f(t)} \sqrt{\frac{m\omega}{2\pi i \hbar \sin(\omega t)}}, \quad (12.111)$$

where $f(t)$ is an arbitrary function of time. Substituting this into Eq. (12.110) yields

$$f(t_1) + f(t_2) = f(t_1 + t_2), \quad (12.112)$$

thus $f(t) = At$, where A is a constant. Combining all these results the propagator (12.85) for the present case becomes

$$\begin{aligned}
 K(x_b, t; x_a) &= e^{At} \sqrt{\frac{m\omega}{2\pi i \hbar \sin(\omega t)}} \\
 &\times \exp\left(\frac{i}{\hbar} \frac{m\omega}{2} \left[(x_a - x_b)^2 \cot(\omega t) - 2x_a x_b \tan\left(\frac{\omega t}{2}\right) \right] + \frac{m\omega_1 (x_b^2 - x_a^2)}{4}\right).
 \end{aligned} \tag{12.113}$$

In addition we require that in the limit $\omega, \omega_1 \rightarrow 0$ the above result will approach the result given by Eq. (12.65) for the propagator of a free particle. This requirement yields $A = 0$. Note that

$$(x_a - x_b)^2 \cot(\omega t) - 2x_a x_b \tan\left(\frac{\omega t}{2}\right) = (x_a^2 + x_b^2) \cot(\omega t) - \frac{2x_a x_b}{\sin(\omega t)}. \tag{12.114}$$

For the case $\omega_1 = 0$ the propagator $K(x_b, t; x_a)$ becomes

$$\begin{aligned}
 K(x_b, t; x_a) &= \sqrt{\frac{m\omega}{2\pi i \hbar \sin(\omega t)}} \\
 &\times \exp\left(\frac{i m \omega}{2 \hbar \sin(\omega t)} [(x_a^2 + x_b^2) \cos(\omega t) - 2x_a x_b]\right).
 \end{aligned} \tag{12.115}$$

As can be seen from Eq. (12.103), the following holds

$$\frac{d^2 S_c}{dx_a dx_b} = -\frac{m\omega}{\sin(\omega t)}, \tag{12.116}$$

thus, similar to the case of a free particle [see Eq. (12.77)], also for the present case of a harmonic oscillator, the propagator can be expressed in terms of the classical action S_c as

$$K(x_b, t; x_a) = \sqrt{\frac{i}{2\pi \hbar} \frac{d^2 S_c}{dx_a dx_b}} \exp\left(\frac{i}{\hbar} S_c\right). \tag{12.117}$$

12.5 Semiclassical Limit

In the semiclassical limit the Planck's constant \hbar is considered to be small. In this limit the dominant contribution to the path integral comes only from paths near the classical one, which has the least action. This implies that in the expansion of S around the classical path (12.80) terms of order $O(\delta^3)$ can be approximately neglected. Thus, as can be seen from Eq. (12.87), in this limit [see also Eq. (12.85)] the propagator $K(x_b, t; x_a)$ is evaluated by path integration over the quadratic terms S_2 only of the action [see Eq.

(12.83)]. In the previous section we have exactly calculated the propagator associated with the quadratic Lagrangian of a harmonic oscillator. The result was expressed in Eq. (12.117) in terms of the classical action S_c . As can be seen from Eq. (12.77), the same expression is applicable also for the case of a free particle. It can be shown that the same form is also applicable for expressing the propagator $K(x_b, t; x_a)$ in the semiclassical limit for the general case

$$K(x_b, t; x_a) = \sqrt{\frac{i}{2\pi\hbar} \frac{d^2 S_c}{dx_a dx_b}} \exp\left(\frac{i}{\hbar} S_c\right). \quad (12.118)$$

The proof of the above result, which requires generalization of the derivation that led to Eq. (12.117) for the case of a general quadratic Lagrangian, will not be given here. Another important result, which also is given here without a proof, generalizes Eq. (12.118) for the case of motion in n spacial dimensions

$$K(\mathbf{r}_b, t; \mathbf{r}_a) = \sqrt{\det\left(\frac{i}{2\pi\hbar} \frac{d^2 S_c}{d\mathbf{r}_a d\mathbf{r}_b}\right)} \exp\left(\frac{i}{\hbar} S_c\right). \quad (12.119)$$

12.6 Problems

1. Consider a particle having mass m confined by a one-dimensional potential well given by

$$V(x) = \begin{cases} 0 & 0 < x < L \\ \infty & \text{else} \end{cases}, \quad (12.120)$$

where L is a positive constant. Calculate the propagator $K(x'_b, t; x'_a)$ of the system.

2. Calculate the propagator of a particle having mass m that is confined to move along a (one-dimensional) ring of radius a (but is otherwise free).
3. Show that

$$e^{\epsilon(A+B)} = e^{\epsilon A} e^{\epsilon B} + O(\epsilon^2), \quad (12.121)$$

where A and B are operators.

4. Show that

$$e^{\epsilon(A+B)} = e^{\epsilon B/2} e^{\epsilon A} e^{\epsilon B/2} + O(\epsilon^3), \quad (12.122)$$

where A and B are operators.

5. Show that

$$\exp\left(-\frac{i\epsilon\mathbf{V}^2}{2m\hbar}\right) = \frac{1}{(2\pi i)^{3/2}} \int d^3\mathbf{r}' \exp\left(\frac{i\mathbf{r}'^2}{2} - i\sqrt{\frac{\epsilon}{m\hbar}} \mathbf{V} \cdot \mathbf{r}'\right), \quad (12.123)$$

where \mathbf{V} is a vector operator.

6. Show that the energy (12.38) is indeed a constant of the motion.
7. The time-independent Hamiltonian \mathcal{H} of a point particle moving in one dimension along the x axis is assumed to be a function of the momentum operator p only (i.e. \mathcal{H} is independent on the position operator x). Find a general expression for the propagator $K(x_b, t; x_a)$ (12.7) in terms of the Fourier transform of $\exp(-i\hbar^{-1}\mathcal{H}(p')t)$ (no integration over paths is needed for deriving that expression). Show that the general expression is consistent with the propagator of a free particle given by Eq. (12.65).
8. Let \mathcal{H} be a time-independent Hamiltonian of a point particle moving in one dimension along the x axis. Find a general expression for the propagator $K(x_b, t; x_a)$ (12.7) in terms of the set of eigenvectors $\{|a_n\rangle\}$ and the corresponding energy eigenvalues $\{E_n\}$ of \mathcal{H} , which satisfy $\mathcal{H}|a_n\rangle = E_n|a_n\rangle$ (no integration over paths is needed for deriving that expression). Show that the general expression is consistent with the propagator of a harmonic oscillator given by Eq. (12.115).
9. Consider a quantum system having time independent Hamiltonian \mathcal{H} and a discrete energy spectrum. Express its partition function Z in terms of the systems's propagator $K(x_b, t; x_a)$.
10. Consider a one-dimensional harmonic oscillator having mass m and resonance angular frequency ω in thermal equilibrium at temperature T . Calculate the matrix elements $\langle x'' | \rho | x' \rangle$ of the density operator in the basis of eigenvectors $|x'\rangle$ of the position operator x .
11. Consider a free particle in one dimension having mass m . Calculate the position wavefunction $\psi(x', t)$ at time t given that the position wavefunction $\psi(x', 0)$ at time $t = 0$ is given by

$$\psi(x', 0) = \frac{1}{\pi^{1/4}x_0^{1/2}} \exp\left(-\frac{1}{2}\left(\frac{x'}{x_0}\right)^2\right). \quad (12.124)$$

where x_0 is a constant.

12. A particle having mass m is in the ground state of the potential well $V_0(x) = (1/2)m\omega^2x^2$ for times $t < 0$. At time $t = 0$ the potential suddenly changes and becomes $V_1(x) = mgx$.
 - a) Calculate the propagator $K(x_b, t; x_a)$ from point x_a to point x_b in the semiclassical limit for the case where the potential is $V_1(x)$ (i.e. for the Hamiltonian after the change at $t = 0$).
 - b) Use the result of the previous section to calculate the variance $\langle (\Delta x)^2(t) \rangle = \langle x^2(t) \rangle - \langle x(t) \rangle^2$ of the position operator x at time t .
13. Consider a particle having mass m in the one-dimensional potential well $V_0(x) = (1/2)m\omega^2x^2$, where the angular frequency ω is a positive constant. Employ path integration to calculate the position wavefunction $\psi(x', t)$ at time t , for the case where the position wavefunction $\psi(x', t = 0)$ at time $t = 0$ is given by

$$\psi(x', t=0) = \frac{1}{\pi^{1/4} x_i^{1/2}} \exp\left(-\frac{1}{2} \left(\frac{x'}{x_i}\right)^2\right), \quad (12.125)$$

where x_i is a positive constant.

12.7 Solutions

1. The propagator is defined by $K(x'_b, t; x'_a) = \langle x'_b | u(t) | x'_a \rangle$, where $u(t)$ is the time evolution operator [see Eq. (12.7)]. Since the Hamiltonian \mathcal{H} of the system is time independent the operator $u(t)$ can be expressed in terms of the eigenvectors of \mathcal{H} , which are denoted by $|a_n\rangle$, and the corresponding energy eigenvalues E_n . With the help of Eq. (4.13) one finds that

$$K(x'_b, t; x'_a) = \sum_{n=1}^{\infty} \exp\left(-\frac{iE_n t}{\hbar}\right) \langle x'_b | a_n \rangle \langle a_n | x'_a \rangle. \quad (12.126)$$

With the help of Eqs. (4.254) and (4.255)] this becomes

$$K(x'_b, t; x'_a) = \frac{2}{L} \sum_{n=1}^{\infty} \exp\left(-\frac{i\pi^2 \hbar^2 n^2 t}{2\hbar m L^2}\right) \sin \frac{n\pi x'_a}{L} \sin \frac{n\pi x'_b}{L}. \quad (12.127)$$

2. With the help of Eqs. (6.603), (6.604) and (12.126) one finds that the propagator $K(\phi'_b, t; \phi'_a)$ from angle ϕ'_a to angle ϕ'_b is given by

$$K(\phi'_b, t; \phi'_a) = \frac{1}{2\pi a} \sum_{n=-\infty}^{\infty} g(n), \quad (12.128)$$

where the function $g(n)$ is given by

$$g(n) = e^{-in^2 \omega t} e^{in(\phi'_b - \phi'_a)}, \quad (12.129)$$

and where $\omega = \hbar/2ma^2$. Alternatively, $K(\phi'_b, t; \phi'_a)$ can be calculated using Eq. (12.65) for the propagator of a free particle moving along a one dimension line by summation over all final points shifted by an integer times the circumference of the circle $2\pi a$

$$\begin{aligned} K(\phi'_b, t; \phi'_a) &= \sqrt{\frac{m}{2\pi i \hbar t}} \sum_{n=-\infty}^{\infty} \exp\left[\frac{ima^2}{2\hbar t} (2\pi n + \phi'_b - \phi'_a)^2\right] \\ &= \frac{1}{2\pi a} \sqrt{\frac{\pi}{i\omega t}} \sum_{n=-\infty}^{\infty} \exp\left[\frac{i\pi^2}{\omega t} \left(n + \frac{\phi'_b - \phi'_a}{2\pi}\right)^2\right]. \end{aligned} \quad (12.130)$$

As is shown below, the so-called Poisson summation formula can be used to show that the above results (12.128) and (12.130) are identical. The function $G(x)$, which is defined by [see Eq. (12.128)]

$$G(x) = \sum_{n=-\infty}^{\infty} g(x+n) , \quad (12.131)$$

is periodic with period unity, and thus it can be Fourier expanded as

$$\begin{aligned} G(x) &= \sum_{n'=-\infty}^{\infty} e^{2\pi i n' x} \int_0^1 dx' G(x') e^{-2\pi i n' x'} \\ &= \sum_{n'=-\infty}^{\infty} e^{2\pi i n' x} \sum_{n=-\infty}^{\infty} \int_0^1 dx' g(x'+n) e^{-2\pi i n' x'} \\ &= \sum_{n'=-\infty}^{\infty} e^{2\pi i n' x} \int_{-\infty}^{\infty} dx'' g(x'') e^{-2\pi i n' x''} . \end{aligned} \quad (12.132)$$

For the case $x = 0$ one obtains

$$\sum_{n=-\infty}^{\infty} g(n) = \sum_{n'=-\infty}^{\infty} \int_{-\infty}^{\infty} dx'' g(x'') e^{-2\pi i n' x''} . \quad (12.133)$$

The above result together with Eq. (5.149) lead to [see Eq. (12.129)]

$$\sum_{n=-\infty}^{\infty} g(n) = \sqrt{\frac{\pi}{i\omega t}} \sum_{n=-\infty}^{\infty} \exp \left[\frac{i\pi^2}{\omega t} \left(n + \frac{\phi'_b - \phi'_a}{2\pi} \right)^2 \right] , \quad (12.134)$$

in agreement with Eq. (12.130).

3. Consider the operator

$$C(\epsilon) = e^{-\epsilon A} e^{\epsilon(A+B)} e^{-\epsilon B} . \quad (12.135)$$

Clearly, $C(0) = 1$. Moreover, with the help of Eq. (2.179) one finds that

$$\frac{dC}{d\epsilon} = -e^{-\epsilon A} A e^{\epsilon(A+B)} e^{-\epsilon B} + e^{-\epsilon A} e^{\epsilon(A+B)} (A+B) e^{-\epsilon B} - e^{-\epsilon A} e^{\epsilon(A+B)} e^{-\epsilon B} B , \quad (12.136)$$

thus

$$\left. \frac{dC}{d\epsilon} \right|_{\epsilon=0} = -A + (A+B) - B = 0 , \quad (12.137)$$

namely

$$C(\epsilon) = 1 + O(\epsilon^2) ,$$

and therefor

$$e^{\epsilon(A+B)} = e^{\epsilon A} e^{\epsilon B} + O(\epsilon^2) . \quad (12.138)$$

4. Consider the operator

$$C(\epsilon) = e^{-\epsilon B/2} e^{\epsilon(A+B)} e^{-\epsilon B/2} e^{-\epsilon A} . \quad (12.139)$$

As in the previous exercise, it is straightforward (though, somewhat tedious) to show that

$$C(0) = 1 , \quad (12.140)$$

$$\left. \frac{dC}{d\epsilon} \right|_{\epsilon=0} = 0 , \quad (12.141)$$

$$\left. \frac{d^2 C}{d\epsilon^2} \right|_{\epsilon=0} = 0 , \quad (12.142)$$

thus

$$C(\epsilon) = 1 + O(\epsilon^3) , \quad (12.143)$$

and therefor

$$e^{\epsilon(A+B)} = e^{\epsilon B/2} e^{\epsilon A} e^{\epsilon B/2} + O(\epsilon^3) . \quad (12.144)$$

5. The proof is trivial using the identity

$$\int_{-\infty}^{\infty} e^{-\alpha x'^2 + \beta x'} dx' = \sqrt{\frac{\pi}{\alpha}} e^{\beta^2/4\alpha} . \quad (12.145)$$

6. By taking the time derivative of E one has

$$\frac{dE}{dt} = m\dot{\mathbf{r}} \cdot \ddot{\mathbf{r}} + q\nabla\varphi \cdot \dot{\mathbf{r}} = \dot{\mathbf{r}} \cdot (m\ddot{\mathbf{r}} - q\mathbf{E}) . \quad (12.146)$$

However, according to the equation of motion (1.60) the term in the brackets vanishes, and therefor $dE/dt = 0$.

7. The time evolution operator for the case where the Hamiltonian \mathcal{H} is time independent is given by $u(t) = \exp(-i\hbar^{-1}\mathcal{H}t)$ [see Eq. (4.9)], and thus the propagator can be expressed as [see Eq. (12.7)]

$$K(x_b, t; x_a) = \langle x_b | \exp\left(-i\frac{\mathcal{H}t}{\hbar}\right) | x_a \rangle . \quad (12.147)$$

With the help of the closure relation (3.45), which reads $\int dp' |p'\rangle \langle p'| = 1$, and Eq. (3.52), which reads $\langle x' | p' \rangle = (2\pi\hbar)^{-1/2} \exp(i\hbar^{-1}p'x')$, one obtains

$$K(x_b, t; x_a) = \frac{1}{2\pi\hbar} \int dp' \exp\left(i\frac{p'(x_b - x_a) - \mathcal{H}(p')t}{\hbar}\right) . \quad (12.148)$$

For a free particle having mass m , i.e. when $\mathcal{H} = p^2/2m$, the propagator becomes [see Eq. (5.149)]

$$\begin{aligned}
K(x_b, t; x_a) &= \frac{1}{2\pi\hbar} \int dp' \exp\left(i \frac{p'(x_b - x_a) - \frac{p'^2}{2m}t}{\hbar}\right) \\
&= \sqrt{\frac{m}{2\pi i \hbar t}} \exp\left[\frac{im}{2\hbar t}(x_b - x_a)^2\right],
\end{aligned} \tag{12.149}$$

in agreement with Eq. (12.65).

8. With the help of the closure relation $1 = \sum_n |a_n\rangle \langle a_n|$ one finds that the propagator $K(x_b, t; x_a)$ can be expressed as [see Eqs. (4.9) and (12.7)]

$$K(x_b, t; x_a) = \sum_n \exp(-i\hbar^{-1}E_n t) \langle x_b | a_n \rangle \langle a_n | x_a \rangle. \tag{12.150}$$

For a harmonic oscillator the wave functions $\langle x' | a_n \rangle$ are given by [see Eq. (5.134)]

$$\langle x' | a_n \rangle = \frac{\exp\left(-\frac{x'^2}{2x_0^2}\right) H_n\left(\frac{x'}{x_0}\right)}{\pi^{1/4} x_0^{1/2} \sqrt{2^n n!}}. \tag{12.151}$$

where $x_0 = \sqrt{\hbar/m\omega}$, and the energy eigenvalues E_n are given by $E_n = \hbar\omega(n + 1/2)$, thus

$$K(x_b, t; x_a) = \frac{e^{-\frac{x_a^2 + x_b^2}{2x_0^2} - \frac{i\omega t}{2}}}{\pi^{1/2} x_0} \sum_n \frac{\left(\frac{e^{-i\omega t}}{2}\right)^n H_n\left(\frac{x_a}{x_0}\right) H_n\left(\frac{x_b}{x_0}\right)}{n!}. \tag{12.152}$$

With the help of the identity (5.58) one obtains

$$\begin{aligned}
K(x_b, t; x_a) &= \sqrt{\frac{m\omega}{2\pi i \hbar \sin(\omega t)}} \\
&\quad \times \exp\left(\frac{im\omega}{2\hbar \sin(\omega t)} [(x_a^2 + x_b^2) \cos(\omega t) - 2x_a x_b]\right),
\end{aligned} \tag{12.153}$$

in agreement with Eq. (12.115).

9. Assume that the energy eigenstates of the Hamiltonian \mathcal{H} are labeled by $|a_n\rangle$ and the corresponding eigenenergies by E_n , i.e.

$$\mathcal{H} |a_n\rangle = E_n |a_n\rangle, \tag{12.154}$$

where

$$\langle a_{n'} | a_n \rangle = \delta_{nn'}. \tag{12.155}$$

With the help of the closure relation

$$1 = \sum_n |a_n\rangle \langle a_n| , \quad (12.156)$$

one finds that the propagator $K(x_b, t; x_a)$ can be expressed as

$$\begin{aligned} K(x_b, t; x_a) &= \langle x_b | \exp\left(-\frac{i\mathcal{H}t}{\hbar}\right) | x_a \rangle \\ &= \sum_n \langle x_b | a_n \rangle \exp\left(-\frac{iE_n t}{\hbar}\right) \langle a_n | x_a \rangle . \end{aligned} \quad (12.157)$$

Taking $x_b = x_a$ and integrating over x_a yields

$$\int_{-\infty}^{\infty} dx_a K(x_a, t; x_a) = \sum_n \exp\left(-\frac{iE_n t}{\hbar}\right) . \quad (12.158)$$

Thus, the partition function Z , which is given by Eq. (8.35)

$$Z = \sum_n e^{-\beta E_n} , \quad (12.159)$$

where $\beta = 1/(k_B T)$, can be expressed as

$$Z = \int_{-\infty}^{\infty} dx' K(x', -i\hbar\beta; x') . \quad (12.160)$$

10. Using Eq. (8.36) one finds that

$$\langle x'' | \rho | x' \rangle = \frac{\langle x'' | e^{-\beta\mathcal{H}} | x' \rangle}{Z} , \quad (12.161)$$

where the partition function $Z = \text{Tr}(e^{-\beta\mathcal{H}})$ can be expressed in terms of the propagator $K(x'', t; x')$ [see Eq. (12.160)]

$$Z = \int_{-\infty}^{\infty} dx' K(x', -i\hbar\beta; x') . \quad (12.162)$$

Furthermore, as can be seen from the definition of the propagator [see Eq. (12.7)]

$$K(x'', t; x') = \langle x'' | e^{-\frac{i\mathcal{H}t}{\hbar}} | x' \rangle , \quad (12.163)$$

the following holds

$$\langle x'' | e^{-\beta\mathcal{H}} | x' \rangle = K(x'', -i\hbar\beta; x') . \quad (12.164)$$

Thus, with the help of Eq. (12.115) one finds for the case of a harmonic oscillator that (recall that $\sin(ix) = i \sinh x$ and $\cos(ix) = \cosh x$)

$$\begin{aligned}
Z &= \int_{-\infty}^{\infty} dx' K(x', -i\hbar\beta; x') \\
&= \sqrt{\frac{m\omega}{2\pi\hbar \sinh(\beta\hbar\omega)}} \int_{-\infty}^{\infty} dx' \exp\left(-\frac{m\omega [\cosh(\beta\hbar\omega) - 1] x'^2}{\hbar \sinh(\beta\hbar\omega)}\right) \\
&= \sqrt{\frac{1}{2 [\cosh(\beta\hbar\omega) - 1]}} \\
&= \frac{1}{2 \sinh \frac{\beta\hbar\omega}{2}},
\end{aligned} \tag{12.165}$$

and therefore one finds, in agreement with Eq. (8.471), that

$$\begin{aligned}
\langle x'' | \rho | x' \rangle &= \frac{K(x'', -i\hbar\beta; x')}{Z} \\
&= \sinh \frac{\beta\hbar\omega}{2} \sqrt{\frac{2m\omega}{\pi\hbar \sinh(\beta\hbar\omega)}} \\
&\quad \times \exp\left(-\frac{m\omega}{2\hbar \sinh(\beta\hbar\omega)} [(x'^2 + x''^2) \cosh(\beta\hbar\omega) - 2x'x'']\right) \\
&= \frac{e^{-\tanh(\frac{\beta\hbar\omega}{2})\left(\frac{x'+x''}{2x_0}\right)^2 - \coth(\frac{\beta\hbar\omega}{2})\left(\frac{x'-x''}{2x_0}\right)^2}}{x_0 \sqrt{\pi \coth\left(\frac{\beta\hbar\omega}{2}\right)}},
\end{aligned} \tag{12.166}$$

where

$$x_0 = \sqrt{\frac{\hbar}{m\omega}}. \tag{12.167}$$

11. Denoting the state ket vector of the system by $|\psi(t)\rangle$ and the time evolution operator by $u(t)$ one has

$$\begin{aligned}
\psi(x', t) &= \langle x' | \psi(t) \rangle \\
&= \langle x' | u(t) | \psi(0) \rangle \\
&= \int_{-\infty}^{\infty} dx'' \langle x' | u(t) | x'' \rangle \langle x'' | \psi(0) \rangle \\
&= \int_{-\infty}^{\infty} dx'' K(x', t; x'') \psi(x'', 0),
\end{aligned} \tag{12.168}$$

where the propagator $K(x', t; x'')$ is given by Eq. (12.73)

$$K(x', t; x'') = \sqrt{\frac{1}{2\pi i \Omega t x_0^2}} \exp\left[\frac{i}{2\Omega t} \frac{(x' - x'')^2}{x_0^2}\right], \tag{12.169}$$

and where

$$\Omega = \frac{\hbar}{mx_0^2}, \quad (12.170)$$

thus

$$\begin{aligned} \psi(x', t) &= \frac{1}{\pi^{1/4} x_0^{1/2}} \sqrt{\frac{1}{2\pi i \Omega t x_0^2}} \int_{-\infty}^{\infty} dx'' \\ &\times \exp \left[-\frac{1}{2} \left(1 - \frac{i}{\Omega t} \right) \left(\frac{x''}{x_0} \right)^2 - \frac{i}{\Omega t} \frac{x' x''}{x_0^2} + \frac{i}{2\Omega t} \left(\frac{x'}{x_0} \right)^2 \right]. \end{aligned} \quad (12.171)$$

With the help of the identity

$$\frac{1}{\sqrt{\pi}} \int_{-\infty}^{\infty} \exp(-ax^2 + bx + c) dx = \sqrt{\frac{1}{a}} e^{\frac{1}{4} \frac{4ca + b^2}{a}}, \quad (12.172)$$

one finds that

$$\psi(x', t) = \frac{1}{\pi^{1/4} x_0^{1/2}} \sqrt{\frac{1}{1 + i\Omega t}} \exp \left(-\frac{1}{2(1 + i\Omega t)} \left(\frac{x'}{x_0} \right)^2 \right). \quad (12.173)$$

12. The Lagrangian for times $t > 0$ is given by

$$\mathcal{L}(x, \dot{x}) = \frac{1}{2} m \dot{x}^2 - mgx. \quad (12.174)$$

The Euler Lagrange equation yields the classical equation of motion of the system

$$\ddot{x} = -g. \quad (12.175)$$

The general solution reads

$$x = x_0 + v_0 t - \frac{gt^2}{2}, \quad (12.176)$$

where the constants x_0 and v_0 are the initial values of the position and velocity at time $t = 0$. Given that $x = x_a$ at time $t = 0$ and $x = x_b$ at time t one finds that $x_0 = x_a$ and

$$v_0 = \frac{x_b - x_a}{t} + \frac{gt}{2}, \quad (12.177)$$

thus the classical trajectory $x_c(t')$ is given by

$$x_c(t') = x_a + \left(\frac{x_b - x_a}{t} + \frac{g}{2} t \right) t' - \frac{g}{2} t'^2. \quad (12.178)$$

Using the notation

$$x_t = -\frac{gt^2}{2}, \quad (12.179)$$

the trajectory $x_c(t')$ is expressed as

$$x_c(t') = x_a + (x_b - x_a - x_t) \frac{t'}{t} + x_t \frac{t'^2}{t^2}, \quad (12.180)$$

and the corresponding velocity $\dot{x}_c(t')$ is expressed as

$$\dot{x}_c(t') = \frac{x_b - x_a - x_t}{t} + \frac{2x_t t'}{t^2}. \quad (12.181)$$

The Lagrangian along the classical trajectory is given by

$$\begin{aligned} \mathcal{L}(x_c, \dot{x}_c) &= \frac{1}{2}m\dot{x}_c^2 - mgx_c \\ &= \frac{m \left(\frac{x_b - x_a - x_t}{t} + \frac{2x_t t'}{t^2} \right)^2}{2} - mg \left[x_a + (x_b - x_a - x_t) \frac{t'}{t} + x_t \frac{t'^2}{t^2} \right], \end{aligned} \quad (12.182)$$

and the corresponding action S_c is given by

$$\begin{aligned} S_c &= \int_{x_c(t')} dt' \mathcal{L}(x, \dot{x}) \\ &= m \int_0^t dt' \left\{ \frac{\left(\frac{x_b - x_a - x_t}{t} + \frac{2x_t t'}{t^2} \right)^2}{2} - g \left[x_a + (x_b - x_a - x_t) \frac{t'}{t} + x_t \frac{t'^2}{t^2} \right] \right\} \\ &= m \frac{(x_b - x_a)^2 + 2x_t(x_b + x_a) - \frac{x_t^2}{3}}{2t} \end{aligned} \quad (12.183)$$

- a) In general, the propagator in the semiclassical limit is given by Eq. (12.118)

$$K(x_b, t; x_a) = \sqrt{\frac{i}{2\pi\hbar} \frac{d^2 S_c}{dx_a dx_b}} \exp\left(\frac{i}{\hbar} S_c\right), \quad (12.184)$$

where for the present case S_c is given by Eq. (12.183) and

$$\frac{d^2 S_c}{dx_a dx_b} = -\frac{m}{t}, \quad (12.185)$$

thus

$$\begin{aligned}
 K(x_b, t; x_a) &= \sqrt{\frac{m}{2\pi i \hbar t}} \exp\left(\frac{im(x_b - x_a)^2 + 2x_t(x_b + x_a) - \frac{x_t^2}{3}}{2t}\right) \\
 &= \frac{1}{x_0} \sqrt{\frac{1}{2\pi i \omega t}} \exp\left(\frac{i(x_b - x_a)^2 + 2x_t(x_b + x_a) - \frac{x_t^2}{3}}{2x_0^2}\right) \\
 &= \frac{1}{x_0} \sqrt{\frac{1}{2\pi i \omega t}} \exp\left(\frac{i\left(\frac{8}{3}x_t^2 + x_a^2 + 2(2x_t - x_a)(x_b - x_t) + (x_b - x_t)^2\right)}{2x_0^2}\right),
 \end{aligned} \tag{12.186}$$

where

$$x_0 = \sqrt{\frac{\hbar}{m\omega}}. \tag{12.187}$$

b) Initially at time $t = 0$ the wavefunction $\psi(x')$ is given by [see Eq. (5.131)]

$$\psi(x'', t = 0) = \frac{1}{\pi^{1/4} x_0^{1/2}} \exp\left(-\frac{1}{2} \left(\frac{x''}{x_0}\right)^2\right), \tag{12.188}$$

where

$$x_0 = \sqrt{\frac{\hbar}{m\omega}}. \tag{12.189}$$

The wave function at time t is evaluated using the propagator

$$\begin{aligned}
 \psi(x', t) &= \int_{-\infty}^{\infty} dx'' K(x', t; x'') \psi(x'', 0) \\
 &= \frac{1}{x_0} \sqrt{\frac{1}{2\pi i \omega t}} \frac{1}{\pi^{1/4} x_0^{1/2}} \\
 &\quad \times \int_{-\infty}^{\infty} dx'' e^{\frac{i}{\omega t} \frac{\frac{8}{3}x_t^2 + (x'')^2 + 2(2x_t - x'')(x' - x_t) + (x' - x_t)^2}{2x_0^2} - \frac{1}{2} \left(\frac{x''}{x_0}\right)^2} \\
 &= \frac{1}{x_0} \sqrt{\frac{1}{2\pi i \omega t}} \frac{e^{\frac{i}{\omega t} \frac{\frac{8}{3}x_t^2 + 4x_t(x' - x_t) + (x' - x_t)^2}{2x_0^2}}}{\pi^{1/4} x_0^{1/2}} \\
 &\quad \times \int_{-\infty}^{\infty} dx'' e^{-\frac{(1 - \frac{i}{\omega t}) \left(\frac{x''}{x_0}\right)^2}{2} + \frac{-ix''(x' - x_t)}{\omega t x_0^2}}.
 \end{aligned} \tag{12.190}$$

With the help of the identity

$$\frac{1}{\sqrt{\pi}} \int_{-\infty}^{\infty} \exp(-ax^2 + bx) dx = \sqrt{\frac{1}{a}} e^{\frac{b^2}{4a}}, \tag{12.191}$$

one finds that

$$\psi(x', t) = \frac{e^{-\frac{1}{2} \frac{1}{1+i\omega t} \left(\frac{x'-x_t}{x_0}\right)^2 + \frac{8}{3} \frac{i x_t^2 + 4i x_t (x'-x_t)}{2\omega t x_0^2}}}{\pi^{1/4} x_0^{1/2} \sqrt{1+i\omega t}} . \quad (12.192)$$

The probability distribution function $f(x') = |\psi(x', t)|^2$ to find the particle near point x' at time t is thus given by

$$f(x') = \frac{e^{-\frac{1}{1+(\omega t)^2} \left(\frac{x'-x_t}{x_0}\right)^2}}{\sqrt{\pi} x_0 \sqrt{1+(\omega t)^2}} , \quad (12.193)$$

therefore $f(x')$ has a Gaussian distribution with a mean value x_t and variance given by

$$\langle (\Delta x)^2(t) \rangle = \frac{x_0^2}{2} (1 + (\omega t)^2) . \quad (12.194)$$

Note that this result is in agreement with Eq. (5.297).

13. With the help of the propagator K (12.115) one finds that [see Eqs. (3.32) and (12.7)]

$$\begin{aligned} \psi(x_b, t) &= \int_{-\infty}^{\infty} dx_a K(x_b, t; x_a) \psi(x_a, t=0) \\ &= \frac{\sqrt{\frac{1}{2\pi i x_0^2 \sin(\omega t)}}}{\pi^{1/4} x_i^{1/2}} \\ &\quad \times \int_{-\infty}^{\infty} dx_a \exp\left(\frac{i[(x_a^2 + x_b^2) \cos(\omega t) - 2x_a x_b]}{2x_0^2 \sin(\omega t)} - \frac{x_a^2}{2x_i^2}\right) , \end{aligned} \quad (12.195)$$

where

$$x_0 = \sqrt{\frac{\hbar}{m\omega}} , \quad (12.196)$$

thus [see Eq. (5.149)]

$$\psi(x_b, t) = \frac{1}{\pi^{1/4} (\eta x_i)^{1/2}} e^{\frac{i}{2} \left(\frac{\cos(\omega t) - \frac{1}{\eta}}{x_0^2 \sin(\omega t)}\right) x_b^2} , \quad (12.197)$$

where

$$\eta = \frac{i x_0^2 \sin(\omega t)}{x_i^2} + \cos(\omega t) . \quad (12.198)$$

The following holds

$$|\psi(x_b, t)|^2 = \frac{1}{\pi^{1/2} x_f(t)} e^{-\frac{x_b^2}{x_f^2(t)}}, \quad (12.199)$$

where $x_f(t)$, which is given by

$$x_f(t) = x_i (\eta \eta^*)^{1/2} = x_i \sqrt{\frac{x_0^4 \sin^2(\omega t)}{x_i^4} + \cos^2(\omega t)}, \quad (12.200)$$

is the width of the Gaussian wavefunction at time t .

13. Adiabatic Approximation

The adiabatic approximation can be employed for treating systems having slowly varying Hamiltonian. This chapter is mainly based on Ref. [5].

13.1 Momentary Diagonalization

The Schrödinger equation (4.1) is given by

$$i\hbar \frac{d|\alpha\rangle}{dt} = \mathcal{H}|\alpha\rangle . \quad (13.1)$$

For any given value of the time t the Hamiltonian $\mathcal{H}(t)$ is assumed to have a discrete spectrum

$$\mathcal{H}(t)|n(t)\rangle = E_n(t)|n(t)\rangle , \quad (13.2)$$

where $n = 1, 2, \dots$, the momentary eigenenergies $E_n(t)$ are real, and the set of momentary eigenvectors is assumed to be orthonormal

$$\langle n(t)|m(t)\rangle = \delta_{nm} . \quad (13.3)$$

The general solution can be expanded using the momentary eigenvectors as a momentary basis

$$|\alpha(t)\rangle = \sum_n a_n(t) e^{i\beta_n(t)} |n(t)\rangle . \quad (13.4)$$

The phase factors $\beta_n(t)$ in the expansion (13.4) are chosen to be given by

$$\beta_n(t) = \xi_n(t) + \gamma_n(t) , \quad (13.5)$$

where the phase factors

$$\xi_n(t) = -\frac{1}{\hbar} \int^t dt' E_n(t') \quad (13.6)$$

are the so-called dynamical phases, and the other phase factors

$$\gamma_n(t) = i \int^t dt' \langle n(t') | \dot{n}(t') \rangle \quad (13.7)$$

are the so-called geometrical phases. As we will see below, choosing the phase factor $\beta_n(t)$ to be given by Eq. (13.5) ensures that the coefficients $a_n(t)$ become constants in the adiabatic limit.

Exercise 13.1.1. Show that the term $\langle n(t') | \dot{n}(t') \rangle$ is pure imaginary.

Solution 13.1.1. Note that by taking the derivative with respect to t (denoted by upper-dot) of the normalization condition (13.3) one finds that

$$\langle \dot{n} | m \rangle + \langle n | \dot{m} \rangle = 0, \quad (13.8)$$

thus

$$\langle n | \dot{m} \rangle = - \langle m | \dot{n} \rangle^* . \quad (13.9)$$

The last result for the case $n = m$ implies that $\langle n(t') | \dot{n}(t') \rangle$ is pure imaginary, and consequently $\gamma_n(t)$ are pure real.

Substituting Eq. (13.4) into Eq. (13.1) leads to

$$\begin{aligned} & i\hbar \sum_n \dot{a}_n(t) e^{i\beta_n(t)} |n(t)\rangle \\ & - \hbar \sum_n a_n(t) \dot{\beta}_n(t) e^{i\beta_n(t)} |n(t)\rangle \\ & + i\hbar \sum_n a_n(t) e^{i\beta_n(t)} |\dot{n}(t)\rangle \\ & = \sum_n a_n(t) e^{i\beta_n(t)} E_n(t) |n(t)\rangle . \end{aligned} \quad (13.10)$$

Taking the inner product with $\langle m(t) | e^{-i\beta_m(t)}$ yields

$$\dot{a}_m(t) + i\dot{\beta}_m(t) a_m(t) + \sum_n a_n(t) e^{i\beta_n(t)} e^{-i\beta_m(t)} \langle m(t) | \dot{n}(t) \rangle = \frac{E_m(t)}{i\hbar} a_m(t) . \quad (13.11)$$

Since, by definition, the following holds

$$i\dot{\beta}_m(t) = \frac{E_m(t)}{i\hbar} - \langle m(t) | \dot{m}(t) \rangle , \quad (13.12)$$

Eq. (13.11) can be rewritten as

$$\dot{a}_m = - \sum_{n \neq m} e^{i(\beta_n(t) - \beta_m(t))} \langle m(t) | \dot{n}(t) \rangle a_n . \quad (13.13)$$

Exercise 13.1.2. Show that for $n \neq m$ the following holds

$$\langle m(t) | \dot{n}(t) \rangle = \frac{\langle m(t) | \dot{\mathcal{H}} | n(t) \rangle}{E_n(t) - E_m(t)}. \quad (13.14)$$

Solution 13.1.2. Taking the time derivative of Eq. (13.2)

$$\dot{\mathcal{H}} |n\rangle + \mathcal{H} |\dot{n}\rangle = \dot{E}_n |n\rangle + E_n |\dot{n}\rangle, \quad (13.15)$$

and the inner product with $\langle m(t) |$, where $m \neq n$, yields the desired identity.

13.2 Gauge Transformation

The momentary orthonormal basis $\{|n(t')\rangle\}_n$, which is made of eigenvectors of $\mathcal{H}(t)$, is clearly not singly determined. Consider the following ‘gauge transformation’ [see for comparison Eq. (12.49)]

$$|n(t')\rangle \rightarrow |\tilde{n}(t')\rangle = e^{-i\Lambda(t')} |n(t')\rangle, \quad (13.16)$$

where $\Lambda(t')$ is arbitrary real function of time. The geometrical phase $\gamma_n(t)$, which is given by Eq. (13.7)

$$\gamma_n(t) = i \int_{t_0}^t dt' \langle n(t') | \dot{n}(t') \rangle, \quad (13.17)$$

is transformed into

$$\gamma_n(t) \rightarrow \tilde{\gamma}_n(t) = \gamma_n(t) + \Lambda(t) - \Lambda(t_0). \quad (13.18)$$

Thus, in general the geometrical phase is not singly determined. However, it becomes singly determined, and thus gauge invariant, if the path is closed, namely if $\mathcal{H}(t) = \mathcal{H}(t_0)$, since for such a case $\Lambda(t) = \Lambda(t_0)$.

13.3 Adiabatic Limit

In the adiabatic limit the terms $\langle m(t) | \dot{n}(t) \rangle$ are considered to be negligibly small. As can be seen from Eq. (13.14), this limit corresponds to the case where the rate of change in time of the Hamiltonian approaches zero. In this limit the coefficients $a_n(t)$ become constants [see Eq. (13.13)], and the solution (13.4) thus becomes

$$|\alpha(t)\rangle = \sum_n a_n e^{i\beta_n(t)} |n(t)\rangle. \quad (13.19)$$

13.4 The Case of Two-Dimensional Hilbert Space

In this case the Hilbert space is two-dimensional and the Hamiltonian can be represented by a 2×2 matrix, which is conveniently expressed as a combination of Pauli matrices

$$\mathcal{H} \doteq h_0 I + \mathbf{h} \cdot \boldsymbol{\sigma} , \quad (13.20)$$

where I is the 2×2 identity matrix, h_0 is a real scalar, $\mathbf{h} = (h_1, h_2, h_3)$ is a three-dimensional real vector, and the components of the Pauli matrix vector $\boldsymbol{\sigma}$ are given by

$$\sigma_1 = \begin{pmatrix} 0 & 1 \\ 1 & 0 \end{pmatrix}, \quad \sigma_2 = \begin{pmatrix} 0 & -i \\ i & 0 \end{pmatrix}, \quad \sigma_3 = \begin{pmatrix} 1 & 0 \\ 0 & -1 \end{pmatrix} . \quad (13.21)$$

Using the notation $\mathbf{h} = H \hat{\mathbf{h}}$, where $H = \sqrt{\mathbf{h} \cdot \mathbf{h}}$, and where $\hat{\mathbf{h}}$ is a unit vector, given in spherical coordinates by

$$\hat{\mathbf{h}} = (\cos \varphi \sin \theta, \sin \varphi \sin \theta, \cos \theta) , \quad (13.22)$$

one finds that

$$\mathcal{H} \doteq h_0 I + H \begin{pmatrix} \cos \theta & \sin \theta \exp(-i\varphi) \\ \sin \theta \exp(i\varphi) & -\cos \theta \end{pmatrix} . \quad (13.23)$$

The orthonormal eigenvectors are chosen to be given by [see Eqs. (6.301) and (6.302)]

$$|+\rangle \doteq \begin{pmatrix} \cos \frac{\theta}{2} \exp(-\frac{i\varphi}{2}) \\ \sin \frac{\theta}{2} \exp(\frac{i\varphi}{2}) \end{pmatrix} , \quad (13.24)$$

$$|-\rangle \doteq \begin{pmatrix} -\sin \frac{\theta}{2} \exp(-\frac{i\varphi}{2}) \\ \cos \frac{\theta}{2} \exp(\frac{i\varphi}{2}) \end{pmatrix} , \quad (13.25)$$

and the following holds $\langle +|+\rangle = \langle -|-\rangle = 1$, $\langle +|-\rangle = 0$, and

$$\mathcal{H} |\pm\rangle = (h_0 \pm H) |\pm\rangle . \quad (13.26)$$

Note that the eigenstates $|\pm\rangle$ are independent of both h_0 and H .

The geometrical phase (13.7) can be evaluated by integration along the path $\mathbf{h}(t)$

$$\gamma_n(t) = i \int_0^t dt' \langle n(t') | \dot{n}(t') \rangle = i \int_{\mathbf{h}(0)}^{\mathbf{h}(t)} d\mathbf{h} \cdot \langle n(\mathbf{h}) | \nabla_{\mathbf{h}} | n(\mathbf{h}) \rangle . \quad (13.27)$$

Exercise 13.4.1. Show that

$$\langle \pm | \nabla_{\mathbf{h}} | \pm \rangle = \mp \frac{i\hat{\varphi}}{2H} \text{ctg } \theta . \quad (13.28)$$

Solution 13.4.1. Using the expression for a gradient in spherical coordinates (the radial coordinate r in the present case is H)

$$\nabla f = \frac{\partial f}{\partial r} \hat{\mathbf{r}} + \frac{1}{r} \frac{\partial f}{\partial \theta} \hat{\boldsymbol{\theta}} + \frac{1}{r \sin \theta} \frac{\partial f}{\partial \varphi} \hat{\boldsymbol{\varphi}}, \quad (13.29)$$

one finds that

$$\nabla_{\mathbf{h}} |+\rangle = \frac{\hat{\boldsymbol{\theta}}}{2H} \begin{pmatrix} -\sin \frac{\theta}{2} \exp\left(-\frac{i\varphi}{2}\right) \\ \cos \frac{\theta}{2} \exp\left(\frac{i\varphi}{2}\right) \end{pmatrix} + \frac{i\hat{\boldsymbol{\varphi}}}{2H \sin \theta} \begin{pmatrix} -\cos \frac{\theta}{2} \exp\left(-\frac{i\varphi}{2}\right) \\ \sin \frac{\theta}{2} \exp\left(\frac{i\varphi}{2}\right) \end{pmatrix}, \quad (13.30)$$

thus

$$\begin{aligned} \langle + | \nabla_{\mathbf{h}} | + \rangle &= \frac{i\hat{\boldsymbol{\varphi}}}{2H \sin \theta} \left(\cos \frac{\theta}{2} \exp\left(\frac{i\varphi}{2}\right) \sin \frac{\theta}{2} \exp\left(-\frac{i\varphi}{2}\right) \right) \begin{pmatrix} -\cos \frac{\theta}{2} \exp\left(-\frac{i\varphi}{2}\right) \\ \sin \frac{\theta}{2} \exp\left(\frac{i\varphi}{2}\right) \end{pmatrix} \\ &= -\frac{i\hat{\boldsymbol{\varphi}}}{2H} \operatorname{ctg} \theta. \end{aligned} \quad (13.31)$$

The term $\langle - | \nabla_{\mathbf{h}} | - \rangle$ is calculated in a similar way.

For the case of a close path, Stock's theorem can be used to express the integral in terms of a surface integral over the surface bounded by the close curve $\mathbf{h}(t)$

$$\gamma_n = i \oint d\mathbf{h} \cdot \langle n | \nabla_{\mathbf{h}} | n \rangle = i \int_S d\mathbf{a} \cdot (\nabla \times \langle n | \nabla_{\mathbf{h}} | n \rangle). \quad (13.32)$$

Exercise 13.4.2. Show that

$$\nabla \times \langle \pm | \nabla_{\mathbf{h}} | \pm \rangle = \pm \frac{i\mathbf{h}}{2|\mathbf{h}|^3}. \quad (13.33)$$

Solution 13.4.2. Using the general expression for the curl operator in spherical coordinates (again, note that the radial coordinate r in the present case is H)

$$\begin{aligned} \nabla \times \mathbf{A} &= \frac{1}{r \sin \theta} \left(\frac{\partial(\sin \theta A_\varphi)}{\partial \theta} - \frac{\partial A_\theta}{\partial \varphi} \right) \hat{\mathbf{r}} \\ &\quad + \frac{1}{r} \left(\frac{1}{\sin \theta} \frac{\partial A_r}{\partial \varphi} - \frac{\partial}{\partial r} (r A_\varphi) \right) \hat{\boldsymbol{\theta}} \\ &\quad + \frac{1}{r} \left(\frac{\partial(r A_\theta)}{\partial r} - \frac{\partial A_r}{\partial \theta} \right) \hat{\boldsymbol{\varphi}}, \end{aligned} \quad (13.34)$$

one finds that

$$\nabla \times \langle \pm | \nabla_{\mathbf{h}} | \pm \rangle = \mp \frac{i\hat{\mathbf{h}}}{2H^2 \sin \theta} \frac{\partial \cos \theta}{\partial \theta} = \mp \frac{i\mathbf{h}}{2|\mathbf{h}|^3}. \quad (13.35)$$

With the help of the last result one thus finds that

$$\gamma_{\pm} = \mp \frac{1}{2} \int_S d\mathbf{a} \cdot \frac{\mathbf{h}}{|\mathbf{h}|^3} = \mp \frac{1}{2} \Omega, \quad (13.36)$$

where Ω is the solid angle subtended by the close path $\mathbf{h}(t)$ as seen from the origin. Due to the geometrical nature of the last result, these phase factors were given the name geometrical phases.

13.5 Transition Probability

The set of equations of motion (13.13) can be rewritten in a matrix form as

$$i \frac{d}{dt} |a\rangle = H |a\rangle, \quad (13.37)$$

where

$$|a\rangle = \begin{pmatrix} a_1 \\ a_2 \\ \vdots \end{pmatrix} \quad (13.38)$$

is a column vector of the coefficients $a_n \in \mathcal{C}$, and where the matrix elements of H are given by

$$H_{mn} = H_{nm}^* = -ie^{i(\beta_n(t) - \beta_m(t))} \langle m(t) | \dot{n}(t) \rangle \quad (13.39)$$

for the case $n \neq m$ and $H_{nn} = 0$ otherwise.

The inner product between the vectors

$$|a\rangle = \begin{pmatrix} a_1 \\ a_2 \\ \vdots \end{pmatrix}, \quad |b\rangle = \begin{pmatrix} b_1 \\ b_2 \\ \vdots \end{pmatrix}, \quad (13.40)$$

is defined by

$$(a | b) = (b | a)^* = \sum_m a_m^* b_m. \quad (13.41)$$

The set of vectors $\{|n\rangle\}$ ($n = 1, 2, \dots$), having coefficients $a_m = \delta_{nm}$, forms an orthonormal basis for the vector space

$$(n_1 | n_2) = \delta_{n_1 n_2}. \quad (13.42)$$

Consider the case where the system is initially at time t_0 in the state $|n\rangle$. What is the probability $p_{nn}(t)$ to find it later at time $t > t_0$ at the same state $|n\rangle$? The adiabatic approximation is valid only when $p_{nn} \simeq 1$. Considering the matrix H as a perturbation, the probability p_{nn} can be approximated using time dependent perturbation theory.

Exercise 13.5.1. Show that to lowest nonvanishing order the following holds

$$p_{nn}(t) = 1 - \sum_m \left| \int_{t_0}^t dt' H_{nm}(t') \right|^2 . \quad (13.43)$$

Solution 13.5.1. By employing Eqs. (10.21) and (10.27) one finds that (recall that $H_{nn} = 0$)

$$p_{nn}(t) = 1 - \int_{t_0}^t dt' \int_{t_0}^t dt'' \langle n | H(t') H(t'') | n \rangle . \quad (13.44)$$

Inserting the identity operator $1 = \sum_m |m\rangle \langle m|$ between $H(t')$ and $H(t'')$ and recalling that $H_{mn} = H_{nm}^*$ lead to [compare with Eq. (10.29)]

$$p_{nn}(t) = 1 - \sum_m p_{mn}(t) , \quad (13.45)$$

where

$$p_{mn}(t) = \left| \int_{t_0}^t dt' H_{nm}(t') \right|^2 . \quad (13.46)$$

As can be seen from Eq. (13.39), the matrix elements $H_{nm}(t')$ are proportional to the oscillatory dynamical phase factors

$$H_{mn} \propto \exp(i(\xi_n(t) - \xi_m(t))) = \exp\left(-\frac{i}{\hbar} \int^{t'} dt'' (E_n(t'') - E_m(t''))\right) . \quad (13.47)$$

In the adiabatic limit these terms rapidly oscillate and consequently the probabilities $p_{mn}(t)$ are exponentially small. From the same reason, the dominant contribution to the integral is expected to come from regions where the energy gap $E_n(t') - E_m(t')$ is relatively small. Moreover, it is also expected that the main contribution to the total 'survival' probability p_{nn} will come from those states whose energy $E_m(t')$ is close to $E_n(t')$. Having this in mind, we study below the transition probability for the case of a two level system. As we will see below, the main contribution indeed comes from the region near the point where the energy gap obtains a minimum.

13.5.1 The Case of Two-Dimensional Hilbert Space

We calculate below p_{-+} for the case $\mathcal{H} \doteq \mathbf{h} \cdot \boldsymbol{\sigma}$, where $\mathbf{h}(t)$ is the straight line

$$\mathbf{h}(t) = \hbar\Omega(0, 1, \gamma t) , \quad (13.48)$$

where Ω is a positive constant, γ is a real constant, and where the initial time is taken to be $t_0 = -\infty$ and the final one is taken to be $t = \infty$. In spherical coordinates $\mathbf{h}(t)$ is given by

$$\mathbf{h}(t) = H(0, \sin \theta, \cos \theta), \quad (13.49)$$

where

$$H = \hbar\Omega\sqrt{1 + (\gamma t)^2}, \quad (13.50)$$

$$\cot \theta = \gamma t, \quad (13.51)$$

and where $\varphi = \pi/2$. Thus, the energy gap $2H$ obtains a minimum at time $t = 0$. As can be seen from Eqs. (13.24) and (13.25), for any curve lying on a plane with a constant azimuthal angle φ , the following holds

$$|\dot{+}\rangle = \frac{\dot{\theta}}{2} |-\rangle, \quad (13.52)$$

and therefore

$$\langle - | \dot{+} \rangle = \frac{\dot{\theta}}{2}, \quad (13.53)$$

and

$$\langle + | \dot{+} \rangle = \langle - | \dot{-} \rangle = 0. \quad (13.54)$$

For the present case one finds using Eq. (13.51) that

$$\langle - | \dot{+} \rangle = -\frac{1}{2} \frac{\gamma}{1 + (\gamma t)^2}. \quad (13.55)$$

This together with Eqs. (13.39) and (13.46) leads to

$$\begin{aligned} p_{-+} &= \left| \int_{-\infty}^{\infty} dt' e^{i(\xi_+(t') - \xi_-(t'))} \langle - (t') | \dot{+} (t') \rangle \right|^2 \\ &= \left| \frac{\gamma}{2} \int_{-\infty}^{\infty} dt' \frac{\exp\left(-2i\Omega \int_0^{t'} dt'' \sqrt{1 + (\gamma t'')^2}\right)}{1 + (\gamma t')^2} \right|^2 \\ &= \left| \frac{\gamma}{2} \int_{-\infty}^{\infty} dt' \frac{\exp\left(-\frac{2i\Omega}{\gamma} \int_0^{\gamma t'} d\tau \sqrt{1 + \tau^2}\right)}{1 + (\gamma t')^2} \right|^2 \\ &= \left| \frac{1}{2} \int_{-\infty}^{\infty} d\tau \frac{\exp\left\{-\frac{i\Omega}{\gamma} [\tau\sqrt{1 + \tau^2} - \ln(-\tau + \sqrt{1 + \tau^2})]\right\}}{1 + \tau^2} \right|^2. \end{aligned} \quad (13.56)$$

Exercise 13.5.2. Show that if $\gamma/\Omega \ll 1$ then

$$p_{-+} \simeq \exp\left(-\pi \frac{\Omega}{\gamma}\right). \quad (13.57)$$

Solution 13.5.2. The variable transformation

$$\tau = \sinh z, \quad (13.58)$$

and the identities

$$\sqrt{1 + \tau^2} = \cosh z, \quad (13.59)$$

$$\tau \sqrt{1 + \tau^2} = \frac{1}{2} \sinh(2z), \quad (13.60)$$

$$\ln\left(-\tau + \sqrt{1 + \tau^2}\right) = -z, \quad (13.61)$$

$$d\tau = \cosh z \, dz, \quad (13.62)$$

yield

$$p_{-+} = \left| \frac{1}{2} \int_{-\infty}^{\infty} dz \frac{\exp\left[-\frac{i\Omega}{\gamma} \left(\frac{1}{2} \sinh(2z) + z\right)\right]}{\cosh z} \right|^2. \quad (13.63)$$

In the limit $\gamma/\Omega \ll 1$ the phase oscillates rapidly and consequently $p_{-+} \rightarrow 0$. The stationary phase points z_n in the complex plane are found from the condition

$$0 = \frac{d}{dz} \left(\frac{1}{2} \sinh 2z + z \right) = \cosh 2z + 1, \quad (13.64)$$

thus

$$z_n = i\pi \left(n + \frac{1}{2} \right), \quad (13.65)$$

where n is integer. Note, however that the term $1/\cosh z$ has poles at the same points. Using the Cauchy's theorem the path of integration can be deformed to pass close to the point $z_{-1} = -i\pi/2$. Since the pole at z_{-1} is a simple one, the principle value of the integral exists. To avoid passing through the pole at z_{-1} a trajectory forming a half circle "above" the pole with radius ε is chosen where $\varepsilon \rightarrow 0$. This section gives the dominant contribution which is $i\pi R$, where R is the residue at the pole. Thus the probability p_{-+} is approximately given by

$$p_{-+} \simeq \exp\left(-\pi \frac{\Omega}{\gamma}\right). \quad (13.66)$$

The last result can be used to obtain a validity condition for the adiabatic approximation. In the adiabatic limit $p_{-+} \ll 1$, and thus the condition $\pi\Omega/\gamma \gg 1$ is required to ensure the validity of the approximation.

13.6 Slow and Fast Coordinates

Consider a system whose Hamiltonian is given by

$$\mathcal{H} = \mathcal{H}_0 + \mathcal{H}_1 . \quad (13.67)$$

The Hamiltonian \mathcal{H}_0 is assumed to depend on a set of coordinates $\bar{x} = (x_1, x_2, \dots)$ and on their canonically conjugate variables $\bar{p} = (p_1, p_2, \dots)$, i.e. $\mathcal{H}_0 = \mathcal{H}_0(\bar{x}, \bar{p})$. In what follows the coordinates $\bar{x} = (x_1, x_2, \dots)$ will be considered as slow, and thus \mathcal{H}_0 will be considered as the Hamiltonian of the slow subsystem. The other part of the system is a fast subsystem, which is assumed to have a much faster dynamics and its energy spectrum is assumed to be discrete. The Hamiltonian of the fast subsystem \mathcal{H}_1 is assumed to parametrically depend on the slow degrees of freedom \bar{x} , i.e. $\mathcal{H}_1 = \mathcal{H}_1(\bar{x})$. This dependence gives rise to the coupling between the slow and fast subsystems.

An adiabatic approximation can be employed in order to simplify the equations of motion of the combined system. In what follows, for simplicity, this method will be demonstrated for the case where the slow subsystem is assumed to be composed of a set of decoupled harmonic oscillators. For this case the Hamiltonian \mathcal{H}_0 is taken to be given by

$$\mathcal{H}_0 = \sum_l \left(\frac{p_l^2}{2m_l} + \frac{m_l \omega_l^2 x_l^2}{2} \right) , \quad (13.68)$$

where m_l and ω_l are the mass and angular frequency of mode l , respectively.

The Hamiltonian of the fast subsystem $\mathcal{H}_1(\bar{x})$, which depends parametrically on \bar{x} , has a set of eigenvectors and corresponding eigenvalues for any given value of \bar{x}

$$\mathcal{H}_1 |n(\bar{x})\rangle = \varepsilon_n(\bar{x}) |n(\bar{x})\rangle , \quad (13.69)$$

where $n = 1, 2, \dots$. The set of 'local' eigenvectors $\{|n(\bar{x})\rangle\}$ is assumed to form an orthonormal basis of the Hilbert space of the fast subsystem, and thus the following is assumed to hold

$$\langle m(\bar{x}) | n(\bar{x}) \rangle = \delta_{mn} , \quad (13.70)$$

and [see Eq. (2.23)]

$$\sum_k |k(\bar{x})\rangle \langle k(\bar{x})| = 1_{\text{F}} , \quad (13.71)$$

where 1_{F} is the identity operator on the Hilbert space of the fast subsystem.

The state of the entire system $\psi(t)$ at time t is expanded at any point \bar{x} using the 'local' basis $\{|n(\bar{x})\rangle\}$

$$\psi(t) = \sum_n \xi_n(\bar{x}, t) |n(\bar{x})\rangle . \quad (13.72)$$

In the above expression a mixed notation is being employed. On one hand, the ket notation is used to denote the state of the fast subsystem (the terms $|n(\bar{x})\rangle$). On the other hand, a wavefunction in the position representation (the terms $\xi_n(\bar{x}, t)$) is employed to denote the state of the slow subsystem.

Substituting the expansion (13.72) into the Schrödinger equation (4.1)

$$i\hbar \frac{d\psi}{dt} = \mathcal{H}\psi , \quad (13.73)$$

leads to

$$\sum_n [\mathcal{H}_0 + \varepsilon_n(\bar{x})] \xi_n(\bar{x}, t) |n(\bar{x})\rangle = i\hbar \sum_n \dot{\xi}_n(\bar{x}, t) |n(\bar{x})\rangle , \quad (13.74)$$

where overdot represents time derivative. Projecting $\langle m(\bar{x})|$ leads to

$$\sum_n \langle m(\bar{x})| \mathcal{H}_0 \xi_n(\bar{x}, t) |n(\bar{x})\rangle + \varepsilon_m(\bar{x}) \xi_m(\bar{x}, t) = i\hbar \dot{\xi}_m(\bar{x}, t) . \quad (13.75)$$

By calculating the term [see Eq. (13.70)]

$$\begin{aligned} \langle m(\bar{x})| p_l^2 \xi_n(\bar{x}, t) |n(\bar{x})\rangle &= \xi_n(\bar{x}, t) \langle m(\bar{x})| p_l^2 |n(\bar{x})\rangle \\ &+ 2 \langle p_l \xi_n(\bar{x}, t) | m(\bar{x}) | p_l | n(\bar{x})\rangle + \delta_{mn} p_l^2 \xi_n(\bar{x}, t) , \end{aligned} \quad (13.76)$$

introducing the notation

$$A_{m,n;l} \equiv - \langle m(\bar{x})| p_l | n(\bar{x})\rangle , \quad (13.77)$$

and using [see Eq. (13.71)]

$$\begin{aligned} \langle m(\bar{x})| p_l^2 | n(\bar{x})\rangle &= \sum_k \langle m(\bar{x})| p_l | k(\bar{x})\rangle \langle k(\bar{x})| p_l | n(\bar{x})\rangle \\ &= -p_l A_{m,n;l} + \sum_k A_{m,k;l} A_{k,n;l} , \end{aligned} \quad (13.78)$$

one obtains

$$\begin{aligned} &\langle m(\bar{x})| p_l^2 \xi_n(\bar{x}, t) | n(\bar{x})\rangle \\ &= \xi_n(\bar{x}, t) \left(-p_l A_{m,n;l} + \sum_k A_{m,k;l} A_{k,n;l} \right) \\ &- 2A_{m,n;l} p_l \xi_n(\bar{x}, t) + \delta_{mn} p_l^2 \xi_n(\bar{x}, t) . \end{aligned} \quad (13.79)$$

With the help of Eqs. (13.68) and (13.75) one finds that

$$\begin{aligned}
 & \sum_l \frac{1}{2m_l} \sum_n \xi_n(\bar{x}, t) \left(-p_l A_{m,n;l} + \sum_k A_{m,k;l} A_{k,n;l} \right) \\
 & - \sum_l \frac{1}{2m_l} \sum_n [-2A_{m,n;l} p_l \xi_n(\bar{x}, t) + \delta_{mn} p_l^2 \xi_n(\bar{x}, t)] \\
 & + \sum_l \frac{m_l \omega_l^2 x_l^2}{2} \xi_m(\bar{x}, t) + \varepsilon_m(\bar{x}) \xi_m(\bar{x}, t) = i\hbar \dot{\xi}_m(\bar{x}, t) .
 \end{aligned} \tag{13.80}$$

Defining the matrices $(\hat{A}_l)_{m,n} = A_{m,n;l}$, $(\hat{\varepsilon})_{m,n} = \varepsilon_m \delta_{mn}$, and the vector $(\check{\xi})_n = \xi_n$, the above can be written in a matrix form as

$$\left\{ \sum_l \left[\frac{1}{2m_l} (p_l - \hat{A}_l)^2 + \frac{m_l \omega_l^2 x_l^2}{2} \right] + \hat{\varepsilon} \right\} \check{\xi} = i\hbar \dot{\check{\xi}} . \tag{13.81}$$

To calculate the off-diagonal matrix elements of \hat{A}_l we apply p_l to Eq. (13.69) and project $\langle m(\bar{x})|$, where $m \neq n$

$$\langle m(\bar{x})| p_l \mathcal{H}_1 |n(\bar{x})\rangle = \langle m(\bar{x})| p_l \varepsilon_n(\bar{x}) |n(\bar{x})\rangle . \tag{13.82}$$

Using Eq. (13.70), the definition (13.77) and $p_l = -i\hbar \frac{\partial}{\partial x_l}$ [see Eq. (3.29)] one finds that [compare with Eq. (13.14)]

$$A_{m,n;l} = i\hbar \frac{\langle m(\bar{x})| \frac{\partial \mathcal{H}_1}{\partial x_l} |n(\bar{x})\rangle}{\varepsilon_n - \varepsilon_m} . \tag{13.83}$$

In the adiabatic approximation the off diagonal elements of \hat{A}_l [see Eq. (13.83)] are considered as negligible small. In this case the set of equations of motion (13.81) becomes decoupled

$$i\hbar \dot{\xi}_m = \left\{ \sum_l \left[\frac{(p_l - A_{m,m;l}(\bar{x}))^2}{2m_l} + \frac{m_l \omega_l^2 x_l^2}{2} \right] + \varepsilon_m(\bar{x}) \right\} \xi_m . \tag{13.84}$$

As can be seen from the above result (13.84), the adiabatic approximation greatly simplifies the system's equations of motion. The effect of the fast subsystem on the dynamics of the slow one is taken into account by adding a vector potential $A_{m,m;l}(\bar{x})$ and a scalar potential $\varepsilon_m(\bar{x})$ to the Schrödinger equation of the slow subsystem [compare with Eq. (4.268)]. However, both potential terms depend on the state m that is being occupied by the fast subsystem.

Exercise 13.6.1. Show that if $\langle m(\bar{x})| \partial/\partial x_l |m(\bar{x})\rangle$ is pure real then

$$A_{mm;l}(\bar{x}) = 0 . \tag{13.85}$$

Solution 13.6.1. Note that in general the diagonal elements $A_{m,m;l}$ are real since p_l is Hermitian [see Eq. (13.77)]. On the other hand, if $\langle m(\bar{x}) | \partial / \partial x_l | m(\bar{x}) \rangle$ is pure real then $A_{mm;l}(\bar{x})$ is pure imaginary, thus for this case $A_{mm;l}(\bar{x}) = 0$.

13.7 Problems

1. Consider a particle having mass m moving in a time dependent one-dimensional double well potential given by

$$V(x;t) = -\alpha [\delta(x-vt) + \delta(x+vt)] , \quad (13.86)$$

where x is position, t is time, both α and v are positive, and δ denotes the delta function. The first (second) well is located at $x = vt$ ($x = -vt$), and the velocity v is assumed to be small. Assume that initially, at time $t_0 \rightarrow -\infty$, the particle occupies the bound state of the first well. Calculate the probability that the particle will remain bounded after time $t = 0$, when the two wells collide.

2. Consider the time dependent spin 1/2 Hamiltonian

$$\mathcal{H} \doteq \frac{\hbar}{2} \begin{pmatrix} \omega_0 & \omega_1 \exp(-i\omega t) \\ \omega_1 \exp(i\omega t) & -\omega_0 \end{pmatrix} , \quad (13.87)$$

where ω_0 , ω_1 and ω are real constants. Let $u(t)$ be the exact time evolution operator associated with the Hamiltonian \mathcal{H} .

- a) Calculate the time evolution operator $u_1 = u(\tau)$, where $\tau = 2\pi/\omega$ (note that the Hamiltonian \mathcal{H} is periodic, and the period time is τ).
 - b) Calculate the eigenvalues q_+ and q_- of u_1 .
 - c) Compare the result for q_{\pm} with the dynamical and geometrical phases of the adiabatic approximation for this case.
3. Consider the following 'gauge transformation'

$$|+\rangle \doteq \begin{pmatrix} \cos \frac{\theta}{2} \exp\left(-\frac{i\varphi}{2}\right) \\ \sin \frac{\theta}{2} \exp\left(\frac{i\varphi}{2}\right) \end{pmatrix} \rightarrow |\tilde{+}\rangle \doteq \begin{pmatrix} \cos \frac{\theta}{2} \\ \sin \frac{\theta}{2} \exp(i\varphi) \end{pmatrix} , \quad (13.88)$$

$$|-\rangle \doteq \begin{pmatrix} -\sin \frac{\theta}{2} \exp\left(-\frac{i\varphi}{2}\right) \\ \cos \frac{\theta}{2} \exp\left(\frac{i\varphi}{2}\right) \end{pmatrix} \rightarrow |\tilde{-}\rangle \doteq \begin{pmatrix} -\sin \frac{\theta}{2} \\ \cos \frac{\theta}{2} \exp(i\varphi) \end{pmatrix} . \quad (13.89)$$

Find an expression for the transformed geometrical phase $\tilde{\gamma}_{\pm}(t)$.

4. The geometrical phase γ_{\pm} given by Eq. (13.36) was derived for the case of a spin $s = 1/2$ (which is a two-level system). Generalize this result by showing that for a general spin s (integer or half integer) the geometrical phase corresponding to the quantum magnetic number $m \in \{-s, -s+1, \dots, s\}$ [see Eq. (6.68)] is given by

$$\gamma_m = -m\Omega , \quad (13.90)$$

where Ω is the solid angle subtended by the magnetic field close path $\mathbf{B}(t)$ as seen from the origin.

5. Consider a particle having mass m confined by a time dependent potential well given by

$$V(x) = \begin{cases} 0 & \text{if } 0 \leq x \leq a \\ \infty & \text{if } x < 0 \text{ or } x > a \end{cases} . \quad (13.91)$$

where the width of the well a oscillates in time according to

$$a(t) = a_0 (1 - \alpha \sin^2(\omega_p t)) , \quad (13.92)$$

where a_0 , α and ω_p are positive, and where $\alpha < 1$.

- a) Under what condition the adiabatic approximation is expected to be valid.
 - b) Calculate the geometrical phases γ_n [see Eq. (13.7)] for a cyclic evolution from time $t = 0$ to time $t = \pi/\omega_p$.
6. Consider a particle of mass m moving in one dimension along the x axis, whose time-dependent Hamiltonian $\mathcal{H}(t')$ is given by

$$\mathcal{H}(t') = \frac{p^2}{2m} + \frac{m\omega_0^2 x^2}{2} + x f(t') , \quad (13.93)$$

where p is the variable canonically conjugate to x , the force $f(t')$ is given by

$$f(t') = \lambda \frac{\exp\left(-\frac{t'^2}{\tau^2}\right)}{\sqrt{\pi}\tau} , \quad (13.94)$$

and ω_0 , λ and τ are real constants. When τ is sufficiently large the problem can be treated using the adiabatic approximation. Expand the state of the system $|\psi(t)\rangle$ in a basis of momentary eigenvectors of the Hamiltonian $\mathcal{H}(t')$ and derive the equations of motion for the coefficients in that basis. The system is initially prepared, at time $t \rightarrow -\infty$, in the ground state of the momentary Hamiltonian $\lim_{t \rightarrow -\infty} \mathcal{H}(t)$. Using the equations of motion for the coefficients in the momentary basis calculate to lowest nonvanishing order in the adiabatic approximation the transition probability p_{n0} to any of the momentary eigenvectors of the Hamiltonian $\lim_{t \rightarrow \infty} \mathcal{H}(t)$ in the limit $t \rightarrow \infty$.

7. Consider a particle having mass m in a two-dimensional infinite potential well given by

$$V(x, y) = \begin{cases} 0 & \frac{x^2}{X_0^2} + \frac{y^2}{Y_0^2} \leq 1 \\ \infty & \frac{x^2}{X_0^2} + \frac{y^2}{Y_0^2} > 1 \end{cases} , \quad (13.95)$$

where X_0 and Y_0 are positive. Calculate approximately the low lying energy eigenvalues in the limit where $X_0 \gg Y_0$.

8. **Quantum geometric tensor** - Let $\mathcal{H}(\mathbf{s})$ be a Hamiltonian that smoothly depends on a vector of real parameters $\mathbf{s} = (s_1, s_2, \dots, s_N)$. The normalized energy eigenvectors of $\mathcal{H}(\mathbf{s})$ are denoted by $|n(\mathbf{s})\rangle$, and the correspondingly eigenenergies (which are assumed to be non-degenerate) by $E_n(\mathbf{s})$. The quantum geometric tensor $T_{n,\mu\nu}(\mathbf{s})$ is defined by

$$\begin{aligned} T_{n,\mu\nu} &= \langle \partial_\mu n | (1 - |n\rangle \langle n|) | \partial_\nu n \rangle \\ &= T'_{n,\mu\nu} + iT''_{n,\mu\nu}, \end{aligned} \quad (13.96)$$

where ∂_ν represents a derivative with respect to s_ν , i.e.

$$|\partial_\nu n\rangle = \frac{\partial}{\partial s_\nu} |n\rangle, \quad (13.97)$$

and where $T'_{n,\mu\nu} = \text{Re}(T_{n,\mu\nu})$ and $T''_{n,\mu\nu}(\mathbf{s}) = \text{Im}(T_{n,\mu\nu})$.

- a) Show that

$$1 - |\langle n(\mathbf{s}) | n(\mathbf{s} + d\mathbf{s}) \rangle|^2 = \sum_{\mu\nu} T'_{n,\mu\nu} ds_\mu ds_\nu + O(|d\mathbf{s}|^3). \quad (13.98)$$

Note that the above result suggests that the quantum geometric tensor can be used in order to characterize distances between nearby vectors in the Hilbert space.

- b) Show that $T_{n,ij}(\mathbf{s})$ is invariant under the transformation $|n(\mathbf{s}')\rangle \rightarrow |\tilde{n}(\mathbf{s}')\rangle = e^{-i\Lambda(\mathbf{s}')} |n(\mathbf{s}')\rangle$ [see Eq. (13.16)], where $\Lambda(\mathbf{s}')$ is an arbitrary real function.
- c) Calculate the quantum geometric tensor $T_{\pm,\mu\nu}(\mathbf{s})$ for the two-level Hamiltonian given by Eq. (13.23). For this case the vector of parameters is given by $\mathbf{s} = (\theta, \varphi)$, where θ and φ are angles in spherical coordinates.

13.8 Solutions

1. The bound state of the first (second) well at time t is denoted by $|1(t)\rangle$ ($|2(t)\rangle$). For a given time t , the ground state $|-(t)\rangle$, and the first excited state ($|+(t)\rangle$) of the system are given by [compare with Eqs. (4.222) and (4.226)]

$$|-(t)\rangle = \frac{|1(t)\rangle + |2(t)\rangle}{\sqrt{2}}, \quad (13.99)$$

$$|+(t)\rangle = \frac{|1(t)\rangle - |2(t)\rangle}{\sqrt{2}}. \quad (13.100)$$

In terms of the energy eigenvectors $|-(t)\rangle$ and $|+(t)\rangle$, the initial state $|i\rangle = |1(t)\rangle$ is given by

$$|i\rangle = \frac{|-(t_0)\rangle + |+(t_0)\rangle}{\sqrt{2}}. \quad (13.101)$$

At time $t = 0$, when the two wells collide, the potential becomes $V(x; 0) = -2\alpha\delta(x)$. The single bound state of $V(x; 0)$ has a wavefunction of even symmetry. Thus, in the adiabatic limit (i.e. for small velocity v), the probability that the particle will remain bounded after time $t = 0$ is 0.5 (since $|-(t)\rangle$ has a wavefunction of even symmetry, whereas $|+(t)\rangle$ has a wavefunction of odd symmetry).

2. The exact time evolution operator $u(t)$ is given by [see Eqs. (6.376) and (6.381)]

$$u(t) \doteq U \exp\left(-\frac{i\Omega t}{2}\right) U^{-1}, \quad (13.102)$$

where

$$U = \begin{pmatrix} e^{-\frac{i\omega t}{2}} & 0 \\ 0 & e^{\frac{i\omega t}{2}} \end{pmatrix}, \quad (13.103)$$

$$\Omega = \begin{pmatrix} \Delta & \omega_1 \\ \omega_1 & -\Delta \end{pmatrix}, \quad (13.104)$$

and where $\Delta = \omega_0 - \omega$.

- a) For the case $t = \tau = 2\pi/\omega$ Eq. (13.102) yields

$$u(t) \doteq \exp\left(-\frac{i\Omega t}{2}\right). \quad (13.105)$$

- b) The eigenvalues of Ω are given by $\pm\sqrt{\Delta^2 + \omega_1^2}$, hence $q_{\pm} = \exp(\mp i\lambda)$, where

$$\lambda = \pi \frac{\sqrt{\Delta^2 + \omega_1^2}}{\omega} = \pi \frac{\sqrt{\omega_0^2 + \omega_1^2}}{\omega} - \pi \frac{\omega_0}{\sqrt{\omega_0^2 + \omega_1^2}} + O(\omega). \quad (13.106)$$

- c) For the case $t = \tau = 2\pi/\omega$, the dynamical phases ξ_{\pm} are given by [see Eq. (13.6)]

$$\xi_{\pm} = \mp \pi \frac{\sqrt{\omega_0^2 + \omega_1^2}}{\omega}, \quad (13.107)$$

and the geometrical phases γ_{\pm} are given by [see Eqs. (13.36) and (13.87)]

$$\gamma_{\pm} = \mp \pi \left(1 - \frac{\omega_0}{\sqrt{\omega_0^2 + \omega_1^2}}\right), \quad (13.108)$$

thus to zeroth order in ω the exact result [see Eq. (13.106)] agrees with the adiabatic approximation.

3. The following holds

$$|\tilde{+}\rangle = \exp\left(\frac{i\varphi}{2}\right) |+\rangle, \quad (13.109)$$

$$|\tilde{-}\rangle = \exp\left(\frac{i\varphi}{2}\right) |-\rangle, \quad (13.110)$$

thus the transformed geometrical phase $\tilde{\gamma}_{\pm}(t)$ [see Eq. (13.18)] becomes

$$\gamma_n(t) \rightarrow \tilde{\gamma}_n(t) = \gamma_n(t) - \frac{\varphi(t)}{2} + \frac{\varphi(t_0)}{2}. \quad (13.111)$$

4. The applied magnetic field \mathbf{B} is expressed as $\mathbf{B} = B\hat{\mathbf{u}}$, where both the magnitude B and the unit vector $\hat{\mathbf{u}}$ are time dependent. The Hamiltonian is given by

$$\mathcal{H} = -\gamma B \mathbf{S} \cdot \hat{\mathbf{u}}, \quad (13.112)$$

where γ is the spin gyromagnetic ratio. The common eigenvectors of the spin angular momentum operators \mathbf{S}^2 and $\mathbf{S} \cdot \hat{\mathbf{u}}$ are denoted by $|(s, m)(\hat{\mathbf{u}})\rangle$ [see Eqs. (6.63) and (6.64)], and the following holds

$$\mathcal{H} |(s, m)(\hat{\mathbf{u}})\rangle = E_m(B) |(s, m)(\hat{\mathbf{u}})\rangle, \quad (13.113)$$

where the eigenenergy $E_m(B)$ is given by

$$E_m(B) = -\hbar\gamma B m. \quad (13.114)$$

The geometrical phase γ_m associated with the quantum magnetic number $m \in \{-s, -s+1, \dots, s\}$ is given by [see Eq. (13.32)]

$$\gamma_m = i \int_S \mathbf{d}\mathbf{a} \cdot (\nabla \times \langle (s, m)(\hat{\mathbf{u}}) | \nabla_{\mathbf{B}} | (s, m)(\hat{\mathbf{u}}) \rangle), \quad (13.115)$$

or [see Eq. (15.31)]

$$\gamma_m = i \int_S \mathbf{d}\mathbf{a} \cdot (\nabla_{\mathbf{B}} \langle (s, m)(\hat{\mathbf{u}}) | \rangle \times (\nabla_{\mathbf{B}} | (s, m)(\hat{\mathbf{u}}) \rangle), \quad (13.116)$$

or [see Eq. (2.23)]

$$\gamma_m = i \int_S \mathbf{d}\mathbf{a} \cdot \sum_{m' \neq m} (\langle (s, m)(\hat{\mathbf{u}}) | \nabla_{\mathbf{B}} | (s, m')(\hat{\mathbf{u}}) \rangle \times (\langle (s, m')(\hat{\mathbf{u}}) | \nabla_{\mathbf{B}} | (s, m)(\hat{\mathbf{u}}) \rangle), \quad (13.117)$$

or [see Eqs. (13.14) and (13.114)]

$$\gamma_m = i \int_S \mathbf{d}\mathbf{a} \cdot \sum_{m' \neq m} \frac{\langle (s, m) (\hat{\mathbf{u}}) | (\nabla_{\mathbf{B}} \mathcal{H}) | (s, m') (\hat{\mathbf{u}}) \rangle \times \langle (s, m') (\hat{\mathbf{u}}) | (\nabla_{\mathbf{B}} \mathcal{H}) | (s, m) (\hat{\mathbf{u}}) \rangle}{(E_{m'}(B) - E_m(B))^2}. \quad (13.118)$$

The following holds [see Eq. (13.112)]

$$\nabla_{\mathbf{B}} \mathcal{H} = -\gamma \mathbf{S} = -\gamma \left(\frac{S_+ + S_-}{2}, \frac{S_+ - S_-}{2i}, S_z \right), \quad (13.119)$$

where $S_{\pm} = S_x \pm iS_y$ [see Eqs. (6.32) and (6.36)], and thus [see Eqs. (6.64), (6.65) and (6.66)]

$$\begin{aligned} & \langle (s, m') (\hat{\mathbf{u}}) | (\nabla_{\mathbf{B}} \mathcal{H}) | (s, m) (\hat{\mathbf{u}}) \rangle \\ &= \frac{\sqrt{s(s+1) - m(m+1)} \delta_{m, m'-1} + \sqrt{s(s+1) - m(m-1)} \delta_{m, m'+1}}{2} \hat{\mathbf{x}} \\ &+ \frac{\sqrt{s(s+1) - m(m+1)} \delta_{m, m'-1} - \sqrt{s(s+1) - m(m-1)} \delta_{m, m'+1}}{2i} \hat{\mathbf{y}} \\ &+ m \delta_{m, m'} \hat{\mathbf{z}}, \end{aligned} \quad (13.120)$$

($\hat{\mathbf{z}}$ is taken to be parallel to $\hat{\mathbf{u}}$) hence γ_m becomes [see Eq. (13.114)]

$$\begin{aligned} \gamma_m &= \int_S \mathbf{d}\mathbf{a} \cdot \sum_{m' \neq m} \frac{((s(s+1) - m(m+1)) \delta_{m, m'-1} - (s(s+1) - m(m-1)) \delta_{m, m'+1})}{2B^2 (m' - m)^2} \hat{\mathbf{u}} \\ &= -m \int_S \mathbf{d}\mathbf{a} \cdot \frac{\mathbf{B}}{B^3}, \end{aligned} \quad (13.121)$$

and thus Eq. (13.90) holds [see Eq. (13.36)].

5. The momentary eigenenergies of the system are given by

$$E_n(t) = \frac{\hbar^2 \pi^2 n^2}{2ma_0^2 (1 - \alpha \sin^2(\omega_p t))^2}, \quad (13.122)$$

where $n = 1, 2, \dots$. The corresponding eigenvectors are denoted by $|n(t)\rangle$.

a) In general, the main contribution to interstate transitions come from time periods when the energy gap between neighboring eigenenergies is relatively small. At any given time the smallest energy gap between momentary eigenenergies is the one between the two lowest states $H_{21}(t) = E_2(t) - E_1(t)$. Furthermore, the main contribution to the transition probability is expected to come from the regions near minima points of the energy gap $H_{21}(t)$. Near the minima point at time $t = 0$ the energy gap $H_{21}(t)$ is given by

$$\begin{aligned}
H_{21}(t) &= \frac{3\hbar^2\pi^2}{2ma_0^2(1-\alpha\sin^2(\omega_p t))^2} \\
&= \frac{3\hbar^2\pi^2}{2ma_0^2} \left(1 + 2\alpha(\omega_p t)^2\right) + O(t^3) \\
&= \frac{3\hbar^2\pi^2}{2ma_0^2} \sqrt{1 + 4\alpha(\omega_p t)^2} + O(t^3) .
\end{aligned}
\tag{13.123}$$

The estimated transition probability for the two-dimensional case is given by Eq. (13.66). In view of the fact that all other energy gaps between momentary eigenenergies is at least 5/3 larger than H_{21} , it is expected that this estimate is roughly valid for the present case. The requirement that the transition probability given by Eq. (13.66) is small is taken to be the validity condition for the adiabatic approximation. Comparing the above expression for $H_{21}(t)$ near $t = 0$ with Eq. (13.50) yields the following validity condition

$$2\omega_p\alpha^{1/2} \ll \frac{3\hbar\pi^3}{2ma_0^2} . \tag{13.124}$$

b) In general, the term $\langle n(t') | \dot{n}(t') \rangle$ is pure imaginary [see Eq. (13.9)]. On the other hand, the fact that the wavefunctions of one-dimensional bound states can be chosen to be real (see exercise 7 of chapter 4), implies that $\langle n(t') | \dot{n}(t') \rangle$ is pure real. Thus $\langle n(t') | \dot{n}(t') \rangle = 0$ and therefore all geometrical phases vanish.

6. The Hamiltonian $\mathcal{H}_0 \equiv \lim_{t \rightarrow \pm\infty} \mathcal{H}(t)$ is given by

$$\mathcal{H}_0 = \frac{p^2}{2m} + \frac{m\omega_0^2 x^2}{2} . \tag{13.125}$$

The eigenvectors $|n\rangle$ and eigenenergies $E_{n,0} = \hbar\omega_0(n + 1/2)$ of \mathcal{H}_0 satisfy the following relation

$$\mathcal{H}_0 |n\rangle = E_{n,0} |n\rangle , \tag{13.126}$$

where $n = 0, 1, 2, \dots$. The momentary Hamiltonian $\mathcal{H}(t')$ can be rewritten as

$$\mathcal{H}(t') = \frac{p^2}{2m} + \frac{m\omega_0^2}{2} \left(x + \frac{f(t')}{m\omega_0^2}\right)^2 - \frac{f^2(t')}{2m\omega_0^2} , \tag{13.127}$$

thus $\mathcal{H}(t')$ describes a harmonic oscillator of angular frequency ω_0 having a parabolic potential centered at $-f(t')/m\omega_0^2$, and consequently the momentary eigenvectors $|n(t)\rangle$ of the Hamiltonian $\mathcal{H}(t')$ can be chosen to be coherent states given by [see Eqs. (5.36) and (5.46)]

$$|n(t)\rangle = D(\alpha(t)) |0\rangle , \tag{13.128}$$

where $D(\alpha) = \exp(\alpha a^\dagger - \alpha^* a)$ is the displacement operator, $\alpha(t')$ is given by

$$\alpha(t') = -\frac{f(t')}{2^{1/2} m \omega_0^2 x_0}, \quad (13.129)$$

and

$$x_0 = \sqrt{\frac{\hbar}{m \omega_0}}. \quad (13.130)$$

The following holds

$$\mathcal{H}(t') |n(t')\rangle = E_n(t') |n(t')\rangle, \quad (13.131)$$

where $n = 1, 2, \dots$, the momentary eigenenergies $E_n(t')$ are given by

$$E_n(t') = E_{n,0} - \frac{f^2(t')}{2m\omega_0^2}, \quad (13.132)$$

and $\langle n(t) | m(t) \rangle = \delta_{nm}$. The adiabatic expansion is given by [see Eq. (13.4)]

$$|\psi(t')\rangle = \sum_n a_n(t') e^{i\beta_n(t')} |n(t')\rangle, \quad (13.133)$$

where $\beta_n(t') = \xi_n(t') + \gamma_n(t')$,

$$\xi_n(t') = -\frac{1}{\hbar} \int^t dt'' E_n(t''), \quad (13.134)$$

and

$$\gamma_n(t') = i \int^t dt'' \langle n(t'') | \dot{n}(t'') \rangle. \quad (13.135)$$

To lowest nonvanishing order in the adiabatic approximation the transition probability p_{0n} is given by [see Eqs. (13.14) and (13.46)]

$$p_{n0} = \left| \int_{-\infty}^{\infty} dt' e^{i(\beta_0(t') - \beta_n(t'))} \frac{\langle n(t) | \dot{\mathcal{H}} | 0(t) \rangle}{E_n(t) - E_0(t)} \right|^2, \quad (13.136)$$

where overdot denotes derivative with respect to time. In general the term $\langle n(t') | \dot{n}(t') \rangle$ can be expressed as [see Eq. (5.37)]

$$\begin{aligned} \langle n(t') | \dot{n}(t') \rangle &= \langle 0 | D^\dagger(\alpha(t')) (\dot{\alpha} a^\dagger - \dot{\alpha}^* a) D(\alpha(t')) | 0 \rangle \\ &= \dot{\alpha} \alpha^* - \dot{\alpha}^* \alpha \\ &= 2i |\alpha|^2 \operatorname{Im} \frac{\dot{\alpha}}{\alpha}, \end{aligned} \quad (13.137)$$

thus for the current case, for which $\alpha(t')$ is real, $\langle n(t') | \dot{n}(t') \rangle = 0$, and consequently the geometrical phase $\gamma_n(t)$ vanishes. Furthermore, for the current case $\mathcal{H} = x\dot{f}$, and thus [see Eqs. (5.11), (5.28) and (5.29)]

$$\langle n(t) | \dot{\mathcal{H}} | 0(t) \rangle = 2^{-1/2} x_0 \dot{f} \delta_{n,1} . \quad (13.138)$$

With the help of the above results one finds that

$$p_{n0} = \frac{x_0^2}{2\hbar^2\omega_0^2} \left| \int_{-\infty}^{\infty} dt' e^{i\omega_0 t'} \dot{f} \right|^2 \delta_{n,1} ,$$

or

$$p_{n0} = \mu \delta_{n,1} , \quad (13.139)$$

where

$$\mu = \frac{\lambda^2}{2m\hbar\omega_0} e^{-\frac{1}{2}\omega_0^2\tau^2} . \quad (13.140)$$

Note that the above result is identical to (10.120). Note also that the exact result of this problem is given by [see Eq. (5.373)]

$$p_{n0} = \frac{e^{-\mu} \mu^n}{n!} . \quad (13.141)$$

7. In the limit where $X_0 \gg Y_0$ the coordinate x can be considered as slow, whereas the coordinate y can be considered as fast. For a fixed value of the slow coordinate x , the fast coordinate y is confined by an infinite potential well having width $2Y(x)$, where

$$Y(x) = Y_0 \sqrt{1 - \frac{x^2}{X_0^2}} , \quad (13.142)$$

whose eigenenergies are given by [see Eq. (4.255)]

$$\varepsilon_{n_y}(x) = \frac{\pi^2 \hbar^2 (n_y + 1)^2}{8mY^2(x)} = \frac{m\omega_{n_y}^2}{2} \frac{X_0^4}{X_0^2 - x^2} , \quad (13.143)$$

where $n_y \geq 0$ is an integer, and where the angular frequency ω_{n_y} is given by

$$\omega_{n_y} = \frac{\pi \hbar (n_y + 1)}{2mX_0Y_0} . \quad (13.144)$$

In the adiabatic approximation the effective Hamiltonian $\mathcal{H}_{A,m}$ for the slow coordinate x for the case where the fast subsystem is in the n_y 'th state is given by [see Eq. (13.84)]

$$\mathcal{H}_{A,n_y} = \frac{p_x^2}{2m} + \varepsilon_{n_y}(x) . \quad (13.145)$$

The following holds

$$\frac{X_0^4}{X_0^2 - x^2} = X_0^2 + x^2 + \frac{x^4}{X_0^2} + O(x^6) , \quad (13.146)$$

thus when terms higher than second order in x are disregarded the energy eigenvalues are given by [see Eq. (5.19)]

$$\begin{aligned} E_{n_y, n_x} &= \frac{m\omega_{n_y}^2 X_0^2}{2} + \hbar\omega_{n_y} \left(n_x + \frac{1}{2} \right) \\ &= \frac{\pi^2 \hbar^2 (n_y + 1)^2}{8mY_0^2} + \frac{\pi \hbar^2 (n_y + 1) (n_x + \frac{1}{2})}{2mX_0 Y_0} , \end{aligned} \quad (13.147)$$

where $n_x \geq 0$ is an integer. For small values of n_x and n_y the approximation made by disregarding terms higher than second order in x is valid provided that [see Eq. (5.126)]

$$\sqrt{\frac{\hbar}{m\omega_{n_y=0}}} \ll X_0 , \quad (13.148)$$

or $X_0 \gg (2/\pi) Y_0$. This condition is assumed to hold.

8. Note that the real part $T'_{n,\mu\nu}$ of $T_{n,\mu\nu}$ is symmetric and the imaginary $T''_{n,\mu\nu}$ part is antisymmetric

$$\begin{aligned} T'_{n,\mu\nu} &= T'_{n,\nu\mu} \\ &= \frac{\langle \partial_\mu n | (1 - |n\rangle \langle n|) | \partial_\nu n \rangle + \langle \partial_\nu n | (1 - |n\rangle \langle n|) | \partial_\mu n \rangle}{2} , \end{aligned} \quad (13.149)$$

$$\begin{aligned} T''_{n,\mu\nu} &= -T''_{n,\nu\mu} \\ &= \frac{\langle \partial_\mu n | (1 - |n\rangle \langle n|) | \partial_\nu n \rangle - \langle \partial_\nu n | (1 - |n\rangle \langle n|) | \partial_\mu n \rangle}{2i} . \end{aligned} \quad (13.150)$$

- a) The following holds [see Eq. (13.96)]

$$\begin{aligned} &\sum_{\mu\nu} T_{n,\mu\nu} ds_\mu ds_\nu \\ &= \left(\sum_\mu \langle \partial_\mu n | ds_\mu \right) (1 - |n\rangle \langle n|) \left(\sum_\nu | \partial_\nu n \rangle ds_\nu \right) \\ &= (\langle n(\mathbf{s} + d\mathbf{s}) | - \langle n(\mathbf{s}) |) (1 - |n(\mathbf{s})\rangle \langle n(\mathbf{s})|) (|n(\mathbf{s} + d\mathbf{s})\rangle - |n(\mathbf{s})\rangle) \\ &\quad + O(|d\mathbf{s}|^3) , \end{aligned} \quad (13.151)$$

and

$$\langle n(\mathbf{s}) | (1 - |n(\mathbf{s})\rangle \langle n(\mathbf{s})|) = (1 - |n(\mathbf{s})\rangle \langle n(\mathbf{s})|) |n(\mathbf{s})\rangle = 0, \quad (13.152)$$

thus (recall that $T''_{n,\mu\nu}$ is antisymmetric)

$$\sum_{\mu\nu} T'_{n,\mu\nu} ds_\mu ds_\nu = 1 - |\langle n(\mathbf{s}) | n(\mathbf{s} + d\mathbf{s}) \rangle|^2. \quad (13.153)$$

b) The tensor $T_{n,ij}$ is transformed according to

$$\begin{aligned} T_{n,\mu\nu} &\rightarrow \tilde{T}_{n,\mu\nu} \\ &= (\langle \partial_\mu n | + i \langle \partial_\mu A |) \langle n | (1 - |n\rangle \langle n|) (|\partial_\nu n\rangle - i \langle \partial_\nu A | n \rangle), \end{aligned} \quad (13.154)$$

and thus [see Eq. (13.152)]

$$\tilde{T}_{n,\mu\nu} = T_{n,\mu\nu}. \quad (13.155)$$

c) With the help of Eqs. (13.24) and (13.25) one finds that [see Eq. (13.96)]

$$T_{+,\theta\theta} = T_{-,\theta\theta} = \frac{1}{4}, \quad (13.156)$$

$$T_{+,\theta\varphi} = -T_{-,\theta\varphi} = \frac{i \sin \theta}{4}, \quad (13.157)$$

$$T_{+,\varphi\theta} = T_{-,\varphi\theta}(\mathbf{s}) = -\frac{i \sin \theta}{4}, \quad (13.158)$$

$$T_{+,\varphi\varphi} = T_{-,\varphi\varphi} = \frac{\sin^2 \theta}{4}, \quad (13.159)$$

and thus [see Eq. (13.98)]

$$1 - |\langle \pm(\mathbf{s}) | \pm(\mathbf{s} + d\mathbf{s}) \rangle|^2 = \frac{(d\theta)^2 + \sin^2 \theta (d\varphi)^2}{4} + O(|d\mathbf{s}|^3). \quad (13.160)$$

14. The Quantized Electromagnetic Field

This chapter discusses the quantization of electromagnetic (EM) field for the relatively simple case of a free space cavity.

14.1 Classical Electromagnetic Cavity

Consider an empty volume surrounded by conductive walls having infinite conductivity. The Maxwell's equations (in Gaussian units) are given by

$$\nabla \times \mathbf{B} = \frac{1}{c} \frac{\partial \mathbf{E}}{\partial t} , \quad (14.1)$$

$$\nabla \times \mathbf{E} = -\frac{1}{c} \frac{\partial \mathbf{B}}{\partial t} , \quad (14.2)$$

$$\nabla \cdot \mathbf{E} = 0 , \quad (14.3)$$

$$\nabla \cdot \mathbf{B} = 0 , \quad (14.4)$$

where $c = 2.99 \times 10^8 \text{ m s}^{-1}$ is the speed of light in vacuum. In the Coulomb gauge the vector potential \mathbf{A} is chosen such that

$$\nabla \cdot \mathbf{A} = 0 , \quad (14.5)$$

and the scalar potential φ vanishes in the absence of sources (charge and current). In this gauge both electric and magnetic fields \mathbf{E} and \mathbf{B} can be expressed in terms of \mathbf{A} only as [see Eqs. (1.41) and (1.42)]

$$\mathbf{E} = -\frac{1}{c} \frac{\partial \mathbf{A}}{\partial t} , \quad (14.6)$$

and

$$\mathbf{B} = \nabla \times \mathbf{A} . \quad (14.7)$$

Exercise 14.1.1. Show that

$$\nabla^2 \mathbf{A} = \frac{1}{c^2} \frac{\partial^2 \mathbf{A}}{\partial t^2} . \quad (14.8)$$

Solution 14.1.1. The gauge condition (14.5) and Eqs. (14.6) and (14.7) guarantee that Maxwell's equations (14.2), (14.3), and (14.4) are satisfied

$$\nabla \times \mathbf{E} = -\frac{1}{c} \frac{\partial (\nabla \times \mathbf{A})}{\partial t} = -\frac{1}{c} \frac{\partial \mathbf{B}}{\partial t}, \quad (14.9)$$

$$\nabla \cdot \mathbf{E} = -\frac{1}{c} \frac{\partial (\nabla \cdot \mathbf{A})}{\partial t} = 0, \quad (14.10)$$

$$\nabla \cdot \mathbf{B} = \nabla \cdot (\nabla \times \mathbf{A}) = 0, \quad (14.11)$$

where in the last equation the general vector identity $\nabla \cdot (\nabla \times \mathbf{A}) = 0$ has been employed. Substituting Eqs. (14.6) and (14.7) into the only remaining nontrivial equation, namely into Eq. (14.1), leads to

$$\nabla \times (\nabla \times \mathbf{A}) = -\frac{1}{c^2} \frac{\partial^2 \mathbf{A}}{\partial t^2}. \quad (14.12)$$

Using the vector identity

$$\nabla \times (\nabla \times \mathbf{A}) = \nabla (\nabla \cdot \mathbf{A}) - \nabla^2 \mathbf{A}, \quad (14.13)$$

and the gauge condition (14.5) one finds that

$$\nabla^2 \mathbf{A} = \frac{1}{c^2} \frac{\partial^2 \mathbf{A}}{\partial t^2}. \quad (14.14)$$

Exercise 14.1.2. Consider a solution having the form

$$\mathbf{A} = q(t) \mathbf{u}(\mathbf{r}), \quad (14.15)$$

where $q(t)$ is independent on position \mathbf{r} and $\mathbf{u}(\mathbf{r})$ is independent on time t . Show that $q(t)$ and $\mathbf{u}(\mathbf{r})$ must satisfy

$$\nabla^2 \mathbf{u} + \kappa^2 \mathbf{u} = 0, \quad (14.16)$$

and

$$\frac{d^2 q}{dt^2} + \omega_\kappa^2 q = 0, \quad (14.17)$$

where κ is a constant and where

$$\omega_\kappa = c\kappa. \quad (14.18)$$

Solution 14.1.2. The gauge condition (14.5) leads to

$$\nabla \cdot \mathbf{u} = 0. \quad (14.19)$$

From Eq. (14.8) one finds that

$$q \nabla^2 \mathbf{u} = \frac{1}{c^2} \mathbf{u} \frac{d^2 q}{dt^2}. \quad (14.20)$$

Multiplying by an arbitrary unit vector $\hat{\mathbf{n}}$ leads to

$$\frac{(\nabla^2 \mathbf{u}) \cdot \hat{\mathbf{n}}}{\mathbf{u} \cdot \hat{\mathbf{n}}} = \frac{1}{c^2} \frac{d^2 q}{dt^2}. \quad (14.21)$$

The left hand side of Eq. (14.21) is a function of \mathbf{r} only while the right hand side is a function of t only. Therefore, both should equal a constant, which is denoted as $-\kappa^2$, thus

$$\nabla^2 \mathbf{u} + \kappa^2 \mathbf{u} = 0, \quad (14.22)$$

and

$$\frac{d^2 q}{dt^2} + \omega_\kappa^2 q = 0, \quad (14.23)$$

where

$$\omega_\kappa = c\kappa. \quad (14.24)$$

Exercise 14.1.3. Show that the general solution can be expanded as

$$\mathbf{A} = \sum_n q_n(t) \mathbf{u}_n(\mathbf{r}). \quad (14.25)$$

where the set $\{\mathbf{u}_n\}$ forms a complete orthonormal basis spanning the vector space of all solutions of Eq. (14.16) satisfying the proper boundary conditions on the conductive walls having infinite conductivity.

Solution 14.1.3. Equation (14.16) should be solved with the boundary conditions of a perfectly conductive surface. Namely, on the surface S enclosing the cavity we have $\mathbf{B} \cdot \hat{\mathbf{s}} = 0$ and $\mathbf{E} \times \hat{\mathbf{s}} = 0$, where $\hat{\mathbf{s}}$ is a unit vector normal to the surface. To satisfy the boundary condition for \mathbf{E} we require that \mathbf{u} be normal to the surface, namely, $\mathbf{u} = \hat{\mathbf{s}}(\mathbf{u} \cdot \hat{\mathbf{s}})$ on S . This condition guarantees also that the boundary condition for \mathbf{B} is satisfied. To see this we calculate the integral of the normal component of \mathbf{B} over some arbitrary portion S' of S . Using Eq. (14.7) and Stoke's' theorem one finds that

$$\begin{aligned} \int_{S'} (\mathbf{B} \cdot \hat{\mathbf{s}}) dS &= q \int_{S'} [(\nabla \times \mathbf{u}) \cdot \hat{\mathbf{s}}] dS \\ &= q \oint_C \mathbf{u} \cdot d\mathbf{l}, \end{aligned} \quad (14.26)$$

where the close curve C encloses the surface S' . Thus, since \mathbf{u} is normal to the surface, one finds that the integral along the close curve C vanishes, and therefore

$$\int_{S'} (\mathbf{B} \cdot \hat{\mathbf{s}}) dS = 0 . \quad (14.27)$$

Since S' is arbitrary we conclude that $\mathbf{B} \cdot \hat{\mathbf{s}} = 0$ on S . Each solution of Eq. (14.16) that satisfies the boundary conditions is called an eigen mode. As can be seen from Eq. (14.23), the dynamics of a mode amplitude q is the same as the dynamics of a harmonic oscillator having angular frequency $\omega_\kappa = c\kappa$. Inner product between different solutions of Eq. (14.16) that satisfy the boundary conditions can be defined as

$$\langle \mathbf{u}_1, \mathbf{u}_2 \rangle \equiv \int_V (\mathbf{u}_1 \cdot \mathbf{u}_2) dV , \quad (14.28)$$

where the integral is taken over the volume of the cavity. Using Eq. (14.16) one finds that

$$(\kappa_2^2 - \kappa_1^2) \int_V (\mathbf{u}_1 \cdot \mathbf{u}_2) dV = \int_V (\mathbf{u}_1 \cdot \nabla^2 \mathbf{u}_2 - \mathbf{u}_2 \cdot \nabla^2 \mathbf{u}_1) dV . \quad (14.29)$$

With the help of the vector identities

$$\nabla \cdot (a\mathbf{A}) = a\nabla \cdot \mathbf{A} + \mathbf{A} \cdot \nabla a , \quad (14.30)$$

$$\nabla (\nabla \cdot \mathbf{A}) = \nabla^2 \mathbf{A} + \nabla \times (\nabla \times \mathbf{A}) , \quad (14.31)$$

$$\nabla \cdot (\mathbf{A} \times \mathbf{B}) = (\nabla \times \mathbf{A}) \cdot \mathbf{B} - (\nabla \times \mathbf{B}) \cdot \mathbf{A} , \quad (14.32)$$

one finds that $\mathbf{u}_1 \cdot \nabla^2 \mathbf{u}_2 - \mathbf{u}_2 \cdot \nabla^2 \mathbf{u}_1 = \nabla \cdot \mathbf{V}$, where the vector \mathbf{V} is given by

$$\mathbf{V} = \mathbf{u}_1 (\nabla \cdot \mathbf{u}_2) - \mathbf{u}_2 (\nabla \cdot \mathbf{u}_1) - \mathbf{u}_2 \times \nabla \times \mathbf{u}_1 + \mathbf{u}_1 \times \nabla \times \mathbf{u}_2 , \quad (14.33)$$

The divergence theorem yields

$$(\kappa_2^2 - \kappa_1^2) \int_V (\mathbf{u}_1 \cdot \mathbf{u}_2) dV = \int_S (\mathbf{V} \cdot \hat{\mathbf{s}}) dS . \quad (14.34)$$

The surface integral vanishes [see Eq. (14.19), and recall that $\mathbf{u} = \hat{\mathbf{s}} (\mathbf{u} \cdot \hat{\mathbf{s}})$ on S], thus solutions with different κ^2 are orthogonal to each other. Let $\{\mathbf{u}_n\}$ be a complete orthonormal basis spanning the vector space of all solutions of Eq. (14.16) satisfying the boundary conditions. For any two vectors in this basis the orthonormality condition is

$$\langle \mathbf{u}_n, \mathbf{u}_m \rangle = \int_V (\mathbf{u}_n \cdot \mathbf{u}_m) dV = \delta_{n,m} . \quad (14.35)$$

Using such a basis we can expand the general solution as

$$\mathbf{A} = \sum_n q_n(t) \mathbf{u}_n(\mathbf{r}) . \quad (14.36)$$

Exercise 14.1.4. Show that the total electric energy in the cavity is given by

$$U_E = \frac{1}{8\pi c^2} \sum_n \dot{q}_n^2, \quad (14.37)$$

and the total magnetic energy is given by

$$U_B = \frac{1}{8\pi} \sum_n \kappa_n^2 q_n^2. \quad (14.38)$$

Solution 14.1.4. Using Eqs. (14.6),(14.7) and (14.25) one finds that the fields are given by

$$\mathbf{E} = -\frac{1}{c} \sum_n \dot{q}_n \mathbf{u}_n, \quad (14.39)$$

and

$$\mathbf{B} = \sum_n q_n \nabla \times \mathbf{u}_n. \quad (14.40)$$

The total energy of the field is given by $U_E + U_B$, where U_E (U_B) is the energy associated with the electric (magnetic) field, namely,

$$U_E = \frac{1}{8\pi} \int_V \mathbf{E}^2 dV, \quad (14.41)$$

and

$$U_B = \frac{1}{8\pi} \int_V \mathbf{B}^2 dV. \quad (14.42)$$

Using Eqs. (14.39) and (14.35) one finds that

$$U_E = \frac{1}{8\pi c^2} \sum_n \dot{q}_n^2, \quad (14.43)$$

and using Eq. (14.40) one finds that

$$U_B = \frac{1}{8\pi} \sum_{n,m} q_n q_m \int_V (\nabla \times \mathbf{u}_n) \cdot (\nabla \times \mathbf{u}_m) dV. \quad (14.44)$$

The last integral can be calculated by using the vector identity

$$\nabla \cdot (\mathbf{F}_1 \times \mathbf{F}_2) = (\nabla \times \mathbf{F}_1) \cdot \mathbf{F}_2 - \mathbf{F}_1 \cdot (\nabla \times \mathbf{F}_2), \quad (14.45)$$

applied to $\mathbf{u}_n \times (\nabla \times \mathbf{u}_m)$, thus

$$(\nabla \times \mathbf{u}_n) \cdot (\nabla \times \mathbf{u}_m) = \nabla \cdot (\mathbf{u}_n \times (\nabla \times \mathbf{u}_m)) + \mathbf{u}_n \cdot [\nabla \times (\nabla \times \mathbf{u}_m)] . \quad (14.46)$$

Using the divergence theorem and the fact that \mathbf{u}_n and $(\nabla \times \mathbf{u}_m)$ are orthogonal to each other on S one finds that the volume integral of the first term vanishes. To calculate the integral of the second term it is convenient to use the identity

$$\nabla \times (\nabla \times \mathbf{u}_m) = \nabla (\nabla \cdot \mathbf{u}_m) - \nabla^2 \mathbf{u}_m . \quad (14.47)$$

This together with Eqs. (14.19), (14.16), and (14.35) lead to

$$U_B = \frac{1}{8\pi} \sum_n \kappa_n^2 q_n^2 . \quad (14.48)$$

The Lagrangian of the system is given by [see Eq. (1.16)]

$$\mathcal{L} = U_E - U_B = \frac{1}{4\pi c^2} \sum_n \left(\frac{\dot{q}_n^2}{2} - \frac{\omega_n^2 q_n^2}{2} \right) , \quad (14.49)$$

where the symbol overdot is used for derivative with respect to time, and where $\omega_n = c\kappa_n$. The Euler-Lagrange equations (1.8), given by

$$\frac{d}{dt} \left(\frac{\partial \mathcal{L}}{\partial \dot{q}_n} \right) - \frac{\partial \mathcal{L}}{\partial q_n} = 0 , \quad (14.50)$$

lead to Eq. (14.23).

The variable canonically conjugate to q_n is [see Eq. (1.20)]

$$p_n = \frac{\partial \mathcal{L}}{\partial \dot{q}_n} = \frac{1}{4\pi c^2} \dot{q}_n . \quad (14.51)$$

The classical Hamiltonian \mathcal{H}_F of the field is given by [see Eq. (1.22)]

$$\mathcal{H}_F = \sum_n p_n \dot{q}_n - \mathcal{L} = \sum_n \left(\frac{4\pi c^2 p_n^2}{2} + \frac{1}{4\pi c^2} \frac{\omega_n^2 q_n^2}{2} \right) . \quad (14.52)$$

The Hamilton-Jacobi equations of motion, which are given by

$$\dot{q}_n = \frac{\partial \mathcal{H}_F}{\partial p_n} = 4\pi c^2 p_n , \quad (14.53)$$

$$\dot{p}_n = -\frac{\partial \mathcal{H}_F}{\partial q_n} = -\frac{\omega_n^2}{4\pi c^2} q_n , \quad (14.54)$$

lead also to Eq. (14.23). Note that, as expected, the following holds

$$\mathcal{H}_F = U_E + U_B , \quad (14.55)$$

namely the Hamiltonian expresses the total energy of the system.

14.2 Quantum Electromagnetic Cavity

The coordinates q_n and their canonically conjugate variables p_n are regarded as Hermitian operators satisfying the following commutation relations [see Eqs. (3.5) and (4.41)]

$$[q_n, p_m] = i\hbar\delta_{n,m} , \quad (14.56)$$

and

$$[q_n, q_m] = [p_n, p_m] = 0 . \quad (14.57)$$

In general, the Heisenberg equation of motion (4.37) of an operator $A^{(H)}$ is given by

$$\frac{dA^{(H)}}{dt} = \frac{1}{i\hbar} [A^{(H)}, \mathcal{H}_F^{(H)}] + \left(\frac{\partial A}{\partial t} \right)^{(H)} . \quad (14.58)$$

Thus, with the help of Eq. (14.52) one finds that

$$\dot{q}_n = 4\pi c^2 p_n , \quad (14.59)$$

and

$$\dot{p}_n = -\frac{\omega_n^2}{4\pi c^2} q_n . \quad (14.60)$$

It is useful to introduce the annihilation and creation operators

$$a_n = e^{i\omega_n t} \sqrt{\frac{\omega_n}{8\pi c^2 \hbar}} \left(q_n + \frac{4\pi i c^2 p_n}{\omega_n} \right) , \quad (14.61)$$

$$a_n^\dagger = e^{-i\omega_n t} \sqrt{\frac{\omega_n}{8\pi c^2 \hbar}} \left(q_n - \frac{4\pi i c^2 p_n}{\omega_n} \right) . \quad (14.62)$$

The phase factor $e^{i\omega_n t}$ in the definition of a_n is added in order to make it time independent. The inverse transformation is given by

$$q_n = \sqrt{\frac{2\pi c^2 \hbar}{\omega_n}} (e^{-i\omega_n t} a_n + e^{i\omega_n t} a_n^\dagger) , \quad (14.63)$$

$$p_n = i\sqrt{\frac{\hbar \omega_n}{8\pi c^2}} (-e^{-i\omega_n t} a_n + e^{i\omega_n t} a_n^\dagger) . \quad (14.64)$$

The commutation relations for these operators are derived directly from Eqs. (14.56) and (14.57)

$$[a_n, a_m^\dagger] = \delta_{n,m} , \quad (14.65)$$

$$[a_n, a_m] = [a_n^\dagger, a_m^\dagger] = 0 . \quad (14.66)$$

The Hamiltonian (14.52) can be expressed using Eqs. (14.63) and (14.64) as

$$\mathcal{H}_F = \sum_n \hbar\omega_n \left(a_n^\dagger a_n + \frac{1}{2} \right). \quad (14.67)$$

The eigenstates are the photon-number states $|s_1, s_2, \dots, s_n, \dots\rangle$, which satisfy [see chapter 5]

$$\mathcal{H}_F |s_1, s_2, \dots, s_n, \dots\rangle = \sum_n \hbar\omega_n \left(s_n + \frac{1}{2} \right) |s_1, s_2, \dots, s_n, \dots\rangle. \quad (14.68)$$

The following holds [see Eqs. (5.28) and (5.29)]

$$a_n |s_1, s_2, \dots, s_n, \dots\rangle = \sqrt{s_n} |s_1, s_2, \dots, s_n - 1, \dots\rangle, \quad (14.69)$$

$$a_n^\dagger |s_1, s_2, \dots, s_n, \dots\rangle = \sqrt{s_n + 1} |s_1, s_2, \dots, s_n + 1, \dots\rangle. \quad (14.70)$$

The non-negative integer s_n is the number of photons occupying mode n . The vector potential \mathbf{A} (14.25) becomes

$$\mathbf{A}(\mathbf{r}, t) = \sum_n \sqrt{\frac{2\pi c^2 \hbar}{\omega_n}} \left(e^{-i\omega_n t} a_n + e^{i\omega_n t} a_n^\dagger \right) \mathbf{u}_n(\mathbf{r}). \quad (14.71)$$

14.3 Periodic Boundary Conditions

Consider the case where the EM field is confined to a finite volume V , which for simplicity is taken to have a cube shape with edge $L = V^{-1/3}$. The eigen modes and eigen frequencies of the EM field are found in exercise 1 of this chapter for the case where the walls of the cavity are assumed to have infinite conductance [see Eq. (14.150)]. It is however more convenient to assume instead periodic boundary conditions, since the spatial dependence of the resulting eigen modes [denoted by $\mathbf{u}_n(\mathbf{r})$], can be expressed in terms of exponential functions, rather than trigonometric functions [see Eqs. (14.143), (14.144) and (14.145)]. For this case Eq. (14.67) becomes

$$\mathcal{H}_F = \sum_{\mathbf{k}, \lambda} \hbar\omega_{\mathbf{k}} \left(a_{\mathbf{k}, \lambda}^\dagger a_{\mathbf{k}, \lambda} + \frac{1}{2} \right), \quad (14.72)$$

and Eq. (14.71) becomes

$$\mathbf{A}(\mathbf{r}, t) = \sum_{\mathbf{k}, \lambda} \sqrt{\frac{2\pi c^2 \hbar}{\omega_{\mathbf{k}} V}} \left(\hat{\mathbf{e}}_{\mathbf{k}, \lambda} e^{i(\mathbf{k} \cdot \mathbf{r} - \omega_{\mathbf{k}} t)} a_{\mathbf{k}, \lambda} + \hat{\mathbf{e}}_{\mathbf{k}, \lambda}^* e^{-i(\mathbf{k} \cdot \mathbf{r} - \omega_{\mathbf{k}} t)} a_{\mathbf{k}, \lambda}^\dagger \right), \quad (14.73)$$

where the eigen frequencies are given by $\omega_{\mathbf{k}} = c|\mathbf{k}|$. In the limit of large volume the discrete sum over wave vectors \mathbf{k} can be replaced by an integral

$$\sum_{\mathbf{k}} \rightarrow \frac{V}{(2\pi)^3} \int_{-\infty}^{\infty} dk_x \int_{-\infty}^{\infty} dk_y \int_{-\infty}^{\infty} dk_z, \quad (14.74)$$

and the commutation relations between field operators become

$$[a_{\mathbf{k},\lambda}, a_{\mathbf{k}',\lambda}] = [a_{\mathbf{k},\lambda}^\dagger, a_{\mathbf{k}',\lambda}^\dagger] = 0, \quad (14.75)$$

$$[a_{\mathbf{k},\lambda}, a_{\mathbf{k}',\lambda'}^\dagger] = \delta_{\lambda,\lambda'} \delta(\mathbf{k} - \mathbf{k}'). \quad (14.76)$$

The sum over λ contains two terms corresponding to two polarization vectors $\hat{\mathbf{e}}_{\mathbf{k},\lambda}$, which are normalized to unity and mutually orthogonal, i.e. $\hat{\mathbf{e}}_{\mathbf{k},\lambda}^* \cdot \hat{\mathbf{e}}_{\mathbf{k},\lambda'} = \delta_{\lambda,\lambda'}$. Furthermore, the Coulomb gauge condition requires that $\hat{\mathbf{e}}_{\mathbf{k},\lambda} \cdot \mathbf{k} = \hat{\mathbf{e}}_{\mathbf{k},\lambda}^* \cdot \mathbf{k} = 0$, i.e. the polarization vectors are required to be orthogonal to the wave vector \mathbf{k} . Colinear polarization can be represented by two mutually orthogonal real vectors $\hat{\mathbf{e}}_{\mathbf{k},1}$ and $\hat{\mathbf{e}}_{\mathbf{k},2}$, which satisfy $\hat{\mathbf{e}}_{\mathbf{k},1} \times \hat{\mathbf{e}}_{\mathbf{k},2} = \mathbf{k}/|\mathbf{k}|$. For the case of circular polarization the polarization vectors can be chosen to be given by

$$\hat{\mathbf{e}}_{\mathbf{k},+} = -\frac{1}{\sqrt{2}} (\hat{\mathbf{e}}_{\mathbf{k},1} + i\hat{\mathbf{e}}_{\mathbf{k},2}), \quad (14.77)$$

$$\hat{\mathbf{e}}_{\mathbf{k},-} = \frac{1}{\sqrt{2}} (\hat{\mathbf{e}}_{\mathbf{k},1} - i\hat{\mathbf{e}}_{\mathbf{k},2}). \quad (14.78)$$

For this case of circular polarization the following holds

$$\hat{\mathbf{e}}_{\mathbf{k},\lambda}^* \cdot \hat{\mathbf{e}}_{\mathbf{k},\lambda'} = \delta_{\lambda,\lambda'}, \quad (14.79)$$

$$\hat{\mathbf{e}}_{\mathbf{k},\lambda}^* \times \hat{\mathbf{e}}_{\mathbf{k},\lambda'} = i\lambda \frac{\mathbf{k}}{|\mathbf{k}|} \delta_{\lambda,\lambda'}, \quad (14.80)$$

where $\lambda = 1$ for right-handed circular polarization and $\lambda = -1$ for left-handed circular polarization.

For a general unit vector $\hat{\mathbf{n}}$, which in spherical coordinates can be expressed as

$$\hat{\mathbf{n}} = (\cos \varphi \sin \theta, \sin \varphi \sin \theta, \cos \theta), \quad (14.81)$$

the polarization vectors $\hat{\mathbf{e}}_{\mathbf{k},(\pm;\hat{\mathbf{n}})}$ are defined by [compare with Eqs. (6.301) and (6.302)]

$$\hat{\mathbf{e}}_{\mathbf{k},(+;\hat{\mathbf{n}})} = \cos \frac{\theta}{2} e^{-\frac{i\varphi}{2}} \hat{\mathbf{e}}_{\mathbf{k},+} + \sin \frac{\theta}{2} e^{\frac{i\varphi}{2}} \hat{\mathbf{e}}_{\mathbf{k},-}, \quad (14.82)$$

$$\hat{\mathbf{e}}_{\mathbf{k},(-;\hat{\mathbf{n}})} = -\sin \frac{\theta}{2} e^{-\frac{i\varphi}{2}} \hat{\mathbf{e}}_{\mathbf{k},+} + \cos \frac{\theta}{2} e^{\frac{i\varphi}{2}} \hat{\mathbf{e}}_{\mathbf{k},-}, \quad (14.83)$$

and the following holds

$$\hat{\mathbf{e}}_{\mathbf{k},(\lambda;\hat{\mathbf{n}})}^* \cdot \hat{\mathbf{e}}_{\mathbf{k},(\lambda';\hat{\mathbf{n}})} = \delta_{\lambda,\lambda'}, \quad (14.84)$$

$$\hat{\mathbf{e}}_{\mathbf{k},(\lambda;\hat{\mathbf{n}})}^* \times \hat{\mathbf{e}}_{\mathbf{k},(\lambda';\hat{\mathbf{n}})} = i \frac{\mathbf{k}}{|\mathbf{k}|} [\lambda \cos \theta \delta_{\lambda,\lambda'} - \sin \theta (1 - \delta_{\lambda,\lambda'})]. \quad (14.85)$$

The linear momentum \mathbf{P}_F and angular momentum \mathbf{M}_F of the field are taken to be given by

$$\mathbf{P}_F = \int dV \frac{\mathbf{E} \times \mathbf{B} - \mathbf{B} \times \mathbf{E}}{8\pi c}, \quad (14.86)$$

and

$$\mathbf{M}_F = - \int dV \frac{\mathbf{A} \times \mathbf{E} - \mathbf{E} \times \mathbf{A}}{8\pi c}. \quad (14.87)$$

With the help of Eqs. (14.6), (14.7) and (14.73), the following general vector identity

$$\mathbf{V}_1 \times (\mathbf{V}_2 \times \mathbf{V}_3) = (\mathbf{V}_1 \cdot \mathbf{V}_3) \mathbf{V}_2 - (\mathbf{V}_1 \cdot \mathbf{V}_2) \mathbf{V}_3, \quad (14.88)$$

and the orthonormality condition (14.35) one finds that

$$\mathbf{P}_F = \hbar \sum_{\mathbf{k}', \lambda'} \mathbf{k}' a_{\mathbf{k}', \lambda'}^\dagger a_{\mathbf{k}', \lambda'}, \quad (14.89)$$

and

$$\mathbf{M}_F = -i\hbar \sum_{\mathbf{k}', \lambda'} (\hat{\mathbf{e}}_{\mathbf{k}', \lambda'}^* \times \hat{\mathbf{e}}_{\mathbf{k}', \lambda'}) a_{\mathbf{k}', \lambda'}^\dagger a_{\mathbf{k}', \lambda'}. \quad (14.90)$$

Note that for colinear polarization $\hat{\mathbf{e}}_{\mathbf{k}', \lambda'}^* \times \hat{\mathbf{e}}_{\mathbf{k}', \lambda'} = 0$, whereas for circular polarization $\hat{\mathbf{e}}_{\mathbf{k}', \lambda'}^* \times \hat{\mathbf{e}}_{\mathbf{k}', \lambda'} = i\lambda' \mathbf{k}' / |\mathbf{k}'|$, where $\lambda' \in \{+, -\}$ [see Eq. (14.85)].

14.4 The Poincaré sphere

The state of polarization (SOP) can be described as a point in the Poincaré unit sphere (see Fig. 14.1). Notation for some specific states of polarization are given in table 14.1 below.

The vector representation of a SOP is called a Jones vector, and a polarization transformation is represented by a 2×2 Jones matrix J . For a general unit vector $\hat{\mathbf{n}} = (\cos \varphi \sin \theta, \sin \varphi \sin \theta, \cos \theta)$, the SOP $|\pm(\hat{\mathbf{n}})\rangle$ is the eigenvector of the matrix $\boldsymbol{\sigma} \cdot \hat{\mathbf{n}}$ with eigenvalue ± 1 , where

$$\boldsymbol{\sigma} \cdot \hat{\mathbf{n}} = \begin{pmatrix} \cos \theta & \sin \theta e^{-i\varphi} \\ \sin \theta e^{i\varphi} & -\cos \theta \end{pmatrix}, \quad (14.91)$$

and where $\boldsymbol{\sigma}$ is the Pauli spin matrix vector [see Eq. (6.137)], and thus in the basis $\{|V\rangle, |H\rangle\}$ one has [see Eqs. (6.301) and (6.302)]

$$|+(\hat{\mathbf{n}})\rangle = \cos \frac{\theta}{2} |V\rangle + \sin \frac{\theta}{2} e^{i\varphi} |H\rangle \doteq \begin{pmatrix} \cos \frac{\theta}{2} \\ \sin \frac{\theta}{2} e^{i\varphi} \end{pmatrix}, \quad (14.92)$$

$$|-(\hat{\mathbf{n}})\rangle = \sin \frac{\theta}{2} |V\rangle - \cos \frac{\theta}{2} e^{i\varphi} |H\rangle \doteq \begin{pmatrix} \sin \frac{\theta}{2} \\ -\cos \frac{\theta}{2} e^{i\varphi} \end{pmatrix}. \quad (14.93)$$

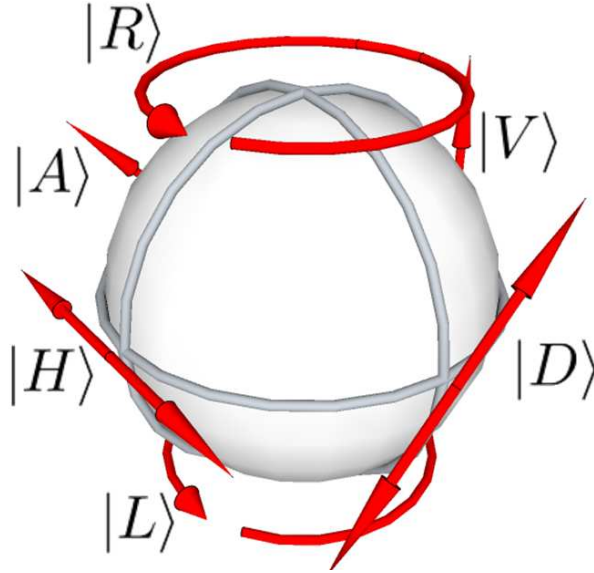

Fig. 14.1. The Poincaré sphere.

SOP	ket	$\hat{\mathbf{n}}$
colinear diagonal	$ D\rangle = \frac{ H\rangle + V\rangle}{\sqrt{2}}$	$\hat{\mathbf{x}}$
colinear anti-diagonal	$ A\rangle = \frac{ H\rangle - V\rangle}{\sqrt{2}}$	$-\hat{\mathbf{x}}$
circular left-hand	$ L\rangle = \frac{ H\rangle + i V\rangle}{\sqrt{2}}$	$\hat{\mathbf{y}}$
circular right-hand	$ R\rangle = \frac{ H\rangle - i V\rangle}{\sqrt{2}}$	$-\hat{\mathbf{y}}$
colinear vertical	$ V\rangle$	$\hat{\mathbf{z}}$
colinear horizontal	$ H\rangle$	$-\hat{\mathbf{z}}$

Table 14.1. States of polarization (SOP).

The operator $B(\hat{\mathbf{n}}, \phi)$, which represents a rotation of angle ϕ around the axis $\hat{\mathbf{n}}$, is given by [see Eq. (6.139)]

$$B(\hat{\mathbf{n}}, \phi) \doteq \exp\left(-\frac{i\boldsymbol{\sigma} \cdot \hat{\mathbf{n}}\phi}{2}\right) = \mathbf{1} \cos \frac{\phi}{2} - i\boldsymbol{\sigma} \cdot \hat{\mathbf{n}} \sin \frac{\phi}{2}, \quad (14.94)$$

and the following holds

$$B(\hat{\mathbf{n}}, \phi) |\pm\rangle = \exp\left(\mp \frac{i\phi}{2}\right) |\pm\rangle. \quad (14.95)$$

The state $|\pm(\hat{\mathbf{n}})\rangle$ is said to represent colinear (circular) polarization if $\hat{\mathbf{n}} \cdot \hat{\mathbf{y}} = 0$ ($|\hat{\mathbf{n}} \cdot \hat{\mathbf{y}}| = 1$), i.e. if $\hat{\mathbf{n}}$ is perpendicular (parallel) to $\hat{\mathbf{y}}$. For the

case where the eigenvectors $|\pm(\hat{\mathbf{n}})\rangle$ represent states of colinear (circular) polarization, the rotation $B(\hat{\mathbf{n}}, \phi)$ represents colinear (circular) birefringence. Birefringence occurs in materials having polarization dependent propagation speed. Let $c_{\pm} = c/n_{\pm}$ be the propagation speed of polarization state $|\pm(\hat{\mathbf{n}})\rangle$. The retardation of the slow polarization with respect to the fast one gives rise to polarization rotation. The rotation angle ϕ is related to the travelled distance d by

$$\phi = \frac{2\pi(n_- - n_+)d}{\lambda}, \quad (14.96)$$

where λ is the wavelength inside the material.

14.4.1 Colinear birefringence

Colinear birefringence occurs in materials having anisotropic propagation speed. Linear birefringence can be induced in materials possessing the electro-optical effect by applying an electric field E . The change δn in the refractive index n to first (second) order in the applied electric field E is attributed to the Pockels (Kerr) effect.

In general, the Jones matrix $J(\alpha)$ of an optical element that is rotated by an angle α around the optical axis (i.e. the direction of light propagation) is related to the Jones matrix $J(0)$ of the unrotated element by

$$J(\alpha) = R(-\alpha)J(0)R(\alpha), \quad (14.97)$$

where the rotation matrix $R(x)$ is given by [see Eqs. (14.94) and (6.137)]

$$R(x) = \begin{pmatrix} \cos x & -\sin x \\ \sin x & \cos x \end{pmatrix} = B(\hat{\mathbf{y}}, 2x). \quad (14.98)$$

The Jones matrix of a general linear birefringence can be expressed as

$$J_{\text{LB}}(\phi, \alpha) = B(\hat{\mathbf{y}}, -2\alpha)B(\hat{\mathbf{z}}, \phi)B(\hat{\mathbf{y}}, 2\alpha), \quad (14.99)$$

or [see Eq. (14.235)]

$$J_{\text{LB}}(\phi, \alpha) = B(\hat{\mathbf{n}}, \phi), \quad (14.100)$$

where

$$\hat{\mathbf{n}} = \hat{\mathbf{z}} \cos(2\alpha) - \hat{\mathbf{x}} \sin(2\alpha). \quad (14.101)$$

Polarization plates are commonly based on linear birefringence. For a quarter wave plate (QWP) $\phi = \pi/2$, whereas $\phi = \pi$ for a half wave plate (HWP). QWPs are commonly used to convert colinear polarization to elliptical. When the incoming light is polarized at 45° with respect to the retarder's axis a QWP converts from colinear to circular polarization (and vice versa). HWPs are commonly used to flip the colinear polarization or change the handedness of circular polarization.

14.4.2 Circular birefringence

Circular birefringence (also called optical activity) occurs in materials exhibiting chirality. Clockwise (counterclockwise) rotation of polarization is referred to as dextrorotatory (levorotatory). A magnetic field can induce optical activity via the Faraday effect. In a device based on the Faraday effect the magnetic field is applied in the direction of light propagation. The polarization rotation is proportional to the Verdet constant, the magnetic field and the traveling distance inside the magneto-optical medium [see Eq. (14.96)]. The Jones matrix $J_{\text{CB}}(\phi)$ corresponding to circular birefringence with angle ϕ is given by [see Eq. (14.98)]

$$J_{\text{CB}}(\phi) = B(\hat{\mathbf{y}}, \phi) = R\left(\frac{\phi}{2}\right). \quad (14.102)$$

14.4.3 Polarizer

The Jones matrix of a colinear polarizer whose axis is rotated by an angle α with respect to the direction of colinear vertical polarization is given by the projection matrix $J_{\text{P}}(\alpha)$ [see Eq. (14.97)]

$$\begin{aligned} J_{\text{P}}(\alpha) &= R(-\alpha) \begin{pmatrix} 1 & 0 \\ 0 & 0 \end{pmatrix} R(\alpha) \\ &= \begin{pmatrix} \cos^2 \alpha & -\frac{\sin(2\alpha)}{2} \\ -\frac{\sin(2\alpha)}{2} & \sin^2 \alpha \end{pmatrix}. \end{aligned} \quad (14.103)$$

Exercise 14.4.1. Show how a colinear polarizer and two QWPs can be used for the filtering of circular polarization.

Solution 14.4.1. The following holds [see Eq. (14.100) and (14.103)]

$$\begin{aligned} P_{\text{L}} &\equiv J_{\text{LB}}\left(\phi = \frac{\pi}{2}, \alpha = \frac{\pi}{2}\right) J_{\text{P}}\left(\frac{\pi}{4}\right) J_{\text{LB}}\left(\phi = \frac{\pi}{2}, \alpha = 0\right) \\ &= \frac{1}{2} \begin{pmatrix} 1 & -i \\ i & 1 \end{pmatrix}, \end{aligned} \quad (14.104)$$

and

$$\begin{aligned} P_{\text{R}} &\equiv J_{\text{LB}}\left(\phi = \frac{\pi}{2}, \alpha = \frac{\pi}{2}\right) J_{\text{P}}\left(-\frac{\pi}{4}\right) J_{\text{LB}}\left(\phi = \frac{\pi}{2}, \alpha = 0\right) \\ &= \frac{1}{2} \begin{pmatrix} 1 & i \\ -i & 1 \end{pmatrix}, \end{aligned} \quad (14.105)$$

hence the following holds (see table 14.1)

$$P_L |L\rangle = |L\rangle , \quad (14.106)$$

$$P_L |R\rangle = 0 , \quad (14.107)$$

$$P_R |L\rangle = 0 , \quad (14.108)$$

$$P_R |R\rangle = |R\rangle . \quad (14.109)$$

14.4.4 Mirror

Mirror reflection at normal incidence leads to the transformations $|R\rangle \rightarrow |L\rangle$ and $|L\rangle \rightarrow |R\rangle$, and thus the corresponding Jones matrix J_M can be chosen to be given by

$$|L\rangle \langle R| + |R\rangle \langle L| \doteq J_M = \sigma_z . \quad (14.110)$$

14.4.5 Time reversal symmetry

The following holds [see Eq. (14.94)]

$$B^T(\hat{\mathbf{n}}, \phi) = \begin{cases} B(\hat{\mathbf{n}}, -\phi) & \hat{\mathbf{n}} \parallel \hat{\mathbf{y}} \\ B(\hat{\mathbf{n}}, \phi) & \hat{\mathbf{n}} \perp \hat{\mathbf{y}} \end{cases} , \quad (14.111)$$

where superscript T represents matrix transpose. Hence, for the cases of colinear birefringence, a polarizer and a mirror the relations

$$J_{LB}^T = J_{LB} , \quad (14.112)$$

$$J_P^T = J_P , \quad (14.113)$$

$$J_M^T = J_M , \quad (14.114)$$

hold, and for the case of circular birefringence the relation

$$J_{CB}^T(\phi) = J_{CB}(-\phi) \quad (14.115)$$

holds.

14.4.6 Reverse propagation

Consider a given optical element having Jones matrix J . Let J^R be the Jones matrix of the same element after π rotation above the direction corresponding to $|H\rangle$ polarization.

Exercise 14.4.2. Show that for colinear birefringence, circular birefringence and for a colinear polarizer

$$J^R = \sigma_z J \sigma_z . \quad (14.116)$$

Solution 14.4.2. The following holds [see Eq. (14.98)]

$$R(x) \sigma_z R(x) = \sigma_z , \quad (14.117)$$

and [note that $B(\hat{\mathbf{z}}, \pi) = -i\sigma_z$]

$$B(\hat{\mathbf{z}}, -\phi) \sigma_z B(\hat{\mathbf{z}}, \phi) = \sigma_z . \quad (14.118)$$

For the case of colinear birefringence [see Eq. (14.99)]

$$\begin{aligned} \sigma_z J_{\text{LB}}(\phi, \alpha) \sigma_z &= \sigma_z B(\hat{\mathbf{y}}, -2\alpha) B(\hat{\mathbf{z}}, \phi) B(\hat{\mathbf{y}}, 2\alpha) \sigma_z \\ &= \sigma_z R(-\alpha) B(\hat{\mathbf{z}}, \phi) R(\alpha) \sigma_z , \end{aligned} \quad (14.119)$$

thus [see Eq. (14.117) and note that $\sigma_z^2 = 1$ and $R^{-1}(x) = R(-x)$]

$$\sigma_z J_{\text{LB}}(\phi, \alpha) \sigma_z = R(\alpha) \sigma_z B(\hat{\mathbf{z}}, \phi) \sigma_z R(-\alpha) , \quad (14.120)$$

or [see Eq. (14.118)]

$$\begin{aligned} \sigma_z J_{\text{LB}}(\phi, \alpha) \sigma_z &= R(\alpha) B(\hat{\mathbf{z}}, \phi) R(-\alpha) \\ &= J_{\text{LB}}(\phi, -\alpha) \\ &= J_{\text{LB}}^{\text{R}}(\phi, \alpha) . \end{aligned} \quad (14.121)$$

$$(14.122)$$

For the case of circular birefringence [see Eqs. (14.102) and (14.117) and recall that $\sigma_z^2 = 1$]

$$\sigma_z J_{\text{CB}}(\phi) \sigma_z = \sigma_z R\left(\frac{\phi}{2}\right) \sigma_z = R\left(-\frac{\phi}{2}\right) , \quad (14.123)$$

thus

$$\sigma_z J_{\text{CB}}(\phi) \sigma_z = J_{\text{CB}}(-\phi) = J_{\text{CB}}^{\text{R}}(\phi) . \quad (14.124)$$

For the case of a polarizer [see Eq. (14.103) and (14.117) and recall that $\sigma_z^2 = 1$]

$$\begin{aligned} \sigma_z J_{\text{P}}(\alpha) \sigma_z &= \sigma_z R(-\alpha) \begin{pmatrix} 1 & 0 \\ 0 & 0 \end{pmatrix} R(\alpha) \sigma_z \\ &= R(\alpha) \sigma_z \begin{pmatrix} 1 & 0 \\ 0 & 0 \end{pmatrix} \sigma_z R(-\alpha) \\ &= J_{\text{P}}(-\alpha) \\ &= J_{\text{P}}^{\text{R}}(\alpha) . \end{aligned} \quad (14.125)$$

For both colinear and circular birefringence, i.e. when J can be expressed as [see Eq. (14.94)]

$$J = B(\hat{\mathbf{n}}, \phi) , \quad (14.126)$$

one has [see Eqs. (14.116) and (14.240)]

$$J^R = \sigma_z B(\hat{\mathbf{n}}, \phi) \sigma_z = B((\hat{\mathbf{z}} \times \hat{\mathbf{n}}) \times \hat{\mathbf{z}} - (\hat{\mathbf{z}} \cdot \hat{\mathbf{n}}) \hat{\mathbf{z}}, -\phi) . \quad (14.127)$$

Note that the unit vector $(\hat{\mathbf{z}} \times \hat{\mathbf{n}}) \times \hat{\mathbf{z}} - (\hat{\mathbf{z}} \cdot \hat{\mathbf{n}}) \hat{\mathbf{z}}$ is the mirror reflection of the unit vector $\hat{\mathbf{n}}$ about a plane perpendicular to $\hat{\mathbf{z}}$.

14.5 Problems

1. Find the eigen modes and eigen frequencies of a cavity having a pizza box shape with volume $V = L^2 d$.
2. **Casimir force** - Consider two perfectly conducting metallic plates placed in parallel to each other. The gap between the plates is d and the temperature is assumed to be zero. Calculate the force per unit area acting between the plates.
3. Find the average energy per unit volume of the electromagnetic field in thermal equilibrium at temperature T .
4. Calculate the variance $\langle (\Delta U)^2 \rangle$ in the energy of the electromagnetic field in thermal equilibrium at temperature T .
5. Consider an electromagnetic cavity having a set of normal modes. The waveform of mode n is denoted by $\mathbf{u}_n(\mathbf{r})$, the angular frequency by ω_n , the annihilation operator by a_n , and the creation operator by a_n^\dagger . The electric field operator at point \mathbf{r} and time t can be expressed as [see Eqs. (14.6) and (14.71)]

$$\mathbf{E}(\mathbf{r}, t) = \mathbf{E}^{(-)}(\mathbf{r}, t) + \mathbf{E}^{(+)}(\mathbf{r}, t) , \quad (14.128)$$

where

$$\mathbf{E}^{(-)} = - \sum_n \sqrt{2\pi\hbar\omega_n} i e^{i\omega_n t} \mathbf{u}_n(\mathbf{r}) a_n^\dagger , \quad (14.129)$$

$$\mathbf{E}^{(+)} = \sum_n \sqrt{2\pi\hbar\omega_n} i e^{-i\omega_n t} \mathbf{u}_n(\mathbf{r}) a_n . \quad (14.130)$$

The correlation function $G^{(l)}(\mathbf{r}_1, \dots, \mathbf{r}_l; \mathbf{r}_{l+1}, \dots, \mathbf{r}_{2l})$ of degree l is defined by

$$G^{(l)}(\mathbf{r}_1, \dots, \mathbf{r}_l; \mathbf{r}_{l+1}, \dots, \mathbf{r}_{2l}) \equiv \left\langle E^{(-)}(\mathbf{r}_1) \dots E^{(-)}(\mathbf{r}_l) E^{(+)}(\mathbf{r}_{l+1}) \dots E^{(+)}(\mathbf{r}_{2l}) \right\rangle . \quad (14.131)$$

The normalized coherence function $g^{(l)}(\mathbf{r}_1, \dots, \mathbf{r}_l; \mathbf{r}_{l+1}, \dots, \mathbf{r}_{2l})$ of degree l is defined by

$$g^{(l)}(\mathbf{r}_1, \dots, \mathbf{r}_l; \mathbf{r}_{l+1}, \dots, \mathbf{r}_{2l}) \equiv \frac{G^{(l)}(\mathbf{r}_1, \dots, \mathbf{r}_l; \mathbf{r}_{l+1}, \dots, \mathbf{r}_{2l})}{\prod_{s=1}^{2l} \sqrt{G^{(1)}(\mathbf{r}_s; \mathbf{r}_s)}}. \quad (14.132)$$

Consider the case where all modes in the cavity are in their ground state except of a single mode, which is in a number state with m photons. Calculate $g^{(l)}(\mathbf{r}_1, \dots, \mathbf{r}_l; \mathbf{r}_{l+1}, \dots, \mathbf{r}_{2l})$ for such a state.

6. **quantum diffraction** - Consider the case where sources located in the left half space $z < 0$ generate a monochromatic electromagnetic field at angular frequency ω_0 . The right half space $z > 0$ is assumed to be a vacuum free of any matter and sources. Assume the paraxial case, for which the characteristic angle between the direction of propagation of the field and the z axis is assumed small. Express the vector potential operator $\mathbf{A}(\mathbf{r}, t)$ in the plane $z = z' > 0$ in terms of its value in the plane $z = 0$.
7. **parity** - Space inversion corresponds to the transformation $\mathbf{r} \rightarrow -\mathbf{r}$, i.e. $(x, y, z) \rightarrow (-x, -y, -z)$. It converts a right handed coordinate system to left handed. Under space inversion a general quantum state vector $|\psi\rangle$ is transformed to the state $\mathcal{P}|\psi\rangle$, where \mathcal{P} is the so-called parity operator [compare with Eq. (5.111)]. It is assumed that the parity operator is unitary, i.e.

$$\mathcal{P}^\dagger \mathcal{P} = 1. \quad (14.133)$$

Moreover, it is assumed that

$$\mathcal{P}|\mathbf{r}'\rangle = |-\mathbf{r}'\rangle, \quad (14.134)$$

where $|\mathbf{r}'\rangle = |x', y', z'\rangle$ is a common eigenvector of the position operators x, y and z with eigenvalues x', y' and z' , respectively, i.e. [see Eq. (3.61)]

$$\mathbf{r}|\mathbf{r}'\rangle = \mathbf{r}'|\mathbf{r}'\rangle. \quad (14.135)$$

- a) Show that $\mathcal{P}^\dagger = \mathcal{P}$ and that $\mathcal{P}^2 = 1$.
 b) Show that the eigenvalues of the operator \mathcal{P} can be only ± 1 .
 c) Show that

$$\mathcal{P}^\dagger \mathbf{r} \mathcal{P} = -\mathbf{r}, \quad (14.136)$$

where $\mathbf{r} = (x, y, z)$ is the position vector operator.

- d) Geometrically, it is expected that for any translation $\Delta = (\Delta_x, \Delta_y, \Delta_z) \in \mathcal{R}^3$, the following holds

$$\mathcal{P}J(\Delta) = J(-\Delta)\mathcal{P}, \quad (14.137)$$

where $J(\Delta) = \exp(-i\hbar^{-1}\Delta \cdot \mathbf{p})$ is the translation operator [see Eq. (3.73)], and where $\mathbf{p} = (p_x, p_y, p_z)$ is the momentum vector operator. Show that the assumption that Eq. (14.137) holds implies that

$$\mathcal{P}^\dagger \mathbf{p} \mathcal{P} = -\mathbf{p}, \quad (14.138)$$

e) Show that

$$[\mathcal{P}, \mathbf{L}] = 0, \quad (14.139)$$

where \mathbf{L} is the orbital angular momentum vector operator.

f) Show that

$$\mathcal{P}|l, m\rangle = (-1)^l |l, m\rangle, \quad (14.140)$$

where $|l, m\rangle$ is an orbital angular momentum eigenvector [see Eqs. (6.107) and (6.108)].

g) **parity selection rule** - Show that $\langle l_f, m_f | \mathbf{r} | l_i, m_i \rangle \neq 0$ implies that $1 + l_f - l_i$ is even [compare with the selection rule (15.26)].

8. **two-photon states** - Consider the four two-photon states $|+, +\rangle, |+, -\rangle, |-, +\rangle$ and $|-, -\rangle$, where

$$|\lambda_1, \lambda_2\rangle = a_{k\hat{\mathbf{z}}, \lambda_1}^\dagger a_{-k\hat{\mathbf{z}}, \lambda_2}^\dagger |0\rangle, \quad (14.141)$$

where the operator $a_{k\hat{\mathbf{z}}, +}^\dagger$ ($a_{k\hat{\mathbf{z}}, -}^\dagger$) creates a photon having wave vector $k\hat{\mathbf{z}}$ and right (left) handed circular polarization, the operator $a_{-k\hat{\mathbf{z}}, +}^\dagger$ ($a_{-k\hat{\mathbf{z}}, -}^\dagger$) creates a photon having wave vector $-k\hat{\mathbf{z}}$ and right (left) handed circular polarization, and $|0\rangle$ is the vacuum state. Construct an orthonormal basis to the subspace spanned by the vectors $|+, +\rangle, |+, -\rangle, |-, +\rangle$ and $|-, -\rangle$ made of eigenvectors of both the space inversion parity operator \mathcal{P} [see Eq. (14.134)] and the angular momentum operator $M_{F_z} = \mathbf{M}_F \cdot \hat{\mathbf{z}}$.

9. Express the 2×2 Jones matrix J in terms of a matrix having the form $B(\hat{\mathbf{n}}, \phi)$ [see Eq. (14.94)] for the case where

a) The matrix J is given by $J = u_2 u_1$, where $u_l = B(\hat{\mathbf{n}}_l, \phi_l)$ for $l \in \{1, 2\}$ [see Eq. (14.94)].

b) The matrix J is given by $J = B(\hat{\mathbf{n}}_1, -\phi_1) B(\hat{\mathbf{n}}_2, \phi_2) B(\hat{\mathbf{n}}_1, \phi_1)$, and $\hat{\mathbf{n}}_1 \cdot \hat{\mathbf{n}}_2 = 0$.

c) The matrix J is given by $J = (\boldsymbol{\sigma} \cdot \hat{\mathbf{n}}_1) B(\hat{\mathbf{n}}_2, \phi_2) (\boldsymbol{\sigma} \cdot \hat{\mathbf{n}}_1)$.

10. **Faraday mirror** - Consider an optical element having Jones matrix $J = B(\hat{\mathbf{n}}, \phi)$ [see Eq. (14.94)] serially connected to a circular birefringence element having Jones matrix J_{CB} given by

$$J_{CB} = B\left(\hat{\mathbf{y}}, \frac{\pi}{2}\right), \quad (14.142)$$

and a mirror. Calculate the Jones matrix $J_{\text{FMS}} = J^{\text{R}} J_{\text{CB}}^{\text{R}} J_{\text{M}} J_{\text{CB}} J$ corresponding to reflection (transmission through both elements, reflection off the mirror, and second transmission through both elements).

11. Consider two Jones matrices $J_l = B(\hat{\mathbf{n}}_l, \phi_l)$ with $l \in \{1, 2\}$ [see Eq. (14.94)]. Show that $J_1 J_2 = (J_2 J_1)^{\text{T}}$ provided that both J_1 and J_2 represent colinear birefringence.

14.6 Solutions

1. We seek solutions of Eq. (14.16) satisfying the boundary condition that the tangential component of \mathbf{u} vanishes on the walls. Consider a solution having the form

$$u_x(\mathbf{r}) = \sqrt{\frac{8}{V}} a_x \cos(k_x x) \sin(k_y y) \sin(k_z z) , \quad (14.143)$$

$$u_y(\mathbf{r}) = \sqrt{\frac{8}{V}} a_y \sin(k_x x) \cos(k_y y) \sin(k_z z) , \quad (14.144)$$

$$u_z(\mathbf{r}) = \sqrt{\frac{8}{V}} a_z \sin(k_x x) \sin(k_y y) \cos(k_z z) . \quad (14.145)$$

While the boundary condition on the walls $x = 0$, $y = 0$, and $z = 0$ is guaranteed to be satisfied, the boundary condition on the walls $x = L$, $y = L$, and $z = d$ yields

$$k_x = \frac{n_x \pi}{L} , \quad (14.146)$$

$$k_y = \frac{n_y \pi}{L} , \quad (14.147)$$

$$k_z = \frac{n_z \pi}{d} , \quad (14.148)$$

where n_x , n_y and n_z are integers. This solution clearly satisfies Eq. (14.16), where the eigenvalue κ is given by

$$\kappa = \sqrt{k_x^2 + k_y^2 + k_z^2} . \quad (14.149)$$

Alternatively, using the notation $\mathbf{n} = (n_x, n_y, n_z)$ one has $\kappa = (\pi/L) n$, where $n = \sqrt{n_x^2 + n_y^2 + n_z^2}$. Using Eq. (14.24) one finds that the angular frequency of a mode characterized by the vector of integers \mathbf{n} is given by

$$\omega_{\mathbf{n}} = c\pi \sqrt{\left(\frac{n_x}{L}\right)^2 + \left(\frac{n_y}{L}\right)^2 + \left(\frac{n_z}{d}\right)^2} . \quad (14.150)$$

In addition to Eq. (14.16) and the boundary condition, each solution has to satisfy also the transversality condition $\nabla \cdot \mathbf{u} = 0$ (14.19), which in the present case reads

$$\mathbf{k} \cdot \mathbf{a} = 0, \quad (14.151)$$

where $\mathbf{k} = (k_x, k_y, k_z)$ and $\mathbf{a} = (a_x, a_y, a_z)$. Thus, for each set of integers $\{n_x, n_y, n_z\}$ there are two orthogonal modes (polarizations), unless $n_x = 0$ or $n_y = 0$ or $n_z = 0$. In the latter case, only a single solution exists. The inner product between two solutions \mathbf{u}_1 and \mathbf{u}_2 having vectors of integers $\mathbf{n}_1 = (n_{x1}, n_{y1}, n_{z1})$ and $\mathbf{n}_2 = (n_{x2}, n_{y2}, n_{z2})$, and vectors of amplitudes $\mathbf{a}_1 = (a_{x1}, a_{y1}, a_{z1})$ and $\mathbf{a}_2 = (a_{x2}, a_{y2}, a_{z2})$, respectively, can be calculated using Eq. (14.28)

$$\begin{aligned} \langle \mathbf{u}_1, \mathbf{u}_2 \rangle &= \int_V (\mathbf{u}_1 \cdot \mathbf{u}_2) dV \\ &= \int_V (u_{x1}u_{x2} + u_{y1}u_{y2} + u_{z1}u_{z2}) dV. \end{aligned} \quad (14.152)$$

The following holds

$$\begin{aligned} &\int_V u_{x1}u_{x2}dV \\ &= \frac{8}{V}a_{x1}a_{x2} \\ &\quad \times \int_0^L \cos\left(\frac{n_{x1}\pi}{L}x\right) \cos\left(\frac{n_{x2}\pi}{L}x\right) dx \\ &\quad \times \int_0^L \sin\left(\frac{n_{y1}\pi}{L}y\right) \sin\left(\frac{n_{y2}\pi}{L}y\right) dy \\ &\quad \times \int_0^d \sin\left(\frac{n_{z1}\pi}{d}z\right) \sin\left(\frac{n_{z2}\pi}{d}z\right) dz, \\ &= \frac{8}{V}a_{x1}a_{x2} \frac{L^2d}{8} \delta_{n_{x1},n_{x2}} \delta_{n_{y1},n_{y2}} \delta_{n_{z1},n_{z2}}. \end{aligned} \quad (14.153)$$

Similar results are obtained for the contribution of the y and z components. Thus

$$\langle \mathbf{u}_1, \mathbf{u}_2 \rangle = (\mathbf{a}_1 \cdot \mathbf{a}_2) \delta_{n_{x1},n_{x2}} \delta_{n_{y1},n_{y2}} \delta_{n_{z1},n_{z2}}, \quad (14.154)$$

and therefore the vectors of amplitudes \mathbf{a} are required to be normalized, i.e. to satisfy $\mathbf{a} \cdot \mathbf{a} = 1$, in order to ensure that the solutions \mathbf{u} are normalized.

- Employing the results of the previous exercise, the eigen frequencies $\omega_{\mathbf{n}}$ are taken to be given by Eq. (14.150), where L is assumed to be much larger than d . As can be seen from Eq. (14.68), each mode contributes energy of $\hbar\omega_{\mathbf{n}}/2$ to the total energy of the ground state of the system, which is denoted by $E(d)$. Let $E(\infty)$ be the ground state energy in the limit where $d \rightarrow \infty$ and let $U(d) = E(d) - E(\infty)$ be the potential energy

of the system. Formally, both $E(d)$ and $E(\infty)$ are infinite, however, as we will show below, the divergence can be regulated when evaluating the difference $U(d)$. The assumption that L is large allows substituting the discrete sums over n_x and n_y by integrals when evaluating $E(d)$ and $E(\infty)$. Moreover the discrete sum over n_z is substituted by an integral in the expression for $E(\infty)$. The prime on the summation symbol over n_z in the expression for $E(d)$ below implies that a factor of $1/2$ should be inserted if $n_z = 0$, when only one polarization exists (see previous exercise). Using these approximations and notation one has

$$\begin{aligned} U(d) &= E(d) - E(\infty) \\ &= \hbar c \left(\frac{L}{\pi}\right)^2 \sum'_{n_z} \int_0^\infty dk_x \int_0^\infty dk_y \sqrt{k_x^2 + k_y^2 + \left(\frac{\pi n_z}{d}\right)^2} \\ &\quad - \hbar c \left(\frac{L}{\pi}\right)^2 \frac{d}{\pi} \int_0^\infty dk_x \int_0^\infty dk_y \int_0^\infty dk_z \sqrt{k_x^2 + k_y^2 + k_z^2}. \end{aligned} \quad (14.155)$$

In polar coordinates $u = \sqrt{k_x^2 + k_y^2}$ and $\theta = \tan^{-1}(k_y/k_x)$ one has $dk_x dk_y = u du d\theta$, thus

$$\begin{aligned} U(d) &= \hbar c \left(\frac{L}{\pi}\right)^2 \frac{\pi}{2} \sum'_{n_z} \int_0^\infty du u \sqrt{u^2 + \left(\frac{\pi n_z}{d}\right)^2} \\ &\quad - \hbar c \left(\frac{L}{\pi}\right)^2 \frac{d}{\pi} \frac{\pi}{2} \int_0^\infty du u \int_0^\infty dk_z \sqrt{u^2 + k_z^2}. \end{aligned} \quad (14.156)$$

Changing the integration variables

$$x = \left(\frac{ud}{\pi}\right)^2, \quad (14.157)$$

$$N_z = \frac{k_z d}{\pi}, \quad (14.158)$$

leads to

$$\begin{aligned} U(d) &= \frac{\pi^2 \hbar c L^2}{4d^3} \left(\sum'_{n_z} F(n_z) - \int_0^\infty dN_z F(N_z) \right) \\ &= \frac{\pi^2 \hbar c L^2}{4d^3} \left(\frac{1}{2} F(0) + \sum_{n_z=1}^\infty F(n_z) - \int_0^\infty dN_z F(N_z) \right), \end{aligned} \quad (14.159)$$

where the function $F(\xi)$ is given by

$$F(\xi) = \int_0^\infty dx \sqrt{x + \xi^2} = \int_{\xi^2}^\infty dy \sqrt{y}. \quad (14.160)$$

Formally, the function $F(\xi)$ diverges. However, the following physical argument can be employed in order to regulate this divergency. The assumption that the walls of the cavity perfectly conduct is applicable at low frequencies. However, any metal becomes effectively transparent in the limit of high frequencies. Thus, the contribution to the ground state energy of high frequency modes is expected to be effectively d independent, and consequently $U(d)$ is expected to become finite. Based on this argument the divergency in $F(\xi)$ is removed by introducing a cutoff function $f(y)$ into the integrand in Eq. (14.160)

$$F(\xi) = \int_{\xi^2}^{\infty} dy \sqrt{y} f(y) . \quad (14.161)$$

While near $y = 0$ (low frequencies) the cutoff function is assumed to be given by $f(y) = 1$, in the limit of large y (high frequencies) the function $f(y)$ is assumed to approach zero sufficiently fast to ensure that $F(\xi)$ is finite for any ξ . Moreover, it is assumed that $F(\infty) \rightarrow 0$. In this case the Euler-Maclaurin summation formula, which is given by

$$\frac{1}{2}F(0) + \sum_{n=1}^{\infty} F(n) - \int_0^{\infty} dN F(N) = -\frac{1}{12}F'(0) + \frac{1}{720}F'''(0) + \dots , \quad (14.162)$$

can be employed to evaluate $U(d)$. The following holds

$$F'(\xi) = -2\xi^2 f(\xi^2) , \quad (14.163)$$

thus for small ξ [where the cutoff function is assumed to be given by $f(y) = 1$] $F''(\xi) = -4\xi$ and $F'''(\xi) = -4$, and therefore

$$U(d) = -\frac{\pi^2 \hbar c L^2}{720 d^3} . \quad (14.164)$$

The force per unit area (pressure) $P(d)$ is found by taking the derivative with respect to d and by dividing by the area L^2

$$P(d) = -\frac{\pi^2 \hbar c}{240 d^4} . \quad (14.165)$$

The minus sign indicates that the force is attractive.

3. The average energy U in thermal equilibrium is given by Eq. (8.624), which is given by

$$U = -\frac{\partial \log Z_c}{\partial \beta} , \quad (14.166)$$

where $Z_c = \text{Tr}(e^{-\beta \mathcal{H}})$ is the canonical partition function, \mathcal{H} is the Hamiltonian [see Eq. (14.68)], $\beta = 1/(k_B T)$ and k_B is the Boltzmann's

constant. The partition function is found by summing over all photon-number states $|s_1, s_2, \dots\rangle$

$$\begin{aligned}
 Z_c &= \sum_{s_1, s_2, \dots=0}^{\infty} \langle s_1, s_2, \dots | e^{-\beta \mathcal{H}} | s_1, s_2, \dots \rangle \\
 &= \sum_{s_1, s_2, \dots=0}^{\infty} e^{-\beta \sum_n \hbar \omega_n (s_n + \frac{1}{2})} \\
 &= \prod_n \left(\sum_{s_n=0}^{\infty} e^{-\beta \hbar \omega_n (s_n + \frac{1}{2})} \right) \\
 &= \prod_n \left(\frac{1}{2 \sinh \frac{\beta \hbar \omega_n}{2}} \right),
 \end{aligned} \tag{14.167}$$

where n labels the cavity modes. Using the last result one finds that

$$\begin{aligned}
 U &= -\frac{\partial \log Z_c}{\partial \beta} \\
 &= -\sum_n \frac{\partial \log \left(\frac{1}{2 \sinh \frac{\beta \hbar \omega_n}{2}} \right)}{\partial \beta} \\
 &= \sum_n \frac{\hbar \omega_n}{2} \coth \frac{\beta \hbar \omega_n}{2}.
 \end{aligned} \tag{14.168}$$

It is easy to see that the above sum diverges since the number of modes in the cavity is infinite. To obtain a finite result we evaluate below the difference $U_d = U(T) - U(T=0)$ between the energy at temperature T and the energy at zero temperature, which is given by (recall that $\coth(x) \rightarrow 1$ in the limit $x \rightarrow \infty$)

$$\begin{aligned}
 U_d &= \sum_n \frac{\hbar \omega_n}{2} \left(\coth \frac{\beta \hbar \omega_n}{2} - 1 \right) \\
 &= \sum_n \frac{\hbar \omega_n}{e^{\beta \hbar \omega_n} - 1}.
 \end{aligned} \tag{14.169}$$

The angular frequencies ω_n of the modes are given by Eq. (14.150). For simplicity a cubical cavity having volume $V = L^3$ is considered. For this case U_d is given by (the factor of 2 is due to polarization degeneracy)

$$U_d = 2k_B T \sum_{n_x=0}^{\infty} \sum_{n_y=0}^{\infty} \sum_{n_z=0}^{\infty} \frac{\alpha n}{e^{\alpha n} - 1}. \tag{14.170}$$

where $n = \sqrt{n_x^2 + n_y^2 + n_z^2}$, and where the dimensionless parameter α is given by

$$\alpha = \frac{\pi\beta\hbar c}{L}. \quad (14.171)$$

In the limit where $\alpha \ll 1$ (macroscopic limit) the sum can be approximated by the integral

$$\begin{aligned} U_d &= 2k_B T \frac{4\pi}{8} \int_0^\infty dn n^2 \frac{\alpha n}{e^{\alpha n} - 1} \\ &= \frac{\pi k_B T}{\alpha^3} \underbrace{\int_0^\infty \frac{x^3 dx}{e^x - 1}}_{\frac{\pi^4}{15}}, \end{aligned} \quad (14.172)$$

thus the energy per unit volume is given by

$$\frac{U_d}{V} = \frac{\pi^2 (k_B T)^4}{15\hbar^3 c^3}. \quad (14.173)$$

4. In general, the energy variance $\langle (\Delta U)^2 \rangle$ in thermal equilibrium of a system having Hamiltonian \mathcal{H} can be expressed as [see Eqs. (8.10) and (8.36)]

$$\langle (\Delta U)^2 \rangle = \langle \mathcal{H}^2 \rangle - \langle \mathcal{H} \rangle^2 = \text{Tr}(\rho \mathcal{H}^2) - (\text{Tr}(\rho \mathcal{H}))^2, \quad (14.174)$$

where the density operator ρ is given by

$$\rho = \frac{e^{-\beta \mathcal{H}}}{Z}, \quad (14.175)$$

the partition function Z is given by

$$Z = \text{Tr}(e^{-\beta \mathcal{H}}), \quad (14.176)$$

and $\beta = 1/(k_B T)$, thus

$$\langle (\Delta U)^2 \rangle = \frac{1}{Z} \frac{d^2 Z}{d\beta^2} - \left(\frac{1}{Z} \frac{dZ}{d\beta} \right)^2 = \frac{d^2 \log Z}{d\beta^2}, \quad (14.177)$$

or [see Eq. (8.624)]

$$\langle (\Delta U)^2 \rangle = -\frac{d\langle U \rangle}{d\beta}. \quad (14.178)$$

The last result together with Eq. (14.173) yield for the case of electromagnetic field

$$\langle (\Delta U)^2 \rangle = \frac{4\pi^2 V (k_B T)^5}{15\hbar^3 c^3}, \quad (14.179)$$

where V is the volume.

5. When only a single mode in the cavity is excited the normalized coherence function $g^{(l)}(\mathbf{r}_1, \dots, \mathbf{r}_l; \mathbf{r}_{l+1}, \dots, \mathbf{r}_{2l})$ becomes [see Eqs. (14.129) and (14.130) and the definition of $g^{(l)}$]

$$g^{(l)}(\mathbf{r}_1, \dots, \mathbf{r}_l; \mathbf{r}_{l+1}, \dots, \mathbf{r}_{2l}) = \frac{\langle (a^\dagger)^l a^l \rangle}{\langle a^\dagger a \rangle^l}, \quad (14.180)$$

where a and a^\dagger are the annihilation and creation operators of the excited cavity mode. With the help of the relation $a|m\rangle = \sqrt{m}|m-1\rangle$ [see Eq. (5.28)] one finds that for the given single mode m photon state $g^{(l)}$ is given by

$$g^{(l)} = \begin{cases} \frac{m!}{(m-l)!l!} & m \geq l \\ 0 & m < l \end{cases}. \quad (14.181)$$

6. In general, the vector potential operator $\mathbf{A}(\mathbf{r}, t)$ is given by [see Eqs. (14.73) and (14.74)]

$$\mathbf{A}(\mathbf{r}, t) = \mathbf{A}^{(-)}(\mathbf{r}, t) + \left(\mathbf{A}^{(-)}(\mathbf{r}, t)\right)^\dagger, \quad (14.182)$$

where $\mathbf{A}^{(-)}(\mathbf{r}, t)$ is given by

$$\mathbf{A}^{(-)}(\mathbf{r}, t) = \sqrt{\frac{c^2 \hbar V}{(2\pi)^5}} \sum_{\lambda} \int_{-\infty}^{\infty} dk_x \int_{-\infty}^{\infty} dk_y \int_{-\infty}^{\infty} dk_z \omega^{-1/2} \hat{\mathbf{e}}_{\mathbf{k}, \lambda} e^{i(\mathbf{k} \cdot \mathbf{r} - \omega t)} a_{\mathbf{k}, \lambda}, \quad (14.183)$$

and where $\omega = c|\mathbf{k}|$. For given values of ω , k_x and k_y the component k_z is given by

$$k_z = \pm \frac{\omega}{c} \sqrt{1 - \frac{c^2(k_x^2 + k_y^2)}{\omega^2}}. \quad (14.184)$$

In the current problem under consideration the mapping from the plane $z = 0$ to the plane $z = z' > 0$ is considered, and therefore only positive values of the component k_z are expected to contribute, and thus the plus sign is chosen in Eq. (14.184). The variable transformation given by Eq. (14.184) allows rewriting Eq. (14.183) as

$$\mathbf{A}^{(-)}(\mathbf{r}, t) = \sqrt{\frac{c^2 \hbar V}{(2\pi)^5}} \sum_{\lambda} \int' dk_x dk_y \int_0^{\infty} d\omega \frac{dk_z}{d\omega} \omega^{-1/2} \hat{\mathbf{e}}_{\mathbf{k}, \lambda} e^{i(\mathbf{k} \cdot \mathbf{r} - \omega t)} a_{\mathbf{k}, \lambda}, \quad (14.185)$$

where [see Eq. (14.184)]

$$\frac{dk_z}{d\omega} = \frac{\omega}{c^2 k_z}, \quad (14.186)$$

the wave vector \mathbf{k} is given by $\mathbf{k} = (k_x, k_y, k_z)$, and the component k_z is given in terms of the integration variables k_x, k_y and ω by Eq. (14.184). The symbol \int' in Eq. (14.185) represents integration over values of k_x and k_y for which k_z is real, i.e. $k_x^2 + k_y^2 < \omega^2/c^2$ [see Eq. (14.184)]. The following commutation relations hold [see Eqs. (14.75), (14.76) and (14.184)]

$$[a_{\mathbf{k}, \lambda}, a_{\mathbf{k}', \lambda}] = [a_{\mathbf{k}, \lambda}^{\dagger}, a_{\mathbf{k}', \lambda}^{\dagger}] = 0, \quad (14.187)$$

and

$$[a_{\mathbf{k}, \lambda}, a_{\mathbf{k}', \lambda'}^{\dagger}] = \delta_{\lambda, \lambda'} \frac{\delta(\omega - \omega')}{\left| \frac{dk_z}{d\omega} \right|} \delta(k_x - k'_x) \delta(k_y - k'_y). \quad (14.188)$$

For the case of a monochromatic electromagnetic field at angular frequency ω_0 the paraxial assumption implies that the dominant contribution to the integral in Eq. (14.185) arises from Fourier components for which

$$\frac{c^2 (k_x^2 + k_y^2)}{\omega_0^2} \ll 1. \quad (14.189)$$

Thus, in the paraxial approximation the commutation relations (14.188) approximately become [see Eq. (14.186)]

$$[a_{\mathbf{k}, \lambda}, a_{\mathbf{k}', \lambda'}^{\dagger}] = c \delta_{\lambda, \lambda'} \delta(\omega - \omega') \delta(k_x - k'_x) \delta(k_y - k'_y), \quad (14.190)$$

and the restricted integration \int' in Eq. (14.185) can be replaced by an integration over the entire $k_x k_y$ plane

$$\mathbf{A}^{(-)}(\mathbf{r}, t) = \sqrt{\frac{\hbar \omega_0 V}{(2\pi)^5 c^2}} \sum_{\lambda} \int_{-\infty}^{\infty} dk_x \int_{-\infty}^{\infty} dk_y \int_0^{\infty} d\omega \frac{e^{i(\mathbf{k} \cdot \mathbf{r} - \omega t)}}{k_z} \hat{\mathbf{e}}_{\mathbf{k}, \lambda} a_{\mathbf{k}, \lambda}. \quad (14.191)$$

For any value of z the operator $\mathbf{A}^{(-)}(\mathbf{r}, t)$ can be Fourier expanded with respect to the spatial coordinates x and y and the time coordinate t . The Fourier transformed operator $\mathbf{A}^{(-)}(k_x, k_y, z, \omega)$ is defined by

$$\begin{aligned}
\mathbf{A}^{(-)}(k_x, k_y, z, \omega) &= \mathcal{F}\left(\mathbf{A}^{(-)}(x, y, z, t)\right) \\
&= \frac{1}{(2\pi)^{3/2}} \int_{-\infty}^{\infty} \int_{-\infty}^{\infty} dx dy \int_{-\infty}^{\infty} dt \mathbf{A}^{(-)}(x, y, z, t) e^{-i(k_x x + k_y y + \omega t)}.
\end{aligned} \tag{14.192}$$

By applying the Fourier transform to Eq. (14.191) one finds that the following holds [recall the identity (4.47)]

$$\mathbf{A}^{(-)}(k_x, k_y, z, \omega) = \mathbf{A}^{(-)}(k_x, k_y, z = 0, \omega) e^{ik_z z}. \tag{14.193}$$

The inverse Fourier transform, which is given by

$$\begin{aligned}
&\mathcal{F}^{-1}\left(\mathbf{A}^{(-)}(k_x, k_y, z, \omega)\right) \\
&= \frac{1}{(2\pi)^{3/2}} \int_{-\infty}^{\infty} \int_{-\infty}^{\infty} dk_x dk_y \int_{-\infty}^{\infty} d\omega \mathbf{A}^{(-)}(k_x, k_y, z, \omega) e^{i(k_x x + k_y y + \omega t)},
\end{aligned} \tag{14.194}$$

satisfies the following relation [see Eq. (4.47)]

$$\mathcal{F}^{-1}\left(\mathcal{F}\left(\mathbf{A}^{(-)}(x, y, z, t)\right)\right) = \mathbf{A}^{(-)}(x, y, z, t), \tag{14.195}$$

and thus $\mathbf{A}^{(-)}(x', y', z = z', t)$ can be expressed in terms of $\mathbf{A}^{(-)}(x'', y'', z = 0, t)$ as [see Eqs. (14.192), (14.193) and (14.195)]

$$\mathbf{A}^{(-)}(x', y', z', t') = \int_{-\infty}^{\infty} \int_{-\infty}^{\infty} dx'' dy'' \int_{-\infty}^{\infty} dt'' \mathbf{A}^{(-)}(x'', y'', 0, t'') \frac{\partial G(\mathbf{r}' - \mathbf{r}'', t' - t'')}{\partial z''}, \tag{14.196}$$

where the function $G(\mathbf{r}, t)$ is given by

$$G(\mathbf{r}, t) = \frac{i}{(2\pi)^3} \int_{-\infty}^{\infty} \int_{-\infty}^{\infty} dk_x dk_y \int_{-\infty}^{\infty} d\omega \frac{e^{i(\mathbf{k}\cdot\mathbf{r} - \omega t)}}{k_z}. \tag{14.197}$$

For the case of a monochromatic field the operators $\mathbf{A}^{(-)}(x'', y'', 0, t'')$ and $\mathbf{A}^{(-)}(x', y', z', t')$ are expressed as

$$\mathbf{A}^{(-)}(x'', y'', 0, t'') = \mathbf{A}^{(-)}(x'', y'', 0) e^{-\omega_0 t''}, \tag{14.198}$$

$$\mathbf{A}^{(-)}(x', y', z', t') = \mathbf{A}^{(-)}(x', y', z') e^{-\omega_0 t'}. \tag{14.199}$$

Substituting into Eq. (14.196) yields the following relation between the time independent operators $\mathbf{A}^{(-)}(x'', y'', 0)$ and $\mathbf{A}^{(-)}(x', y', z')$ [see Eq. (4.47)]

$$\mathbf{A}^{(-)}(x', y', z') = 2 \int_{-\infty}^{\infty} \int_{-\infty}^{\infty} dx'' dy'' \mathbf{A}^{(-)}(x'', y'', 0) \frac{\partial g(\mathbf{r}' - \mathbf{r}'')}{\partial z''}, \quad (14.200)$$

where the so-called Green's function $g(\mathbf{r})$ is given by

$$g(\mathbf{r}) = \frac{i}{8\pi^2} \int_{-\infty}^{\infty} dk_x \int_{-\infty}^{\infty} dk_y \frac{e^{i\mathbf{k}\cdot\mathbf{r}}}{k_z}. \quad (14.201)$$

With the help of the so-called Weyl's plane waves expansion the function $g(\mathbf{r})$ can be expressed as

$$g(\mathbf{r}) = -\frac{e^{ikr}}{4\pi r}, \quad (14.202)$$

where $r = \sqrt{x^2 + y^2 + z^2}$. The above result (14.200) is known as the Rayleigh-Sommerfeld first diffraction integral.

7. The relations (14.133) and (14.134) imply that

$$|\mathbf{r}'\rangle = \mathcal{P}^\dagger |-\mathbf{r}'\rangle. \quad (14.203)$$

- a) The above result (14.203), which can be rewritten as $\mathcal{P}^\dagger |\mathbf{r}'\rangle = |-\mathbf{r}'\rangle$, implies that $\mathcal{P}^\dagger = \mathcal{P}$, hence $\mathcal{P}^2 = 1$ [see Eq. (14.133)].
- b) Since $\mathcal{P}^2 = 1$, any eigenvalue λ must satisfy the relation $\lambda^2 = 1$.
- c) For any common eigenvector $|\mathbf{r}'\rangle = |(x', y', z')\rangle$ of the position vector operator $\mathbf{r} = (x, y, z)$ the following holds [see Eqs. (14.134) and (14.135)]

$$(x\mathcal{P} + \mathcal{P}x)|\mathbf{r}'\rangle = -x' |-\mathbf{r}'\rangle + x' |-\mathbf{r}'\rangle = 0. \quad (14.204)$$

In a similar way one can show that $y\mathcal{P} + \mathcal{P}y = 0$ and $z\mathcal{P} + \mathcal{P}z = 0$, hence Eq. (14.136) holds [see Eq. (14.133)].

- d) To first order in Δ [see Eq. (14.137)]

$$\mathcal{P}(1 - i\hbar^{-1}\Delta \cdot \mathbf{p}) = (1 + i\hbar^{-1}\Delta \cdot \mathbf{p})\mathcal{P}, \quad (14.205)$$

thus Eq. (14.138) holds [see Eq. (14.133)].

- e) The relations (14.136) and (14.138) imply that

$$\mathcal{P}^\dagger \mathbf{L} \mathcal{P} = (-\mathbf{r}) \times (-\mathbf{p}) = \mathbf{L}, \quad (14.206)$$

thus Eq. (14.139) holds [see Eq. (14.133)].

- f) Space inversion in spherical coordinates (r, θ, ϕ) is associated with the transformation $(r, \theta, \phi) \rightarrow (r, \pi - \theta, \phi + \pi)$. As can be seen from the expression for the spherical harmonic function $Y_l^m(\theta, \phi)$ given

by Eq. (6.129), the following holds [note that $\sin(\pi - \theta) = \sin \theta$ and $\cos(\pi - \theta) = -\cos \theta$]

$$\begin{aligned} Y_l^m(\pi - \theta, \phi + \pi) &= (-1)^m (-1)^{l-m} Y_l^m(\theta, \phi) \\ &= (-1)^l Y_l^m(\theta, \phi) , \end{aligned} \quad (14.207)$$

hence Eq. (14.140) holds.

g) The following holds [see Eqs. (14.136) and (14.140)]

$$\begin{aligned} \langle l_f, m_f | \mathbf{r} | l_i, m_i \rangle &= -\langle l_f, m_f | \mathcal{P}^\dagger \mathbf{r} \mathcal{P} | l_i, m_i \rangle \\ &= (-1)^{1+l_f+l_i} \langle l_f, m_f | \mathbf{r} | l_i, m_i \rangle , \end{aligned} \quad (14.208)$$

thus [note that $(-1) = 1/(-1)$]

$$\langle l_f, m_f | \mathbf{r} | l_i, m_i \rangle = (-1)^{1+l_f-l_i} \langle l_f, m_f | \mathbf{r} | l_i, m_i \rangle , \quad (14.209)$$

hence $\langle l_f, m_f | \mathbf{r} | l_i, m_i \rangle \neq 0$ implies that $1 + l_f - l_i$ is even.

8. The parity operator reverses \mathcal{P} the direction of propagation (i.e. direction of the wave vector). On the other hand the vector $\tilde{\mathbf{e}}_{\mathbf{k}', \lambda'}^* \times \tilde{\mathbf{e}}_{\mathbf{k}', \lambda'}$ remains unchanged under space inversion, and therefore λ' changes sign under this transformation, and thus the following holds

$$\mathcal{P} |+, +\rangle = |-, -\rangle , \quad (14.210)$$

$$\mathcal{P} |+, -\rangle = |+, -\rangle , \quad (14.211)$$

$$\mathcal{P} |-, +\rangle = |-, +\rangle , \quad (14.212)$$

$$\mathcal{P} |-, -\rangle = |+, +\rangle . \quad (14.213)$$

As can be seen from Eq. (14.90), the following holds

$$M_{Fz} |\lambda_1, \lambda_2\rangle = (\lambda_1 - \lambda_2) \hbar |\lambda_1, \lambda_2\rangle . \quad (14.214)$$

Thus, the desired orthonormal basis of common eigenvectors of \mathcal{P} and M_{Fz} can be taken to be given by $\{|\psi_{0,0}\rangle, |\psi_{1,1}\rangle, |\psi_{1,0}\rangle, |\psi_{1,-1}\rangle\}$, where [compare with Eqs. (6.688), (6.689), (6.690) and (6.691)]

$$|\psi_{0,0}\rangle = \frac{|+, +\rangle - |-, -\rangle}{\sqrt{2}} , \quad (14.215)$$

$$|\psi_{1,1}\rangle = |+, -\rangle , \quad (14.216)$$

$$|\psi_{1,0}\rangle = \frac{|+, +\rangle + |-, -\rangle}{\sqrt{2}} , \quad (14.217)$$

$$|\psi_{1,-1}\rangle = |-, +\rangle , \quad (14.218)$$

and the following holds

$$\mathcal{P} |\psi_{0,0}\rangle = -|\psi_{0,0}\rangle , \quad (14.219)$$

$$\mathcal{P} |\psi_{1,1}\rangle = |\psi_{1,1}\rangle , \quad (14.220)$$

$$\mathcal{P} |\psi_{1,0}\rangle = |\psi_{1,0}\rangle , \quad (14.221)$$

$$\mathcal{P} |\psi_{1,-1}\rangle = |\psi_{1,-1}\rangle , \quad (14.222)$$

and

$$M_{Fz} |\psi_{0,0}\rangle = 0, \quad (14.223)$$

$$M_{Fz} |\psi_{1,1}\rangle = 2\hbar |\psi_{1,1}\rangle, \quad (14.224)$$

$$M_{Fz} |\psi_{1,0}\rangle = 0, \quad (14.225)$$

$$M_{Fz} |\psi_{1,-1}\rangle = -2\hbar |\psi_{1,-1}\rangle. \quad (14.226)$$

9. Note that over-hat denotes a unit vector.

a) With the help of Eq. (6.139) one finds that [see Eq. (6.138)]

$$\begin{aligned} J &= \left(\mathbf{1} \cos \frac{\phi_2}{2} - i\boldsymbol{\sigma} \cdot \hat{\mathbf{n}}_2 \sin \frac{\phi_2}{2} \right) \\ &\times \left(\mathbf{1} \cos \frac{\phi_1}{2} - i\boldsymbol{\sigma} \cdot \hat{\mathbf{n}}_1 \sin \frac{\phi_1}{2} \right) \\ &= \cos \frac{\phi_1}{2} \cos \frac{\phi_2}{2} - \sin \frac{\phi_1}{2} \sin \frac{\phi_2}{2} (\boldsymbol{\sigma} \cdot \hat{\mathbf{n}}_2) (\boldsymbol{\sigma} \cdot \hat{\mathbf{n}}_1) \\ &\quad - i \sin \frac{\phi_1}{2} \cos \frac{\phi_2}{2} \boldsymbol{\sigma} \cdot \hat{\mathbf{n}}_1 - i \sin \frac{\phi_2}{2} \cos \frac{\phi_1}{2} \boldsymbol{\sigma} \cdot \hat{\mathbf{n}}_2 \\ &= Q - i\boldsymbol{\sigma} \cdot \mathbf{V}, \end{aligned} \quad (14.227)$$

where

$$Q = \cos \frac{\phi_1}{2} \cos \frac{\phi_2}{2} - (\hat{\mathbf{n}}_1 \cdot \hat{\mathbf{n}}_2) \sin \frac{\phi_1}{2} \sin \frac{\phi_2}{2}, \quad (14.228)$$

and

$$\begin{aligned} \mathbf{V} &= \sin \frac{\phi_1}{2} \sin \frac{\phi_2}{2} (\hat{\mathbf{n}}_2 \times \hat{\mathbf{n}}_1) \\ &\quad + \sin \frac{\phi_1}{2} \cos \frac{\phi_2}{2} \hat{\mathbf{n}}_1 + \sin \frac{\phi_2}{2} \cos \frac{\phi_1}{2} \hat{\mathbf{n}}_2. \end{aligned} \quad (14.229)$$

With the help of the identity [see Eq. (15.33)]

$$(\hat{\mathbf{n}}_1 \times \hat{\mathbf{n}}_2) \cdot (\hat{\mathbf{n}}_1 \times \hat{\mathbf{n}}_2) = 1 - (\hat{\mathbf{n}}_1 \cdot \hat{\mathbf{n}}_2)^2, \quad (14.230)$$

one finds that (recall that $\hat{\mathbf{n}}_2 \times \hat{\mathbf{n}}_1$ is perpendicular to both $\hat{\mathbf{n}}_1$ and $\hat{\mathbf{n}}_2$)

$$Q^2 + \mathbf{V} \cdot \mathbf{V} = 1, \quad (14.231)$$

thus [see Eq. (14.94)]

$$J = \mathbf{1} \cos \frac{\phi}{2} - i\boldsymbol{\sigma} \cdot \hat{\mathbf{n}} \sin \frac{\phi}{2} = B(\hat{\mathbf{n}}, \phi), \quad (14.232)$$

where

$$\phi = 2 \tan^{-1} \frac{\sqrt{\mathbf{V} \cdot \mathbf{V}}}{Q}, \quad (14.233)$$

$$\hat{\mathbf{n}} = \frac{\mathbf{V}}{\sqrt{\mathbf{V} \cdot \mathbf{V}}}. \quad (14.234)$$

- b) For the case where $\hat{\mathbf{n}}_1 \cdot \hat{\mathbf{n}}_2 = 0$ one finds that [see Eqs. (14.94) and (6.138) and recall that $\mathbf{A} \times (\mathbf{B} \times \mathbf{C}) = (\mathbf{A} \cdot \mathbf{C}) \mathbf{B} - (\mathbf{A} \cdot \mathbf{B}) \mathbf{C}$]

$$\begin{aligned} J &= \mathbf{1} \cos \frac{\phi_2}{2} - i \boldsymbol{\sigma} \cdot \hat{\mathbf{n}} \sin \frac{\phi_2}{2} \\ &= B(\hat{\mathbf{n}}, \phi_2), \end{aligned} \quad (14.235)$$

where the unit vector $\hat{\mathbf{n}}$ is given by

$$\hat{\mathbf{n}} = \hat{\mathbf{n}}_2 \cos \phi_1 - (\hat{\mathbf{n}}_1 \times \hat{\mathbf{n}}_2) \sin \phi_1. \quad (14.236)$$

- c) For this case [see Eq. (14.94) and note that $(\boldsymbol{\sigma} \cdot \hat{\mathbf{n}}_1)(\boldsymbol{\sigma} \cdot \hat{\mathbf{n}}_1) = \mathbf{1}$]

$$\begin{aligned} J &= (\boldsymbol{\sigma} \cdot \hat{\mathbf{n}}_1) B(\hat{\mathbf{n}}_2, \phi_2) (\boldsymbol{\sigma} \cdot \hat{\mathbf{n}}_1) \\ &= \mathbf{1} \cos \frac{\phi_2}{2} - i (\boldsymbol{\sigma} \cdot \hat{\mathbf{n}}_1) (\boldsymbol{\sigma} \cdot \hat{\mathbf{n}}_2) (\boldsymbol{\sigma} \cdot \hat{\mathbf{n}}_1) \sin \frac{\phi_2}{2}, \end{aligned} \quad (14.237)$$

where [see Eq. (6.138)]

$$\begin{aligned} &(\boldsymbol{\sigma} \cdot \hat{\mathbf{n}}_1) (\boldsymbol{\sigma} \cdot \hat{\mathbf{n}}_2) (\boldsymbol{\sigma} \cdot \hat{\mathbf{n}}_1) \\ &= (\hat{\mathbf{n}}_1 \cdot \hat{\mathbf{n}}_2 + i \boldsymbol{\sigma} \cdot (\hat{\mathbf{n}}_1 \times \hat{\mathbf{n}}_2)) (\boldsymbol{\sigma} \cdot \hat{\mathbf{n}}_1) \\ &= \boldsymbol{\sigma} \cdot \hat{\mathbf{n}}_R, \end{aligned} \quad (14.238)$$

where

$$\hat{\mathbf{n}}_R = (\hat{\mathbf{n}}_1 \cdot \hat{\mathbf{n}}_2) \hat{\mathbf{n}}_1 - (\hat{\mathbf{n}}_1 \times \hat{\mathbf{n}}_2) \times \hat{\mathbf{n}}_1, \quad (14.239)$$

hence

$$J = B(\hat{\mathbf{n}}_R, \phi_2) = B(-\hat{\mathbf{n}}_R, -\phi_2). \quad (14.240)$$

The following holds $\hat{\mathbf{n}}_2 = (\hat{\mathbf{n}}_1 \cdot \hat{\mathbf{n}}_2) \hat{\mathbf{n}}_1 + (\hat{\mathbf{n}}_1 \times \hat{\mathbf{n}}_2) \times \hat{\mathbf{n}}_1$ [recall that $\mathbf{A} \times (\mathbf{B} \times \mathbf{C}) = (\mathbf{A} \cdot \mathbf{C}) \mathbf{B} - (\mathbf{A} \cdot \mathbf{B}) \mathbf{C}$], hence the unit vector $-\hat{\mathbf{n}}_R$ represents a mirror reflection of the vector $\hat{\mathbf{n}}_2$ about a plane perpendicular to $\hat{\mathbf{n}}_1$.

10. The Jones matrix corresponding to reflection is given by

$$J_{\text{FMS}} = J^R J_{\text{CB}}^R J_M J_{\text{CB}} J, \quad (14.241)$$

where $J_{\text{CB}}^R = \sigma_z J_{\text{CB}} \sigma_z$ and $J^R = \sigma_z J \sigma_z$ [see Eq. (14.116)]. For the case where [see Eqs. (14.94) and (14.102)]

$$J_{\text{CB}} = B\left(\hat{\mathbf{y}}, \frac{\pi}{2}\right) = R\left(\frac{\pi}{4}\right),$$

one has [see Eq. (14.110) and recall that $\sigma_z^2 = 1$]

$$J_{\text{FMS}} = \sigma_z J J_{\text{CB}}^2 J, \quad (14.242)$$

or [recall that $J_{\text{CB}}^2 = B(\hat{\mathbf{y}}, \pi) = -i\sigma_y$, $\sigma_y^2 = 1$]

$$J_{\text{FMS}} = -i\sigma_z \sigma_y (\sigma_y J \sigma_y) J, \quad (14.243)$$

or [see Eq. (14.240) and note that $-i\sigma_z \sigma_y = -\sigma_x$ and $B(\hat{\mathbf{n}}, \pi) \doteq -i\boldsymbol{\sigma} \cdot \hat{\mathbf{n}}$]

$$J_{\text{FMS}} = -iB(\hat{\mathbf{x}}, \pi) B(\hat{\mathbf{n}}_{\text{R}}, \phi) B(\hat{\mathbf{n}}, \phi), \quad (14.244)$$

where

$$\hat{\mathbf{n}}_{\text{R}} = (\hat{\mathbf{y}} \cdot \hat{\mathbf{n}}) \hat{\mathbf{y}} - (\hat{\mathbf{y}} \times \hat{\mathbf{n}}) \times \hat{\mathbf{y}}, \quad (14.245)$$

or

$$J_{\text{FMS}} = -iB(\hat{\mathbf{x}}, \pi) B(\mathbf{n}_{\perp} - \mathbf{n}_{\parallel}, -\phi) B(\mathbf{n}_{\perp} + \mathbf{n}_{\parallel}, \phi), \quad (14.246)$$

where

$$\mathbf{n}_{\parallel} = (\hat{\mathbf{y}} \cdot \hat{\mathbf{n}}) \hat{\mathbf{y}}, \quad (14.247)$$

$$\mathbf{n}_{\perp} = (\hat{\mathbf{y}} \times \hat{\mathbf{n}}) \times \hat{\mathbf{y}}. \quad (14.248)$$

With the help of Eq. (14.232) one finds that

$$J_{\text{FMS}} = -\sigma_x B\left(\frac{\mathbf{V}}{\sqrt{1-Q^2}}, 2 \tan^{-1} \frac{\sqrt{1-Q^2}}{Q}\right), \quad (14.249)$$

where

$$\mathbf{V} = 2\left(\mathbf{n}_{\parallel} \cos \frac{\phi}{2} + \mathbf{n}_{\parallel} \times \mathbf{n}_{\perp} \sin \frac{\phi}{2}\right) \sin \frac{\phi}{2}, \quad (14.250)$$

and

$$Q = 1 - 2\mathbf{n}_{\parallel}^2 \sin^2 \frac{\phi}{2}. \quad (14.251)$$

For the case where $\hat{\mathbf{n}} \cdot \hat{\mathbf{y}} = 0$, i.e. when J represents linear birefringence, the result becomes independent on J

$$J_{\text{FMS}} = -iB(\hat{\mathbf{x}}, \pi). \quad (14.252)$$

11. The following holds [see Eq. (14.227)]

$$\begin{aligned} J_{C2}J_{C1} &= Q - i\boldsymbol{\sigma} \cdot \mathbf{V}_+, \\ J_{C1}J_{C2} &= Q - i\boldsymbol{\sigma} \cdot \mathbf{V}_-, \end{aligned}$$

where

$$Q = \cos \frac{\phi_1}{2} \cos \frac{\phi_2}{2} - (\hat{\mathbf{n}}_1 \cdot \hat{\mathbf{n}}_2) \sin \frac{\phi_1}{2} \sin \frac{\phi_2}{2}, \quad (14.253)$$

and

$$\begin{aligned} \mathbf{V}_\pm &= \pm \sin \frac{\phi_1}{2} \sin \frac{\phi_2}{2} (\hat{\mathbf{n}}_2 \times \hat{\mathbf{n}}_1) \\ &\quad + \sin \frac{\phi_1}{2} \cos \frac{\phi_2}{2} \hat{\mathbf{n}}_1 + \sin \frac{\phi_2}{2} \cos \frac{\phi_1}{2} \hat{\mathbf{n}}_2. \end{aligned} \quad (14.254)$$

For the case where both J_1 and J_2 represent colinear birefringence, i.e. when $\hat{\mathbf{n}}_l \cdot \hat{\mathbf{y}} = 0$, the following holds $(\boldsymbol{\sigma} \cdot \hat{\mathbf{n}}_l)^\text{T} = \boldsymbol{\sigma} \cdot \hat{\mathbf{n}}_l$ for $l \in \{1, 2\}$, and $(\boldsymbol{\sigma} \cdot (\hat{\mathbf{n}}_2 \times \hat{\mathbf{n}}_1))^\text{T} = -\boldsymbol{\sigma} \cdot (\hat{\mathbf{n}}_2 \times \hat{\mathbf{n}}_1)$ [see Eq. (14.111), and note that $\hat{\mathbf{n}}_2 \times \hat{\mathbf{n}}_1$ is parallel to $\hat{\mathbf{y}}$], hence $J_1 J_2 = (J_2 J_1)^\text{T}$.

15. Light Matter Interaction

In this chapter the transitions between atomic states that result from interaction with an electromagnetic (EM) field are discussed.

15.1 Hamiltonian

Consider an atom in an EM field. The classical Hamiltonian \mathcal{H}_F of the EM field is given by Eq. (14.52). For the case of hydrogen, and in the absence of EM field, the Hamiltonian of the atom is given by Eq. (7.2). In general, the classical Hamiltonian of a point particle having charge e and mass m_e in an EM field having scalar potential φ and vector potential \mathbf{A} is given by Eq. (1.62). In the Coulomb gauge the vector potential \mathbf{A} is chosen such that $\nabla \cdot \mathbf{A} = 0$, and the scalar potential φ vanishes provided that no sources (charge and current) are present. The EM field is assumed to be sufficiently small to allow employing the following approximation

$$\left(\mathbf{p} - \frac{e}{c}\mathbf{A}\right)^2 \simeq \mathbf{p}^2 - 2\frac{e}{c}\mathbf{A} \cdot \mathbf{p}, \quad (15.1)$$

where \mathbf{p} is the momentum vector. Recall that in the Coulomb gauge the vector operators \mathbf{p} and \mathbf{A} satisfy the relation $\mathbf{p} \cdot \mathbf{A} = \mathbf{A} \cdot \mathbf{p}$, as can be seen from Eqs. (6.219) and (6.571). These results and approximation allow expressing the Hamiltonian of the system as

$$\mathcal{H} = \mathcal{H}_0 + \mathcal{H}_F + \mathcal{H}_p, \quad (15.2)$$

where \mathcal{H}_0 is the Hamiltonian of the atom in the absence of EM field, and where \mathcal{H}_p , which is given by

$$\mathcal{H}_p = -\frac{e}{m_e c}\mathbf{A} \cdot \mathbf{p}, \quad (15.3)$$

is the coupling Hamiltonian between the atom and the EM field.

The quantum Hamiltonian \mathcal{H}_F of the EM field is given by Eq. (14.72)

$$\mathcal{H}_F = \sum_{\mathbf{k}, \lambda} \hbar \omega_{\mathbf{k}} \left(a_{\mathbf{k}, \lambda}^\dagger a_{\mathbf{k}, \lambda} + \frac{1}{2} \right), \quad (15.4)$$

and the vector potential \mathbf{A} is given by Eq. (14.73)

$$\mathbf{A}(\mathbf{r}, t) = \sum_{\mathbf{k}, \lambda} \sqrt{\frac{2\pi c^2 \hbar}{\omega_{\mathbf{k}} V}} \left(\hat{\mathbf{e}}_{\mathbf{k}, \lambda} e^{i(\mathbf{k} \cdot \mathbf{r} - \omega_{\mathbf{k}} t)} a_{\mathbf{k}, \lambda} + \hat{\mathbf{e}}_{\mathbf{k}, \lambda}^* e^{-i(\mathbf{k} \cdot \mathbf{r} - \omega_{\mathbf{k}} t)} a_{\mathbf{k}, \lambda}^\dagger \right). \quad (15.5)$$

15.2 Transition Rates

While the Hamiltonian \mathcal{H}_p is considered as a perturbation, the unperturbed Hamiltonian is taken to be $\mathcal{H}_0 + \mathcal{H}_F$. The eigenvectors of $\mathcal{H}_0 + \mathcal{H}_F$ are labeled as $|\{s_{\mathbf{k}, \lambda}\}, \eta\rangle$. While the integers $s_{\mathbf{k}, \lambda}$ represent the number of photons occupying each of the modes of the EM field, the index η labels the atomic energy eigenstate. The following holds

$$\mathcal{H}_0 |\{s_{\mathbf{k}, \lambda}\}, \eta\rangle = E_\eta |\{s_{\mathbf{k}, \lambda}\}, \eta\rangle,$$

where E_η is the energy of the atomic state, and

$$\mathcal{H}_F |\{s_{\mathbf{k}, \lambda}\}, \eta\rangle = \sum_{\mathbf{k}, \lambda} \hbar \omega_{\mathbf{k}} \left(s_{\mathbf{k}, \lambda} + \frac{1}{2} \right) |\{s_{\mathbf{k}, \lambda}\}, \eta\rangle. \quad (15.6)$$

15.2.1 Spontaneous Emission

Consider the case where the system is initially in a state $|i\rangle = |\{s_{\mathbf{k}, \lambda} = 0\}, \eta_i\rangle$, for which all photon occupation numbers are zero, and the atomic state is labeled by the index η_i . The final state is taken to be $|f\rangle = a_{\mathbf{k}, \lambda}^\dagger |\{s_{\mathbf{k}, \lambda} = 0\}, \eta_f\rangle$, for which one photon is created in mode \mathbf{k}, λ , and the atomic state is labeled by the index η_f . To lowest nonvanishing order in perturbation theory the transition rate $w_{i,f}$ is given by Eq. (10.35)

$$w_{i,f} = \frac{2\pi}{\hbar^2} \delta(\omega_{\mathbf{k}} - \omega_{i,f}) |\langle f | \mathcal{H}_p | i \rangle|^2, \quad (15.7)$$

where $\omega_{i,f} = (E_{\eta_i} - E_{\eta_f})/\hbar$. With the help of Eqs. (14.73) and (15.3) $w_{i,f}$ can be rewritten as

$$w_{i,f} = \left(\frac{e}{m_e c} \right)^2 \frac{4\pi^2 c^2}{\hbar \omega_{\mathbf{k}} V} \delta(\omega_{\mathbf{k}} - \omega_{i,f}) \left| \langle f | \hat{\mathbf{e}}_{\mathbf{k}, \lambda}^* \cdot \mathbf{p} e^{-i\mathbf{k} \cdot \mathbf{r}} a_{\mathbf{k}, \lambda}^\dagger | i \rangle \right|^2. \quad (15.8)$$

As can be seen from Eq. (7.2), the following holds

$$[\mathcal{H}_0, \mathbf{r}] = \frac{1}{m_e} (-i\hbar) \mathbf{p}, \quad (15.9)$$

thus

$$\begin{aligned}
 w_{i,f} &= \frac{4\pi^2 e^2 \omega_{\mathbf{k}}}{\hbar V} \delta(\omega_{\mathbf{k}} - \omega_{i,f}) \left| \langle f | \hat{\mathbf{e}}_{\mathbf{k},\lambda}^* \cdot \mathbf{r} e^{-i\mathbf{k}\cdot\mathbf{r}} a_{\mathbf{k},\lambda}^\dagger | i \rangle \right|^2 \\
 &= \frac{4\pi^2 e^2 \omega_{\mathbf{k}}}{\hbar V} \delta(\omega_{\mathbf{k}} - \omega_{i,f}) |M_{i,f}|^2,
 \end{aligned} \tag{15.10}$$

where the atomic matrix element $M_{i,f}$ is given by

$$M_{i,f} = \langle \eta_f | \hat{\mathbf{e}}_{\mathbf{k},\lambda}^* \cdot \mathbf{r} e^{-i\mathbf{k}\cdot\mathbf{r}} | \eta_i \rangle. \tag{15.11}$$

15.2.2 Stimulated Emission and Absorption

The process of spontaneous emission of a photon in mode \mathbf{k}, λ can be labeled as $(i, s_{\mathbf{k},\lambda}) \rightarrow (f, s_{\mathbf{k},\lambda} + 1)$, where $s_{\mathbf{k},\lambda} = 0$. In the case of stimulated emission, on the other hand, the initial photon occupation is assumed to be nonzero, i.e. $s_{\mathbf{k},\lambda} \geq 1$. Let $w_{(i, s_{\mathbf{k},\lambda}) \rightarrow (f, s_{\mathbf{k},\lambda} + 1), \lambda}^{(e)}$ be the rate of emission of photons in mode \mathbf{k}, λ , given that the initial photon occupation number is $s_{\mathbf{k},\lambda}$. With the help of Eq. (14.70) the expression for the case of spontaneous emission (15.10) can be easily generalized for arbitrary initial photon occupation $s_{\mathbf{k},\lambda}$

$$w_{(i, s_{\mathbf{k},\lambda}) \rightarrow (f, s_{\mathbf{k},\lambda} + 1), \lambda}^{(e)} = \frac{4\pi^2 e^2 \omega_{\mathbf{k}} (s_{\mathbf{k},\lambda} + 1)}{\hbar V} \delta(\omega_{\mathbf{k}} - \omega_{i,f}) |M_{i,f}|^2. \tag{15.12}$$

Note that for the case of emission it is assumed that the energy of the atomic state i is larger than the energy of the atomic state f , i.e. $\omega_{i,f} = (E_{\eta_i} - E_{\eta_f})/\hbar > 0$.

Absorption is the reverse process. Let $w_{(i, s_{\mathbf{k},\lambda}) \rightarrow (f, s_{\mathbf{k},\lambda} - 1), \lambda}^{(a)}$ be the rate of absorption of photons in mode \mathbf{k}, λ , given that the initial photon occupation number is $s_{\mathbf{k},\lambda}$. With the help of Eq. (14.69) one finds using a derivation similar to the one that was used above to obtain Eq. (15.12) that

$$w_{(i, s_{\mathbf{k},\lambda}) \rightarrow (f, s_{\mathbf{k},\lambda} - 1), \lambda}^{(a)} = \frac{4\pi^2 e^2 \omega_{\mathbf{k}} s_{\mathbf{k},\lambda}}{\hbar V} \delta(\omega_{\mathbf{k}} + \omega_{i,f}) |M_{i,f}|^2. \tag{15.13}$$

Note that in this case it is assumed that $\omega_{i,f} < 0$.

The emission (15.12) and absorption (15.13) rates provide the contribution of a single mode of the EM field. Let $d\Gamma_{(i,s) \rightarrow (f,s+1), \lambda}^{(e)}/d\Omega$ ($d\Gamma_{(i,s) \rightarrow (f,s-1), \lambda}^{(a)}/d\Omega$) be the total emitted (absorbed) rate in the infinitesimal solid angle $d\Omega$ having polarization λ . For both cases s denotes the photon occupation number of the initial state. To calculate these rates the contributions from all modes in the EM field should be added. In the limit of large volume the discrete sum over wave vectors \mathbf{k} can be replaced by an integral according to Eq. (14.74). By using the relation $\omega_{\mathbf{k}} = ck$, where $k = |\mathbf{k}|$, one finds that

$$\begin{aligned}
 \frac{d\Gamma_{(i,s)\rightarrow(f,s+1),\lambda}^{(e)}}{d\Omega} &= \frac{V}{(2\pi)^3} \int_0^\infty dk k^2 w_{(i,s_{\mathbf{k},\lambda})\rightarrow(f,s_{\mathbf{k},\lambda+1}),\lambda}^{(e)} \\
 &= \frac{e^2 (s+1)}{2\pi\hbar c^3} |M_{i,f}|^2 \int_0^\infty dx x^3 \delta(x - \omega_{i,f}) \\
 &= \frac{\alpha_{\text{fs}} (s+1) \omega_{i,f}^3}{2\pi c^2} |M_{i,f}|^2 ,
 \end{aligned} \tag{15.14}$$

where

$$\alpha_{\text{fs}} = \frac{e^2}{\hbar c} \simeq \frac{1}{137} , \tag{15.15}$$

is the fine-structure constant. In a similar way, one finds for the case of absorption that

$$\frac{d\Gamma_{(i,s)\rightarrow(f,s+1),\lambda}^{(a)}}{d\Omega} = \frac{\alpha_{\text{fs}} s \omega_{i,f}^3}{2\pi c^2} |M_{i,f}|^2 . \tag{15.16}$$

15.2.3 Selection Rules

While the size of an atom a_{atom} is on the order of the Bohr's radius $a_0 = 0.53 \times 10^{-10} \text{ m}$ (7.64), the energy difference $E_{\eta_i} - E_{\eta_f}$ is expected to be on the order of the ionization energy of hydrogen atom $E_I = 13.6 \text{ eV}$ (7.66). Using the relation $\omega_{\mathbf{k}} = (E_{\eta_i} - E_{\eta_f}) / \hbar = ck$ one finds that [see Eq. (15.15)]

$$a_{\text{atom}} k \simeq \frac{a_0 E_I}{c\hbar} = \frac{\alpha_{\text{fs}}}{2} = 3.6 \times 10^{-3} . \tag{15.17}$$

Thus, to a good approximation the term $e^{-i\mathbf{k}\cdot\mathbf{r}}$ in the expression for the matrix element $M_{i,f}$ can be replaced by unity

$$M_{i,f} \simeq \langle \eta_f | \hat{\boldsymbol{\epsilon}}_{\mathbf{k},\lambda}^* \cdot \mathbf{r} | \eta_i \rangle . \tag{15.18}$$

This approximation is called the dipole approximation.

The atomic energy eigenstates $|\eta\rangle$ can be chosen to be also eigenvectors of the angular momentum operators L_z and \mathbf{L}^2 . It is convenient to employ the notation $|k, l, m, \sigma\rangle$ to label these states, where k, l and m are orbital quantum numbers and where σ labels the spin state. As can be seen from Eqs. (7.42), (7.43) and (7.44) the following holds

$$\mathcal{H}_0 |k, l, m, \sigma\rangle = E_{kl} |k, l, m, \sigma\rangle , \tag{15.19}$$

$$\mathbf{L}^2 |k, l, m, \sigma\rangle = l(l+1) \hbar^2 |k, l, m, \sigma\rangle , \tag{15.20}$$

$$L_z |k, l, m, \sigma\rangle = m\hbar |k, l, m, \sigma\rangle . \tag{15.21}$$

Since it is assumed that no magnetic field is externally applied, the eigenenergies E_{kl} are taken to be independent on the quantum numbers m and σ .

Radiation transitions between a pair of states $|k_i, l_i, m_i, \sigma_i\rangle$ and $|k_f, l_f, m_f, \sigma_f\rangle$ can occur only when the corresponding matrix element (15.18) is nonzero. This requirement yields some conditions known as selection rules. The first one refers to the spin quantum number σ . Note that $M_{i,f}$ is a matrix element of an orbital operator (15.18), and consequently it vanishes unless $\sigma_f = \sigma_i$, or alternatively, unless $\Delta\sigma = \sigma_f - \sigma_i = 0$. It is important to keep in mind that this selection rule is valid only when spin-orbit interaction can be neglected.

Exercise 15.2.1. Show that the selection rule for the magnetic quantum number m is given by

$$\Delta m = m_f - m_i \in \{-1, 0, 1\} . \quad (15.22)$$

Solution 15.2.1. Using the relations $L_z = xp_y - yp_x$ and $[x_i, p_j] = i\hbar\delta_{ij}$ it is easy to show that $[L_z, z] = 0$ and $[L_z, x \pm iy] = \pm\hbar(x \pm iy)$. The first relation together with Eq. (15.21) imply that

$$\begin{aligned} 0 &= \langle k_f, l_f, m_f, \sigma_f | [L_z, z] | k_i, l_i, m_i, \sigma_i \rangle \\ &= \hbar(m_f - m_i) \langle k_f, l_f, m_f, \sigma_f | z | k_i, l_i, m_i, \sigma_i \rangle , \end{aligned} \quad (15.23)$$

whereas the second relation together with Eq. (15.21) imply that

$$\begin{aligned} &\langle k_f, l_f, m_f, \sigma_f | [L_z, x \pm iy] | k_i, l_i, m_i, \sigma_i \rangle \\ &= \hbar(m_f - m_i) \langle k_f, l_f, m_f, \sigma_f | x \pm iy | k_i, l_i, m_i, \sigma_i \rangle \\ &= \pm\hbar \langle k_f, l_f, m_f, \sigma_f | (x \pm iy) | k_i, l_i, m_i, \sigma_i \rangle , \end{aligned} \quad (15.24)$$

thus

$$\hbar(m_f - m_i \mp 1) \langle k_f, l_f, m_f, \sigma_f | x \pm iy | k_i, l_i, m_i, \sigma_i \rangle = 0 . \quad (15.25)$$

Therefore $M_{i,f} = 0$ [see Eq. (15.18)] unless $\Delta m \in \{-1, 0, 1\}$. The transition $\Delta m = 0$ is associated with colinear polarization in the z direction, whereas the transitions $\Delta m = \pm 1$ are associated with clockwise and counterclockwise circular polarizations respectively.

Exercise 15.2.2. Show that the selection rule for the quantum number l is given by

$$\Delta l = l_f - l_i \in \{-1, 1\} . \quad (15.26)$$

Solution 15.2.2. Using Eq. (15.53), which is given by $[\mathbf{L}^2, [\mathbf{L}^2, \mathbf{r}]] = 2\hbar^2(\mathbf{r}\mathbf{L}^2 + \mathbf{L}^2\mathbf{r})$, together with Eq. (15.20) yield

$$\begin{aligned} &\langle k_f, l_f, m_f, \sigma_f | [\mathbf{L}^2, [\mathbf{L}^2, \mathbf{r}]] | k_i, l_i, m_i, \sigma_i \rangle \\ &= 2\hbar^4 (l_f(l_f + 1) + l_i(l_i + 1)) \langle k_f, l_f, m_f, \sigma_f | \mathbf{r} | k_i, l_i, m_i, \sigma_i \rangle \\ &= \hbar^4 (l_f(l_f + 1) - l_i(l_i + 1))^2 \langle k_f, l_f, m_f, \sigma_f | \mathbf{r} | k_i, l_i, m_i, \sigma_i \rangle , \end{aligned} \quad (15.27)$$

thus with the help of the identity

$$\begin{aligned} & (l_f (l_f + 1) - l_i (l_i + 1))^2 - 2(l_f (l_f + 1) + l_i (l_i + 1)) \\ &= (l_i + l_f) (l_i + l_f + 2) \left[(l_i - l_f)^2 - 1 \right] , \end{aligned} \quad (15.28)$$

one finds that

$$(l_i + l_f) (l_i + l_f + 2) \left[(l_i - l_f)^2 - 1 \right] \langle k_f, l_f, m_f, \sigma_f | \mathbf{r} | k_i, l_i, m_i, \sigma_i \rangle = 0 . \quad (15.29)$$

Since both l_i and l_f are non negative integers, and consequently $l_i + l_f + 2 > 0$, one finds that $\langle k_f, l_f, m_f, \sigma_f | \mathbf{r} | k_i, l_i, m_i, \sigma_i \rangle$ can be nonzero only when $l_i = l_f = 0$ or $|\Delta l| = 1$. However, for the first possibility, for which $l_i = m_i = l_f = m_f = 0$, the wavefunctions of both states $|k_i, l_i, m_i, \sigma_i\rangle$ and $|k_f, l_f, m_f, \sigma_f\rangle$ is a function of the radial coordinate r only [see Eq. (6.130)], and consequently $\langle k_f, l_f, m_f, \sigma_f | \mathbf{r} | k_i, l_i, m_i, \sigma_i \rangle = 0$. Therefore the selection rule is given by $\Delta l \in \{-1, 1\}$. Note that a selection rule similar to (15.26) can be obtained from parity conservation [see Eq. (14.209)].

15.3 Semiclassical Case

Consider the case where one mode of the EM field, which has angular frequency ω and polarization vector $\hat{\mathbf{e}}$, is externally driven to a coherent state $|\alpha\rangle$, where $|\alpha| \gg 1$. In the semiclassical approximation the annihilation operator of the driven mode a is substituted by the complex constant α (and the operator a^\dagger by α^*). Furthermore, all other modes are disregarded. According to this approach $\mathbf{A}(\mathbf{r}, t)$ is taken to be given by [see Eq. (15.5)]

$$\mathbf{A}(\mathbf{r}, t) = \sqrt{\frac{2\pi c^2 \hbar}{\omega V}} \left(\hat{\mathbf{e}} e^{i(\mathbf{k}\cdot\mathbf{r} - \omega t)} \alpha + \hat{\mathbf{e}}^* e^{-i(\mathbf{k}\cdot\mathbf{r} - \omega t)} \alpha^* \right) . \quad (15.30)$$

Exercise 15.3.1. Calculate the energy U_F of an EM field having vector potential given by Eq. (15.30).

Solution 15.3.1. With the help of Eqs. (14.6), (14.7), (14.41), (14.42), (14.55) and the general vector identity

$$\nabla \times (f \mathbf{V}) = f \nabla \times \mathbf{V} + (\nabla f) \times \mathbf{V} , \quad (15.31)$$

one finds that

$$\begin{aligned} U_F &= \frac{1}{8\pi} \int_V \left(-\frac{1}{c} \frac{\partial \mathbf{A}}{\partial t} \right)^2 dV + \frac{1}{8\pi} \int_V (\nabla \times \mathbf{A})^2 dV \\ &= \frac{\hbar\omega}{4V} \int_V \left(i \hat{\mathbf{e}} e^{i(\mathbf{k}\cdot\mathbf{r} - \omega t)} \alpha - i \hat{\mathbf{e}}^* e^{-i(\mathbf{k}\cdot\mathbf{r} - \omega t)} \alpha^* \right)^2 dV \\ &\quad + \frac{\hbar\omega}{4V} \int_V \left(i \frac{\mathbf{k} \times \hat{\mathbf{e}}}{|\mathbf{k}|} e^{i(\mathbf{k}\cdot\mathbf{r} - \omega t)} \alpha - i \frac{\mathbf{k} \times \hat{\mathbf{e}}^*}{|\mathbf{k}|} e^{-i(\mathbf{k}\cdot\mathbf{r} - \omega t)} \alpha^* \right)^2 dV . \end{aligned} \quad (15.32)$$

With the help of the general vector identity

$$(\mathbf{V}_1 \times \mathbf{V}_2) \cdot (\mathbf{V}_3 \times \mathbf{V}_4) = (\mathbf{V}_1 \cdot \mathbf{V}_3)(\mathbf{V}_2 \cdot \mathbf{V}_4) - (\mathbf{V}_1 \cdot \mathbf{V}_4)(\mathbf{V}_2 \cdot \mathbf{V}_3) , \quad (15.33)$$

and Eq. (14.84) one obtains

$$\hat{\boldsymbol{\epsilon}} \cdot \hat{\boldsymbol{\epsilon}}^* = 1 , \quad (15.34)$$

and

$$\frac{\mathbf{k} \times \hat{\boldsymbol{\epsilon}}}{|\mathbf{k}|} \cdot \frac{\mathbf{k} \times \hat{\boldsymbol{\epsilon}}^*}{|\mathbf{k}|} = 1 , \quad (15.35)$$

and thus

$$U_F = \hbar\omega |\alpha|^2 . \quad (15.36)$$

Exercise 15.3.2. Calculate the Poynting vector \mathbf{S} , which is defined by

$$\mathbf{S} = \frac{c}{4\pi} \mathbf{E} \times \mathbf{B} , \quad (15.37)$$

of an EM field having vector potential given by Eq. (15.30).

Solution 15.3.2. With the help of Eqs. (14.6) and (14.7) one obtains [see Eq. (14.88)]

$$\begin{aligned} \mathbf{S} &= -\frac{1}{4\pi} \left(\frac{\partial \mathbf{A}}{\partial t} \right) \times (\nabla \times \mathbf{A}) \\ &= \frac{c\hbar\omega}{2V} \left(i\hat{\boldsymbol{\epsilon}} e^{i(\mathbf{k}\cdot\mathbf{r}-\omega t)} \alpha - i\hat{\boldsymbol{\epsilon}}^* e^{-i(\mathbf{k}\cdot\mathbf{r}-\omega t)} \alpha^* \right) \\ &\quad \times \left(i \frac{\mathbf{k} \times \hat{\boldsymbol{\epsilon}}}{|\mathbf{k}|} e^{i(\mathbf{k}\cdot\mathbf{r}-\omega t)} \alpha - i \frac{\mathbf{k} \times \hat{\boldsymbol{\epsilon}}^*}{|\mathbf{k}|} e^{-i(\mathbf{k}\cdot\mathbf{r}-\omega t)} \alpha^* \right) \\ &= \frac{c\hbar\omega}{V} \left[\frac{\mathbf{k}}{|\mathbf{k}|} |\alpha|^2 + \text{Re} \left(\frac{\hat{\boldsymbol{\epsilon}} \times (\mathbf{k} \times \hat{\boldsymbol{\epsilon}}) (i\alpha e^{i(\mathbf{k}\cdot\mathbf{r}-\omega t)})^2}{|\mathbf{k}|} \right) \right] . \end{aligned} \quad (15.38)$$

The average Poynting vector over time $\langle \mathbf{S} \rangle$ is given by [see Eq. (15.36)]

$$\langle \mathbf{S} \rangle = \frac{c\hbar\omega |\alpha|^2}{V} \frac{\mathbf{k}}{|\mathbf{k}|} = \frac{cU_F}{V} \frac{\mathbf{k}}{|\mathbf{k}|} . \quad (15.39)$$

When ω is close to a specific transition frequency $\omega_a = (E_+ - E_-)/\hbar$ between two atomic states, which are labeled by $|+\rangle$ and $|-\rangle$, the atom can be approximately considered to be a two level system. In the dipole approximation the matrix element $\langle + | \mathcal{H}_p | - \rangle$ is given by [see Eqs. (15.3), (15.9) and (15.18)]

$$\begin{aligned}
 \langle + | \mathcal{H}_p | - \rangle &= -\frac{i e \omega_a}{c} \langle + | \mathbf{A} \cdot \mathbf{r} | - \rangle \\
 &= \frac{\hbar}{2} (\Omega e^{-i\omega t} + \Omega^* e^{i\omega t}) ,
 \end{aligned} \tag{15.40}$$

where (it is assumed that $\omega \simeq \omega_a$)

$$\Omega = -2ie d_p \sqrt{\frac{2\pi\omega_a}{\hbar V}} \alpha , \tag{15.41}$$

where

$$d_p = \hat{\mathbf{e}} \cdot \langle + | \mathbf{r} | - \rangle . \tag{15.42}$$

It is convenient to express the complex frequency Ω as $\Omega = \omega_1 e^{-i\theta_1}$, where both ω_1 and θ_1 are real, and where [see Eq. (15.39)]

$$\omega_1 = 2e |d_p| \sqrt{\frac{2\pi\omega_a |\alpha|^2}{\hbar V}} = \frac{2e |d_p|}{\hbar} \sqrt{\frac{2\pi}{c}} \langle |\mathbf{S}| \rangle . \tag{15.43}$$

Due to selection rules the diagonal matrix elements of \mathcal{H}_p vanish.

The Schrödinger equation is given by

$$i\hbar \frac{d}{dt} |\psi\rangle = \mathcal{H} |\psi\rangle , \tag{15.44}$$

where the matrix representation in the basis $\{|+\rangle, |-\rangle\}$ of the Hamiltonian \mathcal{H} is given by [see Eq. (15.40)]

$$\mathcal{H} = \frac{\hbar}{2} \begin{pmatrix} \omega_a & \omega_1 (e^{-i(\omega t + \theta_1)} + e^{i(\omega t + \theta_1)}) \\ \omega_1 (e^{i(\omega t + \theta_1)} + e^{-i(\omega t + \theta_1)}) & -\omega_a \end{pmatrix} . \tag{15.45}$$

It is convenient to express the general solution as

$$|\psi(t)\rangle = b_+(t) \exp\left(-\frac{i\omega t}{2}\right) |+\rangle + b_-(t) \exp\left(\frac{i\omega t}{2}\right) |-\rangle . \tag{15.46}$$

Substituting into the Schrödinger equation yields [see Eq. (6.377)]

$$i \frac{d}{dt} \begin{pmatrix} b_+ \\ b_- \end{pmatrix} = \frac{1}{2} \begin{pmatrix} \Delta_\omega & \omega_1 (e^{-i\theta_1} + e^{i(2\omega t + \theta_1)}) \\ \omega_1 (e^{i\theta_1} + e^{-i(2\omega t + \theta_1)}) & -\Delta_\omega \end{pmatrix} \begin{pmatrix} b_+ \\ b_- \end{pmatrix} , \tag{15.47}$$

where

$$\Delta_\omega = \omega_a - \omega . \tag{15.48}$$

In the rotating wave approximation the rapidly oscillating terms $e^{\pm i(2\omega t + \theta_1)}$ are disregarded, since their influence in the long time limit is typically negligible. This approximation is equivalent to the assumption that the second term in Eq. (15.40) can be disregarded. Furthermore, the phase factor θ_1 can be eliminated by resetting the time zero point accordingly. Thus, the Hamiltonian can be taken to be given by

$$\mathcal{H} \doteq \frac{\hbar}{2} \begin{pmatrix} \omega_a & \omega_1 e^{-i\omega t} \\ \omega_1 e^{i\omega t} & -\omega_a \end{pmatrix}, \quad (15.49)$$

and the equation of motion in the rotating frame can be taken to be given by

$$i \frac{d}{dt} \begin{pmatrix} b_+ \\ b_- \end{pmatrix} = \frac{1}{2} \begin{pmatrix} \Delta_\omega & \omega_1 \\ \omega_1 & -\Delta_\omega \end{pmatrix} \begin{pmatrix} b_+ \\ b_- \end{pmatrix}. \quad (15.50)$$

The time evolution is found using Eq. (6.139) [see also Eq. (6.381)]

$$\begin{aligned} & \begin{pmatrix} b_+(t) \\ b_-(t) \end{pmatrix} \\ &= \begin{pmatrix} \cos \theta - i \frac{\Delta_\omega \sin \theta}{\sqrt{\omega_1^2 + \Delta_\omega^2}} & -i \frac{\omega_1 \sin \theta}{\sqrt{\omega_1^2 + \Delta_\omega^2}} \\ -i \frac{\omega_1 \sin \theta}{\sqrt{\omega_1^2 + \Delta_\omega^2}} & \cos \theta + i \frac{\Delta_\omega \sin \theta}{\sqrt{\omega_1^2 + \Delta_\omega^2}} \end{pmatrix} \begin{pmatrix} b_+(0) \\ b_-(0) \end{pmatrix}, \end{aligned} \quad (15.51)$$

where

$$\theta = \frac{\sqrt{\omega_1^2 + \Delta_\omega^2} t}{2}. \quad (15.52)$$

15.4 Problems

1. Show that

$$[\mathbf{L}^2, [\mathbf{L}^2, \mathbf{r}]] = 2\hbar^2 (\mathbf{r}\mathbf{L}^2 + \mathbf{L}^2\mathbf{r}). \quad (15.53)$$

2. Consider an atom having a set of orthonormal energy eigenstates $\{|\eta_n\rangle\}$. The oscillator strength f_{nm} associated with the transition between state $|\eta_n\rangle$ to state $|\eta_m\rangle$ is defined by

$$f_{nm} = \frac{2m_e\omega_{n,m}}{3\hbar} |\langle \eta_f | \mathbf{r} | \eta_i \rangle|^2. \quad (15.54)$$

Show that

$$\sum_{n'} f_{n,n'} = 1. \quad (15.55)$$

3. Consider a point particle having charge q and mass m in a 3D harmonic potential given by

$$V(x, y, z) = \frac{1}{2}m\omega_0^2 r^2, \quad (15.56)$$

where $r = \sqrt{x^2 + y^2 + z^2}$ is the radial coordinate and ω_0 is a positive constant. Calculate to lowest nonvanishing order in perturbation theory the transition rate from the ground state induced by applying a magnetic field given by $\mathbf{B} = B\hat{\mathbf{z}} \cos(\omega t)$, where B and ω are both positive constants and $\hat{\mathbf{z}}$ is a unit vector in the z direction.

4. Calculate the lifetime of hydrogen atom
- states having principle quantum number $n = 2$.
 - state $n = 3$ and $l = 0$.
5. Consider a point particle having charge q and mass m in a 3D harmonic potential given by

$$V(x, y, z) = \frac{1}{2}m\omega_0^2 r^2, \quad (15.57)$$

where $r = \sqrt{x^2 + y^2 + z^2}$ is the radial coordinate and ω_0 is a positive constant. Calculate the lifetime Γ^{-1} of the first excited level in the dipole approximation.

6. Consider a hydrogen atom that is initially at time $t \rightarrow -\infty$ in its ground state. An electric field in the z direction given by

$$\mathbf{E}(t) = E_0\hat{\mathbf{z}} \frac{\tau^2}{\tau^2 + t^2}, \quad (15.58)$$

where τ is a constant having the dimension of time, is externally applied. Calculate the probability p_{2p} to find the atom in the sub-shell $2p$ at time $t \rightarrow \infty$.

7. Consider a particle having mass m and charge q moving in a one-dimensional harmonic oscillator having angular resonance frequency ω . Calculate using the dipole approximation the rate of spontaneous emission from the number state $|n\rangle$ to the ground state $|0\rangle$.
8. A hydrogen atom is initially in its ground state. An electric field given by $E_0 \cos(\omega t)$, where both E_0 and ω are constants, is externally applied. Assume that $\hbar\omega > E_I$, where E_I is the ionization energy of the atom. Calculate the rate of ionization.
9. **Einstein's A and B coefficients** - Consider an ensemble of two level atoms. The population of atoms in the ground and in the excited state are denoted by N_1 and N_2 , respectively. The energy of the excited state is $\epsilon = \hbar\omega_0$ above the ground state. The ensemble is in thermal equilibrium with electromagnetic field at temperature T . Absorption of a photon having angular frequency ω_0 gives rise to transition from the ground to

the excited state, whereas emission is the opposite process of a photon creation and a decay from the excited to the ground state. When no photons having angular frequency ω_0 are present in the initial state the emission is called spontaneous, whereas stimulated emission occurs when this electromagnetic mode is initially occupied. Let $\rho_0 d\omega$ be the averaged electromagnetic energy per unit volume in a frequency band $d\omega$ centered at ω_0 . The coefficient ρ_0 is expressed as a function of T and ω using the Planck's radiation law. In Einstein's notation the rate of absorption is denoted by $B_{12}N_1\rho_0$, the rate of stimulated emission by $B_{21}N_2\rho_0$, and the rate of spontaneous emission by $A_{21}N_2$. The coefficients B_{12} , B_{21} and A_{21} are assumed to be all temperature independent (explain why). Calculate the ratios B_{12}/B_{21} and A_{21}/B_{21} , and express the results as a function of T and ϵ .

10. **Dipole spontaneous emission** - Consider a particle having charge e confined to a thin spherical shell of radius r_0 . The Hamiltonian is given by

$$\mathcal{H} = \frac{\mathbf{L}^2}{2I}, \quad (15.59)$$

where \mathbf{L} is the vector angular momentum operator, and I is a real constant (moment of inertia). Employ the dipole approximation to estimate the rate w of spontaneous emission from the first excited energy level. Express your result in terms of the electric dipole moment $d = er_0$ and the angular frequency ω of emitted radiation.

11. **Spin flip** - Consider a neutral spin 1/2 particle having magnetic moment μ in a constant magnetic field $\mathbf{H}_0 = -H_0\hat{\mathbf{z}}$. The spin is initially in its excited state $|+\rangle$. Find the rate $\Gamma^{(\text{se})}$ of spontaneous emission (i.e. rate of spin transition to its ground state $|-\rangle$).

15.5 Solutions

1. Using the relations $[L_x, z] = -i\hbar y$, $[L_y, z] = i\hbar x$ and $[L_z, z] = 0$ one finds that

$$\begin{aligned} [\mathbf{L}^2, z] &= [L_x^2, z] + [L_y^2, z] \\ &= i\hbar(-L_x y - y L_x + L_y x + x L_y) \\ &= i\hbar \mathbf{V} \cdot \hat{\mathbf{z}}, \end{aligned} \quad (15.60)$$

where $\mathbf{V} = \mathbf{r} \times \mathbf{L} - \mathbf{L} \times \mathbf{r}$. Thus the following holds $[\mathbf{L}^2, \mathbf{r}] = i\hbar \mathbf{V}$. With the help of the identities

$$\begin{aligned} [L_x, V_z] &= -L_x [L_x, y] - [L_x, y] L_x + [L_x, L_y] x + x [L_x, L_y] = -i\hbar V_y, \\ [L_y, V_z] &= -[L_y, L_x] y - y [L_y, L_x] + L_y [L_y, x] + [L_y, x] L_y = i\hbar V_x, \\ [L_z, V_z] &= -[L_z, L_x y] - [L_z, y L_x] + [L_z, L_y x] + [L_z, x L_y] = 0, \end{aligned}$$

one finds that

$$\begin{aligned}
 [\mathbf{L}^2, [\mathbf{L}^2, z]] &= i\hbar [\mathbf{L}^2, V_z] \\
 &= \hbar^2 (L_x V_y + V_y L_x - L_y V_x - V_x L_y) \\
 &= \hbar^2 (\mathbf{L} \times \mathbf{V} - \mathbf{V} \times \mathbf{L}) \cdot \hat{\mathbf{z}},
 \end{aligned} \tag{15.61}$$

thus

$$\begin{aligned}
 [\mathbf{L}^2, [\mathbf{L}^2, \mathbf{r}]] &= \hbar^2 (\mathbf{L} \times \mathbf{V} - \mathbf{V} \times \mathbf{L}) \\
 &= \hbar^2 (\mathbf{L} \times (\mathbf{r} \times \mathbf{L}) - \mathbf{L} \times (\mathbf{L} \times \mathbf{r}) - (\mathbf{r} \times \mathbf{L}) \times \mathbf{L} + (\mathbf{L} \times \mathbf{r}) \times \mathbf{L}) \\
 &= 2\hbar^2 (\mathbf{rL}^2 + \mathbf{L}^2 \mathbf{r}).
 \end{aligned} \tag{15.62}$$

2. Trivial by the Thomas-Reiche-Kuhn sum rule (4.77).
3. The unperturbed energy eigenvectors are denoted by $|n_x, n_y, n_z\rangle$, where the quantum numbers n_x , n_y and n_z are non-negative integers, and the corresponding eigenenergies are given by

$$E_{n_x, n_y, n_z} = \hbar\omega_0 \left(\frac{3}{2} + n_x + n_y + n_z \right). \tag{15.63}$$

The perturbation is given by [see Eq. (6.600)]

$$\mathcal{V} = -\frac{q}{mc} \mathbf{p} \cdot \mathbf{A} + \frac{q^2}{2mc^2} \mathbf{A}^2, \tag{15.64}$$

where the vector potential \mathbf{A} is given by [see Eq. (6.599)]

$$\mathbf{A} = \frac{B \cos(\omega t)}{2} (-y, x, 0), \tag{15.65}$$

thus in terms of the annihilation operators a_x , a_y and a_z [see Eqs. (5.11) and (5.12)]

$$\begin{aligned}
 \mathcal{V} &= \frac{\omega_c \cos(\omega t)}{2} (yp_x - xp_y) + \frac{m\omega_c^2 \cos^2(\omega t)}{8} (x^2 + y^2) \\
 &= \frac{i\hbar\omega_c \cos(\omega t)}{2} (a_x^\dagger a_y - a_x a_y^\dagger) \\
 &\quad + \frac{\hbar\omega_c^2 \cos^2(\omega t)}{16\omega_0} \left[(a_x + a_x^\dagger)^2 + (a_y + a_y^\dagger)^2 \right],
 \end{aligned} \tag{15.66}$$

where

$$\omega_c = \frac{qB}{mc}. \tag{15.67}$$

Since $(a_x^\dagger a_y - a_x a_y^\dagger) |0, 0, 0\rangle = 0$ the first term has no contribution to transitions from the ground state. The second term gives rise to transitions to the states $|2, 0, 0\rangle$ and $|0, 2, 0\rangle$, and the corresponding matrix elements are given by [see Eq. (5.29)]

$$\langle 2, 0, 0 | \mathcal{V} | 0, 0, 0 \rangle = \langle 0, 2, 0 | \mathcal{V} | 0, 0, 0 \rangle = \frac{\sqrt{2}\hbar\omega_c^2 \cos^2(\omega t)}{16\omega_0}, \quad (15.68)$$

and thus the transition rate w to these states is given by [recall that $\cos^2(\omega t) = (1 + \cos(2\omega t))/2$ and see Eq. (10.40)]

$$w = 2\pi \left(\frac{\omega_c^2}{64\omega_0} \right)^2 \delta(\omega_0 - \omega). \quad (15.69)$$

4. The rate of spontaneous emission per solid angle from initial hydrogen state $|n, l, m\rangle$ to a final hydrogen state $|n', l', m'\rangle$ is given by Eq. (15.14)

$$\frac{d\Gamma_{|n,l,m\rangle \rightarrow |n',l',m'\rangle, \lambda}^{(\text{se})}}{d\Omega} = \frac{\alpha_{\text{fs}} \omega_{|n,l,m\rangle, |n',l',m'\rangle}^3}{2\pi c^2} |M_{|n,l,m\rangle, |n',l',m'\rangle}|^2, \quad (15.70)$$

where $\alpha_{\text{fs}} = e^2/\hbar c$ is the fine-structure constant and the transition frequency $\omega_{|n,l,m\rangle, |n',l',m'\rangle}$ is given by [see Eqs. (7.66) and (7.84)]

$$\omega_{|n,l,m\rangle, |n',l',m'\rangle} = \frac{m_e e^4}{2\hbar^3} \left(-\frac{1}{n^2} + \frac{1}{n'^2} \right), \quad (15.71)$$

thus

$$\frac{d\Gamma_{|n,l,m\rangle \rightarrow |n',l',m'\rangle, \lambda}^{(\text{se})}}{d\Omega} = \Gamma_{\text{H}} \left(-\frac{1}{n^2} + \frac{1}{n'^2} \right)^3 \left| \frac{M_{|n,l,m\rangle, |n',l',m'\rangle}}{a_0} \right|^2, \quad (15.72)$$

where

$$\Gamma_{\text{H}} = \frac{\alpha_{\text{fs}} \left(\frac{m_e e^4}{2\hbar^3} \right)^3 a_0^2}{2\pi c^2} = \frac{\alpha_{\text{fs}}^5 m_e c^2}{16\pi \hbar} = (3.1289 \text{ ns})^{-1}. \quad (15.73)$$

and where $a_0 = \hbar^2/m_e e^2$ is Bohr's radius [see Eq. (7.64)]. In the dipole approximation the matrix element $M_{|n,l,m\rangle, |n',l',m'\rangle}$ is taken to be given by [see Eq. (15.18)]

$$M_{|n,l,m\rangle, |n',l',m'\rangle} = \langle n', l', m' | \hat{\mathbf{e}}_{\mathbf{k}, \lambda}^* \cdot \mathbf{r} | n, l, m \rangle, \quad (15.74)$$

where $\hat{\mathbf{e}}_{\mathbf{k}, \lambda}$ are polarization unit vectors perpendicular to the direction of the emitted photon \mathbf{k} . Using the notation

$$\mathbf{r} = x\hat{\mathbf{x}} + y\hat{\mathbf{y}} + z\hat{\mathbf{z}} = \frac{x - iy}{\sqrt{2}} \hat{\mathbf{u}}_+ + \frac{x + iy}{\sqrt{2}} \hat{\mathbf{u}}_- + z\hat{\mathbf{z}}, \quad (15.75)$$

where the unit vectors $\hat{\mathbf{u}}_+$ are given by

$$\hat{\mathbf{u}}_+ = \frac{\hat{\mathbf{x}} \pm i\hat{\mathbf{y}}}{\sqrt{2}}, \quad (15.76)$$

one obtains

$$\begin{aligned} M_{|n,l,m\rangle,|n',l',m'\rangle} &= \hat{\mathbf{e}}_{\mathbf{k},\lambda}^* \cdot \hat{\mathbf{u}}_+ M_{|n,l,m\rangle,|n',l',m'\rangle,-} \\ &\quad + \hat{\mathbf{e}}_{\mathbf{k},\lambda}^* \cdot \hat{\mathbf{u}}_- M_{|n,l,m\rangle,|n',l',m'\rangle,+} \\ &\quad + \hat{\mathbf{e}}_{\mathbf{k},\lambda}^* \cdot \hat{\mathbf{z}} M_{|n,l,m\rangle,|n',l',m'\rangle,z}, \end{aligned} \quad (15.77)$$

where [see Eq. (7.95) and note that $x \pm iy = r \sin \theta e^{\pm i\phi}$ and $z = r \cos \theta$]

$$\begin{aligned} M_{|n,l,m\rangle,|n',l',m'\rangle,\pm} &= \langle n',l',m' | \frac{x \pm iy}{\sqrt{2}} | n,l,m \rangle \\ &= \int_0^\infty dr r^3 R_{n'l'} R_{nl} \sqrt{\frac{1}{2}} \int_{-1}^1 d(\cos \theta) \int_0^{2\pi} d\phi \sin \theta e^{\pm i\phi} (Y_l^{m'})^* Y_l^m, \end{aligned} \quad (15.78)$$

and

$$\begin{aligned} M_{|n,l,m\rangle,|n',l',m'\rangle,z} &= \langle n',l',m' | z | n,l,m \rangle \\ &= \int_0^\infty dr r^3 R_{n'l'} R_{nl} \int_{-1}^1 d(\cos \theta) \int_0^{2\pi} d\phi \cos \theta (Y_l^{m'})^* Y_l^m. \end{aligned} \quad (15.79)$$

Note that the selection rule (15.25) implies that $M_{|n,l,m\rangle,|n',l',m'\rangle,\pm} \propto \delta_{m'-m,\pm 1}$ and the selection rule (15.23) implies that $M_{|n,l,m\rangle,|n',l',m'\rangle,z} \propto \delta_{m'-m,0}$.

- a) The final state in this case is the ground state $|n' = 1, l' = 0, m' = 0\rangle$. In the dipole approximation the transition $|2, 0, 0\rangle \rightarrow |1, 0, 0\rangle$ is forbidden due to the selection rule $\Delta l \in \{-1, 1\}$ [see Eq. (15.26)]. The following holds [see Eqs. (6.130), (6.131) and (6.132)]

$$\int_{-1}^1 d(\cos \theta) \int_0^{2\pi} d\phi \cos \theta (Y_0^0)^* Y_1^0 = \frac{1}{\sqrt{3}}, \quad (15.80)$$

$$\sqrt{\frac{1}{2}} \int_{-1}^1 d(\cos \theta) \int_0^{2\pi} d\phi \sin \theta e^{-i\phi} (Y_0^0)^* Y_1^1 = -\sqrt{\frac{1}{3}}, \quad (15.81)$$

$$\sqrt{\frac{1}{2}} \int_{-1}^1 d(\cos \theta) \int_0^{2\pi} d\phi \sin \theta e^{i\phi} (Y_0^0)^* Y_1^{-1} = \sqrt{\frac{1}{3}}, \quad (15.82)$$

and [see Eqs. (7.89) and (7.91)]

$$\frac{1}{a_0} \int_0^\infty dr r^3 R_{10} R_{21} = \sqrt{\frac{1}{6}} \int_0^\infty d\rho \rho^4 e^{-\frac{3\rho}{2}} = \frac{2^7 \sqrt{6}}{3^5}, \quad (15.83)$$

thus the states $|2, 1, -1\rangle$, $|2, 1, 0\rangle$ and $|2, 1, 1\rangle$ all have the same decay rate $\Gamma_{21}^{(\text{se})}$, which is given by [see Eq. (15.72)]

$$\begin{aligned} \Gamma_{21}^{(\text{se})} &= 4\pi I_{\text{H}} \left(-\frac{1}{2^2} + \frac{1}{1^2} \right)^3 \left| \frac{2^7 \sqrt{6}}{3^5} \frac{1}{\sqrt{3}} \right|^2 \\ &= (1.06 \text{ ns})^{-1}, \end{aligned} \quad (15.84)$$

whereas the lifetime of the state $|2, 0, 0\rangle$ is infinite (in the dipole approximation).

- b) In the dipole approximation the selection rule $\Delta l \in \{-1, 1\}$ implies that the only allowed decay transitions are $|3, 0, 0\rangle \rightarrow |2, 1, -1\rangle$, $|3, 0, 0\rangle \rightarrow |2, 1, 0\rangle$ and $|3, 0, 0\rangle \rightarrow |2, 1, 1\rangle$. The radial part of the matrix elements corresponding to these transitions is given by [see Eqs. (7.91) and (7.92)]

$$\begin{aligned} &\frac{1}{a_0} \int_0^\infty dr r^3 R_{21} R_{30} \\ &= \left(\frac{1}{6} \right)^{3/2} \frac{2}{\sqrt{3}} \int_0^\infty d\rho \rho^4 \left(1 - \frac{2\rho}{3} + \frac{2\rho^2}{27} \right) e^{-\frac{5\rho}{6}} \\ &= 2^{3/2} \left(\frac{72}{125} \right)^2, \end{aligned} \quad (15.85)$$

and thus the total decay rate of the state $\Gamma_{30}^{(\text{se})}$ is given by [see Eqs. (15.72), (15.80), (15.81) and (15.82)]

$$\begin{aligned} \Gamma_{30}^{(\text{se})} &= 3 \times 4\pi I_{\text{H}} \left(-\frac{1}{3^2} + \frac{1}{2^2} \right)^3 \left| 2^{3/2} \left(\frac{72}{125} \right)^2 \frac{1}{\sqrt{3}} \right|^2 \\ &= (106 \text{ ns})^{-1}, \end{aligned} \quad (15.86)$$

5. The initial state is assumed to be the number state $|n_x, n_y, n_z\rangle = |0, 0, 1\rangle$ (note that the first excited level is 3-fold degenerate). With the help of Eq. (15.14) one finds that for a given polarization unit vector $\hat{\mathbf{e}}$ the spontaneous emission rate per solid angle is given by [see Eq. (5.11)]

$$\begin{aligned} \frac{d\Gamma_{\hat{\epsilon}}}{d\Omega} &= \frac{q^2}{\hbar c} \frac{\omega_0^3}{2\pi c^2} |\langle 0, 0, 1 | (\hat{\epsilon}^* \cdot \mathbf{r}) | 0, 0, 0 \rangle|^2 \\ &= \frac{1}{4\pi} \frac{q^2}{\hbar c} \frac{\hbar\omega_0}{mc^2} \omega_0 |(\hat{\epsilon}^* \cdot \hat{\mathbf{z}})|^2 . \end{aligned} \quad (15.87)$$

Integration yields [note that $\int_{-1}^1 d(\cos\theta) \cos^2\theta = 2/3$]

$$\Gamma = \frac{2}{3} \frac{q^2}{\hbar c} \frac{\hbar\omega_0}{mc^2} \omega_0 . \quad (15.88)$$

6. The probability p_{2pm} to find the atom in the state $|n=2, l=1, m\rangle$ is calculated using Eq. (10.43) together with Eq. (7.84)

$$p_{2pm} = \frac{e^2 E_0^2 \tau^2}{\hbar^2} \left| \int_{-\infty}^{\infty} dt' e^{i\frac{3E_1}{4\hbar}t'} \frac{\tau}{\tau^2 + t'^2} \right|^2 |\langle 2, 1, m | z | 1, 0, 0 \rangle|^2 . \quad (15.89)$$

where

$$E_1 = \frac{\mu e^4}{2\hbar^2} \quad (15.90)$$

is the ionization energy. The following holds

$$\begin{aligned} \int_{-\infty}^{\infty} dt' e^{i\frac{3E_1}{4\hbar}t'} \frac{\tau}{\tau^2 + t'^2} &= \frac{1}{\Omega} \int_{-\infty}^{\infty} \frac{dx e^{ix}}{1 + \left(\frac{x}{\Omega}\right)^2} \\ &= \Omega \int_{-\infty}^{\infty} \frac{dx e^{ix}}{(x - i\Omega)(x + i\Omega)} , \end{aligned} \quad (15.91)$$

where

$$\Omega = \frac{3E_1\tau}{4\hbar} , \quad (15.92)$$

thus with the help of the residue theorem one finds that

$$\int_{-\infty}^{\infty} dt' e^{i\frac{3E_1}{4\hbar}t'} \frac{\tau}{\tau^2 + t'^2} = \pi e^{-\Omega} . \quad (15.93)$$

The matrix element $\langle 2, 1, m | z | 1, 0, 0 \rangle$ is calculated with the help of Eq. (15.79)

$$\begin{aligned} \langle 2, 1, m | z | 1, 0, 0 \rangle &= \int_0^{\infty} dr r^3 R_{21} R_{10} \int_{-1}^1 d(\cos\theta) \int_0^{2\pi} d\phi \cos\theta (Y_1^m)^* Y_0^0 \\ &= \frac{2^7 \sqrt{2} a_0}{3^5} \delta_{m,0} , \end{aligned} \quad (15.94)$$

where

$$a_0 = \frac{\hbar^2}{\mu e^2} \quad (15.95)$$

is the Bohr's radius, thus

$$p_{2pm} = \frac{2^{15}}{3^{10}} \left(\frac{eE_0 a_0 \tau}{\hbar} \pi \right)^2 e^{-\frac{3E_1 \tau}{2\hbar}} \delta_{m,0} . \quad (15.96)$$

7. The oscillator is assumed to move along the z direction. The rate of spontaneous emission $\Gamma_{|n\rangle \rightarrow |0\rangle, \lambda}^{(\text{se})}$ with polarization λ into solid angle $d\Omega$ is given in the dipole approximation by [see Eqs. (15.14) and (15.18)]

$$d\Gamma_{|n\rangle \rightarrow |0\rangle, \lambda}^{(\text{se})} = \frac{q^2 (n\omega)^3}{2\pi \hbar c^3} |\langle 0|z|n\rangle|^2 (\hat{\mathbf{e}}_{\mathbf{k}, \lambda}^* \cdot \hat{\mathbf{z}})^2 d\Omega , \quad (15.97)$$

where $\hat{\mathbf{e}}_{\mathbf{k}, \lambda}^*$ is the polarization unit vector. With the help of Eqs. (5.11), (5.28) and (5.29) one finds that

$$d\Gamma_{|n\rangle \rightarrow |0\rangle, \lambda}^{(\text{se})} = \frac{q^2 (n\omega)^3}{2\pi \hbar c^3} \frac{\hbar n}{2m\omega} \delta_{n,1} (\hat{\mathbf{e}}_{\mathbf{k}, \lambda}^* \cdot \hat{\mathbf{z}})^2 d\Omega . \quad (15.98)$$

Integrating over $d\Omega$ in spherical coordinates θ and ϕ with the help of the relation

$$\int d\Omega \cos^2 \theta = \int_{-\pi}^{\pi} d\phi \int_{-1}^1 d(\cos \theta) \cos^2 \theta = \frac{4\pi}{3} , \quad (15.99)$$

and summing over the two orthogonal polarization yields the total rate of spontaneous emission

$$\Gamma_{|n\rangle \rightarrow |0\rangle}^{(\text{se})} = \frac{2q^2 \omega^2}{3mc^3} \delta_{n,1} . \quad (15.100)$$

8. The wave function of the final state $|\mathbf{k}'\rangle$ has the form $\langle \mathbf{r}' | \mathbf{k}' \rangle = \mathcal{V}^{-1/2} e^{i\mathbf{k}' \cdot \mathbf{r}'}$, where \mathcal{V} is the systems's volume. The perturbation that is induced by the applied electric field can be expressed as $\mathcal{H}_1(t) = \mathcal{K} e^{-i\omega t} + \mathcal{K}^\dagger e^{i\omega t}$, where

$$\mathcal{K} = \frac{eE_0 \mathbf{r} \cdot \hat{\mathbf{u}}}{2} , \quad (15.101)$$

$\mathbf{r} = r(\sin \theta \cos \phi, \sin \theta \sin \phi, \cos \theta)$ is the position vector operator and $\hat{\mathbf{u}} = (\sin \theta_0 \cos \phi_0, \sin \theta_0 \sin \phi_0, \cos \theta_0)$ is a unit vector in the direction of the applied electric field. The matrix element $M_{\mathbf{k}'} = \langle \mathbf{k}' | \mathcal{K} | n=1, l=0, m=0 \rangle$ corresponding to the transition from the ground state $|n=1, l=0, m=0\rangle$ [see Eq. (7.95)] to the final state $|\mathbf{k}'\rangle$ is given by (the z axis is taken to be in the direction of \mathbf{k}')

$$M_{\mathbf{k}'} = \frac{\pi^{-1/2} e E_0 a_0^{-3/2} \mathcal{V}^{-1/2}}{2} \int_0^\infty dr r^2 \int_{-1}^1 d(\cos \theta) \int_0^{2\pi} d\phi e^{-ik'r \cos \theta} e^{-r/a_0} \mathbf{r} \cdot \hat{\mathbf{u}}, \quad (15.102)$$

where

$$\mathbf{r} \cdot \hat{\mathbf{u}} = r \sin \theta \sin \theta_0 \cos(\phi - \phi_0) + r \cos \theta \cos \theta_0, \quad (15.103)$$

thus

$$\begin{aligned} M_{\mathbf{k}'} &= \pi^{1/2} e E_0 a_0^{-3/2} \mathcal{V}^{-1/2} \cos \theta_0 \int_0^\infty dr e^{-r/a_0} r^3 \underbrace{\int_{-1}^1 d(\cos \theta) e^{-ik'r \cos \theta} \cos \theta}_{\frac{i(e^{ik'r(k'r+i)} + e^{-ik'r(k'r-i)})}{(k'r)^2}} \\ &= \pi^{1/2} e E_0 a_0^{-3/2} \mathcal{V}^{-1/2} \cos \theta_0 \frac{16a_0^4 k' a_0}{i((k'a_0)^2 + 1)^3}. \end{aligned} \quad (15.104)$$

The rate of ionization w is obtained by summing over \mathbf{k}' [see Eq. (10.40)]

$$w = \frac{2\pi}{\hbar} \sum_{\mathbf{k}'} \delta(\Delta E_{\mathbf{k}'} - \hbar\omega) |M_{\mathbf{k}'}|^2, \quad (15.105)$$

where

$$\Delta E_{\mathbf{k}'} = \frac{\hbar^2 k'^2}{2m_e} + E_I \quad (15.106)$$

is the change in the energy of the electron and where $E_I = m_e e^4 / 2\hbar^2$ is the ionization energy of the atom [see Eq. (7.66)]. Replacing the sum by an integral according to (14.74) yields

$$w = \frac{256e^2 E_0^2 a_0^3}{3\hbar} \int_0^\infty dk' \delta\left(\frac{\hbar^2 k'^2}{2m_e} + E_I - \hbar\omega\right) \frac{(k'a_0)^4}{((k'a_0)^2 + 1)^6}, \quad (15.107)$$

thus

$$w = \frac{256e^2 m_e E_0^2 a_0^4}{3\hbar^3} \frac{(k_0 a_0)^3}{((k_0 a_0)^2 + 1)^6}, \quad (15.108)$$

where

$$k_0 = \frac{\sqrt{2m_e(\hbar\omega - E_I)}}{\hbar}. \quad (15.109)$$

Note that for a given amplitude E_0 the rate w obtains its maximum value, which is given by [see Eq. (7.64)]

$$w_{\max} = \frac{27\sqrt{3}}{16} \frac{E_0^2 a_0^3}{\hbar}, \quad (15.110)$$

when the angular frequency ω is chosen such that $k_0 a_0 = 3^{-1/2}$.

9. In thermal equilibrium

$$0 = \frac{dN_2}{dt} = B_{12}N_1\rho_0 - B_{21}N_2\rho_0 - A_{21}N_2, \quad (15.111)$$

and thus

$$\frac{A_{21}}{B_{21}} = \left(\frac{B_{12}}{B_{21}} \frac{N_1}{N_2} - 1 \right) \rho_0. \quad (15.112)$$

In thermal equilibrium the ratio N_1/N_2 is given by [see Eq. (8.34)]

$$\frac{N_1}{N_2} = e^{\beta\hbar\omega_0}, \quad (15.113)$$

where $\beta = 1/(k_B T)$. To evaluate the term ρ_0 , the expectation value u_T of the total energy per volume of the electromagnetic field in equilibrium at temperature T is expressed as [see Eq. (14.74) and note that there are two orthogonal states of polarization per a given allowed \mathbf{k} vector]

$$u_T = \frac{2\hbar c}{(2\pi)^3} \int_{-\infty}^{\infty} dk_x \int_{-\infty}^{\infty} dk_y \int_{-\infty}^{\infty} dk_z k \langle n(\mathbf{ck}) \rangle,$$

where $k = \sqrt{k_x^2 + k_y^2 + k_z^2}$, c is speed of light and the number thermal expectation value $\langle n(\omega) \rangle$ is given by the Bose-Einstein function (16.161)

$$\langle n(\omega) \rangle = \frac{1}{e^{\beta\hbar\omega} - 1}, \quad (15.114)$$

thus u_T can be expressed as

$$u_T = \int_0^{\infty} d\omega \rho(\omega), \quad (15.115)$$

where

$$\rho(\omega) = \frac{\hbar\omega^3}{\pi^2 c^3} \langle n(\omega) \rangle, \quad (15.116)$$

and hence

$$\rho_0 = \frac{\hbar\omega_0^3}{\pi^2 c^3} \langle n(\omega_0) \rangle. \quad (15.117)$$

Using these relations Eq. (15.112) becomes

$$\frac{A_{21}}{B_{21}} = \frac{\hbar\omega_0^3}{\pi^2 c^3} \frac{B_{12}}{B_{21}} \frac{e^{\beta\hbar\omega_0} - 1}{e^{\beta\hbar\omega_0} - 1}. \quad (15.118)$$

Since the Einstein's coefficients A_{21} , B_{21} and B_{12} are expected to be temperature independent, one concludes that

$$\frac{B_{12}}{B_{21}} = 1, \quad (15.119)$$

$$\frac{A_{21}}{B_{21}} = \frac{\hbar\omega_0^3}{\pi^2 c^3}. \quad (15.120)$$

Note that the ratio between the total emission rate $B_{21}N_2\rho_0 + A_{21}N_2$ and the rate of spontaneous emission $A_{21}N_2$ is given according to the above findings by

$$\frac{B_{21}N_2\rho_0 + A_{21}N_2}{A_{21}N_2} = \langle n(\omega_0) \rangle + 1, \quad (15.121)$$

in agreement with Eq. (15.12).

10. The energies and wavefunctions of the ground state $|l=0, m=0\rangle$, and the first excited states $|l=1, m=-1\rangle$, $|l=1, m=0\rangle$ and $|l=1, m=1\rangle$, are given by Eqs. (15.19), (6.130), (6.131) and (6.132). In a frame of reference, for which the z axis is parallel to $\langle \mathbf{L} \rangle$, the initial state of the rotator is $|l=1, m=1\rangle$. With the help of Eqs. (15.14) and (15.18) one finds that

$$\begin{aligned} & \frac{d\Gamma_{(1,1,0) \rightarrow (|0,0,1\rangle, \lambda)}^{(e)}}{d\Omega} \\ &= \frac{e^2}{\hbar c} \left(\frac{\hbar}{I}\right)^3 |\langle 1, 0 | (\hat{\mathbf{e}}_{\mathbf{k}, \lambda}^* \cdot \mathbf{r}) | 1, 1 \rangle|^2 \\ &= \frac{e^2}{\hbar c} \left(\frac{\hbar}{I}\right)^3 \left| \int_{-1}^1 d(\cos\theta) \int_0^{2\pi} d\phi (Y_0^0)^* Y_1^1(\hat{\mathbf{e}}_{\mathbf{k}, \lambda}^* \cdot \mathbf{r}) \right|^2, \end{aligned} \quad (15.122)$$

where the vector \mathbf{r} is expressed as

$$\begin{aligned} \frac{\mathbf{r}}{r_0} &= (\sin\theta \cos\phi, \sin\theta \sin\phi, \cos\theta) \\ &= (1, -i, 0) \frac{e^{i\phi} \sin\theta}{2} + (1, i, 0) \frac{e^{-i\phi} \sin\theta}{2} + (0, 0, \cos\theta), \end{aligned} \quad (15.123)$$

thus [see Eqs. (15.80), (15.81) and (15.82)]

$$\frac{d\Gamma_{(1,m),0 \rightarrow (0,0),1,\lambda}^{(e)}}{d\Omega} = \frac{e^2 \left(\frac{\hbar}{I}\right)^3 r_0^2}{24\pi c^2} |\hat{\mathbf{e}}_{\mathbf{k},\lambda}^* \cdot (1, i, 0)|^2. \quad (15.124)$$

For any given $\mathbf{k} = k(\sin\theta' \cos\phi', \sin\theta' \sin\phi', \cos\theta')$, two orthogonal states of polarization, having unit vectors $\hat{\mathbf{e}}_{\mathbf{k},1} = (\cos\theta' \cos\phi', \cos\theta' \sin\phi', -\sin\theta')$ and $\hat{\mathbf{e}}_{\mathbf{k},2} = (-\sin\phi', \cos\phi', 0)$, can contribute to the emission. Angular integration and summation over states of polarization λ yield (recall that $\hbar\omega = \hbar^2/I$ and $d = er_0$)

$$\begin{aligned} w &= \frac{d^2\omega^3}{24\pi c^3 \hbar} \int_{-1}^1 d(\cos\theta') \int_0^{2\pi} d\phi' \left(|\hat{\mathbf{e}}_{\mathbf{k},1}^* \cdot (1, i, 0)|^2 + |\hat{\mathbf{e}}_{\mathbf{k},2}^* \cdot (1, i, 0)|^2 \right) \\ &= \frac{d^2\omega^3}{24\pi c^3 \hbar} \int_{-1}^1 d(\cos\theta') (\cos^2\theta' + 1) \int_0^{2\pi} d\phi' \\ &= \frac{16\pi}{3} \frac{d^2\omega^3}{24\pi c^3 \hbar} \\ &= \frac{2d^2\omega^3}{9c^3 \hbar}. \end{aligned} \quad (15.125)$$

11. The coupling Hamiltonian \mathcal{H}_p between the spin and the EM field is given by [see Eq. (4.19)]

$$\mathcal{H}_p = -\frac{2\mu}{\hbar} \mathbf{S} \cdot \mathbf{B}. \quad (15.126)$$

where \mathbf{S} is the spin angular momentum vector operator, and where [see Eqs. (1.42), (15.5) and (15.31)]

$$\begin{aligned} \mathbf{B} &= \nabla \times \mathbf{A} \\ &= \sum_{\mathbf{k},\lambda} i \sqrt{\frac{2\pi c^2 \hbar}{\omega_{\mathbf{k}} V}} \left((\mathbf{k} \times \hat{\mathbf{e}}_{\mathbf{k},\lambda}) e^{i(\mathbf{k}\cdot\mathbf{r} - \omega_{\mathbf{k}} t)} a_{\mathbf{k},\lambda} - (\mathbf{k} \times \hat{\mathbf{e}}_{\mathbf{k},\lambda}^*) e^{-i(\mathbf{k}\cdot\mathbf{r} - \omega_{\mathbf{k}} t)} a_{\mathbf{k},\lambda}^\dagger \right). \end{aligned} \quad (15.127)$$

The contribution $w_{\mathbf{k},\lambda}$ to the total spontaneous emission rate corresponding to emission of a photon having wave vector \mathbf{k} and polarization λ is given by [see Eqs. (10.35) and (15.126), and recall that $\omega_{\mathbf{k}} = ck$]

$$w_{\mathbf{k},\lambda} = \frac{4\pi^2 c^2 k \mu^2}{\hbar c V} \delta(\omega_{\mathbf{k}} - \omega_L) \left| \langle - | \frac{2\mathbf{S} \cdot (\hat{\mathbf{k}} \times \hat{\mathbf{e}}_{\mathbf{k},\lambda}^*)}{\hbar} | + \rangle \right|^2, \quad (15.128)$$

where $\omega_L = 2\mu H_0/\hbar$ is the Larmor frequency [see Eq. (4.22)], and where $\hat{\mathbf{k}} = \mathbf{k}/|\mathbf{k}|$. The spontaneous emission rate in the infinitesimal solid angle $d\Omega$ having polarization λ is given by

$$\begin{aligned}
 \frac{d\Gamma^{(\text{se})}}{d\Omega} &= \frac{V}{(2\pi)^3} \int_0^\infty dk k^2 w_{\mathbf{k},\lambda} \\
 &= \frac{c^2 \mu^2}{2\pi \hbar c^5} \left| \langle - | \frac{2\mathbf{S} \cdot (\hat{\mathbf{k}} \times \hat{\boldsymbol{\epsilon}}_{\mathbf{k},\lambda}^*)}{\hbar} | + \rangle \right|^2 \int_0^\infty dx x^3 \delta(x - \omega_L) \\
 &= \frac{c^2 \mu^2 \omega_L^3}{2\pi \hbar c^5} \left| \langle - | \frac{2\mathbf{S} \cdot (\hat{\mathbf{k}} \times \hat{\boldsymbol{\epsilon}}_{\mathbf{k},\lambda}^*)}{\hbar} | + \rangle \right|^2 .
 \end{aligned}
 \tag{15.129}$$

The total rate is found by integrating over $d\Omega$ in spherical coordinates [see Eq. (15.99)]

$$\Gamma^{(\text{se})} = \frac{4c^2 \mu^2 \omega_L^3}{3\hbar c^5} = \frac{32\mu^5 H_0^3}{3\hbar^4 c^3} .
 \tag{15.130}$$

In terms of the Bohr's magneton μ_B (2.89) and fine-structure constant α_{fs} (15.15) $\Gamma^{(\text{se})}$ is given by

$$\Gamma^{(\text{se})} = \left(\frac{\mu}{\mu_B} \frac{\hbar \omega_L}{m_e c^2} \right)^2 \frac{\alpha_{\text{fs}} \omega_L}{3} .
 \tag{15.131}$$

16. Identical Particles

This chapter reviews the identical particles postulate of quantum mechanics and second quantization formalism. It is mainly based on the first chapter of Ref. [6].

16.1 Basis for the Hilbert Space

Consider a system containing some integer number N of identical particles. For the single particle case, where $N = 1$, the state of the system $|\alpha\rangle$ can be expanded using an orthonormal basis $\{|a_i\rangle\}_i$ that spans the single particle Hilbert space. Based on the single particle basis $\{|a_i\rangle\}_i$ we wish to construct a basis for the Hilbert space of the system for the general case, where N can be any integer. This can be done in two different ways, depending on whether the identical particles are considered to be *distinguishable* or *indistinguishable* (see example in Fig. 16.1).

Suppose that the particles can be labelled by numbers as billiard balls. In this approach the particles are considered as distinguishable. For this case a basis for the Hilbert space of the many-particle system can be constructed from all vectors having the form $|1 : i_1, 2 : i_2, \dots, N : i_N\rangle$. The ket vector $|1 : i_1, 2 : i_2, \dots, N : i_N\rangle$ represents a state having N particles, where the particle that is labelled by the number m ($m = 1, 2, \dots, N$) is in the single particle state $|a_{i_m}\rangle$. Each ket vector $|1 : i_1, 2 : i_2, \dots, N : i_N\rangle$ can be characterized by a vector of occupation numbers $\bar{n} = (n_1, n_2, \dots)$, where n_i is the number of particles occupying the single particle state $|a_i\rangle$. Let $g_{\bar{n}}$ be the number of different ket-vectors having the form $|1 : i_1, 2 : i_2, \dots, N : i_N\rangle$ that are characterized by the same vector of occupation numbers \bar{n} . It is easy to show that

$$g_{\bar{n}} = \frac{N!}{\prod_i n_i!}, \quad (16.1)$$

where $N = \sum_i n_i$ is the number of particles.

Alternatively, the particles can be considered as indistinguishable. In this approach all states having the same vector of occupation numbers \bar{n} represent the same physical state, and thus should be counted only once. In

other words, when the particles are considered as indistinguishable the subspace corresponding to any given vector of occupation numbers \bar{n} is rather than being $g_{\bar{n}}$ - fold degenerate (as in the approach where the particles are considered to be distinguishable) is taken to be nondegenerate. The identical particle postulate of quantum mechanics states that identical particles should be considered as indistinguishable. Consequently, a basis for the Hilbert space of the many-particle system can be constructed from the set of ket vectors $\{|\bar{n}\rangle\}_{\bar{n}}$. The ket vector $|\bar{n}\rangle$ represents a state that is characterized by a vector of occupation numbers $\bar{n} = (n_1, n_2, \dots)$, where the integer n_i is the number of particles that are in the single particle state $|a_i\rangle$. Such a basis is considered to be both orthonormal, i.e.

$$\langle \bar{n}_1 | \bar{n}_2 \rangle = \delta_{\bar{n}_1, \bar{n}_2} , \quad (16.2)$$

where $\delta_{\bar{n}_1, \bar{n}_2} = 1$ if $\bar{n}_1 = \bar{n}_2$ and $\delta_{\bar{n}_1, \bar{n}_2} = 0$ otherwise, and complete

$$\sum_{\bar{n}'} |\bar{n}'\rangle \langle \bar{n}'| = 1 . \quad (16.3)$$

It is convenient to introduce the creation operators a_i^\dagger . With analogy with the case of a harmonic oscillator [see Eq. (5.32)] and the case of EM field [see Eqs. (14.69) and (14.70)] the state $|\bar{n}\rangle$ is expressed as

$$|\bar{n}\rangle = \frac{1}{\sqrt{n_1! n_2! \dots}} \left(a_1^\dagger\right)^{n_1} \left(a_2^\dagger\right)^{n_2} \dots |0\rangle , \quad (16.4)$$

where $|0\rangle$ represents the state where all occupation numbers are zero. Equation (16.4) suggests that the creation operators a_i^\dagger maps a given state to a state having additional particle in the single particle quantum state $|a_i\rangle$. The operator a_i^\dagger is the Hermitian conjugate of the annihilation operator a_i . The number operator N_i is defined by

$$N_i = a_i^\dagger a_i . \quad (16.5)$$

In addition to the above discussed principle of indistinguishability, the identical particle postulate of quantum mechanics also states that all particles in nature are divided into two type: Bosons and Fermions. Moreover, while for the case of Bosons, the creation and annihilation operators satisfy the following commutation relations

$$[a_i, a_j] = [a_i^\dagger, a_j^\dagger] = 0 , \quad (16.6)$$

$$[a_i, a_j^\dagger] = \delta_{ij} , \quad (16.7)$$

for the case of Fermions the following holds

$$[a_i, a_j]_+ = [a_i^\dagger, a_j^\dagger]_+ = 0 , \quad (16.8)$$

$$[a_i, a_j^\dagger]_+ = \delta_{ij} , \quad (16.9)$$

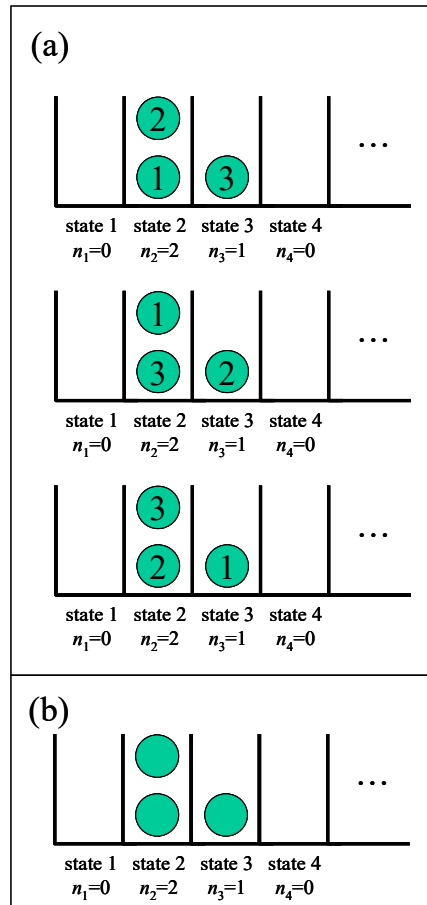

Fig. 16.1. In this example the number of particles is $N = \sum_i n_i = 3$, where the occupation numbers are given by $\bar{n} = (n_1, n_2, n_3, n_4, \dots) = (0, 2, 1, 0, \dots)$. When the particles are considered as distinguishable [see panel (a)] the corresponding subspace is $g_{\bar{n}}$ degenerate, where $g_{\bar{n}} = N! / \prod_i n_i! = 3$. On the other hand, when the particles are considered as indistinguishable [see panel (b)], the corresponding subspace is nondegenerate.

where $[a_i, a_j^\dagger]_+$ denotes anti-commutation, i.e.

$$[A, B]_+ = AB + BA \quad (16.10)$$

for general operators A and B .

Exercise 16.1.1. Show that for both Bosons and Fermions

$$[N_i, N_j] = 0. \quad (16.11)$$

Solution 16.1.1. For Bosons this result is trivial [see Eqs. (16.6) and (16.7)]. It is also trivial for Fermions when $i = j$. Finally, for Fermions when $i \neq j$ one has

$$N_i N_j = a_i^\dagger a_i a_j^\dagger a_j = -a_i^\dagger a_j^\dagger a_i a_j = a_i^\dagger a_j^\dagger a_j a_i = -a_j^\dagger a_i^\dagger a_j a_i = a_j^\dagger a_j a_i^\dagger a_i = N_j N_i . \quad (16.12)$$

16.2 Bosons

Based on Eqs. (16.2), (16.4), (16.6) and (16.7) a variety of results can be obtained:

Exercise 16.2.1. Show that for Bosons

$$\left[a_i, \left(a_i^\dagger \right)^n \right] = n \left(a_i^\dagger \right)^{n-1} . \quad (16.13)$$

Solution 16.2.1. Trivial by Eq. (2.183), which states that for any operators A and B

$$[A, B^n] = n B^{n-1} [A, B] , \quad (16.14)$$

and by Eq. (16.7).

Exercise 16.2.2. Show that for Bosons

$$a_i |0\rangle = 0 . \quad (16.15)$$

Solution 16.2.2. The norm of the vector $a_i |0\rangle$ can be expressed with the help of Eqs. (16.4) and (16.7)

$$\begin{aligned} \langle 0 | a_i^\dagger a_i |0\rangle &= \langle 0 | \left[a_i^\dagger, a_i \right] + a_i a_i^\dagger |0\rangle \\ &= -\langle 0 |0\rangle + \langle 0, 0, \dots, n_i = 1, 0, \dots |0, 0, \dots, n_i = 1, 0, \dots \rangle , \end{aligned} \quad (16.16)$$

thus with the help of the normalization condition (16.2) one finds that $\langle 0 | a_i^\dagger a_i |0\rangle = 0$ and therefore $a_i |0\rangle = 0$.

Exercise 16.2.3. Show that for Bosons

$$N_i |\vec{n}\rangle = n_i |\vec{n}\rangle . \quad (16.17)$$

Solution 16.2.3. With the help of Eqs. (16.4), (16.13) and (16.15) one finds that

$$\begin{aligned}
N_i |\bar{n}\rangle &= a_i^\dagger a_i |\bar{n}\rangle \\
&= \frac{1}{\sqrt{n_1! n_2! \dots}} (a_1^\dagger)^{n_1} (a_2^\dagger)^{n_2} \dots a_i^\dagger a_i (a_i^\dagger)^{n_i} \dots |0\rangle \\
&= \frac{1}{\sqrt{n_1! n_2! \dots}} (a_1^\dagger)^{n_1} (a_2^\dagger)^{n_2} \dots a_i^\dagger \left([a_i, (a_i^\dagger)^{n_i}] + (a_i^\dagger)^{n_i} a_i \right) \dots |0\rangle \\
&= \frac{1}{\sqrt{n_1! n_2! \dots}} (a_1^\dagger)^{n_1} (a_2^\dagger)^{n_2} \dots a_i^\dagger n_i (a_i^\dagger)^{n_i-1} \dots |0\rangle \\
&= n_i |\bar{n}\rangle .
\end{aligned} \tag{16.18}$$

Exercise 16.2.4. Show that for Bosons

$$a_i |n_1, n_2, \dots, n_i, \dots\rangle = \sqrt{n_i} |n_1, n_2, \dots, n_i - 1, \dots\rangle , \tag{16.19}$$

$$a_i^\dagger |n_1, n_2, \dots, n_i, \dots\rangle = \sqrt{n_i + 1} |n_1, n_2, \dots, n_i + 1, \dots\rangle . \tag{16.20}$$

Solution 16.2.4. Equation (16.20) follows immediately from Eqs. (16.4) and (16.6). Moreover, with the help of Eqs. (16.4), (16.13) and (16.15) one finds that

$$\begin{aligned}
a_i |n_1, n_2, \dots, n_i, \dots\rangle &= \frac{1}{\sqrt{n_1! n_2! \dots}} (a_1^\dagger)^{n_1} (a_2^\dagger)^{n_2} \dots a_i (a_i^\dagger)^{n_i} \dots |0\rangle \\
&= \frac{1}{\sqrt{n_1! n_2! \dots}} (a_1^\dagger)^{n_1} (a_2^\dagger)^{n_2} \dots \left([a_i, (a_i^\dagger)^{n_i}] + (a_i^\dagger)^{n_i} a_i \right) \dots |0\rangle \\
&= \frac{n_i}{\sqrt{n_1! n_2! \dots}} (a_1^\dagger)^{n_1} (a_2^\dagger)^{n_2} \dots (a_i^\dagger)^{n_i-1} \dots |0\rangle \\
&= \sqrt{n_i} |n_1, n_2, \dots, n_i - 1, \dots\rangle .
\end{aligned}$$

16.3 Fermions

The anti-commutation relations (16.8) for the case $i = j$ yields $(a_i^\dagger)^2 = 0$. As can be seen from Eq. (16.4), this implies that the only possible occupation numbers n_i are 0 and 1. This result is known as the Pauli's exclusion principle, according to which no more than one Fermion can occupy a given single particle state. For Fermions Eq. (16.4) can be written as (recall that $0! = 1! = 1$)

$$|\bar{n}\rangle = (a_1^\dagger)^{n_1} (a_2^\dagger)^{n_2} \dots |0\rangle , \tag{16.21}$$

where $n_i \in \{0, 1\}$.

Exercise 16.3.1. Show that for Fermions

$$a_i |0\rangle = 0 . \tag{16.22}$$

Solution 16.3.1. The norm of the vector $a_i |0\rangle$ can be expressed with the help of Eqs. (16.21) and (16.9)

$$\begin{aligned} \langle 0 | a_i^\dagger a_i | 0 \rangle &= \langle 0 | \left[a_i^\dagger, a_i \right]_+ - a_i a_i^\dagger | 0 \rangle \\ &= \langle 0 | 0 \rangle - \langle 0, 0, \dots, n_i = 1, 0, \dots | 0, 0, \dots, n_i = 1, 0, \dots \rangle, \end{aligned} \quad (16.23)$$

thus with the help of the normalization condition (16.2) one finds that $\langle 0 | a_i^\dagger a_i | 0 \rangle = 0$ and therefore $a_i |0\rangle = 0$.

Exercise 16.3.2. Show that for Fermions

$$N_i |\bar{n}\rangle = n_i |\bar{n}\rangle, \quad (16.24)$$

where $N_i = a_i^\dagger a_i$.

Solution 16.3.2. Using Eqs. (16.8), (16.9) and (16.21) one finds that

$$\begin{aligned} N_i |\bar{n}\rangle &= a_i^\dagger a_i \left(a_1^\dagger \right)^{n_1} \left(a_2^\dagger \right)^{n_2} \cdots |0\rangle \\ &= (-1)^{2 \sum_{j < i} n_j} \left(a_1^\dagger \right)^{n_1} \left(a_2^\dagger \right)^{n_2} \cdots a_i^\dagger a_i \left(a_i^\dagger \right)^{n_i} \cdots |0\rangle \\ &= \left(a_1^\dagger \right)^{n_1} \left(a_2^\dagger \right)^{n_2} \cdots a_i^\dagger a_i \left(a_i^\dagger \right)^{n_i} \cdots |0\rangle. \end{aligned} \quad (16.25)$$

For the case $n_i = 0$ this yields [see Eq. (16.22)] $N_i |\bar{n}\rangle = 0$, whereas for the case $n_i = 1$ one has $a_i \left(a_i^\dagger \right)^{n_i} = \left[a_i, a_i^\dagger \right]_+ - a_i^\dagger a_i = 1 - a_i^\dagger a_i$, thus $N_i |\bar{n}\rangle = |\bar{n}\rangle$. Both cases are in agreement with Eq. (16.24).

Exercise 16.3.3. Show that for Fermions

$$N_i (1 - N_i) = 0, \quad (16.26)$$

where $N_i = a_i^\dagger a_i$.

Solution 16.3.3. With the help of Eqs. (16.8) and (16.9) one finds that $N_i^2 = a_i^\dagger a_i a_i^\dagger a_i = a_i^\dagger (1 - a_i^\dagger a_i) a_i = N_i - \left(a_i^\dagger \right)^2 (a_i)^2 = N_i$, thus $N_i (1 - N_i) = 0$. Note that this result implies that for Fermions the number operator N_i is a projector [see Eq. (2.61)].

Exercise 16.3.4. Show that for Fermions

$$a_i |n_1, n_2, \dots, n_i, \dots\rangle = n_i (-1)^{\sum_{j < i} n_j} |n_1, n_2, \dots, n_i - 1, \dots\rangle, \quad (16.27)$$

$$a_i^\dagger |n_1, n_2, \dots, n_i, \dots\rangle = (1 - n_i) (-1)^{\sum_{j < i} n_j} |n_1, n_2, \dots, n_i + 1, \dots\rangle \quad (16.28)$$

Solution 16.3.4. According to Eq. (16.8) $a_i^\dagger a_j^\dagger = -a_j^\dagger a_i^\dagger$. For $i = j$ this yields $(a_i^\dagger)^2 = 0$. These relations together with Eq. (16.21) leads to Eq. (16.28) (note that $1 - n_i = 1$ if $n_i = 0$ and $1 - n_i = 0$ if $n_i = 1$). Similarly, Eq. (16.27) is obtained by using the identity $a_i (a_i^\dagger)^{n_i} = 1 - a_i^\dagger a_i$ and by considering both possibilities $n_i = 0$ and $n_i = 1$.

16.4 Changing the Basis

In the previous section the creation a_i^\dagger and annihilation a_i operators were defined based on a given single particle orthonormal basis $\{|a_i\rangle\}_i$. Consider an alternative single particle basis $\{|b_j\rangle\}_j$, which is made of eigenvectors of the single particle observable B_{SP} , i.e. the following holds $B_{\text{SP}}^\dagger = B_{\text{SP}}$ and

$$B_{\text{SP}} |b_j\rangle = \beta_j |b_j\rangle , \quad (16.29)$$

where β_j is the single particle eigenvalue corresponding to the eigenvector $|b_j\rangle$. Moreover, this basis is assumed to be both orthonormal, i.e.

$$\langle b_j | b_{j'} \rangle = \delta_{j,j'} , \quad (16.30)$$

and complete, i.e.

$$\sum_j |b_j\rangle \langle b_j| = 1 . \quad (16.31)$$

Exploiting the completeness of the original single particle orthonormal basis $\{|a_i\rangle\}_i$, i.e. the fact that

$$\sum_i |a_i\rangle \langle a_i| = 1 , \quad (16.32)$$

allows expressing the eigenvector $|b_j\rangle$ as

$$|b_j\rangle = \sum_i \langle a_i | b_j \rangle |a_i\rangle . \quad (16.33)$$

The single particle state $|a_i\rangle$ can be expressed in the notation of many particle states as $a_i^\dagger |0\rangle$, whereas the single particle state $|b_j\rangle$ can be expressed as $b_j^\dagger |0\rangle$, where the operator b_j^\dagger , which is the creation operator of the single particle state $|b_j\rangle$, is given by [see Eq. (16.33)]

$$b_j^\dagger = \sum_i \langle a_i | b_j \rangle a_i^\dagger . \quad (16.34)$$

The creation operator b_j^\dagger is the Hermitian conjugate of the annihilation operator

$$b_j = \sum_i \langle b_j | a_i \rangle a_i . \quad (16.35)$$

An important example is the case where the single particle observable is taken to be the position observable \mathbf{r} . For this case Eq. (16.33) becomes

$$|\mathbf{r}'\rangle = \sum_i \psi_i^*(\mathbf{r}') |a_i\rangle , \quad (16.36)$$

where $|\mathbf{r}'\rangle$ is a single particle position eigenvector, and where $\psi_i(\mathbf{r}') = \langle \mathbf{r}' | a_i \rangle$ is the wavefunction of the single particle state $|a_i\rangle$.

Expressing the single particle state $|a_i\rangle$ in the notation of many particle states as $a_i^\dagger |0\rangle$ allows expressing the single particle state $|\mathbf{r}'\rangle$ in the notation of many particle states as $\Psi^\dagger(\mathbf{r}') |0\rangle$ [see Eq. (16.36)], where the operator $\Psi^\dagger(\mathbf{r}')$, which is given by

$$\Psi^\dagger(\mathbf{r}') = \sum_i \psi_i^*(\mathbf{r}') a_i^\dagger , \quad (16.37)$$

is the Hermitian conjugate of the quantized field operator $\Psi(\mathbf{r}')$, which is given by

$$\Psi(\mathbf{r}') = \sum_i \psi_i(\mathbf{r}') a_i . \quad (16.38)$$

Note that while $\psi_i(\mathbf{r}')$ is a wave function, $\Psi(\mathbf{r}')$ is an operator on the Hilbert space of the many particle system.

Exercise 16.4.1. Calculate $[\Psi(\mathbf{r}'), \Psi^\dagger(\mathbf{r}'')]_{\mp}$, where $[A, B]_{\mp} = AB \mp BA$ for general operators A and B , and where the minus sign is used for Bosons and the plus sign for Fermions.

Solution 16.4.1. With the help of Eqs. (16.7) and (16.9) one finds that

$$\begin{aligned} [\Psi(\mathbf{r}'), \Psi^\dagger(\mathbf{r}'')]_{\mp} &= \sum_{i, i'} \psi_i(\mathbf{r}') \psi_{i'}^*(\mathbf{r}'') [a_i, a_{i'}^\dagger]_{\mp} \\ &= \sum_i \psi_i(\mathbf{r}') \psi_i^*(\mathbf{r}'') \\ &= \sum_i \langle \mathbf{r}' | a_i \rangle \langle a_i | \mathbf{r}'' \rangle \\ &= \langle \mathbf{r}' | \mathbf{r}'' \rangle , \end{aligned} \quad (16.39)$$

thus [see Eq. (3.66)]

$$[\Psi(\mathbf{r}'), \Psi^\dagger(\mathbf{r}'')]_{\mp} = \delta(\mathbf{r}' - \mathbf{r}'') . \quad (16.40)$$

Similarly, one finds that

$$[\Psi(\mathbf{r}'), \Psi(\mathbf{r}'')]_{\mp} = 0 , \quad (16.41)$$

$$[\Psi^\dagger(\mathbf{r}'), \Psi^\dagger(\mathbf{r}'')]_{\mp} = 0 . \quad (16.42)$$

Exercise 16.4.2. Show that

$$\int d^3\mathbf{r}' \rho(\mathbf{r}') = N , \quad (16.43)$$

where

$$\rho(\mathbf{r}') = \Psi^\dagger(\mathbf{r}') \Psi(\mathbf{r}') , \quad (16.44)$$

and where

$$N = \sum_i N_i \quad (16.45)$$

The operator $\rho(\mathbf{r}')$ is called the number density operator, and the operator N is called the total number of particles operator.

Solution 16.4.2. Using the definition of $\Psi(\mathbf{r}')$ one finds that

$$\begin{aligned} \int d^3\mathbf{r}' \Psi^\dagger(\mathbf{r}') \Psi(\mathbf{r}') &= \sum_{i,i'} a_i^\dagger a_i \int d^3\mathbf{r}' \psi_{i'}^*(\mathbf{r}') \psi_i(\mathbf{r}') \\ &= \sum_i a_i^\dagger a_i \\ &= N . \end{aligned} \quad (16.46)$$

16.5 Many Particle Observables

Observables of a system of identical particles must be defined and must be represented by Hermitian operators in a way that is consistent with the principle of indistinguishability. Below we consider both, one-particle observables and two-particle observables, and discuss their representation as operators on the Hilbert space of the many-particle system.

16.5.1 One-Particle Observables

Consider a single particle observable such as the observable B_{SP} , which was introduced in the previous section [see Eqs. (16.29), (16.30), (16.31)]. It is

convenient to employ the single particle basis $\{|b_j\rangle\}_j$, which is made of single-particle eigenvectors of B_{SP} that satisfy $B_{\text{SP}} |b_j\rangle = \beta_j |b_j\rangle$ [see Eq. (16.29)], in order to construct creation b_j^\dagger and annihilation b_j operators. In the many-particle case, the same physical variable that B_{SP} represents for the single particle case is represented by the operator B , which is given by

$$B = \sum_j \beta_j b_j^\dagger b_j . \quad (16.47)$$

This can be seen by recalling that the operator $b_j^\dagger b_j$ represents the number of particles in the single particle state $|b_j\rangle$ and that β_j is the corresponding eigenvalue. With the help of Eqs. (16.29), (16.30), (16.31) and (16.34) (16.35) the operator B can be expressed in terms of the operators a_i^\dagger and a_i

$$B = \sum_{i,i'} \langle a_{i'} | B_{\text{SP}} | a_i \rangle a_i^\dagger a_i . \quad (16.48)$$

16.5.2 Two-Particle Observables

Consider two-body interaction that is represented by an Hermitian operator V_{TP} on the Hilbert space of two-particle states. A basis for this Hilbert space can be constructed using a given orthonormal basis for the single particle Hilbert space $\{|b_j\rangle\}_j$. When the two particles are considered as distinguishable the basis of the Hilbert space of the two-particle states can be taken to be $\{|j, j'\rangle\}_{j,j'}$. The ket vector $|j, j'\rangle$ represents a state for which the first particle is in single particle state $|b_j\rangle$ and the second one is in state $|b_{j'}\rangle$. Assume the case where the single particle basis vectors $|b_j\rangle$ are chosen in such a way that diagonalizes V_{TP} , i.e.

$$V_{\text{TP}} |j, j'\rangle = v_{j,j'} |j, j'\rangle , \quad (16.49)$$

where the eigenvalue $v_{j,j'}$ is given by

$$v_{j,j'} = \langle j, j' | V_{\text{TP}} | j, j' \rangle . \quad (16.50)$$

In the many-particle case, the same physical variable that V_{TP} represents for the two-particle case is represented by the operator V , which is given by

$$V = \frac{1}{2} \sum_{j,j'} v_{j,j'} b_j^\dagger b_{j'}^\dagger b_{j'} b_j . \quad (16.51)$$

To see that the above expression indeed represents the two particle interaction consider the expectation value $\langle \bar{n} | V | \bar{n} \rangle$ with respect to the many body state $|\bar{n}\rangle = |n_1, n_2, \dots\rangle$. The following holds [see Eqs. (16.6) , (16.7), (16.8) and (16.9)]

$$\begin{aligned}
 b_j^\dagger b_{j'}^\dagger b_j b_{j'} &= \pm b_j^\dagger b_{j'}^\dagger b_j b_{j'} \\
 &= \pm b_j^\dagger \left(\left[b_{j'}^\dagger, b_j \right]_{\mp} \pm b_j b_{j'}^\dagger \right) b_{j'} \\
 &= \pm b_j^\dagger \left(\mp \left[b_j, b_{j'}^\dagger \right]_{\mp} \pm b_j b_{j'}^\dagger \right) b_{j'} \\
 &= \pm b_j^\dagger \left(\mp \delta_{j,j'} \pm b_j b_{j'}^\dagger \right) b_{j'} \\
 &= -N_j \delta_{j,j'} + N_j N_{j'} ,
 \end{aligned} \tag{16.52}$$

where the upper sign is used for Bosons and the lower one for Fermions. Thus V can be rewritten as

$$V = \frac{1}{2} \sum_{j,j'} v_{j,j'} N_j (N_{j'} - \delta_{j,j'}) . \tag{16.53}$$

Separating the terms for which $j \neq j'$ from the terms for which $j = j'$ yields

$$V = \sum_{j < j'} v_{j,j'} N_j N_{j'} + \frac{1}{2} \sum_j v_{j,j} N_j (N_j - 1) , \tag{16.54}$$

thus the matrix element $\langle \bar{n} | V | \bar{n} \rangle$ is given by

$$\langle \bar{n} | V | \bar{n} \rangle = \sum_{j < j'} n_j n_{j'} v_{j,j'} + \sum_j \frac{n_j (n_j - 1)}{2} v_{j,j} . \tag{16.55}$$

While the factor $n_j n_{j'}$ represents the number of particle pairs occupying single particle states j and j' for the case $j \neq j'$, the factor $n_j (n_j - 1) / 2$ represents the number of particle pairs occupying the same single particle states j . Thus the above expression for V (16.51) properly accounts for the two-particle interaction.

With the help of Eqs. (16.30), (16.31) and (16.34) (16.35) the operator V can be expressed in terms of the operators a_i^\dagger and a_i

$$\begin{aligned}
 V &= \frac{1}{2} \sum_{i',i'',i''',i''''} \sum_{j,j'} \langle a_{i'}, a_{i''} | j, j' \rangle \langle j, j' | V_{\text{TP}} | j, j' \rangle \langle j', j | a_{i''''}, a_{i''''} \rangle a_{i'}^\dagger a_{i''}^\dagger a_{i''''} a_{i''''} \\
 &= \frac{1}{2} \sum_{i',i'',i''',i''''} \sum_{j,j'} \langle a_{i'}, a_{i''} | j, j' \rangle \langle j, j' | V_{\text{TP}} | j, j' \rangle \langle j, j' | a_{i''''}, a_{i''''} \rangle a_{i'}^\dagger a_{i''}^\dagger a_{i''''} a_{i''''} \\
 &= \frac{1}{2} \sum_{i',i'',i''',i''''} \langle a_{i'}, a_{i''} | \left(\sum_{j,j'} | j, j' \rangle \langle j, j' | \right) V_{\text{TP}} | a_{i''''}, a_{i''''} \rangle a_{i'}^\dagger a_{i''}^\dagger a_{i''''} a_{i''''} ,
 \end{aligned} \tag{16.56}$$

thus

$$V = \frac{1}{2} \sum_{i',i'',i''',i''''} \langle a_{i'}, a_{i''} | V_{\text{TP}} | a_{i''''}, a_{i''''} \rangle a_{i'}^\dagger a_{i''}^\dagger a_{i''''} a_{i''''} . \tag{16.57}$$

16.6 Hamiltonian

Consider the case where the single-particle Hamiltonian is given by

$$\mathcal{H}_{\text{SP}} = T_{\text{SP}} + U_{\text{SP}} , \quad (16.58)$$

where the operator T_{SP} , which is given by

$$T_{\text{SP}} = \frac{\mathbf{p}_{\text{SP}}^2}{2m} , \quad (16.59)$$

where \mathbf{p}_{SP} is the single-particle momentum vector operator and where m is the mass of a particle, is the single-particle kinetic energy operator, and where the operator $U_{\text{SP}}(\mathbf{r}')$ is the single-particle potential energy. The many-particle kinetic energy operator is found using Eq. (16.48)

$$T = \frac{1}{2m} \sum_{i,i'} \langle a_{i'} | \mathbf{p}_{\text{SP}}^2 | a_i \rangle a_{i'}^\dagger a_i . \quad (16.60)$$

The matrix element $\langle a_{i'} | \mathbf{p}_{\text{SP}}^2 | a_i \rangle$ can be written using the wavefunctions $\psi_i(\mathbf{r}') = \langle \mathbf{r}' | a_i \rangle$ [recall Eq. (3.29), according to which $\langle \mathbf{r}' | \mathbf{p} | \alpha \rangle = -i\hbar \nabla \psi_\alpha$ for a general state $|\alpha\rangle$]

$$\langle a_{i'} | \mathbf{p}_{\text{SP}}^2 | a_i \rangle = \frac{\hbar^2}{2m} \int d^3\mathbf{r}' (\nabla \psi_{i'}^*(\mathbf{r}')) \cdot (\nabla \psi_i(\mathbf{r}')) . \quad (16.61)$$

Thus, in terms of the quantized field operator $\Psi(\mathbf{r}')$ [see Eqs. (16.37) and (16.38)] the operator T can be expressed as

$$T = \frac{\hbar^2}{2m} \int d^3\mathbf{r}' \nabla \Psi^\dagger(\mathbf{r}') \cdot \nabla \Psi(\mathbf{r}') . \quad (16.62)$$

Integration by parts yields an alternative expression

$$T = -\frac{\hbar^2}{2m} \int d^3\mathbf{r}' \Psi^\dagger(\mathbf{r}') \nabla^2 \Psi(\mathbf{r}') . \quad (16.63)$$

Similarly, the many-particle potential energy operator is found using Eq. (16.48) [recall Eq. (3.23), according to which $\langle \mathbf{r}' | f(\mathbf{r}) | \alpha \rangle = f(\mathbf{r}') \psi_\alpha(\mathbf{r}')$ for a general state $|\alpha\rangle$ and for a general function $f(\mathbf{r})$]

$$\begin{aligned} U &= \sum_{i,i'} \langle a_{i'} | U_{\text{SP}}(\mathbf{r}') | a_i \rangle a_{i'}^\dagger a_i \\ &= \int d^3\mathbf{r}' U_{\text{SP}}(\mathbf{r}') \Psi^\dagger(\mathbf{r}') \Psi(\mathbf{r}') . \end{aligned} \quad (16.64)$$

In addition, consider the case where the particles interact with each other via a two-particle potential $V_{\text{TP}}(\mathbf{r}_1, \mathbf{r}_2)$. The corresponding many-particle

interaction operator is found using Eq. (16.57). The two-particle matrix elements of V_{TP} are given by

$$\begin{aligned} & \langle a_{i'}, a_{i''} | V_{\text{TP}} | a_{i'''}, a_{i''''} \rangle \\ &= \int d^3\mathbf{r}' \int d^3\mathbf{r}'' \psi_{i'}^*(\mathbf{r}') \psi_{i''}^*(\mathbf{r}'') V_{\text{TP}}(\mathbf{r}', \mathbf{r}'') \psi_{i'''}(\mathbf{r}') \psi_{i''''}(\mathbf{r}'') , \end{aligned} \quad (16.65)$$

thus

$$V = \frac{1}{2} \int d^3\mathbf{r}' \int d^3\mathbf{r}'' V_{\text{TP}}(\mathbf{r}', \mathbf{r}'') \Psi^\dagger(\mathbf{r}') \Psi^\dagger(\mathbf{r}'') \Psi(\mathbf{r}') \Psi(\mathbf{r}'') . \quad (16.66)$$

Combining all these results yields the total many-particle Hamiltonian

$$\begin{aligned} \mathcal{H} &= \frac{\hbar^2}{2m} \int d^3\mathbf{r}' \nabla \Psi^\dagger(\mathbf{r}') \cdot \nabla \Psi(\mathbf{r}') \\ &+ \int d^3\mathbf{r}' U_{\text{SP}}(\mathbf{r}') \Psi^\dagger(\mathbf{r}') \Psi(\mathbf{r}') \\ &+ \frac{1}{2} \int d^3\mathbf{r}' \int d^3\mathbf{r}'' V_{\text{TP}}(\mathbf{r}', \mathbf{r}'') \Psi^\dagger(\mathbf{r}') \Psi^\dagger(\mathbf{r}'') \Psi(\mathbf{r}') \Psi(\mathbf{r}'') . \end{aligned} \quad (16.67)$$

Exercise 16.6.1. Show that the Heisenberg equation of motion for the field operator $\Psi(\mathbf{r}')$ is given by

$$\begin{aligned} & i\hbar \frac{d}{dt} \Psi(\mathbf{r}', t) \\ &= \left(-\frac{\hbar^2}{2m} \nabla^2 + U_{\text{SP}}(\mathbf{r}') \right) \Psi(\mathbf{r}', t) \\ &+ \int d^3\mathbf{r}'' V_{\text{TP}}(\mathbf{r}', \mathbf{r}'') \Psi^\dagger(\mathbf{r}'', t) \Psi(\mathbf{r}'', t) \Psi(\mathbf{r}', t) . \end{aligned} \quad (16.68)$$

Note that in the absence of two-particle interaction the above equation for the field operator $\Psi(\mathbf{r}', t)$ is identical to the single-particle Schrödinger equation for the single particle wavefunction $\psi(\mathbf{r}')$. Due to this similarity the many-particle formalism of quantum mechanics is sometimes called second quantization.

Solution 16.6.1. The Heisenberg equation of motion [see Eq. (4.37)] is given by

$$i\hbar \frac{d\Psi}{dt} = -[\mathcal{H}, \Psi]_- . \quad (16.69)$$

For general operators A , B and C the following holds

$$\begin{aligned}
 [AB, C]_{\pm} &= A[B, C]_{\pm} \mp [A, C]_{\pm} B \\
 &= A[B, C]_{\pm} - [C, A]_{\pm} B .
 \end{aligned}
 \tag{16.70}$$

Below we employ this relation for evaluating commutation relations. For Fermions the upper sign (anti-commutation) is chosen, whereas for Bosons the lower one is chosen (commutation). With the help of Eqs. (16.40), (16.41) and (16.42) one finds (for both Bosons and for Fermions) that

$$\begin{aligned}
 [T, \Psi(\mathbf{r}')]_{-} &= -\frac{\hbar^2}{2m} \int d^3\mathbf{r}'' [\Psi^{\dagger}(\mathbf{r}'') \nabla^2 \Psi(\mathbf{r}'') , \Psi(\mathbf{r}')]_{-} \\
 &= \frac{\hbar^2}{2m} \int d^3\mathbf{r}'' \delta(\mathbf{r}' - \mathbf{r}'') \nabla^2 \Psi(\mathbf{r}'') \\
 &= \frac{\hbar^2}{2m} \nabla^2 \Psi(\mathbf{r}') ,
 \end{aligned}
 \tag{16.71}$$

and

$$\begin{aligned}
 [U, \Psi(\mathbf{r}')]_{-} &= \int d^3\mathbf{r}'' U_{\text{SP}}(\mathbf{r}'') [\Psi^{\dagger}(\mathbf{r}'') \Psi(\mathbf{r}'') , \Psi(\mathbf{r}')]_{-} \\
 &= - \int d^3\mathbf{r}'' U_{\text{SP}}(\mathbf{r}'') \delta(\mathbf{r}' - \mathbf{r}'') \Psi(\mathbf{r}'') \\
 &= -U_{\text{SP}}(\mathbf{r}') \Psi(\mathbf{r}') .
 \end{aligned}
 \tag{16.72}$$

$$\tag{16.73}$$

Similarly

$$\begin{aligned}
 &[V, \Psi(\mathbf{r}')]_{-} \\
 &= \frac{1}{2} \int d^3\mathbf{r}'' \int d^3\mathbf{r}''' V_{\text{TP}}(\mathbf{r}'', \mathbf{r}''') [\Psi^{\dagger}(\mathbf{r}'') \Psi^{\dagger}(\mathbf{r}''') \Psi(\mathbf{r}''') \Psi(\mathbf{r}'') , \Psi(\mathbf{r}')]_{-} \\
 &= \frac{1}{2} \int d^3\mathbf{r}'' \int d^3\mathbf{r}''' V_{\text{TP}}(\mathbf{r}'', \mathbf{r}''') [\Psi^{\dagger}(\mathbf{r}'') \Psi^{\dagger}(\mathbf{r}''') , \Psi(\mathbf{r}')]_{-} \Psi(\mathbf{r}''') \Psi(\mathbf{r}'') \\
 &= -\frac{1}{2} \int d^3\mathbf{r}'' \int d^3\mathbf{r}''' V_{\text{TP}}(\mathbf{r}'', \mathbf{r}''') \Psi^{\dagger}(\mathbf{r}'') \delta(\mathbf{r}' - \mathbf{r}''') \Psi(\mathbf{r}''') \Psi(\mathbf{r}'') \\
 &\quad -\frac{1}{2} \int d^3\mathbf{r}'' \int d^3\mathbf{r}''' V_{\text{TP}}(\mathbf{r}'', \mathbf{r}''') \delta(\mathbf{r}' - \mathbf{r}'') \Psi^{\dagger}(\mathbf{r}''') \Psi(\mathbf{r}''') \Psi(\mathbf{r}'') \\
 &= - \int d^3\mathbf{r}'' V_{\text{TP}}(\mathbf{r}', \mathbf{r}'') \Psi^{\dagger}(\mathbf{r}'') \Psi(\mathbf{r}'') \Psi(\mathbf{r}')
 \end{aligned}
 \tag{16.74}$$

where in the last step it was assumed that $V_{\text{TP}}(\mathbf{r}'', \mathbf{r}') = V_{\text{TP}}(\mathbf{r}', \mathbf{r}'')$. Combining these results lead to Eq. (16.68).

16.7 Momentum Representation

In the momentum representation the Hamiltonian is constructed using a single-particle basis made of momentum eigenvectors $|\mathbf{p}'\rangle$. The wavefunctions of these single-particle states are proportional to $e^{i\mathbf{k}'\cdot\mathbf{r}'}$ [see Eq. (3.75)], where

$$\mathbf{k}' = \frac{\mathbf{p}'}{\hbar} . \quad (16.75)$$

These wavefunctions can be normalized when the volume of the system is taken to be finite. For simplicity, consider the case where the particles are confined within a volume $\mathcal{V} = L^3$ having a cubic shape. The normalized wavefunctions are taken to be given by

$$\langle \mathbf{r}' | \mathbf{k}' \rangle = \psi_{\mathbf{k}'}(\mathbf{r}') = \frac{1}{\sqrt{\mathcal{V}}} e^{i\mathbf{k}'\cdot\mathbf{r}'} , \quad (16.76)$$

where $|\mathbf{k}'\rangle$ labels a momentum eigenvector having an eigenvalue $\hbar\mathbf{k}'$. The requirement that the wavefunctions $\psi_{\mathbf{k}'}(\mathbf{r}')$ satisfy periodic boundary conditions, i.e. $\psi_{\mathbf{k}}(\mathbf{r}') = \psi_{\mathbf{k}}(\mathbf{r}' + L\hat{\mathbf{x}}) = \psi_{\mathbf{k}}(\mathbf{r}' + L\hat{\mathbf{y}}) = \psi_{\mathbf{k}}(\mathbf{r}' + L\hat{\mathbf{z}})$, yields a discrete set of allowed values of the wave vector \mathbf{k}

$$\mathbf{k} = \frac{2\pi}{L} (n_x, n_y, n_z) , \quad (16.77)$$

where n_x , n_y and n_z are all integers. The orthonormality condition reads

$$\begin{aligned} \int_{\mathcal{V}} d^3\mathbf{r}' \psi_{\mathbf{k}''}^*(\mathbf{r}') \psi_{\mathbf{k}'}(\mathbf{r}') &= \frac{1}{\mathcal{V}} \int_{\mathcal{V}} d^3\mathbf{r}' e^{i(\mathbf{k}' - \mathbf{k}'')\cdot\mathbf{r}'} \\ &= \delta_{\mathbf{k}', \mathbf{k}''} . \end{aligned} \quad (16.78)$$

In the momentum representation the many-particle kinetic energy T is given by [see Eq. (16.60)]

$$\begin{aligned} T &= \frac{1}{2m} \sum_{\mathbf{k}', \mathbf{k}''} \langle \mathbf{k}'' | \mathbf{p}_{\text{SP}}^2 | \mathbf{k}' \rangle a_{\mathbf{k}''}^\dagger a_{\mathbf{k}'} \\ &= \frac{\hbar^2}{2m} \sum_{\mathbf{k}'} \mathbf{k}'^2 a_{\mathbf{k}'}^\dagger a_{\mathbf{k}'} , \end{aligned} \quad (16.79)$$

the many-particle potential energy U is given by [see Eq. (16.64)]

$$U = \sum_{\mathbf{k}', \mathbf{k}''} U_{\mathbf{k}' - \mathbf{k}''} a_{\mathbf{k}''}^\dagger a_{\mathbf{k}'} , \quad (16.80)$$

where

$$\begin{aligned}
 U_{\mathbf{k}'-\mathbf{k}''} &= \langle \mathbf{k}'' | U_{\text{SP}}(\mathbf{r}') | \mathbf{k}' \rangle \\
 &= \frac{1}{\mathcal{V}} \int_{\mathcal{V}} d^3\mathbf{r}' U_{\text{SP}}(\mathbf{r}') e^{i(\mathbf{k}'-\mathbf{k}'')\cdot\mathbf{r}'} ,
 \end{aligned} \tag{16.81}$$

and the many-particle interaction operator is given by [see Eq. (16.57)]

$$V = \frac{1}{2} \sum_{\mathbf{k}', \mathbf{k}'', \mathbf{k}''', \mathbf{k}''''} \langle \mathbf{k}', \mathbf{k}'' | V_{\text{TP}} | \mathbf{k}''', \mathbf{k}'''' \rangle a_{\mathbf{k}'}^\dagger a_{\mathbf{k}''}^\dagger a_{\mathbf{k}''''} a_{\mathbf{k}'''} , \tag{16.82}$$

where

$$\langle \mathbf{k}', \mathbf{k}'' | V_{\text{TP}} | \mathbf{k}''', \mathbf{k}'''' \rangle = \frac{1}{\mathcal{V}^2} \int_{\mathcal{V}} d^3\mathbf{r}' \int_{\mathcal{V}} d^3\mathbf{r}'' V_{\text{TP}}(\mathbf{r}', \mathbf{r}'') e^{i(\mathbf{k}''''-\mathbf{k}')\cdot\mathbf{r}'} e^{i(\mathbf{k}''-\mathbf{k}'')\cdot\mathbf{r}''} . \tag{16.83}$$

The assumption that $V_{\text{TP}}(\mathbf{r}', \mathbf{r}'')$ is a function of the relative coordinate $\mathbf{r} = \mathbf{r}' - \mathbf{r}''$ only, together with the coordinates transformation

$$\mathbf{r}_0 = \frac{\mathbf{r}' + \mathbf{r}''}{2} , \tag{16.84}$$

$$\mathbf{r} = \mathbf{r}' - \mathbf{r}'' , \tag{16.85}$$

yields (note that $\mathbf{r}' = \mathbf{r}_0 + \mathbf{r}/2$ and $\mathbf{r}'' = \mathbf{r}_0 - \mathbf{r}/2$)

$$\begin{aligned}
 &\langle \mathbf{k}', \mathbf{k}'' | V_{\text{TP}} | \mathbf{k}''', \mathbf{k}'''' \rangle \\
 &= \frac{1}{\mathcal{V}^2} \int_{\mathcal{V}} d^3\mathbf{r}_0 e^{i(\mathbf{k}''''-\mathbf{k}'+\mathbf{k}''-\mathbf{k}''')\cdot\mathbf{r}_0} \int_{\mathcal{V}} d^3\mathbf{r} V_{\text{TP}}(\mathbf{r}_0 + \mathbf{r}/2, \mathbf{r}_0 - \mathbf{r}/2) e^{\frac{i(\mathbf{k}''''-\mathbf{k}'-\mathbf{k}'''+\mathbf{k}'')\cdot\mathbf{r}}{2}} \\
 &= \delta_{\mathbf{k}'+\mathbf{k}'', \mathbf{k}'''+\mathbf{k}''''} \frac{1}{\mathcal{V}} \int_{\mathcal{V}} d^3\mathbf{r} v_{\text{TP}}(\mathbf{r}) e^{\frac{i(\mathbf{k}''''-\mathbf{k}'-\mathbf{k}'''+\mathbf{k}'')\cdot\mathbf{r}}{2}} ,
 \end{aligned} \tag{16.86}$$

where

$$v_{\text{TP}}(\mathbf{r}) = V_{\text{TP}}(\mathbf{r}_0 + \mathbf{r}/2, \mathbf{r}_0 - \mathbf{r}/2) . \tag{16.87}$$

Thus the only allowed processes for this case are those for which the total momentum is conserved, i.e. $\mathbf{k}' + \mathbf{k}'' = \mathbf{k}''' + \mathbf{k}''''$. Using the notation

$$\mathbf{q} = \mathbf{k}'' - \mathbf{k}''' = \mathbf{k}'''' - \mathbf{k}' , \tag{16.88}$$

one can express V as

$$V = \frac{1}{2} \sum_{\mathbf{k}', \mathbf{k}'', \mathbf{q}} v_{\mathbf{q}} a_{\mathbf{k}'}^\dagger a_{\mathbf{k}''}^\dagger a_{\mathbf{k}''-\mathbf{q}} a_{\mathbf{k}'+\mathbf{q}} , \tag{16.89}$$

where

$$v_{\mathbf{q}} = \frac{1}{\mathcal{V}} \int_{\mathcal{V}} d^3\mathbf{r} v_{\text{TP}}(\mathbf{r}) e^{\frac{i\mathbf{q}\cdot\mathbf{r}}{2}} . \tag{16.90}$$

16.8 Spin

In addition to spatial (orbital) degrees of freedom, the particles may have spin. We demonstrate below the inclusion of spin for the case of momentum representation. The basis for single-particle states is taken to be $\{|\mathbf{k}', \sigma'\rangle\}_{\mathbf{k}', \sigma'}$, where the quantum number σ indicates the spin state. The single-particle orthonormality condition reads

$$\langle \mathbf{k}'', \sigma'' | \mathbf{k}', \sigma' \rangle = \delta_{\mathbf{k}', \mathbf{k}''} \delta_{\sigma', \sigma''} . \quad (16.91)$$

The commutation (for Bosons) and anti-commutation (for Fermions) relations [see Eqs. (16.6), (16.7), (16.8) and (16.9)] become

$$[a_{\mathbf{k}', \sigma'}, a_{\mathbf{k}'', \sigma''}]_{\pm} = [a_{\mathbf{k}', \sigma'}^{\dagger}, a_{\mathbf{k}'', \sigma''}^{\dagger}]_{\pm} = 0 , \quad (16.92)$$

$$[a_{\mathbf{k}', \sigma'}, a_{\mathbf{k}'', \sigma''}^{\dagger}]_{\pm} = \delta_{\mathbf{k}', \mathbf{k}''} \delta_{\sigma', \sigma''} , \quad (16.93)$$

For the example above, the Hamiltonian becomes

$$\begin{aligned} \mathcal{H} &= \frac{\hbar^2}{2m} \sum_{\mathbf{k}', \sigma'} \mathbf{k}'^2 a_{\mathbf{k}', \sigma'}^{\dagger} a_{\mathbf{k}', \sigma'} + \sum_{\mathbf{k}', \mathbf{k}'', \sigma'} U_{\mathbf{k}' - \mathbf{k}''} a_{\mathbf{k}'', \sigma'}^{\dagger} a_{\mathbf{k}', \sigma'} \\ &\quad + \frac{1}{2} \sum_{\mathbf{k}', \mathbf{k}'', \mathbf{q}, \sigma', \sigma''} v_{\mathbf{q}} a_{\mathbf{k}', \sigma'}^{\dagger} a_{\mathbf{k}'', \sigma''}^{\dagger} a_{\mathbf{k}'' - \mathbf{q}, \sigma''} a_{\mathbf{k}' + \mathbf{q}, \sigma'} . \end{aligned} \quad (16.94)$$

16.9 The Electron Gas

Consider a free (i.e. noninteracting) gas of $N \gg 1$ electrons occupying volume \mathcal{V} . The Hamiltonian is given by [see Eq. (16.94)]

$$\mathcal{H} = \frac{\hbar^2}{2m} \sum_{\mathbf{k}', \sigma'} \mathbf{k}'^2 a_{\mathbf{k}', \sigma'}^{\dagger} a_{\mathbf{k}', \sigma'} . \quad (16.95)$$

In the momentum representation the single particle state $|\mathbf{k}', \sigma\rangle$ has a wavefunction given by [see Eq. (16.76)]

$$\langle \mathbf{r}' | \mathbf{k}', \sigma \rangle = \frac{1}{\sqrt{\mathcal{V}}} e^{i\mathbf{k}' \cdot \mathbf{r}'} , \quad (16.96)$$

and thus the quantized field operator $\Psi_{\sigma}(\mathbf{r}')$ is given by [see Eq. (16.38)]

$$\Psi_{\sigma}(\mathbf{r}') = \frac{1}{\sqrt{\mathcal{V}}} \sum_{\mathbf{k}'} e^{i\mathbf{k}' \cdot \mathbf{r}'} a_{\mathbf{k}', \sigma} . \quad (16.97)$$

The single particle state $|\mathbf{k}', \sigma\rangle$ has energy given by

$$\epsilon_{k'} = \frac{\hbar^2 k'^2}{2m}, \quad (16.98)$$

where m is the electron mass [see Eq. (16.95)].

The allowed values of \mathbf{k}' are determined by boundary conditions. Consider for simplicity the case where the gas is confined in a cube (having edge length of $\mathcal{V}^{1/3}$). Imposing periodic boundary conditions on the wavefunction of the single particle states $|\mathbf{k}', \sigma\rangle$ leads to the requirement (16.77). Thus, the density of states per spin in \mathbf{k}' space is $\mathcal{V}/8\pi^3$.

In the ground state $|\varphi_0\rangle$ all single particle states for which $|\mathbf{k}'| \leq k_F$ are singly occupied, whereas all single particle states for which $|\mathbf{k}'| > k_F$ remain empty, i.e.

$$|\varphi_0\rangle = \prod_{|\mathbf{k}'| \leq k_F, \sigma'} a_{\mathbf{k}', \sigma'}^\dagger |0\rangle. \quad (16.99)$$

The Fermi wave vector is chosen such that the number of single particle states for which $|\mathbf{k}'| \leq k_F$ is N . Since the density of states per spin in \mathbf{k}' space is $\mathcal{V}/8\pi^3$ one finds that

$$2 \frac{\mathcal{V}}{8\pi^3} \frac{4}{3} \pi k_F^3 = N, \quad (16.100)$$

thus

$$k_F^3 = \frac{3\pi^2 N}{\mathcal{V}}. \quad (16.101)$$

The Fermi energy ϵ_F is the corresponding energy

$$\epsilon_F = \frac{\hbar^2 k_F^2}{2m}. \quad (16.102)$$

The density of states $D(\epsilon)$ per spin and per unit volume is given by

$$D(\epsilon) = \frac{1}{\mathcal{V}} \sum_{\mathbf{k}'} \delta(\epsilon - \epsilon_{\mathbf{k}'}). \quad (16.103)$$

where $\epsilon_{\mathbf{k}'}$ is given by Eq. (16.98). By replacing the sum by an integral one finds that

$$\begin{aligned} D(\epsilon) &= \frac{1}{\mathcal{V}} \sum_{\mathbf{k}'} \delta\left(\epsilon - \frac{\hbar^2 k'^2}{2m}\right) \\ &= \frac{1}{\mathcal{V}} \frac{\mathcal{V}}{8\pi^3} 4\pi \int_0^\infty dk' k'^2 \delta\left(\epsilon - \frac{\hbar^2 k'^2}{2m}\right) \\ &= \frac{1}{4\pi^2} \left(\frac{2m}{\hbar^2}\right)^{3/2} \int_0^\infty d\epsilon' \sqrt{\epsilon'} \delta(\epsilon - \epsilon') \\ &= \frac{m}{2\pi^2 \hbar^3} \sqrt{2m\epsilon}. \end{aligned} \quad (16.104)$$

The ground state energy is given by

$$E_0 = 2\mathcal{V} \int_0^{\epsilon_F} d\epsilon' D(\epsilon') \epsilon' = \frac{2^{3/2} m^{3/2} \mathcal{V} \epsilon_F^{5/2}}{5\pi^2 \hbar^3}, \quad (16.105)$$

or [see Eq. (16.101) and (16.102)]

$$E_0 = \frac{3N}{5} \frac{\hbar^2 k_F^2}{2m}. \quad (16.106)$$

16.10 Problems

1. Find the many-particle interaction operator V for the case where the two-particle potential is a constant $V_{\text{TP}}(\mathbf{r}_1, \mathbf{r}_2) = V_0$.
2. The same for the Coulomb interaction

$$V_{\text{TP}}(\mathbf{r}_1, \mathbf{r}_2) = \frac{e^2}{|\mathbf{r}_1 - \mathbf{r}_2|}. \quad (16.107)$$

3. Show that

$$\frac{d\rho}{dt} + \nabla \mathbf{J} = 0, \quad (16.108)$$

where $\rho(\mathbf{r}') = \Psi^\dagger(\mathbf{r}') \Psi(\mathbf{r}')$ is the number density operator [see Eq. (16.44)] and where the current density operator \mathbf{J} is given by

$$\mathbf{J}(\mathbf{r}') = \frac{\hbar}{2im} [\Psi^\dagger(\mathbf{r}') \nabla \Psi(\mathbf{r}') - (\nabla \Psi^\dagger(\mathbf{r}')) \Psi(\mathbf{r}')] . \quad (16.109)$$

4. Consider N identical fermions having mass m occupying a one-dimensional potential well $U(x')$ of width l given by

$$U(x') = \begin{cases} 0 & \text{if } 0 \leq x' \leq l \\ \infty & \text{else} \end{cases}. \quad (16.110)$$

All fermions are in the same spin state, so spin can be disregarded. The average density is denoted by $\rho_0 = N/l$. Calculate the expectation value $\langle \rho(x') \rangle$ of the number density operator $\rho(x')$ at position x' at zero temperature, for a given average density ρ_0 , and in the limit where $N \rightarrow \infty$ and $l \rightarrow \infty$.

5. Consider two identical Bosons having mass m in a one-dimensional potential $U(x)$ well given by

$$U(x) = \begin{cases} 0 & \text{if } 0 \leq x \leq L \\ \infty & \text{else} \end{cases}. \quad (16.111)$$

The particles interact with each other via a two-particle interaction given by $V_{\text{TP}} = -V_0 L \delta(x_1 - x_2)$, where V_0 is a constant. Calculate the ground state energy to lowest nonvanishing order in V_0 .

6. By definition, an ideal gas is an ensemble of non-interacting identical particles. The set of single particle eigenenergies is denoted by $\{\varepsilon_i\}$. Calculate the average energy $\langle \mathcal{H} \rangle$ and the average number of particles $\langle N \rangle$ in thermal equilibrium as a function of the temperature T and the chemical potential μ for the case of
- Fermions.
 - Bosons.
7. **Bogoliubov transformation** - Consider the transformation

$$b_{\mathbf{k}} = u_{\mathbf{k}} a_{\mathbf{k}} + v_{\mathbf{k}} a_{-\mathbf{k}}^{\dagger}, \quad (16.112)$$

where $a_{\mathbf{k}}$ ($a_{-\mathbf{k}}^{\dagger}$) is the annihilation (creation) operator corresponding to the single particle state $|\mathbf{k}\rangle$ ($|\mathbf{-k}\rangle$), and where $u_{\mathbf{k}}$ and $v_{\mathbf{k}}$ are real coefficients. The state $|V_b\rangle$ is defined by the condition

$$b_{\mathbf{k}} |V_b\rangle = 0. \quad (16.113)$$

- For the case of Fermions, under what conditions the operators $b_{\mathbf{k}}$ and $b_{\mathbf{k}}^{\dagger}$ can be considered as annihilation and creation operators? Evaluate the expectation value $\langle V_b | a_{\mathbf{k}}^{\dagger} a_{\mathbf{k}} | V_b \rangle$.
 - The same for Bosons.
8. Find the eigenenergies of the Hamiltonian

$$\mathcal{H} = \sum_{\mathbf{k}'} \epsilon_{\mathbf{k}'} \left[a_{\mathbf{k}'}^{\dagger} a_{\mathbf{k}'} + \lambda \left(a_{\mathbf{k}'} + a_{\mathbf{k}'}^{\dagger} \right) \right], \quad (16.114)$$

where $a_{\mathbf{k}'}$ and $a_{\mathbf{k}'}^{\dagger}$ are Boson annihilation and creation operators corresponding to the single particle state $|\mathbf{k}'\rangle$, and where $\epsilon_{\mathbf{k}'}$ and λ are real coefficients.

9. Consider a system of identical spinless Bosons, whose Hamiltonian is given by

$$\mathcal{H} = \sum_{\mathbf{k}'} \epsilon_{\mathbf{k}'} a_{\mathbf{k}'}^{\dagger} a_{\mathbf{k}'} + \sum_{\mathbf{k}'} \frac{\xi_{\mathbf{k}'}}{2} \left(2a_{\mathbf{k}'}^{\dagger} a_{\mathbf{k}'} + a_{\mathbf{k}'}^{\dagger} a_{-\mathbf{k}'}^{\dagger} + a_{\mathbf{k}'} a_{-\mathbf{k}'} \right), \quad (16.115)$$

where summation is over momentum single particle states having wave vector \mathbf{k}' , and $a_{\mathbf{k}'}$ and $a_{\mathbf{k}'}^{\dagger}$ are annihilation and creation operators, respectively. The coefficients $\epsilon_{\mathbf{k}'}$ and $\xi_{\mathbf{k}'}$ are assumed to be even functions of \mathbf{k}' , i.e. $\epsilon_{-\mathbf{k}'} = \epsilon_{\mathbf{k}'}$ and $\xi_{-\mathbf{k}'} = \xi_{\mathbf{k}'}$. Calculate the eigenenergies of \mathcal{H} .

10. **Bose-Einstein condensate** - Consider a free (i.e. noninteracting) gas made of identical Bosons having each mass m . The gas has temperature T and volume V . The total number of particles is expressed as $N = N_0 + N_e$, where N_0 is the number of particles occupying the ground state, which has a vanishing wave vector $\mathbf{k} = 0$, and where N_e is the number of particles occupying the excited states having $|\mathbf{k}| > 0$. Calculate the ratio $n_0 = N_0/V$ in the thermodynamical limit where $N \gg 1$. Express the result as a function of the temperature T and density $n = N/V$.

11. **Gross-Pitaevskii equation** - Consider a weakly interacting Bose gas. The temperature is assumed to be well below the critical value corresponding to the Bose-Einstein condensation [see Eq. (16.226)]. In the mean-field approximation the quantized field operator $\Psi(\mathbf{r}', t)$ [see Eq. (16.38)] is expressed as

$$\Psi(\mathbf{r}', t) = \Phi(\mathbf{r}', t) + \Psi'(\mathbf{r}', t) , \quad (16.116)$$

where $\Phi(\mathbf{r}', t) = \langle \Psi(\mathbf{r}', t) \rangle$, and it is assumed that $|\Phi(\mathbf{r}', t)|^2 = n_0(\mathbf{r}', t)$, where n_0 is the density of particles occupying the ground state (having a vanishing wave vector $\mathbf{k} = 0$). Consider the case where the two-particle interaction $V_{\text{TP}}(\mathbf{r}', \mathbf{r}'')$ in Eq. (16.68) is given by

$$V_{\text{TP}}(\mathbf{r}', \mathbf{r}'') = g\delta(\mathbf{r}' - \mathbf{r}'') , \quad (16.117)$$

where the interaction coefficient g is assumed to be a constant. Show that under these assumptions, when $\Psi'(\mathbf{r}', t)$ is disregarded, Eq. (16.68) yields

$$i\hbar \frac{d}{dt} \Phi(\mathbf{r}', t) = \left(-\frac{\hbar^2}{2m} \nabla^2 + U_{\text{SP}}(\mathbf{r}') + g|\Phi(\mathbf{r}', t)|^2 \right) \Phi(\mathbf{r}', t) . \quad (16.118)$$

12. **Hong-Ou-Mandel bunching effect** - Consider a beam splitter, which couples four modes of identical Bosons, which are labelled as A_1 , A_2 , B_1 and B_2 . Let a_1 , a_2 , b_1 and b_2 be annihilation operators corresponding to the modes A_1 , A_2 , B_1 and B_2 , respectively. It is assumed that

$$\begin{pmatrix} b_1 \\ b_2 \end{pmatrix} = S \begin{pmatrix} a_1 \\ a_2 \end{pmatrix} , \quad (16.119)$$

where the scattering matrix S is given by

$$S = \begin{pmatrix} t & r \\ r' & t' \end{pmatrix} , \quad (16.120)$$

and where t , r , t' and r' are complex constants.

- a) Show that the Bosonic commutation relations $[a_n, a_m^\dagger] = \delta_{n,m}$ and

$$[b_n, b_m^\dagger] = \delta_{n,m} \text{ imply that } |r|^2 + |t|^2 = |r'|^2 + |t'|^2 = 1 , \quad (16.121)$$

$$r't^* + r'^*t' = 0 . \quad (16.122)$$

- b) Consider an initial state having a single photon in input mode A_1 and a single photon in input mode A_2 . Express the output state in terms of the creation operators b_1^\dagger and b_2^\dagger , and calculate the probability p_{11} to find two photons in output mode B_1 , the probability p_{22} to find two photons in output mode B_2 , and the probability p_{12} to find a single photon in output mode B_1 and a single photon in output mode B_2 .

13. Find eigenvectors and eigenvalues of the quantized field operator $\Psi(\mathbf{r})$ for the case of Bosons. Evaluate the expectation values with respect to the number operator N and with respect with the Hamiltonian of the many body system (with one-particle and two-particle interactions).
14. Consider a neutral helium atom having 2 electrons and a nucleus having charge $+2e$. Calculate the energy of the ground state. Assume that the Coulomb interaction between the electrons can be considered as small and calculate the energy correction due to this interaction to lowest non-vanishing order in perturbation theory. Ignore spin-orbit coupling and hyperfine interaction.
15. Consider the state

$$|\gamma\rangle = \int d\mathbf{r}' \int d\mathbf{r}'' F(\mathbf{r}', \mathbf{r}'') \Psi^\dagger(\mathbf{r}') \Psi^\dagger(\mathbf{r}'') |0\rangle, \quad (16.123)$$

where $\Psi(\mathbf{r}')$ is the Bosonic quantized field operator, $|0\rangle$ represents the state where all occupation numbers are zero, and $F(\mathbf{r}', \mathbf{r}'')$ is complex.

- a) Find a condition that the function $F(\mathbf{r}', \mathbf{r}'')$ must satisfy in order to ensure that the state $|\gamma\rangle$ is normalized.
- b) Consider the case where $F(\mathbf{r}', \mathbf{r}'')$ can be expressed as $F(\mathbf{r}', \mathbf{r}'') = Af_1(\mathbf{r}')f_2(\mathbf{r}'')$, where A is a normalization constant (which is chosen such that $\langle\gamma|\gamma\rangle = 1$) and where both functions $f_1()$ and $f_2()$ are normalized according to

$$1 = \int d\mathbf{r}' |f_1(\mathbf{r}')|^2 = \int d\mathbf{r}' |f_2(\mathbf{r}')|^2.$$

Evaluate the function

$$g(\mathbf{r}') = \langle\gamma|\rho(\mathbf{r}')|\gamma\rangle, \quad (16.124)$$

where $\rho(\mathbf{r}') = \Psi^\dagger(\mathbf{r}')\Psi(\mathbf{r}')$.

- c) Calculate the total number of particles

$$N_\gamma = \int d\mathbf{r}' g(\mathbf{r}'). \quad (16.125)$$

16. Consider a free (i.e. noninteracting) gas of $N \gg 1$ electrons occupying volume \mathcal{V} . Calculate the correlation function

$$C_\sigma(\mathbf{r}' - \mathbf{r}'') = \langle\varphi_0|\Psi_\sigma^\dagger(\mathbf{r}')\Psi_\sigma(\mathbf{r}'')|\varphi_0\rangle, \quad (16.126)$$

where $|\varphi_0\rangle$ is the ground state of the N electrons gas, $\Psi_\sigma(\mathbf{r})$ is the quantized field operator and σ stands for a spin state.

17. Calculate the ground state energy of electron gas containing $N \gg 1$ electrons filling a volume \mathcal{V} . Consider the Coulomb interaction between electrons as weak and calculate the energy shift due to this interaction to

lowest non-vanishing order in perturbation theory. Assume that the volume \mathcal{V} contains a uniform background of positive charge density $+eN/\mathcal{V}$ (without the positive background the system is expected to be unstable due to the repulsive nature of the Coulomb interaction).

18. Calculate the entropy of a free electron gas to lowest nonvanishing order in the temperature T .
19. Let $D_d(\epsilon)$ be the energy density of states per spin and per unit volume of an electron gas in a d -dimensional space. Generalize Eq. (16.104), which states that, $D_{d=3}(\epsilon) = m\sqrt{2m\epsilon}/(2\pi^2\hbar^3)$, for a general positive integer d .

16.11 Solutions

1. In general V is given by Eq. (16.89) where for this case

$$v_{\mathbf{q}} = V_0 \delta_{\mathbf{q},0} , \quad (16.127)$$

thus

$$\begin{aligned} V &= \frac{V_0}{2} \sum_{\mathbf{k}', \mathbf{k}''} a_{\mathbf{k}'}^\dagger a_{\mathbf{k}''}^\dagger a_{\mathbf{k}''} a_{\mathbf{k}'} \\ &= \frac{V_0}{2} \sum_{\mathbf{k}', \mathbf{k}''} a_{\mathbf{k}'}^\dagger \left(\left[a_{\mathbf{k}'', a_{\mathbf{k}''}}^\dagger, a_{\mathbf{k}'} \right]_{-} + a_{\mathbf{k}'} a_{\mathbf{k}''}^\dagger a_{\mathbf{k}''} \right) . \end{aligned} \quad (16.128)$$

With the help of Eq. (16.70) one finds that [see also Eqs. (16.6), (16.7), (16.8) and (16.9)]

$$\begin{aligned} \left[a_{\mathbf{k}'', a_{\mathbf{k}''}}^\dagger, a_{\mathbf{k}'} \right]_{-} &= a_{\mathbf{k}''}^\dagger \left[a_{\mathbf{k}'', a_{\mathbf{k}''}}^\dagger, a_{\mathbf{k}'} \right]_{\pm} - \left[a_{\mathbf{k}'}, a_{\mathbf{k}''}^\dagger \right]_{\pm} a_{\mathbf{k}''} \\ &= -\delta_{\mathbf{k}', \mathbf{k}''} a_{\mathbf{k}'} , \end{aligned} \quad (16.129)$$

[for Fermions the upper sign (anti-commutation) is taken, whereas for Bosons the lower one is taken (commutation)], thus

$$V = V_0 \frac{N(N-1)}{2} , \quad (16.130)$$

where N is the total number of particles operator. Note that $N(N-1)/2$ is the number of interacting pairs in the system.

2. For this case the Fourier transform $f(\mathbf{q})$ of the function $1/|\mathbf{r}|$ is needed

$$\frac{1}{|\mathbf{r}|} = \int d^3\mathbf{q} f(\mathbf{q}) e^{i\mathbf{q}\cdot\mathbf{r}} . \quad (16.131)$$

Applying the Laplace operator ∇^2 and using the identity

$$\nabla^2 \frac{1}{|\mathbf{r}|} = -4\pi\delta(\mathbf{r}) \quad (16.132)$$

yield

$$-4\pi\delta(\mathbf{r}) = - \int d^3\mathbf{q} f(\mathbf{q}) |\mathbf{q}|^2 e^{i\mathbf{q}\cdot\mathbf{r}} , \quad (16.133)$$

thus with the help of the identity

$$\int_{-\infty}^{\infty} dk e^{ikx} = 2\pi\delta(x) , \quad (16.134)$$

one finds that

$$f(\mathbf{q}) = \frac{1}{2\pi^2 q^2} , \quad (16.135)$$

where $q = |\mathbf{q}|$, and therefore

$$\frac{1}{|\mathbf{r}|} = \frac{1}{2\pi^2} \int d^3\mathbf{q} \frac{1}{q^2} e^{i\mathbf{q}\cdot\mathbf{r}} \quad (16.136)$$

With the help of this result one finds that V is given by [see Eqs. (16.89) and (16.90)]

$$V = \frac{1}{2\mathcal{V}} \sum_{\mathbf{k}', \mathbf{k}'', \mathbf{q}} \frac{4\pi e^2}{q^2} a_{\mathbf{k}'}^\dagger a_{\mathbf{k}''}^\dagger a_{\mathbf{k}'' - \mathbf{q}} a_{\mathbf{k}' + \mathbf{q}} . \quad (16.137)$$

3. With the help of Eq. (16.68) and its Hermitian conjugate one finds that

$$\begin{aligned} \frac{d\rho}{dt} &= \frac{d\Psi^\dagger(\mathbf{r}')}{dt} \Psi(\mathbf{r}') + \Psi^\dagger(\mathbf{r}') \frac{d\Psi(\mathbf{r}')}{dt} \\ &= -\frac{1}{i\hbar} \frac{\hbar^2}{2m} [\Psi^\dagger(\mathbf{r}') \nabla^2 \Psi(\mathbf{r}', t) - (\nabla^2 \Psi^\dagger(\mathbf{r}', t)) \Psi(\mathbf{r}')] , \end{aligned} \quad (16.138)$$

where the assumptions $U_{\text{SP}}^*(\mathbf{r}') = U_{\text{SP}}(\mathbf{r}')$ and $V_{\text{TP}}^*(\mathbf{r}', \mathbf{r}'') = V_{\text{TP}}(\mathbf{r}', \mathbf{r}'')$ have been made, thus

$$\frac{d\rho}{dt} + \nabla \mathbf{J} = 0 . \quad (16.139)$$

Note the similarity between this result and the continuity equation that is satisfied by a single-particle wavefunction [see Eq. (4.81)].

4. At zero temperature the N lowest energy states are occupied, and all higher states are empty. With the help of Eqs. (16.37), (16.38) and (16.44), together with Eq. (9.186), one finds that

$$\langle \rho(x') \rangle = \sum_{n=1}^N |\psi_n(x')|^2 = \frac{2}{l} \sum_{n=1}^N \sin^2 \frac{n\pi x'}{l} .$$

In the limit where $l \rightarrow \infty$ the sum can be replaced by an integral

$$\begin{aligned} \langle \rho(x') \rangle &= \frac{2}{l} \int_0^N dn \sin^2 \frac{n\pi x'}{l} \\ &= \rho_0 \left(1 - \frac{\sin(2\pi\rho_0 x')}{2\pi\rho_0 x'} \right) . \end{aligned}$$

Alternatively,

$$\begin{aligned} \langle \rho(x') \rangle &= \frac{2}{l} \sum_{n=1}^N \sin^2 \frac{n\pi x'}{l} \\ &= \frac{1}{l} \sum_{n=1}^N \left(1 - \cos \frac{2n\pi x'}{l} \right) \\ &= \frac{1}{l} \operatorname{Re} \sum_{n=1}^N \left(1 - e^{\frac{2ni\pi x'}{l}} \right) \\ &= \rho_0 \left(1 + \frac{1}{\rho_0} \operatorname{Re} \frac{1 - e^{2i\pi\rho_0 x'}}{l \left(1 - e^{-\frac{2i\pi x'}{l}} \right)} \right) , \end{aligned} \tag{16.140}$$

thus in the limit $l \rightarrow \infty$

$$\langle \rho(x') \rangle = \rho_0 \left(1 - \frac{\sin(2\pi\rho_0 x')}{2\pi\rho_0 x'} \right) . \tag{16.141}$$

5. For the unperturbed case, i.e. when $V_0 = 0$, the single-particle wavefunctions of the normalized eigenstates are given by

$$\psi_j(x) = \sqrt{\frac{2}{L}} \sin \frac{j\pi x}{L} , \tag{16.142}$$

where $j = 1, 2, \dots$, and the corresponding single-particle eigenenergies are

$$\varepsilon_j = \frac{\hbar^2 \pi^2 j^2}{2mL^2} . \tag{16.143}$$

For this case the ground state is the many-particle state $|\text{GS}\rangle = |n_1 = 2, n_2 = 0, n_3 = 0, \dots\rangle$, i.e. the state for which both particles are in the $j = 1$ single-particle state.

In perturbation theory to first order in V_0 the energy of this state is given by [see Eq. (9.32)]

$$E = 2\varepsilon_1 + \langle \text{GS} | V | \text{GS} \rangle + O(V_0^2) , \quad (16.144)$$

where the many-particle interaction operator V is given by Eq. (16.57). The matrix element $\langle \text{GS} | V | \text{GS} \rangle$ is given by

$$\begin{aligned} \langle \text{GS} | V | \text{GS} \rangle &= \frac{1}{2} \langle 1, 1 | V_{\text{TP}} | 1, 1 \rangle \langle \text{GS} | a_1^\dagger a_1^\dagger a_1 a_1 | \text{GS} \rangle \\ &= \frac{1}{2} \langle 1, 1 | V_{\text{TP}} | 1, 1 \rangle \langle \text{GS} | a_1^\dagger \left(a_1 a_1^\dagger - [a_1, a_1^\dagger] \right) a_1 | \text{GS} \rangle \\ &= \langle 1, 1 | V_{\text{TP}} | 1, 1 \rangle \langle \text{GS} | \frac{N_1(N_1 - 1)}{2} | \text{GS} \rangle \\ &= \langle 1, 1 | V_{\text{TP}} | 1, 1 \rangle , \end{aligned} \quad (16.145)$$

where the two-particle matrix element $\langle 1, 1 | V_{\text{TP}} | 1, 1 \rangle$ is given by

$$\begin{aligned} \langle 1, 1 | V_{\text{TP}} | 1, 1 \rangle &= \int_0^L dx_1 \int_0^L dx_2 \psi_1(x_1) \psi_1(x_2) V_{\text{TP}}(x_1, x_2) \psi_1(x_1) \psi_1(x_2) \\ &= -V_0 L \int_0^L dx_1 \psi_1^4(x_1) \\ &= -\frac{3}{2} V_0 , \end{aligned} \quad (16.146)$$

thus

$$E = \frac{\hbar^2 \pi^2}{mL^2} - \frac{3}{2} V_0 + O(V_0^2) . \quad (16.147)$$

6. The grandcanonical partition function [see Eq. (8.626)] is evaluated by summing over all many-particle states

$$\begin{aligned} Z_{\text{gc}} &= \text{Tr} \left(e^{-\beta \mathcal{H} + \beta \mu N} \right) \\ &= \sum_{n_1, n_2, \dots} \langle n_1, n_2, \dots, n_i, \dots | e^{-\beta \mathcal{H} + \beta \mu N} | n_1, n_2, \dots, n_i, \dots \rangle , \end{aligned} \quad (16.148)$$

where

$$\mathcal{H} = \sum_i \varepsilon_i a_i^\dagger a_i , \quad (16.149)$$

$$N = \sum_i a_i^\dagger a_i , \quad (16.150)$$

and $\beta = 1/(k_B T)$, thus one finds that

$$Z_{\text{gc}} = \prod_i \sum_{n_i} e^{-\beta n_i (\varepsilon_i - \mu)} . \quad (16.151)$$

and

$$\log Z_{\text{gc}} = \sum_i \log \left(\sum_{n_i} e^{-\beta n_i (\varepsilon_i - \mu)} \right) . \quad (16.152)$$

- a) In this case the summation over n_i includes only two terms $n_i = 0$ and $n_i = 1$, thus

$$\log Z_{\text{gc}} = \sum_i \log \left(1 + e^{-\beta(\varepsilon_i - \mu)} \right) . \quad (16.153)$$

The average energy is found using Eq. (8.627)

$$\begin{aligned} \langle \mathcal{H} \rangle &= - \left(\frac{\partial \log Z_{\text{gc}}}{\partial \beta} \right)_{\mu} + \frac{\mu}{\beta} \left(\frac{\partial \log Z_{\text{gc}}}{\partial \mu} \right)_{\beta} \\ &= \sum_i \frac{\varepsilon_i e^{-\beta(\varepsilon_i - \mu)}}{1 + e^{-\beta(\varepsilon_i - \mu)}} , \end{aligned} \quad (16.154)$$

whereas the average number of particles is found using Eq. (8.630)

$$\langle N \rangle = \lambda \frac{\partial \log Z_{\text{gc}}}{\partial \lambda} = \sum_i \frac{e^{-\beta(\varepsilon_i - \mu)}}{1 + e^{-\beta(\varepsilon_i - \mu)}} , \quad (16.155)$$

In terms of the Fermi-Dirac function $f_{\text{FD}}(\varepsilon)$, which is given by

$$f_{\text{FD}}(\varepsilon) = \frac{1}{\exp[\beta(\varepsilon - \mu)] + 1} , \quad (16.156)$$

these results can be rewritten as

$$\langle \mathcal{H} \rangle = \sum_i \varepsilon_i f_{\text{FD}}(\varepsilon_i) , \quad (16.157)$$

and

$$\langle N \rangle = \sum_i f_{\text{FD}}(\varepsilon_i) . \quad (16.158)$$

- b) In this case the summation over n_i includes all integers $n_i = 0, 1, 2, \dots$, thus

$$\log Z_{\text{gc}} = \sum_i \log \left(\frac{1}{1 - e^{-\beta(\varepsilon_i - \mu)}} \right) . \quad (16.159)$$

The average energy is found using Eq. (8.627)

$$\langle \mathcal{H} \rangle = \sum_i \varepsilon_i f_{\text{BE}}(\varepsilon_i) ,$$

whereas the average number of particles is found using Eq. (8.630)

$$\langle N \rangle = \sum_i f_{\text{BE}}(\varepsilon_i) , \quad (16.160)$$

where

$$f_{\text{BE}}(\varepsilon) = \frac{1}{\exp[\beta(\varepsilon - \mu)] - 1} \quad (16.161)$$

is the Bose-Einstein function .

7. The operators $a_{\mathbf{k}}$ and $a_{\mathbf{k}}^\dagger$ satisfy [see Eqs. (16.6), (16.7), (16.8) and (16.9)]

$$[a_{\mathbf{k}'}, a_{\mathbf{k}''}]_{\pm} = [a_{\mathbf{k}'}^\dagger, a_{\mathbf{k}''}^\dagger]_{\pm} = 0 , \quad (16.162)$$

$$[a_{\mathbf{k}'}, a_{\mathbf{k}''}^\dagger]_{\pm} = \delta_{\mathbf{k}', \mathbf{k}''} . \quad (16.163)$$

Similarly, The operators $b_{\mathbf{k}}$ and $b_{\mathbf{k}}^\dagger$ can be considered as annihilation and creation operators provided that they satisfy

$$[b_{\mathbf{k}'}, b_{\mathbf{k}''}]_{\pm} = [b_{\mathbf{k}'}^\dagger, b_{\mathbf{k}''}^\dagger]_{\pm} = 0 , \quad (16.164)$$

$$[b_{\mathbf{k}'}, b_{\mathbf{k}''}^\dagger]_{\pm} = \delta_{\mathbf{k}', \mathbf{k}''} . \quad (16.165)$$

Using the definition (16.112) together with Eqs. (16.6) and (16.8) these conditions become

$$u_{\mathbf{k}'} u_{\mathbf{k}''} [a_{-\mathbf{k}'}, a_{\mathbf{k}''}]_{\pm} + u_{\mathbf{k}'} v_{\mathbf{k}''} [a_{\mathbf{k}'}, a_{-\mathbf{k}''}]_{\pm} = 0 , \quad (16.166)$$

$$v_{\mathbf{k}'} u_{\mathbf{k}''} [a_{-\mathbf{k}'}, a_{\mathbf{k}''}^\dagger]_{\pm} + u_{\mathbf{k}'} v_{\mathbf{k}''} [a_{\mathbf{k}'}, a_{-\mathbf{k}''}]_{\pm} = 0 , \quad (16.167)$$

$$u_{\mathbf{k}'} u_{\mathbf{k}''} [a_{\mathbf{k}'}, a_{\mathbf{k}''}^\dagger]_{\pm} + v_{\mathbf{k}'} v_{\mathbf{k}''} [a_{-\mathbf{k}'}, a_{-\mathbf{k}''}]_{\pm} = \delta_{\mathbf{k}', \mathbf{k}''} . \quad (16.168)$$

Note that by inverting the transformation between the operators $a_{\mathbf{k}}$, $a_{-\mathbf{k}}$, $a_{\mathbf{k}}^\dagger$ and $a_{-\mathbf{k}}^\dagger$ and the operators $b_{\mathbf{k}}$, $b_{-\mathbf{k}}$, $b_{\mathbf{k}}^\dagger$ and $b_{-\mathbf{k}}^\dagger$, which can be expressed in matrix form as [see Eq. (16.112)]

$$\begin{pmatrix} b_{\mathbf{k}} \\ b_{-\mathbf{k}} \\ b_{\mathbf{k}}^\dagger \\ b_{-\mathbf{k}}^\dagger \end{pmatrix} = \begin{pmatrix} u_{\mathbf{k}} & 0 & 0 & v_{\mathbf{k}} \\ 0 & u_{-\mathbf{k}} & v_{-\mathbf{k}} & 0 \\ 0 & v_{\mathbf{k}} & u_{\mathbf{k}} & 0 \\ v_{-\mathbf{k}} & 0 & 0 & u_{-\mathbf{k}} \end{pmatrix} \begin{pmatrix} a_{\mathbf{k}} \\ a_{-\mathbf{k}} \\ a_{\mathbf{k}}^\dagger \\ a_{-\mathbf{k}}^\dagger \end{pmatrix} , \quad (16.169)$$

one finds that

$$\begin{pmatrix} a_{\mathbf{k}} \\ a_{-\mathbf{k}} \\ a_{\mathbf{k}}^\dagger \\ a_{-\mathbf{k}}^\dagger \end{pmatrix} = \frac{1}{u_{\mathbf{k}} u_{-\mathbf{k}} - v_{\mathbf{k}} v_{-\mathbf{k}}} \begin{pmatrix} u_{-\mathbf{k}} & 0 & 0 & -v_{\mathbf{k}} \\ 0 & u_{\mathbf{k}} & -v_{-\mathbf{k}} & 0 \\ 0 & -v_{\mathbf{k}} & u_{-\mathbf{k}} & 0 \\ -v_{-\mathbf{k}} & 0 & 0 & u_{\mathbf{k}} \end{pmatrix} \begin{pmatrix} b_{\mathbf{k}} \\ b_{-\mathbf{k}} \\ b_{\mathbf{k}}^\dagger \\ b_{-\mathbf{k}}^\dagger \end{pmatrix} .$$

$$(16.170)$$

This result together with Eq. (16.113) imply that the expectation value $\langle V_b | a_{\mathbf{k}}^\dagger a_{\mathbf{k}} | V_b \rangle$ is given by

$$\langle V_b | a_{\mathbf{k}}^\dagger a_{\mathbf{k}} | V_b \rangle = \left(\frac{v_{\mathbf{k}}}{u_{\mathbf{k}} u_{-\mathbf{k}} - v_{\mathbf{k}} v_{-\mathbf{k}}} \right)^2 \langle V_b | b_{-\mathbf{k}} b_{-\mathbf{k}}^\dagger | V_b \rangle , \quad (16.171)$$

thus for both Bosons and Fermions [see Eq. (16.165)]

$$\langle V_b | a_{\mathbf{k}}^\dagger a_{\mathbf{k}} | V_b \rangle = \left(\frac{v_{\mathbf{k}}}{u_{\mathbf{k}} u_{-\mathbf{k}} - v_{\mathbf{k}} v_{-\mathbf{k}}} \right)^2 . \quad (16.172)$$

- a) For the case of Fermions one finds using Eq. (16.9) that the conditions (16.166), (16.167) and (16.168) become (recall that $[A, B]_+ = [B, A]_+$)

$$(v_{\mathbf{k}'} u_{\mathbf{k}''} + u_{\mathbf{k}'} v_{\mathbf{k}''}) \delta_{\mathbf{k}', -\mathbf{k}''} = 0 , \quad (16.173)$$

$$(v_{\mathbf{k}'} u_{\mathbf{k}''} + u_{\mathbf{k}'} v_{\mathbf{k}''}) \delta_{\mathbf{k}', -\mathbf{k}''} = 0 , \quad (16.174)$$

$$(u_{\mathbf{k}'} u_{\mathbf{k}''} + v_{\mathbf{k}'} v_{\mathbf{k}''}) \delta_{\mathbf{k}', \mathbf{k}''} = \delta_{\mathbf{k}', \mathbf{k}''} , \quad (16.175)$$

thus

$$v_{\mathbf{k}} u_{-\mathbf{k}} + u_{\mathbf{k}} v_{-\mathbf{k}} = 0 , \quad (16.176)$$

$$u_{\mathbf{k}}^2 + v_{\mathbf{k}}^2 = 1 . \quad (16.177)$$

These conditions are guaranteed to be satisfied provided $u_{\mathbf{k}}$ and $v_{\mathbf{k}}$ are expressed using a single real parameter $\theta_{\mathbf{k}}$ as

$$u_{\mathbf{k}} = \cos \theta_{\mathbf{k}} , v_{\mathbf{k}} = \sin \theta_{\mathbf{k}} , \quad (16.178)$$

$$u_{-\mathbf{k}} = \cos \theta_{\mathbf{k}} , v_{-\mathbf{k}} = -\sin \theta_{\mathbf{k}} . \quad (16.179)$$

For this case Eq. (16.170) becomes

$$\begin{pmatrix} a_{\mathbf{k}} \\ a_{-\mathbf{k}} \\ a_{\mathbf{k}}^\dagger \\ a_{-\mathbf{k}}^\dagger \end{pmatrix} = \begin{pmatrix} \cos \theta_{\mathbf{k}} & 0 & 0 & -\sin \theta_{\mathbf{k}} \\ 0 & \cos \theta_{\mathbf{k}} & \sin \theta_{\mathbf{k}} & 0 \\ 0 & -\sin \theta_{\mathbf{k}} & \cos \theta_{\mathbf{k}} & 0 \\ \sin \theta_{\mathbf{k}} & 0 & 0 & \cos \theta_{\mathbf{k}} \end{pmatrix} \begin{pmatrix} b_{\mathbf{k}} \\ b_{-\mathbf{k}} \\ b_{\mathbf{k}}^\dagger \\ b_{-\mathbf{k}}^\dagger \end{pmatrix} , \quad (16.180)$$

and Eq. (16.172) becomes

$$\langle V_b | a_{\mathbf{k}}^\dagger a_{\mathbf{k}} | V_b \rangle = \sin^2 \theta_{\mathbf{k}} . \quad (16.181)$$

- b) For the case of Bosons one finds using Eq. (16.7) that the conditions (16.166), (16.167) and (16.168) become (recall that $[A, B]_- = -[B, A]_-$)

$$-v_{\mathbf{k}} u_{-\mathbf{k}} + u_{\mathbf{k}} v_{-\mathbf{k}} = 0 , \quad (16.182)$$

$$u_{\mathbf{k}}^2 - v_{\mathbf{k}}^2 = 1 . \quad (16.183)$$

These conditions are guaranteed to be satisfied provided that $u_{\mathbf{k}}$ and $v_{\mathbf{k}}$ are expressed using a single real parameter $\theta_{\mathbf{k}}$ as

$$u_{\mathbf{k}} = \cosh \theta_{\mathbf{k}} , v_{\mathbf{k}} = \sinh \theta_{\mathbf{k}} , \quad (16.184)$$

$$u_{-\mathbf{k}} = \cosh \theta_{\mathbf{k}} , v_{-\mathbf{k}} = \sinh \theta_{\mathbf{k}} . \quad (16.185)$$

For this case Eq. (16.172) thus becomes

$$\langle V_b | a_{\mathbf{k}}^\dagger a_{\mathbf{k}} | V_b \rangle = \sinh^2 \theta_{\mathbf{k}} . \quad (16.186)$$

8. Consider the unitary transformation [see for comparison Eq. (9.49)]

$$\bar{\mathcal{H}}_{\mathbf{k}'} = e^{L_{\mathbf{k}'}} \mathcal{H}_{\mathbf{k}'} e^{-L_{\mathbf{k}'}} , \quad (16.187)$$

where

$$\mathcal{H}_{\mathbf{k}'} = \epsilon_{\mathbf{k}'} \left[a_{\mathbf{k}'}^\dagger a_{\mathbf{k}'} + \lambda \left(a_{\mathbf{k}'} + a_{\mathbf{k}'}^\dagger \right) \right] , \quad (16.188)$$

and where

$$L_{\mathbf{k}'} = -\lambda \left(a_{\mathbf{k}'} - a_{\mathbf{k}'}^\dagger \right) . \quad (16.189)$$

With the help of Eq. (2.182), which is given by

$$e^L A e^{-L} = A + [L, A] + \frac{1}{2!} [L, [L, A]] + \frac{1}{3!} [L, [L, [L, A]]] + \dots , \quad (16.190)$$

and the identities

$$\left[a_{\mathbf{k}'} , a_{\mathbf{k}'}^\dagger a_{\mathbf{k}'} \right] = a_{\mathbf{k}'} , \quad (16.191)$$

$$\left[a_{\mathbf{k}'}^\dagger , a_{\mathbf{k}'}^\dagger a_{\mathbf{k}'} \right] = -a_{\mathbf{k}'}^\dagger , \quad (16.192)$$

$$\left[a_{\mathbf{k}'} - a_{\mathbf{k}'}^\dagger , a_{\mathbf{k}'} + a_{\mathbf{k}'}^\dagger \right] = 2 , \quad (16.193)$$

one finds that

$$\begin{aligned} \bar{\mathcal{H}}_{\mathbf{k}'} &= \mathcal{H}_{\mathbf{k}'} - \lambda \epsilon_{\mathbf{k}'} \left(a_{\mathbf{k}'} + a_{\mathbf{k}'}^\dagger \right) - 2\epsilon_{\mathbf{k}'} \lambda^2 + \epsilon_{\mathbf{k}'} \lambda^2 \\ &= \epsilon_{\mathbf{k}'} \left(a_{\mathbf{k}'}^\dagger a_{\mathbf{k}'} - \lambda^2 \right) . \end{aligned} \quad (16.194)$$

Thus, the unitary transformation

$$\bar{\mathcal{H}} = U^\dagger \mathcal{H} U , \quad (16.195)$$

where

$$U = \exp \left(- \sum_{\mathbf{k}'} L_{\mathbf{k}'} \right) , \quad (16.196)$$

which yields

$$\bar{\mathcal{H}} = \sum_{\mathbf{k}'} \epsilon_{\mathbf{k}'} \left(a_{\mathbf{k}'}^\dagger a_{\mathbf{k}'} - \lambda^2 \right) , \quad (16.197)$$

can be employed for diagonalization of \mathcal{H} . Let $|\bar{n}\rangle$ be a number state, which satisfy

$$a_{\mathbf{k}'}^\dagger a_{\mathbf{k}'} |\bar{n}\rangle = n_{\mathbf{k}'} |\bar{n}\rangle , \quad (16.198)$$

where $n_{\mathbf{k}'}$ is the number of particles in single-particle state $|\mathbf{k}'\rangle$. The following holds

$$\begin{aligned} \mathcal{H}U |\bar{n}\rangle &= UU^\dagger \mathcal{H}U |\bar{n}\rangle \\ &= U \bar{\mathcal{H}} |\bar{n}\rangle \\ &= \sum_{\mathbf{k}'} \epsilon_{\mathbf{k}'} (n_{\mathbf{k}'} - \lambda^2) U |\bar{n}\rangle , \end{aligned} \quad (16.199)$$

thus the eigenvectors of \mathcal{H} are the vectors $U |\bar{n}\rangle$ and the corresponding eigenenergies are given by

$$E_{\bar{n}} = \sum_{\mathbf{k}'} \epsilon_{\mathbf{k}'} (n_{\mathbf{k}'} - \lambda^2) . \quad (16.200)$$

9. By employing the Bogoliubov transformation [see Eqs. (16.170), (16.184) and (16.185)]

$$\begin{pmatrix} a_{\mathbf{k}'} \\ a_{-\mathbf{k}'} \\ a_{\mathbf{k}'}^\dagger \\ a_{-\mathbf{k}'}^\dagger \end{pmatrix} = \frac{1}{u_{\mathbf{k}'} u_{-\mathbf{k}'} - v_{\mathbf{k}'} v_{-\mathbf{k}'}} \begin{pmatrix} u_{-\mathbf{k}'} & 0 & 0 & -v_{\mathbf{k}'} \\ 0 & u_{\mathbf{k}'} & -v_{-\mathbf{k}'} & 0 \\ 0 & -v_{\mathbf{k}'} & u_{-\mathbf{k}'} & 0 \\ -v_{-\mathbf{k}'} & 0 & 0 & u_{\mathbf{k}'} \end{pmatrix} \begin{pmatrix} b_{\mathbf{k}'} \\ b_{-\mathbf{k}'} \\ b_{\mathbf{k}'}^\dagger \\ b_{-\mathbf{k}'}^\dagger \end{pmatrix} , \quad (16.201)$$

where

$$u_{\mathbf{k}'} = u_{-\mathbf{k}'} = \cosh \theta_{\mathbf{k}'} , \quad (16.202)$$

$$v_{\mathbf{k}'} = v_{-\mathbf{k}'} = \sinh \theta_{\mathbf{k}'} , \quad (16.203)$$

the identities

$$\sinh(2\theta_{\mathbf{k}'}) = 2 \sinh \theta_{\mathbf{k}'} \cosh \theta_{\mathbf{k}'} , \quad (16.204)$$

$$\cosh(2\theta_{\mathbf{k}'}) = \sinh^2 \theta_{\mathbf{k}'} + \cosh^2 \theta_{\mathbf{k}'} , \quad (16.205)$$

$$\cosh^2 \theta_{\mathbf{k}'} = \frac{\cosh(2\theta_{\mathbf{k}'}) + 1}{2} , \quad (16.206)$$

$$\sinh^2 \theta_{\mathbf{k}'} = \frac{\cosh(2\theta_{\mathbf{k}'}) - 1}{2} , \quad (16.207)$$

and the commutation relation $[b_{\mathbf{k}'}, b_{\mathbf{k}'}^\dagger] = 1$, one finds that

$$\begin{aligned}
 \mathcal{H} &= \sum_{\mathbf{k}'} ((\epsilon_{\mathbf{k}'} + \xi_{\mathbf{k}'}) \cosh(2\theta_{\mathbf{k}'}) - \xi_{\mathbf{k}'} \sinh(2\theta_{\mathbf{k}'})) b_{\mathbf{k}'}^\dagger b_{\mathbf{k}'} \\
 &+ \sum_{\mathbf{k}'} (\epsilon_{\mathbf{k}'} + \xi_{\mathbf{k}'}) \frac{\cosh(2\theta_{\mathbf{k}'}) - 1}{2} - \frac{\xi_{\mathbf{k}'} \sinh(2\theta_{\mathbf{k}'})}{2} \\
 &+ \sum_{\mathbf{k}'} \left(\frac{\xi_{\mathbf{k}'} \cosh(2\theta_{\mathbf{k}'}) - (\epsilon_{\mathbf{k}'} + \xi_{\mathbf{k}'}) \sinh(2\theta_{\mathbf{k}'})}{2} \right) (b_{\mathbf{k}'} b_{-\mathbf{k}'} + b_{\mathbf{k}'}^\dagger b_{-\mathbf{k}'}^\dagger) .
 \end{aligned} \tag{16.208}$$

To eliminate the mixed terms $b_{\mathbf{k}'} b_{-\mathbf{k}'}$ and $b_{\mathbf{k}'}^\dagger b_{-\mathbf{k}'}^\dagger$ the factors $\theta_{\mathbf{k}'}$ are chosen such that

$$\xi_{\mathbf{k}'} \cosh(2\theta_{\mathbf{k}'}) - (\epsilon_{\mathbf{k}'} + \xi_{\mathbf{k}'}) \sinh(2\theta_{\mathbf{k}'}) = 0 . \tag{16.209}$$

Using the identities

$$\cosh^2(2\theta_{\mathbf{k}'}) = \frac{1}{1 - \tanh^2(2\theta_{\mathbf{k}'})} , \tag{16.210}$$

$$\sinh^2(2\theta_{\mathbf{k}'}) = \frac{\tanh^2(2\theta_{\mathbf{k}'})}{1 - \tanh^2(2\theta_{\mathbf{k}'})} , \tag{16.211}$$

one finds that for that choice \mathcal{H} becomes diagonal

$$\mathcal{H} = \sum_{\mathbf{k}'} \left(\eta_{\mathbf{k}'} \left(b_{\mathbf{k}'}^\dagger b_{\mathbf{k}'} + \frac{1}{2} \right) - \frac{\epsilon_{\mathbf{k}'} + \xi_{\mathbf{k}'}}{2} \right) , \tag{16.212}$$

where (Bogoliubov dispersion relation)

$$\eta_{\mathbf{k}'} = \sqrt{\epsilon_{\mathbf{k}'}^2 + 2\epsilon_{\mathbf{k}'} \xi_{\mathbf{k}'}} , \tag{16.213}$$

and thus, the eigenenergies are given by

$$E_{\bar{n}} = \sum_{\mathbf{k}'} \left(\eta_{\mathbf{k}'} \left(n_{\mathbf{k}'} + \frac{1}{2} \right) - \frac{\epsilon_{\mathbf{k}'} + \xi_{\mathbf{k}'}}{2} \right) , \tag{16.214}$$

where the nonnegative integer $n_{\mathbf{k}'}$ is the number of so-called quasi particles in state \mathbf{k}' .

10. In terms of the Bose-Einstein function $f_{\text{BE}}(\varepsilon)$, which is given by Eq. (16.161), one finds that

$$N_0 = f_{\text{BE}}(0) = \frac{1}{\exp(-\beta\mu) - 1} , \tag{16.215}$$

and [see Eq. (14.74), and compare with Eq. (16.104)]

$$\begin{aligned}
N_e &= \sum_{\mathbf{k}} f_{\text{BE}} \left(\frac{\hbar^2 k^2}{2m} \right) \\
&= \frac{4\pi V}{(2\pi)^3} \int_0^\infty dk \frac{k^2}{\exp [\beta (\frac{\hbar^2 k^2}{2m} - \mu)] - 1} \\
&= \frac{m\sqrt{2m}V}{2\pi^2 \hbar^3} \int_0^\infty d\epsilon' \frac{\sqrt{\epsilon'}}{\exp [\beta (\epsilon' - \mu)] - 1} \\
&= \frac{2\beta^{\frac{3}{2}} V}{\sqrt{\pi} \lambda_{\text{T}}^3} \int_0^\infty d\epsilon' \frac{\sqrt{\epsilon'}}{\exp [\beta (\epsilon' - \mu)] - 1},
\end{aligned} \tag{16.216}$$

where $\beta^{-1} = k_{\text{B}}T$ is the thermal energy, μ is the chemical potential, and λ_{T} , which is given by

$$\lambda_{\text{T}} = \sqrt{\frac{\hbar^2 \beta}{2\pi m}}, \tag{16.217}$$

is the thermal wavelength, hence

$$n = \frac{N}{V} = \frac{1}{V} \frac{f}{1-f} + \frac{\eta(f)}{\lambda_{\text{T}}^3}, \tag{16.218}$$

where $f = e^{\beta\mu}$ is the fugacity [see Eq. (8.629)], and the function $\eta(f)$ is defined by

$$\eta(f) = \frac{2}{\sqrt{\pi}} \int_0^\infty dx \frac{f\sqrt{x}}{\exp x - f}. \tag{16.219}$$

With the help of the relations

$$\frac{f}{\exp x - f} = \sum_{n=1}^{\infty} \frac{f^n}{e^{nx}}, \tag{16.220}$$

and

$$\frac{2}{\sqrt{\pi}} \int_0^\infty dx \frac{\sqrt{x}}{e^{nx}} = \frac{1}{n^{\frac{3}{2}}}, \tag{16.221}$$

one finds that

$$\eta(f) = \sum_{n=1}^{\infty} \frac{f^n}{n^{\frac{3}{2}}}. \tag{16.222}$$

The function $\eta(f)$ converges in the range $0 \leq f \leq 1$, and the following holds

$$\eta(1) = \sum_{n=1}^{\infty} \frac{1}{n^{\frac{3}{2}}} = \zeta\left(\frac{3}{2}\right) \simeq 2.612, \quad (16.223)$$

where $\zeta(s)$, which is defined by

$$\zeta(s) = \sum_{n=1}^{\infty} \frac{1}{n^s}, \quad (16.224)$$

is the Riemann zeta function. The given density $n = N/V$ is related to μ (which is not given) by Eq. (16.218), which is rewritten as [see Eqs. (16.215) and (16.217), and recall that $N_0 = f/(1-f)$ and $n_0 = N_0/V$]

$$n = n_0 + n \left(\frac{T}{T_c}\right)^{3/2} \frac{\eta(f)}{\zeta\left(\frac{3}{2}\right)}, \quad (16.225)$$

where the so-called Bose–Einstein condensate critical temperature T_c is given by

$$T_c = \frac{n^{2/3} h^2}{2\pi m k_B \left(\zeta\left(\frac{3}{2}\right)\right)^{2/3}}. \quad (16.226)$$

For $T > T_c$ Eq. (16.225) implies that $n_0 = 0$. For the case $T < T_c$, the approximation $\eta(f) \simeq \zeta(3/2)$, which is valid provided that $1-f \ll 1$ (i.e. the temperature T is close to T_c), yields

$$\frac{n_0}{n} = 1 - \left(\frac{T}{T_c}\right)^{3/2}. \quad (16.227)$$

11. The result (16.118) is obtained by substituting the expression for the quantized field operator $\Psi(\mathbf{r}', t)$ given by Eq. (16.116) [with $\Psi'(\mathbf{r}', t)$ being disregarded] into Eq. (16.68), and employing Eq. (16.117).
12. The Bosonic commutation relations $[a_n, a_m^\dagger] = \delta_{n,m}$ and $[b_n, b_m^\dagger] = \delta_{n,m}$ can be expressed in a matrix form as

$$\left[\begin{pmatrix} a_1 \\ a_2 \end{pmatrix}, \begin{pmatrix} a_1^\dagger & a_2^\dagger \end{pmatrix} \right] = \left[\begin{pmatrix} b_1 \\ b_2 \end{pmatrix}, \begin{pmatrix} b_1^\dagger & b_2^\dagger \end{pmatrix} \right] = \begin{pmatrix} 1 & 0 \\ 0 & 1 \end{pmatrix}. \quad (16.228)$$

a) Using the relation [see Eq. (16.119)]

$$\left[\begin{pmatrix} b_1 \\ b_2 \end{pmatrix}, \begin{pmatrix} b_1^\dagger & b_2^\dagger \end{pmatrix} \right] = S \left[\begin{pmatrix} a_1 \\ a_2 \end{pmatrix}, \begin{pmatrix} a_1^\dagger & a_2^\dagger \end{pmatrix} \right] S^\dagger, \quad (16.229)$$

one finds that

$$SS^\dagger = \begin{pmatrix} t & r \\ r' & t' \end{pmatrix} \begin{pmatrix} t^* & r'^* \\ r^* & t'^* \end{pmatrix} = \begin{pmatrix} |r|^2 + |t|^2 & r'^* t + r t'^* \\ r' t^* + r^* t' & |r'|^2 + |t'|^2 \end{pmatrix} = \begin{pmatrix} 1 & 0 \\ 0 & 1 \end{pmatrix}, \quad (16.230)$$

hence Eqs. (16.121) and (16.122) hold.

b) Using the relation [see Eq. (16.119)]

$$S^\dagger \begin{pmatrix} b_1 \\ b_2 \end{pmatrix} = \begin{pmatrix} a_1 \\ a_2 \end{pmatrix}, \quad (16.231)$$

one finds that the input state $|\psi_{\text{in}}\rangle$, which is expressed as $|\psi_{\text{in}}\rangle = a_1^\dagger a_2^\dagger |0\rangle$, where $|0\rangle$ is the vacuum state, evolves into the state

$$\begin{aligned} |\psi_{\text{out}}\rangle &= (t^* b_1 + r'^* b_2)^\dagger (r^* b_1 + t'^* b_2)^\dagger |0\rangle \\ &= \sqrt{2} r t \frac{(b_1^\dagger)^2 |0\rangle}{\sqrt{2}} + \sqrt{2} r' t' \frac{(b_2^\dagger)^2 |0\rangle}{\sqrt{2}} \\ &\quad + (t t' + r r') b_1^\dagger b_2^\dagger |0\rangle, \end{aligned} \quad (16.232)$$

hence [recall that $r' t^* + r^* t' = 0$, hence $t t' + r r' = t t' (1 - |r/t|^2)$,

and note that the states $2^{-1/2} (b_1^\dagger)^2 |0\rangle$ and $2^{-1/2} (b_2^\dagger)^2 |0\rangle$ are normalized, as can be seen from Eq. (16.4)]

$$p_{11} = p_{22} = 2 |r t|^2, \quad (16.233)$$

$$p_{12} = |t t' + r r'|^2 = (|t|^2 - |r|^2)^2. \quad (16.234)$$

Note that $p_{11} + p_{22} + p_{12} = 1$. As can be seen from Eq. (16.234), for a symmetric beam splitter, i.e. for the case $|r| = |t|$, both photons will always exit the beam splitter in the same port (i.e. $p_{12} = 0$). This phenomenon is known as the Hong-Ou-Mandel bunching effect.

13. Consider the state $|\alpha(\mathbf{r}')\rangle$, which is defined by

$$|\alpha(\mathbf{r}')\rangle = D_{\alpha(\mathbf{r}')} |0\rangle, \quad (16.235)$$

where $\alpha(\mathbf{r}') \in \mathcal{C}$ and where the operator $D_{\alpha(\mathbf{r}'')}$ is given by [see for comparison Eq. (5.36)]

$$D_{\alpha(\mathbf{r}')} = e^{\int d\mathbf{r}' (\alpha(\mathbf{r}') \Psi^\dagger(\mathbf{r}') - \alpha^*(\mathbf{r}') \Psi(\mathbf{r}'))}. \quad (16.236)$$

For general operators A and B the following holds [see Eq. (2.184)]

$$e^{A+B} = e^A e^B e^{-\frac{1}{2}[A,B]} = e^B e^A e^{\frac{1}{2}[A,B]}, \quad (16.237)$$

provided that

$$[A, [A, B]] = [B, [A, B]] = 0. \quad (16.238)$$

Moreover, with the help of Eq. (16.40) one finds that

$$\begin{aligned}
 & \left[\int d\mathbf{r}' \alpha(\mathbf{r}') \Psi^\dagger(\mathbf{r}'), - \int d\mathbf{r}' \alpha^*(\mathbf{r}') \Psi(\mathbf{r}') \right] \\
 &= \int d\mathbf{r}' \int d\mathbf{r}'' \alpha(\mathbf{r}') \alpha^*(\mathbf{r}'') [\Psi(\mathbf{r}''), \Psi^\dagger(\mathbf{r}')] \\
 &= \int d\mathbf{r}' |\alpha(\mathbf{r}')|^2,
 \end{aligned} \tag{16.239}$$

thus [see for comparison Eq. (5.39)]

$$\begin{aligned}
 D_{\alpha(\mathbf{r}')} &= e^{\int d\mathbf{r}' \alpha(\mathbf{r}') \Psi^\dagger(\mathbf{r}')} e^{-\int d\mathbf{r}' \alpha^*(\mathbf{r}') \Psi(\mathbf{r}')} e^{-\frac{1}{2} \int d\mathbf{r}' |\alpha(\mathbf{r}')|^2} \\
 &= e^{-\int d\mathbf{r}' \alpha^*(\mathbf{r}') \Psi(\mathbf{r}')} e^{\int d\mathbf{r}' \alpha(\mathbf{r}') \Psi^\dagger(\mathbf{r}')} e^{\frac{1}{2} \int d\mathbf{r}' |\alpha(\mathbf{r}')|^2}.
 \end{aligned} \tag{16.240}$$

Using the last result (16.240) it is easy to show that $D_{\alpha(\mathbf{r}')}$ is unitary

$$D_{\alpha(\mathbf{r}')}^\dagger D_{\alpha(\mathbf{r}')} = D_{\alpha(\mathbf{r}')} D_{\alpha(\mathbf{r}')}^\dagger = 1, \tag{16.241}$$

and thus $|\alpha(\mathbf{r}')\rangle$ is normalized. With the help of Eq. (16.240) together with the relation $\Psi(\mathbf{r})|0\rangle = 0$ one finds that

$$|\alpha(\mathbf{r}')\rangle = e^{-\frac{1}{2} \int d\mathbf{r}' |\alpha(\mathbf{r}')|^2} e^{\int d\mathbf{r}' \alpha(\mathbf{r}') \Psi^\dagger(\mathbf{r}')} |0\rangle. \tag{16.242}$$

To show that $|\alpha(\mathbf{r}')\rangle$ is an eigenvector of the quantized field operator $\Psi(\mathbf{r})$ the commutation relation $[\exp(\int d\mathbf{r}' \alpha(\mathbf{r}') \Psi^\dagger(\mathbf{r}')), \Psi(\mathbf{r})]$ is evaluated below. For general operators A and B and for a smooth function $f(A)$ the following holds

$$[f(A), B] = \frac{df}{dA} [A, B], \tag{16.243}$$

provided that $[[A, B], A] = 0$ [see Eq. (2.183)]. Using this general result [with $f(A) = e^A$, $A = \int d\mathbf{r}' \alpha(\mathbf{r}') \Psi^\dagger(\mathbf{r}')$ and $B = \Psi(\mathbf{r})$] together with Eq. (16.40) yields

$$\begin{aligned}
 \left[e^{\int d\mathbf{r}' \alpha(\mathbf{r}') \Psi^\dagger(\mathbf{r}')} , \Psi(\mathbf{r}) \right] &= e^{\int d\mathbf{r}' \alpha(\mathbf{r}') \Psi^\dagger(\mathbf{r}')} \left[\int d\mathbf{r}' \alpha(\mathbf{r}') \Psi^\dagger(\mathbf{r}'), \Psi(\mathbf{r}) \right] \\
 &= -e^{\int d\mathbf{r}' \alpha(\mathbf{r}') \Psi^\dagger(\mathbf{r}')} \int d\mathbf{r}' \alpha(\mathbf{r}') \delta(\mathbf{r} - \mathbf{r}') \\
 &= -e^{\int d\mathbf{r}' \alpha(\mathbf{r}') \Psi^\dagger(\mathbf{r}')} \alpha(\mathbf{r}),
 \end{aligned} \tag{16.244}$$

The last result together with the relation $\Psi(\mathbf{r})|0\rangle = 0$ can be used to show that the state $|\alpha(\mathbf{r}')\rangle$ is an eigenvector of $\Psi(\mathbf{r})$ with eigenvalue $\alpha(\mathbf{r})$

$$\begin{aligned}
& \Psi(\mathbf{r}) |\alpha(\mathbf{r}')\rangle \\
&= \Psi(\mathbf{r}) e^{-\frac{1}{2} \int d\mathbf{r}' |\alpha(\mathbf{r}')|^2} e^{\int d\mathbf{r}' \alpha(\mathbf{r}') \Psi^\dagger(\mathbf{r}')} |0\rangle \\
&= e^{-\frac{1}{2} \int d\mathbf{r}' |\alpha(\mathbf{r}')|^2} \left(e^{\int d\mathbf{r}' \alpha(\mathbf{r}') \Psi^\dagger(\mathbf{r}')} \Psi(\mathbf{r}) + \left[\Psi(\mathbf{r}), e^{\int d\mathbf{r}' \alpha(\mathbf{r}') \Psi^\dagger(\mathbf{r}')} \right] \right) |0\rangle \\
&= \alpha(\mathbf{r}) e^{-\frac{1}{2} \int d\mathbf{r}' |\alpha(\mathbf{r}')|^2} e^{\int d\mathbf{r}' \alpha(\mathbf{r}') \Psi^\dagger(\mathbf{r}')} |0\rangle,
\end{aligned} \tag{16.245}$$

that is

$$\Psi(\mathbf{r}) |\alpha(\mathbf{r}')\rangle = \alpha(\mathbf{r}) |\alpha(\mathbf{r}')\rangle. \tag{16.246}$$

The expectation value with respect to the number operator N [see Eqs. (16.43) and (16.44)] is given by

$$\begin{aligned}
\langle \alpha(\mathbf{r}') | N | \alpha(\mathbf{r}') \rangle &= \int d^3\mathbf{r}' \langle \alpha(\mathbf{r}') | \Psi^\dagger(\mathbf{r}') \Psi(\mathbf{r}') | \alpha(\mathbf{r}') \rangle \\
&= \int d^3\mathbf{r}' |\alpha(\mathbf{r}')|^2,
\end{aligned}$$

whereas the expectation value with respect to the Hamiltonian \mathcal{H} [see Eq. (16.67)] is given by

$$\begin{aligned}
\langle \alpha(\mathbf{r}') | \mathcal{H} | \alpha(\mathbf{r}') \rangle &= \frac{\hbar^2}{2m} \int d^3\mathbf{r}' \nabla \alpha^*(\mathbf{r}') \cdot \nabla \alpha(\mathbf{r}') \\
&\quad + \int d^3\mathbf{r}' U_{\text{SP}}(\mathbf{r}') |\alpha(\mathbf{r}')|^2 \\
&\quad + \frac{1}{2} \int d^3\mathbf{r}' \int d^3\mathbf{r}'' V_{\text{TP}}(\mathbf{r}', \mathbf{r}'') |\alpha(\mathbf{r}'')|^2 |\alpha(\mathbf{r}')|^2.
\end{aligned} \tag{16.247}$$

14. First consider the unperturbed problem where the Coulomb interaction between the electrons is disregarded. The single-electron Hamiltonian is obtained by substituting the factor e^2 in the Hamiltonian of a hydrogen atom by Ze^2 , where for helium $Z = 2$. The single electron energy eigenstates $|n, l, m, \sigma\rangle$ are chosen to be also eigenvectors of the single electron angular momentum operators L_z and \mathbf{L}^2 [see Eqs. (7.42), (7.43) and (7.44)]. While n , l and m are orbital quantum numbers, σ labels the spin state. The single electron eigenenergies are given by [see Eq. (7.84)]

$$E_n = -\frac{Z^2 E_{\text{I}}}{n^2}, \tag{16.248}$$

where [see Eq. (7.66)]

$$E_{\text{I}} = \frac{m_e e^4}{2\hbar^2}, \tag{16.249}$$

and where m_e is the electron's mass. The position wavefunction $\psi_{n,l,m}(\mathbf{r})$ of a single-electron energy eigenstates having orbital quantum numbers n , l and m is given by [see Eq. (7.95)]

$$\psi_{nlm}(r, \theta, \phi) = R_{nl}^{(Z)}(r) Y_l^m(\theta, \phi) , \quad (16.250)$$

where the radial wavefunction $R_{nl}^{(Z)}(r)$ is obtained by substituting e^2 by Ze^2 in the radial wave function $R_{nl}(r)$ of hydrogen [see Eqs. (7.141), (7.142) and (7.143)]. The ground state $|\mathcal{Y}\rangle$ (when the Coulomb interaction between the electrons is disregarded) is given by [see Eq. (16.21)]

$$|\mathcal{Y}\rangle = a_{n=1,l=0,m=0,\sigma=-}^\dagger a_{n=1,l=0,m=0,\sigma=+}^\dagger |0\rangle , \quad (16.251)$$

where $a_{n,l,m,\sigma}^\dagger$ are creation operators and where $|0\rangle$ represents the state where all occupation numbers are zero. The energy of the unperturbed ground state is $-2 \times 2^2 E_1 = -8E_1$ [see Eq. (16.248)]. The Coulomb interaction between the electrons is described by the two-particle operator [see Eq. (16.107)]

$$V_{\text{TP}}(\mathbf{r}_1, \mathbf{r}_2) = \frac{e^2}{|\mathbf{r}_1 - \mathbf{r}_2|} . \quad (16.252)$$

In the many-particle case the two-electron interaction is represented by the operator V , which is given by Eq. (16.57). To first order in perturbation theory the energy of the ground state [see Eq. (9.32)] is given by $-8E_1 + \langle \mathcal{Y} | V | \mathcal{Y} \rangle$, where [see Eq. (7.141)]

$$\begin{aligned} \langle \mathcal{Y} | V | \mathcal{Y} \rangle &= \int d\mathbf{r}_1 \int d\mathbf{r}_2 |\psi_{1,0,0}(\mathbf{r}_1) \psi_{1,0,0}(\mathbf{r}_2)|^2 \frac{e^2}{|\mathbf{r}_1 - \mathbf{r}_2|} \\ &= \int d\mathbf{r}_1 \int d\mathbf{r}_2 \left| \frac{R_{10}^{(Z)}(r_1)}{\sqrt{4\pi}} \frac{R_{10}^{(Z)}(r_2)}{\sqrt{4\pi}} \right|^2 \frac{e^2}{|\mathbf{r}_1 - \mathbf{r}_2|} \\ &= \frac{e^2 \left(\frac{2}{a_0}\right)^6}{\pi^2} \int d\mathbf{r}_1 \int d\mathbf{r}_2 \frac{e^{-\frac{4(r_1+r_2)}{a_0}}}{|\mathbf{r}_1 - \mathbf{r}_2|} \\ &= \alpha E_1 , \end{aligned} \quad (16.253)$$

the dimensionless factor α is given by

$$\alpha = \frac{2^7}{\pi^2} \frac{1}{a_0^5} \int d\mathbf{r}_1 \int d\mathbf{r}_2 \frac{e^{-\frac{4(r_1+r_2)}{a_0}}}{|\mathbf{r}_1 - \mathbf{r}_2|} , \quad (16.254)$$

and where

$$a_0 = \frac{\hbar^2}{m_e e^2} \quad (16.255)$$

is the Bohr's radius [see Eq. (7.64)]. The integration over \mathbf{r}_2 is performed in spherical coordinates, where the z axis is chosen in the direction of the vector \mathbf{r}_1

$$\begin{aligned}
 \alpha &= \frac{2^7}{\pi^2} \frac{1}{a_0^5} \int d\mathbf{r}_1 e^{-\frac{4r_1}{a_0}} \int_0^\infty dr_2 r_2^2 e^{-\frac{4r_2}{a_0}} \underbrace{\int_{-1}^1 \frac{d(\cos \theta_2)}{\sqrt{r_1^2 + r_2^2 - 2r_1 r_2 \cos \theta_2}}}_{\frac{r_1+r_2-|r_1-r_2|}{r_1 r_2}} \underbrace{\int_0^{2\pi} d\phi_2}_{2\pi} \\
 &= 4\pi \frac{2^7}{\pi^2} \frac{1}{a_0^5} 4\pi \int_0^\infty dr_1 r_1^2 e^{-\frac{4r_1}{a_0}} \left(\frac{1}{r_1} \int_0^{r_1} dr_2 r_2^2 e^{-\frac{4r_2}{a_0}} + \int_{r_1}^\infty dr_2 r_2 e^{-\frac{4r_2}{a_0}} \right) \\
 &= \frac{5}{2},
 \end{aligned} \tag{16.256}$$

thus the ground state energy is $-8E_I + \langle \mathcal{Y} | V | \mathcal{Y} \rangle = -(11/2) E_I$. Note that the fact the energy correction $\langle \mathcal{Y} | V | \mathcal{Y} \rangle$ is comparable with the unperturbed value of $-8E_I$ suggests that the accuracy of the first order perturbation approximation is relatively poor.

15. With the help of the commutation relations (16.40), (16.41) and (16.42) one finds that

$$\begin{aligned}
 \langle \gamma | \gamma \rangle &= \int d\mathbf{r}' \int d\mathbf{r}'' \int d\mathbf{r}''' \int d\mathbf{r}'''' F(\mathbf{r}', \mathbf{r}'') F^*(\mathbf{r}''', \mathbf{r}'''') \\
 &\quad \times \langle 0 | \Psi(\mathbf{r}'''') \Psi(\mathbf{r}''') \Psi^\dagger(\mathbf{r}') \Psi^\dagger(\mathbf{r}'') | 0 \rangle \\
 &= \int d\mathbf{r}' \int d\mathbf{r}'' \int d\mathbf{r}'''' F(\mathbf{r}', \mathbf{r}'') F^*(\mathbf{r}', \mathbf{r}''') \langle 0 | \Psi(\mathbf{r}'''') \Psi^\dagger(\mathbf{r}'') | 0 \rangle \\
 &\quad + \int d\mathbf{r}' \int d\mathbf{r}'' \int d\mathbf{r}''' \int d\mathbf{r}'''' F(\mathbf{r}', \mathbf{r}'') F^*(\mathbf{r}''', \mathbf{r}'''') \langle 0 | \Psi(\mathbf{r}'''') \Psi^\dagger(\mathbf{r}') \Psi(\mathbf{r}''') \Psi^\dagger(\mathbf{r}'') | 0 \rangle \\
 &= \int d\mathbf{r}' \int d\mathbf{r}'' \left(|F(\mathbf{r}', \mathbf{r}'')|^2 + F(\mathbf{r}', \mathbf{r}'') F^*(\mathbf{r}'', \mathbf{r}') \right) .
 \end{aligned} \tag{16.257}$$

- a) The condition is

$$1 = \int d\mathbf{r}' \int d\mathbf{r}'' \left(|F(\mathbf{r}', \mathbf{r}'')|^2 + F(\mathbf{r}', \mathbf{r}'') F^*(\mathbf{r}'', \mathbf{r}') \right) . \tag{16.258}$$

- b) The normalization condition for this case reads

$$\begin{aligned}
 1 &= |A|^2 \int d\mathbf{r}' \int d\mathbf{r}'' \left(|f_1(\mathbf{r}') f_2(\mathbf{r}'')|^2 + f_1(\mathbf{r}') f_2(\mathbf{r}'') f_1^*(\mathbf{r}'') f_2^*(\mathbf{r}') \right) \\
 &= |A|^2 \left(1 + |\gamma_{12}|^2 \right) ,
 \end{aligned} \tag{16.259}$$

where

$$\gamma_{12} = \int d\mathbf{r}' f_1(\mathbf{r}') f_2^*(\mathbf{r}') . \quad (16.260)$$

The following holds [see Eqs. (16.40), (16.41) and (16.42)]

$$\begin{aligned} g(\mathbf{r}'''''') &= \frac{1}{1 + |\gamma_{12}|^2} \int d\mathbf{r}' \int d\mathbf{r}'' \int d\mathbf{r}''' \int d\mathbf{r}'''' f_1(\mathbf{r}') f_2(\mathbf{r}'') f_1^*(\mathbf{r}''') f_2^*(\mathbf{r}''''') \\ &\quad \times \langle 0 | \bar{\Psi}(\mathbf{r}'''''') \bar{\Psi}(\mathbf{r}''''') \bar{\Psi}^\dagger(\mathbf{r}'''''') \bar{\Psi}(\mathbf{r}'''''') \bar{\Psi}^\dagger(\mathbf{r}') \bar{\Psi}^\dagger(\mathbf{r}'') | 0 \rangle \\ &= \frac{|f_1(\mathbf{r}'''''')|^2 + |f_2(\mathbf{r}'''''')|^2 + \gamma_{12} f_1^*(\mathbf{r}'''''') f_2(\mathbf{r}'''''') + \gamma_{12}^* f_1(\mathbf{r}'''''') f_2^*(\mathbf{r}'''''')}{1 + |\gamma_{12}|^2} . \end{aligned} \quad (16.261)$$

c) The number of particles is given by

$$N_\gamma = \int d\mathbf{r}' g(\mathbf{r}') = 2 . \quad (16.262)$$

16. The correlation function $C_\sigma(\mathbf{r}' - \mathbf{r}'')$ is given by

$$C_\sigma(\mathbf{r}' - \mathbf{r}'') = \frac{1}{\mathcal{V}} \sum_{\mathbf{k}', \mathbf{k}''} e^{i(\mathbf{k}'' \cdot \mathbf{r}'' - \mathbf{k}' \cdot \mathbf{r}')} \langle \varphi_0 | a_{\mathbf{k}', \sigma}^\dagger a_{\mathbf{k}'', \sigma} | \varphi_0 \rangle , \quad (16.263)$$

where $|\varphi_0\rangle$ is the ground state of the free electron gas [see Eq. (16.99)], thus

$$C_\sigma(\mathbf{r}' - \mathbf{r}'') = \frac{1}{\mathcal{V}} \sum_{|\mathbf{k}'| \leq k_F} e^{i\mathbf{k}' \cdot (\mathbf{r}'' - \mathbf{r}')} . \quad (16.264)$$

For $N \gg 1$ the summation can be approximately substituted by integration over the Fermi sphere having radius k_F [see Eq. (16.101)]. In spherical coordinates in which the z axis is taken to be in the direction of the vector $\mathbf{r}'' - \mathbf{r}'$ one has

$$C_\sigma(\mathbf{r}' - \mathbf{r}'') = \frac{\mathcal{V}}{8\pi^3} \frac{2\pi}{\mathcal{V}} \int_0^{k_F} dk' k'^2 \int_{-1}^1 d(\cos\theta) e^{ik' \cos\theta |\mathbf{r}'' - \mathbf{r}'|} , \quad (16.265)$$

thus

$$C_\sigma(\mathbf{r}' - \mathbf{r}'') = \frac{1}{2\pi^2} \frac{\sin(k_F |\mathbf{r}'' - \mathbf{r}'|) - k_F |\mathbf{r}'' - \mathbf{r}'| \cos(k_F |\mathbf{r}'' - \mathbf{r}'|)}{|\mathbf{r}'' - \mathbf{r}'|^3} . \quad (16.266)$$

With the help of Eq. (16.101) the result can be expressed as

$$C_\sigma(\mathbf{r}' - \mathbf{r}'') = \frac{3N}{2\mathcal{V}} \frac{\sin(k_F |\mathbf{r}'' - \mathbf{r}'|) - k_F |\mathbf{r}'' - \mathbf{r}'| \cos(k_F |\mathbf{r}'' - \mathbf{r}'|)}{(k_F |\mathbf{r}'' - \mathbf{r}'|)^3} . \quad (16.267)$$

17. First consider the unperturbed case, where the electron-electron Coulomb interaction is disregarded. The ground state

$$|\varphi_0\rangle = \prod_{|\mathbf{k}'| \leq k_F, \sigma'} a_{\mathbf{k}', \sigma'}^\dagger |0\rangle \quad (16.268)$$

is given by Eq. (16.99), and its energy $E_0 = (3N/5)(\hbar^2 k_F^2/2m)$ by Eq. (16.106), where k_F is the Fermi wave vector. To first order in perturbation theory the energy of the ground state becomes $E_{\text{GS}}^{(1)} = E_0 + \Delta E$, where the energy shift ΔE due to electron-electron Coulomb interaction is given by [see Eqs. (9.32), (16.66), (16.94) and (16.107)]

$$\Delta E = \frac{1}{2} \sum_{\sigma', \sigma''} \int d^3 \mathbf{r}' \int d^3 \mathbf{r}'' V_{\text{TP}}(\mathbf{r}', \mathbf{r}'') \langle \varphi_0 | \Psi_{\sigma'}^\dagger(\mathbf{r}') \Psi_{\sigma''}^\dagger(\mathbf{r}'') \Psi_{\sigma''}(\mathbf{r}'') \Psi_{\sigma'}(\mathbf{r}') | \varphi_0 \rangle, \quad (16.269)$$

where

$$V_{\text{TP}}(\mathbf{r}', \mathbf{r}'') = \frac{e^2}{|\mathbf{r}' - \mathbf{r}''|}. \quad (16.270)$$

With the help of the expansion (16.97) and the commutation relations (16.92) and (16.93) one finds that

$$\begin{aligned} & \langle \varphi_0 | \Psi_{\sigma'}^\dagger(\mathbf{r}') \Psi_{\sigma''}^\dagger(\mathbf{r}'') \Psi_{\sigma''}(\mathbf{r}'') \Psi_{\sigma'}(\mathbf{r}') | \varphi_0 \rangle \\ &= \frac{1}{\mathcal{V}^2} \sum_{\mathbf{k}', \mathbf{k}'', \mathbf{k}''', \mathbf{k}''''} e^{i(\mathbf{k}'' - \mathbf{k}''') \cdot \mathbf{r}''} e^{i(\mathbf{k}' - \mathbf{k}'''') \cdot \mathbf{r}'} \langle \varphi_0 | a_{\mathbf{k}'''' , \sigma'}^\dagger a_{\mathbf{k}'''' , \sigma''}^\dagger a_{\mathbf{k}' , \sigma''} a_{\mathbf{k}' , \sigma'} | \varphi_0 \rangle \\ &= -\frac{1}{\mathcal{V}^2} \delta_{\sigma', \sigma''} \sum_{\mathbf{k}', \mathbf{k}'', \mathbf{k}''''} e^{i(\mathbf{k}'' - \mathbf{k}') \cdot \mathbf{r}''} e^{i(\mathbf{k}' - \mathbf{k}'''') \cdot \mathbf{r}'} \langle \varphi_0 | a_{\mathbf{k}'''' , \sigma'}^\dagger a_{\mathbf{k}' , \sigma'} | \varphi_0 \rangle \\ & \quad + \frac{1}{\mathcal{V}^2} \sum_{\mathbf{k}', \mathbf{k}'', \mathbf{k}''', \mathbf{k}''''} e^{i(\mathbf{k}'' - \mathbf{k}''') \cdot \mathbf{r}''} e^{i(\mathbf{k}' - \mathbf{k}'''') \cdot \mathbf{r}'} \langle \varphi_0 | a_{\mathbf{k}'''' , \sigma'}^\dagger a_{\mathbf{k}' , \sigma'} a_{\mathbf{k}'''' , \sigma''}^\dagger a_{\mathbf{k}' , \sigma''} | \varphi_0 \rangle. \end{aligned} \quad (16.271)$$

The only nonvanishing terms in the second line are those for which either $\mathbf{k}' = \mathbf{k}''''$ and $\mathbf{k}'' = \mathbf{k}'''$ or $\mathbf{k}' = \mathbf{k}'''$ and $\mathbf{k}'' = \mathbf{k}''''$. For the second case the two possibilities $\sigma' = \sigma''$ and $\sigma' \neq \sigma''$ are separately considered

$$\begin{aligned}
 & \langle \varphi_0 | \Psi_{\sigma'}^\dagger(\mathbf{r}') \Psi_{\sigma''}^\dagger(\mathbf{r}'') \Psi_{\sigma''}(\mathbf{r}'') \Psi_{\sigma'}(\mathbf{r}') | \varphi_0 \rangle \\
 = & -\frac{1}{\mathcal{V}^2} \delta_{\sigma', \sigma''} \sum_{\mathbf{k}'} e^{i\mathbf{k}' \cdot (\mathbf{r}' - \mathbf{r}'')} \sum_{|\mathbf{k}''| \leq k_F} e^{-i\mathbf{k}'' \cdot (\mathbf{r}' - \mathbf{r}'')} \\
 & + \frac{1}{\mathcal{V}^2} \sum_{\mathbf{k}', \mathbf{k}''} \langle \varphi_0 | N_{\mathbf{k}', \sigma'} N_{\mathbf{k}'', \sigma''} | \varphi_0 \rangle \\
 & + \frac{1}{\mathcal{V}^2} \delta_{\sigma', \sigma''} \sum_{\mathbf{k}', \mathbf{k}''} e^{i(\mathbf{k}' - \mathbf{k}'') \cdot (\mathbf{r}' - \mathbf{r}'')} \langle \varphi_0 | a_{\mathbf{k}'', \sigma'}^\dagger a_{\mathbf{k}', \sigma'} a_{\mathbf{k}', \sigma'}^\dagger a_{\mathbf{k}'', \sigma'} | \varphi_0 \rangle \\
 & + \frac{1}{\mathcal{V}^2} (1 - \delta_{\sigma', \sigma''}) \sum_{\mathbf{k}', \mathbf{k}''} e^{i(\mathbf{k}' - \mathbf{k}'') \cdot (\mathbf{r}' - \mathbf{r}'')} \langle \varphi_0 | a_{\mathbf{k}'', \sigma'}^\dagger a_{\mathbf{k}', \sigma'} a_{\mathbf{k}', \sigma''}^\dagger a_{\mathbf{k}'', \sigma''} | \varphi_0 \rangle ,
 \end{aligned} \tag{16.272}$$

thus

$$\begin{aligned}
 & \langle \varphi_0 | \Psi_{\sigma'}^\dagger(\mathbf{r}') \Psi_{\sigma''}^\dagger(\mathbf{r}'') \Psi_{\sigma''}(\mathbf{r}'') \Psi_{\sigma'}(\mathbf{r}') | \varphi_0 \rangle \\
 = & -\frac{1}{\mathcal{V}^2} \delta_{\sigma', \sigma''} \sum_{\mathbf{k}'} e^{i\mathbf{k}' \cdot (\mathbf{r}' - \mathbf{r}'')} \sum_{|\mathbf{k}''| \leq k_F} e^{-i\mathbf{k}'' \cdot (\mathbf{r}' - \mathbf{r}'')} \\
 & + \frac{1}{\mathcal{V}^2} \sum_{|\mathbf{k}'|, |\mathbf{k}''| \leq k_F} 1 \\
 & + \frac{1}{\mathcal{V}^2} \delta_{\sigma', \sigma''} \sum_{|\mathbf{k}'| \leq k_F} 1 \\
 & + \frac{1}{\mathcal{V}^2} \delta_{\sigma', \sigma''} \sum_{\mathbf{k}'} e^{i\mathbf{k}' \cdot (\mathbf{r}' - \mathbf{r}'')} \sum_{|\mathbf{k}''| \leq k_F} e^{-i\mathbf{k}'' \cdot (\mathbf{r}' - \mathbf{r}'')} \\
 & - \frac{1}{\mathcal{V}^2} \delta_{\sigma', \sigma''} \left| \sum_{|\mathbf{k}'| \leq k_F} e^{i\mathbf{k}' \cdot (\mathbf{r}' - \mathbf{r}'')} \right|^2 \\
 & + \frac{1}{\mathcal{V}^2} (1 - \delta_{\sigma', \sigma''}) \sum_{|\mathbf{k}'| \leq k_F} 1 .
 \end{aligned} \tag{16.273}$$

For $N \gg 1$ the single summation terms are negligibly small

$$\begin{aligned}
 & \langle \varphi_0 | \Psi_{\sigma'}^\dagger(\mathbf{r}') \Psi_{\sigma''}^\dagger(\mathbf{r}'') \Psi_{\sigma''}(\mathbf{r}'') \Psi_{\sigma'}(\mathbf{r}') | \varphi_0 \rangle \\
 = & \frac{1}{\mathcal{V}^2} \sum_{|\mathbf{k}''|, |\mathbf{k}'| \leq k_F} 1 - \frac{1}{\mathcal{V}^2} \delta_{\sigma', \sigma''} \left| \sum_{|\mathbf{k}'| \leq k_F} e^{i\mathbf{k}' \cdot (\mathbf{r}' - \mathbf{r}'')} \right|^2 ,
 \end{aligned} \tag{16.274}$$

or [see Eqs. (16.264) and (16.267)]

$$\begin{aligned}
& \langle \varphi_0 | \Psi_{\sigma'}^\dagger(\mathbf{r}') \Psi_{\sigma''}^\dagger(\mathbf{r}'') \Psi_{\sigma''}(\mathbf{r}'') \Psi_{\sigma'}(\mathbf{r}') | \varphi_0 \rangle \\
&= \left(\frac{N}{2\mathcal{V}} \right)^2 - \delta_{\sigma', \sigma''} |C(\mathbf{r}' - \mathbf{r}'')|^2,
\end{aligned} \tag{16.275}$$

where

$$C(\mathbf{r}' - \mathbf{r}'') = \frac{3N}{2\mathcal{V}} \frac{\sin(k_F |\mathbf{r}'' - \mathbf{r}'|) - k_F |\mathbf{r}'' - \mathbf{r}'| \cos(k_F |\mathbf{r}'' - \mathbf{r}'|)}{(k_F |\mathbf{r}'' - \mathbf{r}'|)^3}. \tag{16.276}$$

With the help of the above result one obtains

$$\begin{aligned}
\Delta E &= \frac{1}{2} \left(\frac{N}{\mathcal{V}} \right)^2 \int d^3\mathbf{r}' \int d^3\mathbf{r}'' V_{\text{TP}}(\mathbf{r}', \mathbf{r}'') \\
&\quad - \int d^3\mathbf{r}' \int d^3\mathbf{r}'' V_{\text{TP}}(\mathbf{r}', \mathbf{r}'') |C(\mathbf{r}' - \mathbf{r}'')|^2.
\end{aligned} \tag{16.277}$$

The first term of (16.277) represents the electrostatic energy due to electron-electron interaction. However, as is argued below, in the presence of positive charge density $+eN/\mathcal{V}$ this term should be disregarded. This can be seen by noticing that the self electrostatic energy of the positive background is identical to the first term of (16.277), whereas the electrostatic energy due to interaction between the electrons and the positive background is $-(N/\mathcal{V})^2 \int d^3\mathbf{r}' \int d^3\mathbf{r}'' V_{\text{TP}}(\mathbf{r}', \mathbf{r}'')$, thus these two contributions exactly cancel the first term of (16.277). The second term, which is commonly called the exchange energy, can be evaluated using Eq. (16.267). Thus the energy of the ground state $E_{\text{GS}}^{(1)}$ (to first order in perturbation theory) is given by

$$\begin{aligned}
E_{\text{GS}}^{(1)} &= \frac{3N}{5} \frac{\hbar^2 k_F^2}{2m} \\
&\quad - \mathcal{V} \int d^3\mathbf{r}' \frac{e^2}{|\mathbf{r}'|} \left(\frac{3N}{2\mathcal{V}} \right)^2 \frac{(\sin(k_F |\mathbf{r}'|) - k_F |\mathbf{r}'| \cos(k_F |\mathbf{r}'|))^2}{(k_F |\mathbf{r}'|)^6} \\
&= \frac{3N}{5} \frac{\hbar^2 k_F^2}{2m} - \frac{9\pi\mathcal{V}e^2 \left(\frac{N}{\mathcal{V}}\right)^2}{k_F^2} \underbrace{\int_0^\infty dx \frac{(\sin x - x \cos x)^2}{x^5}}_{1/4},
\end{aligned} \tag{16.278}$$

or [see Eq. (16.101)]

$$E_{\text{GS}}^{(1)} = N \left(\frac{3}{5} \frac{\hbar^2 k_F^2}{2m} - \frac{3k_F e^2}{4\pi} \right). \tag{16.279}$$

18. The entropy σ can be expressed in terms of the grandcanonical partition function Z_{gc} using Eq. (8.621), which reads

$$\sigma = \log Z_{\text{gc}} + \beta \langle \mathcal{H} \rangle + \eta \langle N \rangle , \quad (16.280)$$

where $\beta^{-1} = k_{\text{B}}T$ is the thermal energy, k_{B} is the Boltzmann's constant, T is the temperature, $\eta = -\beta\mu$, and μ is chemical potential. For non-interacting Fermions having single particle energies ε_i , the partition function Z_{gc} is given by $\log Z_{\text{gc}} = \sum_i \log(1 + e^{-\beta(\varepsilon_i - \mu)})$ [see Eq. (16.153)], the energy expectation value $\langle \mathcal{H} \rangle$ is given by [see Eq. (8.627)]

$$\langle \mathcal{H} \rangle = - \left(\frac{\partial \log Z_{\text{gc}}}{\partial \beta} \right)_{\mu} + \frac{\mu}{\beta} \left(\frac{\partial \log Z_{\text{gc}}}{\partial \mu} \right)_{\beta} = \sum_i \varepsilon_i n_i , \quad (16.281)$$

the number expectation value $\langle N \rangle$ is given by [see Eq. (8.630), $\lambda = e^{\beta\mu}$ is the fugacity]

$$\langle N \rangle = \lambda \frac{\partial \log Z_{\text{gc}}}{\partial \lambda} = \sum_i n_i , \quad (16.282)$$

where

$$n_i = f_{\text{FD}}(\varepsilon_i) , \quad (16.283)$$

and where $f_{\text{FD}}(\varepsilon)$, which is given by [see Eq. (16.156)]

$$f_{\text{FD}}(\varepsilon) = \frac{1}{\exp[\beta(\varepsilon - \mu)] + 1} , \quad (16.284)$$

is the Fermi-Dirac function. Using the relations

$$1 - f_{\text{FD}}(\varepsilon) = \frac{1}{\exp[-\beta(\varepsilon - \mu)] + 1} , \quad (16.285)$$

$$\beta(\varepsilon - \mu) = \log \frac{1 - f_{\text{FD}}(\varepsilon)}{f_{\text{FD}}(\varepsilon)} , \quad (16.286)$$

one finds that

$$\sigma = - \sum_i [n_i \log n_i + (1 - n_i) \log(1 - n_i)] . \quad (16.287)$$

For the case of a free electron gas (the factor of 2 is due to spin)

$$\sigma = -2 \sum_{\mathbf{k}'} [n_{\mathbf{k}'} \log n_{\mathbf{k}'} + (1 - n_{\mathbf{k}'}) \log(1 - n_{\mathbf{k}'})] , \quad (16.288)$$

where $n_{\mathbf{k}'} = f_{\text{FD}}(\varepsilon_{\mathbf{k}'})$, $\varepsilon_{\mathbf{k}'} = \hbar^2 k'^2 / (2m)$ [see Eq. (16.98)], m is the electron mass, with \mathbf{k}' denoting a wave vector. In terms of the density of

states per unit volume $D_F = 2^{1/2} m^{3/2} \sqrt{\epsilon_F} / (\pi^2 \hbar^3)$ at the Fermi energy ϵ_F [see Eq. (16.104)] the entropy σ can be expressed as

$$\sigma = -\mathcal{V} D_F \int_0^\infty d\epsilon \sqrt{\frac{\epsilon}{\epsilon_F}} [n \log n + (1-n) \log(1-n)] , \quad (16.289)$$

where \mathcal{V} is the volume, and

$$n(\epsilon) = \frac{1}{e^{\beta(\epsilon-\mu)} + 1} .$$

The following holds $\mu = \epsilon_F + O(T)$, hence using the variable transformation $x = \beta(\epsilon - \epsilon_F)$ in the integration one obtains to first order in T

$$\begin{aligned} \sigma &= -\frac{\mathcal{V} D_F}{\beta} \int_{-\beta\epsilon_F}^\infty dx \left[\frac{1}{e^x + 1} \log \frac{1}{e^x + 1} + \frac{1}{e^{-x} + 1} \log \frac{1}{e^{-x} + 1} \right] \\ &\simeq -\frac{\mathcal{V} D_F}{\beta} \int_{-\infty}^\infty dx \left[\frac{1}{e^x + 1} \log \frac{1}{e^x + 1} + \frac{1}{e^{-x} + 1} \log \frac{1}{e^{-x} + 1} \right] \\ &= -\frac{\mathcal{V} D_F}{\beta} \left(-\frac{\pi^2}{3} \right) , \end{aligned} \quad (16.290)$$

hence

$$\sigma = \frac{\pi^2 \mathcal{V} D_F}{3\beta} + O(T^2) . \quad (16.291)$$

19. Let $V_d(R)$ be the volume of a d -dimensional sphere of radius R . The volume $V_d(R)$ is related to the volume $V_{d-1}(R)$ by

$$\begin{aligned} V_d(R) &= \int_{\sum_{n=1}^d k_n^2 \leq R^2} dk_1 dk_2 \times \cdots \times dk_d \\ &= \int_{-R}^R dk_d \int_{\sum_{n=1}^{d-1} k_n^2 \leq R^2 - k_d^2} dk_1 \times \cdots \times dk_{d-1} \\ &= \int_{-R}^R dk V_{d-1}(\sqrt{R^2 - k^2}) \\ &= R \int_{-1}^1 dq V_{d-1}(R\sqrt{1 - q^2}) . \end{aligned} \quad (16.292)$$

The recursive relation (16.292) together with $V_1(R) = 2R$ yield

$$V_2(R) = 2R^2 \int_{-1}^1 dq \sqrt{1 - q^2} = \pi R^2 , \quad (16.293)$$

$$V_3(R) = \pi R^3 \int_{-1}^1 dq (1 - q^2) = \frac{4\pi R^3}{3}, \quad (16.294)$$

and

$$V_4(R) = \frac{4\pi R^4}{3} \int_{-1}^1 dq (1 - q^2)^{3/2} = \frac{\pi^2 R^4}{2}. \quad (16.295)$$

For the general case

$$V_d(R) = \frac{\pi^{d/2} R^d}{\Gamma\left(\frac{d}{2} + 1\right)}, \quad (16.296)$$

where Γ is Euler's gamma function. With the help of Eq. (16.296) one finds that [see Eqs. (16.102) and (16.104)]

$$\begin{aligned} D_d(\epsilon) &= \frac{d}{d\epsilon} \frac{1}{(2\pi)^d} \frac{\pi^{d/2} \left(\frac{\sqrt{2m\epsilon}}{\hbar}\right)^d}{\Gamma\left(\frac{d}{2} + 1\right)} \\ &= \frac{d}{2\Gamma\left(\frac{d}{2} + 1\right)} \frac{\left(\frac{m\epsilon}{2\pi\hbar^2}\right)^{d/2}}{\epsilon}. \end{aligned} \quad (16.297)$$

For the cases $d = 1$, $d = 2$ and $d = 3$, Eq. (16.297) yields

$$D_1(\epsilon) = \frac{\sqrt{2m\epsilon}^{-1/2}}{2\pi\hbar}, \quad (16.298)$$

$$D_2(\epsilon) = \frac{m}{2\pi\hbar^2}, \quad (16.299)$$

$$D_3(\epsilon) = \frac{\sqrt{2}m^{3/2}\sqrt{\epsilon}}{2\pi^2\hbar^3}. \quad (16.300)$$

17. Open Quantum Systems

This chapter is mainly based on the book [7].

17.1 Classical Resonator

Consider a *classical* mechanical resonator having mass m and resonance frequency ω_0 . The resonator is driven by an external force F_{ex} that is given by

$$F_{\text{ex}} = F_0 \cos(\omega_p t) = F_0 \operatorname{Re}(e^{-i\omega_p t}) , \quad (17.1)$$

where F_0 is a real constant. The equation of motion is given by

$$m\ddot{x} + m\omega_0^2 x = F_{\text{ex}} . \quad (17.2)$$

In steady state we seek a solution having the form

$$x = \operatorname{Re}(Ae^{-i\omega_p t}) , \quad (17.3)$$

where A is a complex constant. Substituting such a solution into the equation of motion (17.2) yields

$$A = \frac{1}{m} \frac{F_0}{\omega_0^2 - \omega_p^2} . \quad (17.4)$$

This result is clearly unphysical since it diverges at resonance $\omega_p = \omega_0$. This can be fixed by introducing a damping term in the equation of motion

$$m\ddot{x} + m\gamma\dot{x} + m\omega_0^2 x = F_{\text{ex}} , \quad (17.5)$$

where γ is the damping rate. For this case the steady state amplitude becomes finite for any driving frequency

$$A = \frac{1}{m} \frac{F_0}{\omega_0^2 - \omega_p^2 - i\omega_p\gamma} . \quad (17.6)$$

However, also (17.5) is a unphysical equation of motion. The equipartition theorem of classical statistical mechanics predicts that in equilibrium at temperature T the following holds

$$\langle x^2 \rangle = \frac{k_B T}{m\omega_0^2}. \quad (17.7)$$

However, as can be seen from Eq. (17.5), when $F_0 = 0$ the steady state solution is given by $x(t) = 0$, contradicting thus the equipartition theorem. This can be fixed by introducing yet another term $f(t)$ in the equation of motion representing *fluctuating* force

$$m\ddot{x} + m\gamma\dot{x} + m\omega_0^2 x = f(t) + F_{\text{ex}}. \quad (17.8)$$

The fluctuating force has vanishing mean $\langle f(t) \rangle = 0$, however its variance is finite $\langle f^2(t) \rangle > 0$. In exercise 1 below the autocorrelation function of the fluctuating force $f(t)$ is found to be given by (17.258)

$$\langle f(t) f(t+t') \rangle = 2m\gamma k_B T \delta(t'). \quad (17.9)$$

Similarly to the classical case, also in the quantum case unphysical behavior is obtained when damping is disregarded. This happens not only for the above discussed example of a driven resonator. For example, recall that for a general quantum system driven by a periodic perturbation the time dependent perturbation theory predicts in the long time limit constant rates of transition between states [e.g., see Eq. (10.39)]. Such a prediction can yield correct steady state population of quantum states only when damping is taken into account.

Damping and fluctuation in a quantum system can be taken into account by introducing a thermal bath, which is assumed to be weakly coupled to the system under study. Below this technique is demonstrated for two cases. In the first one, the system under study (also referred to as the closed system) is a mechanical resonator, and in the second one it is taken to be a two level system. In both cases the open system is modeled by assuming that the closed system is coupled to a thermal bath in thermal equilibrium.

17.2 Quantum Resonator Coupled to Thermal Bath

Consider a mechanical resonator having mass m and resonance frequency ω_0 . The resonator is coupled to a thermal bath, which is modeled as an ensemble of harmonic oscillators.

17.2.1 The closed System

First, we consider the isolated resonator. The Hamiltonian is given by [see Eqs. (5.9), (5.10), (5.11), (5.12), (5.13) and (5.16)]

$$\begin{aligned}\mathcal{H}_0 &= \frac{p^2}{2m} + \frac{1}{2}m\omega_0^2x^2 \\ &= \hbar\omega_0 \left(a^\dagger a + \frac{1}{2} \right),\end{aligned}\tag{17.10}$$

where

$$a = \sqrt{\frac{m\omega_0}{2\hbar}} \left(x + \frac{ip}{m\omega_0} \right),\tag{17.11}$$

$$a^\dagger = \sqrt{\frac{m\omega_0}{2\hbar}} \left(x - \frac{ip}{m\omega_0} \right),\tag{17.12}$$

and where

$$[a, a^\dagger] = 1.\tag{17.13}$$

The inverse transformation is

$$x = \sqrt{\frac{\hbar}{2m\omega_0}} (a^\dagger + a),\tag{17.14}$$

$$p = i\sqrt{\frac{m\hbar\omega_0}{2}} (a^\dagger - a).\tag{17.15}$$

17.2.2 Coupling to Thermal Bath

Damping is taken into account using a model containing a reservoir of harmonic oscillators interacting with the resonator. The total Hamiltonian is given by

$$\mathcal{H}_t = \mathcal{H}_0 + \mathcal{H}_r + \mathcal{V},\tag{17.16}$$

where \mathcal{H}_0 is given by Eq. (17.10), \mathcal{H}_r is the Hamiltonian of the thermal bath, which is assumed to be a dense ensemble of harmonic oscillators

$$\mathcal{H}_r = \sum_k \hbar\omega_k \left(b_k^\dagger b_k + \frac{1}{2} \right),\tag{17.17}$$

and \mathcal{V} is a coupling term

$$\mathcal{V} = a\hbar \sum_k \lambda_k b_k^\dagger + a^\dagger \hbar \sum_k \lambda_k^* b_k,\tag{17.18}$$

where λ_k are coupling constants. The bath operators satisfy regular harmonic oscillator commutation relations

$$[a, b_k] = [a, b_k^\dagger] = [a^\dagger, b_k] = [a^\dagger, b_k^\dagger] = 0,\tag{17.19}$$

$$[b_k, b_l^\dagger] = \delta_{k,l} , \quad (17.20)$$

and

$$[b_k, b_l] = [b_k^\dagger, b_l^\dagger] = 0 . \quad (17.21)$$

Exercise 17.2.1. Show that

$$\dot{a} + (i\omega_0 + \gamma)a = F(t) , \quad (17.22)$$

where γ is a constant and where the fluctuating term $F(t)$ is given by

$$F(t) = -i \sum_k \lambda_k^* \exp(-i\omega_k t) b_k(0) . \quad (17.23)$$

Solution 17.2.1. In general, the Heisenberg equation of motion of an operator O is given by Eq. (4.37)

$$\dot{O} = -\frac{i}{\hbar} [O, \mathcal{H}] + \frac{\partial O}{\partial t} . \quad (17.24)$$

Using Eq. (17.24) one finds

$$\dot{a} = -i\omega_0 a - i \sum_k \lambda_k^* b_k , \quad (17.25)$$

$$\dot{a}^\dagger = i\omega_0 a^\dagger + i \sum_k \lambda_k b_k^\dagger , \quad (17.26)$$

$$\dot{b}_k = -i\omega_k b_k - i\lambda_k a , \quad (17.27)$$

and

$$\dot{b}_k^\dagger = i\omega_k b_k^\dagger + i\lambda_k^* a^\dagger . \quad (17.28)$$

The solution of Eq. (17.27) is given by

$$\begin{aligned} b_k(t) &= \exp[-i\omega_k(t-t_0)] b_k(t_0) \\ &\quad - i\lambda_k \int_{t_0}^t dt' \exp[-i\omega_k(t-t')] a(t') . \end{aligned} \quad (17.29)$$

Choosing the initial time to be given by $t_0 = 0$ and substituting Eq. (17.29) into Eq. (17.25) yield

$$\begin{aligned} \dot{a} + i\omega_0 a + \int_0^t dt' a(t') \sum_k |\lambda_k|^2 \exp[-i\omega_k(t-t')] \\ = -i \sum_k \lambda_k^* \exp(-i\omega_k t) b_k(0) . \end{aligned} \quad (17.30)$$

The states of the thermal bath are assumed to be very dense, thus one can replace the sum over k with an integral

$$\begin{aligned} & \sum_k |\lambda_k|^2 \exp[-i\omega_k(t-t')] \\ & \simeq \int_{-\infty}^{\infty} d\Omega |\lambda(\Omega)|^2 \exp[-i\Omega(t-t')] , \end{aligned} \tag{17.31}$$

where $\lambda(\Omega)$ is the density of states. Assuming $\lambda(\Omega)$ is a smooth function near $\Omega = \omega_0$ one finds that

$$\begin{aligned} & \int_0^t dt' a(t') \sum_k |\lambda_k|^2 \exp[-i\omega_k(t-t')] \\ & \simeq \int_0^t dt' a(t') |\lambda(\omega_0)|^2 \underbrace{\int_{-\infty}^{\infty} d\Omega \exp[-i\Omega(t-t')] }_{2\pi\delta(t-t')} \\ & = \pi |\lambda(\omega_0)|^2 a(t) . \end{aligned} \tag{17.32}$$

Thus using the notation

$$\gamma = \pi |\lambda(\omega_0)|^2 , \tag{17.33}$$

one has

$$\dot{a} + (i\omega_0 + \gamma) a = F(t) , \tag{17.34}$$

$$\dot{a}^\dagger + (-i\omega_0 + \gamma) a^\dagger = F^\dagger(t) , \tag{17.35}$$

where

$$F(t) = -i \sum_k \lambda_k^* \exp(-i\omega_k t) b_k(0) , \tag{17.36}$$

$$F^\dagger(t) = i \sum_k \lambda_k \exp(i\omega_k t) b_k^\dagger(0) . \tag{17.37}$$

The fluctuation terms $F(t)$ and $F^\dagger(t)$ represent noisy force acting on the resonator.

From Eqs. (17.34), (17.35), (17.14), and (17.15) one finds that

$$\dot{p} + \gamma p + m\omega_0^2 x = f(t) , \tag{17.38}$$

where

$$f(t) = i\sqrt{\frac{m\hbar\omega_0}{2}} [F^\dagger(t) - F(t)]. \quad (17.39)$$

In classical mechanics the momentum p is given by $p = m\dot{x}$. Using this substitution the equation of motion for the quantum operator p (17.38) takes a form analogous to the classical equation of motion of a mechanical resonator having damping rate γ and influenced by a force $f(t)$

$$m\ddot{x} + m\gamma\dot{x} + m\omega_0^2 x = f(t). \quad (17.40)$$

17.2.3 Thermal Equilibrium

Exercise 17.2.2. Show that

$$\langle F^\dagger(t) F(t+t') \rangle = 2\gamma \hat{n}_0 \delta(t'), \quad (17.41)$$

$$\langle F(t) F^\dagger(t+t') \rangle = 2\gamma (\hat{n}_0 + 1) \delta(t'), \quad (17.42)$$

and

$$\langle F(t) F(t+t') \rangle = \langle F^\dagger(t) F^\dagger(t+t') \rangle = 0, \quad (17.43)$$

where

$$\hat{n}_0 = \frac{1}{e^{\beta\hbar\omega_0} - 1}, \quad (17.44)$$

and where $\beta = 1/(k_B T)$.

Solution 17.2.2. The modes of the thermal bath are assumed to be in thermal equilibrium. In general, thermal averaging of an operator O_k , associated with mode $\#k$ in the thermal bath, is given by [see Eqs. (8.10) and (8.36)]

$$\langle O_k \rangle = \text{Tr}(\rho_k O_k), \quad (17.45)$$

where the density operator ρ_k is given by

$$\rho_k = \frac{1}{Z} e^{-\beta \mathcal{H}_{r,k}}, \quad (17.46)$$

where

$$Z = \text{Tr}(e^{-\beta \mathcal{H}_{r,k}}), \quad (17.47)$$

$$\mathcal{H}_{r,k} = \hbar\omega_k \left(b_k^\dagger b_k + \frac{1}{2} \right), \quad (17.48)$$

and $\beta = 1/(k_B T)$. Using these expressions one finds that [see Eq. (8.251)]

$$\langle b_k^\dagger(t) b_k(t) \rangle = \frac{1}{e^{\beta\hbar\omega_k} - 1} \equiv \hat{n}_k. \quad (17.49)$$

Using Eq. (17.20) one finds that

$$\langle b_k(t) b_k^\dagger(t) \rangle = \hat{n}_k + 1 . \quad (17.50)$$

In a similar way one also finds that

$$\langle b_k \rangle = \langle b_k^\dagger \rangle = \langle b_k^2 \rangle = \langle b_k^{\dagger 2} \rangle = 0 . \quad (17.51)$$

Moreover, using the full bath Hamiltonian \mathcal{H}_r one can easily show that

$$\langle b_k b_l \rangle = \langle b_k^\dagger b_l^\dagger \rangle = 0 , \quad (17.52)$$

$$\langle b_k^\dagger(t) b_l(t) \rangle = \delta_{kl} \hat{n}_k , \quad (17.53)$$

and

$$\langle b_k(t) b_l^\dagger(t) \rangle = \delta_{kl} (\hat{n}_k + 1) . \quad (17.54)$$

The fluctuating forces are given by Eqs. (17.36) and (17.37). We calculate below some correlation functions of these forces. Using Eq. (17.51) one finds

$$\langle F(t) \rangle = \langle F^\dagger(t) \rangle = 0 . \quad (17.55)$$

Using Eq. (17.53) one finds that

$$\langle F^\dagger(t) F(t+t') \rangle = \sum_k |\lambda_k|^2 \exp(-i\omega_k t') \hat{n}_k . \quad (17.56)$$

Replacing the sum over k with an integral, as in Eq. (17.31), and taking into account only modes that are nearly resonant with the cavity mode one finds

$$\langle F^\dagger(t) F(t+t') \rangle = 2\gamma \hat{n}_0 \delta(t') , \quad (17.57)$$

where

$$\hat{n}_0 = \frac{1}{e^{\beta\hbar\omega_0} - 1} . \quad (17.58)$$

Similarly

$$\langle F(t) F^\dagger(t+t') \rangle = 2\gamma (\hat{n}_0 + 1) \delta(t') , \quad (17.59)$$

and

$$\langle F(t) F(t+t') \rangle = \langle F^\dagger(t) F^\dagger(t+t') \rangle = 0 . \quad (17.60)$$

Exercise 17.2.3. Show that the expectation value $\langle a^\dagger a \rangle$ in steady state is given by

$$\langle a^\dagger a \rangle = \hat{n}_0 . \quad (17.61)$$

Solution 17.2.3. Multiplying Eq. (17.34) by the integration factor $e^{(i\omega_0+\gamma)t}$ yields

$$\frac{d}{dt} \left(a e^{(i\omega_0+\gamma)t} \right) = F(t) e^{(i\omega_0+\gamma)t} . \quad (17.62)$$

The solution is given by

$$a(t) = a(t_0) e^{(i\omega_0+\gamma)(t_0-t)} + \int_{t_0}^t dt' F(t') e^{(i\omega_0+\gamma)(t'-t)} . \quad (17.63)$$

Steady state is established when $\gamma(t-t_0) \gg 1$. In this limit the first term becomes exponentially small (recall that γ is positive), i.e. effect of initial condition on the value of a at time t_0 becomes negligible. Thus in steady state the solution becomes

$$a(t) = \int_{t_0}^t dt' F(t') e^{(i\omega_0+\gamma)(t'-t)} , \quad (17.64)$$

and the Hermitian conjugate is given by

$$a^\dagger(t) = \int_{t_0}^t dt' F^\dagger(t') e^{(-i\omega_0+\gamma)(t'-t)} . \quad (17.65)$$

With the help of Eq. (17.57) one finds that

$$\begin{aligned} \langle a^\dagger a \rangle &= \int_{t_0}^t dt' \int_{t_0}^t dt'' \langle F^\dagger(t'') F(t') \rangle e^{(-i\omega_0+\gamma)(t''-t)} e^{(i\omega_0+\gamma)(t'-t)} \\ &= 2\gamma \hat{n}_0 \int_{t_0}^t dt' e^{2\gamma(t'-t)} \\ &= \hat{n}_0 \left(1 - e^{-2\gamma(t-t_0)} \right) . \end{aligned} \quad (17.66)$$

The assumption $\gamma(t-t_0) \gg 1$ allows writing this result as

$$\langle a^\dagger a \rangle = \hat{n}_0 . \quad (17.67)$$

The last result $\langle a^\dagger a \rangle = \hat{n}_0$ verifies that the resonator reached thermal equilibrium in steady state. Similarly, the next exercise shows that in the classical limit the equipartition theorem of classical statistical mechanics is satisfied.

Exercise 17.2.4. Calculate $\langle x^2 \rangle$ in steady state.

Solution 17.2.4. According to Eq. (17.14) and $[a, a^\dagger] = 1$ the following holds

$$\begin{aligned}
\langle x^2 \rangle &= \frac{\hbar}{2m\omega_0} \langle (a^\dagger + a)(a^\dagger + a) \rangle \\
&= \frac{\hbar}{2m\omega_0} \langle a^{\dagger 2} + a^2 + a^\dagger a + a a^\dagger \rangle \\
&= \frac{\hbar}{2m\omega_0} \langle a^{\dagger 2} + a^2 + 2a^\dagger a + 1 \rangle .
\end{aligned}
\tag{17.68}$$

As can be seen from Eq. (17.60), $\langle a^{\dagger 2} \rangle = \langle a^2 \rangle = 0$. Thus, with the help of Eq. (17.67) one has

$$\begin{aligned}
\langle x^2 \rangle &= \frac{\hbar}{2m\omega_0} (2\hat{n}_0 + 1) \\
&= \frac{\hbar}{2m\omega_0} \coth \frac{\beta\hbar\omega_0}{2} ,
\end{aligned}
\tag{17.69}$$

in agreement with Eq. (8.259). In the classical limit where $k_B T \gg \hbar\omega_0$ one has

$$\langle x^2 \rangle = \frac{k_B T}{m\omega_0^2} ,
\tag{17.70}$$

in agreement with the classical equipartition theorem.

17.3 Two Level System Coupled to Thermal Bath

In this section we discuss a two level system (TLS) coupled to thermal baths, and obtain the Bloch equations.

17.3.1 The Closed System

The Hamiltonian \mathcal{H}_q of the closed system can be represented by a 2×2 matrix [see Eq. (15.49)], which in turn can be expressed in terms of Pauli matrices (6.137)

$$\mathcal{H}_q \doteq \frac{\hbar}{2} \Omega(t) \cdot \boldsymbol{\sigma} ,
\tag{17.71}$$

where $\Omega(t)$ is a 3D real vector, and where the components of the Pauli matrix vector $\boldsymbol{\sigma}$ are given by

$$\sigma_x = \begin{pmatrix} 0 & 1 \\ 1 & 0 \end{pmatrix}, \quad \sigma_y = \begin{pmatrix} 0 & -i \\ i & 0 \end{pmatrix}, \quad \sigma_z = \begin{pmatrix} 1 & 0 \\ 0 & -1 \end{pmatrix} .
\tag{17.72}$$

Let $\mathbf{P} = \langle \boldsymbol{\sigma} \rangle$ be the vector of expectation values

$$\mathbf{P} = (\langle \sigma_x \rangle, \langle \sigma_y \rangle, \langle \sigma_z \rangle) . \quad (17.73)$$

We refer to this vector as the polarization vector. With the help of Eq. (4.38), which is given by

$$\frac{d\langle A \rangle}{dt} = \frac{1}{i\hbar} \langle [A, \mathcal{H}] \rangle + \left\langle \frac{\partial A}{\partial t} \right\rangle , \quad (17.74)$$

and Eq. (6.138) one finds that

$$\begin{aligned} \frac{dP_z}{dt} &= \frac{1}{i\hbar} \langle [\sigma_z, \mathcal{H}_q] \rangle \\ &= \frac{1}{2i} (\Omega_x \langle [\sigma_z, \sigma_x] \rangle + \Omega_y \langle [\sigma_z, \sigma_y] \rangle) \\ &= (\Omega_x \langle \sigma_y \rangle - \Omega_y \langle \sigma_x \rangle) \\ &= (\boldsymbol{\Omega} \times \mathbf{P}) \cdot \hat{\mathbf{z}} . \end{aligned} \quad (17.75)$$

Similar expressions are obtained for P_x and P_y that together can be written in a vector form as [see also Eq. (6.198)]

$$\frac{d\mathbf{P}}{dt} = \boldsymbol{\Omega}(t) \times \mathbf{P} . \quad (17.76)$$

The time varying 'effective magnetic field' $\boldsymbol{\Omega}(t)$ is taken to be given by

$$\boldsymbol{\Omega}(t) = \omega_0 \hat{\mathbf{z}} + \boldsymbol{\omega}_1(t) . \quad (17.77)$$

While ω_0 , which is related to the energy gap Δ separating the TLS states by $\omega_0 = \Delta/\hbar$, is assumed to be stationary, the vector $\boldsymbol{\omega}_1(t)$ is allowed to vary in time, however, it is assumed that $|\boldsymbol{\omega}_1(t)| \ll \omega_0$.

17.3.2 Coupling to Thermal Baths

As we did in the previous section, damping is taken into account using a model containing reservoirs having dense spectrum of oscillator modes interacting with the TLS. Furthermore, since the ensembles are assumed to be dense, summation over modes is done with continuous integrals. The Hamiltonian \mathcal{H} of the entire system is taken to be given by

$$\begin{aligned}
 \mathcal{H} &= \mathcal{H}_q \\
 &+ \int d\omega \hbar \omega a_1^\dagger(\omega) a_1(\omega) \\
 &+ \int d\omega \hbar \omega a_2^\dagger(\omega) a_2(\omega) \\
 &+ \hbar \int d\omega \sqrt{\frac{\Gamma_1}{2\pi}} \left(e^{i\phi_1} \sigma_+ a_1(\omega) + e^{-i\phi_1} a_1^\dagger(\omega) \sigma_- \right) \\
 &+ \hbar \int d\omega \sqrt{\frac{\Gamma_\varphi}{4\pi}} \left(e^{i\phi_2} \sigma_z a_2(\omega) + e^{-i\phi_2} a_2^\dagger(\omega) \sigma_z \right) ,
 \end{aligned} \tag{17.78}$$

where \mathcal{H}_q is the Hamiltonian for the closed TLS,

$$\sigma_+ = \begin{pmatrix} 0 & 1 \\ 0 & 0 \end{pmatrix}, \quad \sigma_- = \begin{pmatrix} 0 & 0 \\ 1 & 0 \end{pmatrix}, \tag{17.79}$$

and the real coupling parameters Γ_1 , Γ_φ , ϕ_1 and ϕ_2 are assumed to be frequency independent. The bath modes are boson modes satisfying the usual Bose commutation relations

$$[a_i(\omega), a_i^\dagger(\omega')] = \delta(\omega - \omega'), \tag{17.80}$$

$$[a_i(\omega), a_i(\omega')] = 0, \tag{17.81}$$

where $i = 1, 2$. While the coupling to the first bath (with coupling constant Γ_1) gives rise to TLS decay through spin flips, the coupling to the second bath (with coupling constant Γ_φ) gives rise to pure dephasing.

Exercise 17.3.1. Show that

$$\begin{aligned}
 \frac{d\sigma_z}{dt} &= \frac{1}{i\hbar} [\sigma_z, \mathcal{H}_q] - \Gamma_1 (1 + \sigma_z) \\
 &+ \frac{2}{\hbar} \left(-i\sigma_+ \mathcal{V}_1 + i\mathcal{V}_1^\dagger \sigma_- \right),
 \end{aligned} \tag{17.82}$$

and

$$\begin{aligned}
 \frac{d\sigma_+}{dt} &= \frac{1}{i\hbar} [\sigma_+, \mathcal{H}_q] - \left(\frac{\Gamma_1}{2} + \Gamma_\varphi \right) \sigma_+ \\
 &+ \frac{i}{\hbar} \left[-\mathcal{V}_1^\dagger \sigma_z + 2\sigma_+ (\mathcal{V}_\varphi + \mathcal{V}_\varphi^\dagger) \right],
 \end{aligned} \tag{17.83}$$

where

$$\mathcal{V}_1 = \hbar \sqrt{\frac{\Gamma_1}{2\pi}} e^{i\phi_1} \int d\omega e^{-i\omega(t-t_0)} a_1(t_0, \omega) , \quad (17.84)$$

and

$$\mathcal{V}_\varphi = \hbar \sqrt{\frac{\Gamma_\varphi}{4\pi}} e^{i\phi_2} \int d\omega e^{-i\omega(t-t_0)} a_2(t_0, \omega) . \quad (17.85)$$

Solution 17.3.1. With the help of the identities

$$[\sigma_z, \sigma_+] = 2\sigma_+ , \quad (17.86)$$

$$[\sigma_z, \sigma_-] = -2\sigma_- , \quad (17.87)$$

$$[\sigma_+, \sigma_-] = \sigma_z , \quad (17.88)$$

one finds that the Heisenberg equation of motion (4.38) for σ_z is given by

$$\begin{aligned} \frac{d\sigma_z}{dt} &= \frac{1}{i\hbar} [\sigma_z, \mathcal{H}_q] \\ &\quad - 2i \sqrt{\frac{\Gamma_1}{2\pi}} \int d\omega e^{i\phi_1} \sigma_+ a_1(\omega) \\ &\quad + 2i \sqrt{\frac{\Gamma_1}{2\pi}} \int d\omega e^{-i\phi_1} a_1^\dagger(\omega) \sigma_- , \end{aligned} \quad (17.89)$$

for σ_+ by

$$\begin{aligned} \frac{d\sigma_+}{dt} &= \frac{1}{i\hbar} [\sigma_+, \mathcal{H}_q] \\ &\quad - i \sqrt{\frac{\Gamma_1}{2\pi}} \int d\omega e^{-i\phi_1} a_1^\dagger(\omega) \sigma_z \\ &\quad + 2i \sqrt{\frac{\Gamma_\varphi}{4\pi}} \int d\omega e^{i\phi_2} \sigma_+ a_2(\omega) \\ &\quad + 2i \sqrt{\frac{\Gamma_\varphi}{4\pi}} \int d\omega e^{-i\phi_2} a_2^\dagger(\omega) \sigma_+ , \end{aligned} \quad (17.90)$$

for $a_1(\omega)$ by

$$\frac{da_1(\omega)}{dt} = -i\omega a_1(\omega) - i \sqrt{\frac{\Gamma_1}{2\pi}} e^{-i\phi_1} \sigma_- , \quad (17.91)$$

and for $a_2(\omega)$ by

$$\frac{da_2(\omega)}{dt} = -i\omega a_2(\omega) - i \sqrt{\frac{\Gamma_\varphi}{4\pi}} e^{-i\phi_2} \sigma_z . \quad (17.92)$$

Integrating the equations of motion for the bath operators $a_1(\omega)$ and $a_2(\omega)$ yields

$$\begin{aligned}
 a_1(\omega) &= e^{-i\omega(t-t_0)} a_1(t_0, \omega) \\
 &\quad - i\sqrt{\frac{\Gamma_1}{2\pi}} e^{-i\phi_1} \int_{t_0}^t dt' e^{-i\omega(t-t')} \sigma_-(t') ,
 \end{aligned} \tag{17.93}$$

and

$$\begin{aligned}
 a_2(\omega) &= e^{-i\omega(t-t_0)} a_2(t_0, \omega) \\
 &\quad - i\sqrt{\frac{\Gamma_2}{4\pi}} e^{-i\phi_2} \int_{t_0}^t dt' e^{-i\omega(t-t')} \sigma_z(t') .
 \end{aligned} \tag{17.94}$$

We now substitute these results into the Eqs. (17.89) and (17.90) and make use of the following relations

$$\int d\omega e^{-i\omega(t-t')} = 2\pi \delta(t-t') , \tag{17.95}$$

$$\int_{t_0}^t dt' \delta(t-t') f(t') = \frac{1}{2} \text{sgn}(t-t_0) f(t) . \tag{17.96}$$

where $\text{sgn}(x)$ is the sign function

$$\text{sgn}(x) = \begin{cases} +1 & \text{if } x > 0 \\ -1 & \text{if } x < 0. \end{cases} , \tag{17.97}$$

to obtain

$$\begin{aligned}
 \frac{d\sigma_z}{dt} &= \frac{1}{i\hbar} [\sigma_z, \mathcal{H}_q] \\
 &\quad - 2i\sqrt{\frac{\Gamma_1}{2\pi}} \int d\omega e^{i\phi_1} \sigma_+ e^{-i\omega(t-t_0)} a_1(t_0, \omega) \\
 &\quad - \Gamma_1 \sigma_+ \sigma_- \\
 &\quad + 2i\sqrt{\frac{\Gamma_1}{2\pi}} \int d\omega e^{-i\phi_1} e^{i\omega(t-t_0)} a_1^\dagger(t_0, \omega) \sigma_- \\
 &\quad - \Gamma_1 \sigma_+ \sigma_- ,
 \end{aligned} \tag{17.98}$$

and

$$\begin{aligned}
 \frac{d\sigma_+}{dt} &= \frac{1}{i\hbar} [\sigma_+, \mathcal{H}_q] \\
 &\quad - i\sqrt{\frac{\Gamma_1}{2\pi}} \int d\omega e^{-i\phi_1} e^{i\omega(t-t_0)} a_1^\dagger(t_0, \omega) \sigma_z \\
 &\quad + \frac{\Gamma_1}{2} \sigma_+ \sigma_z \\
 &\quad + 2i\sqrt{\frac{\Gamma_\varphi}{4\pi}} \int d\omega e^{i\phi_2} \sigma_+ e^{-i\omega(t-t_0)} a_2(t_0, \omega) \\
 &\quad + \frac{\Gamma_\varphi}{2} \sigma_+ \sigma_z \\
 &\quad + 2i\sqrt{\frac{\Gamma_\varphi}{4\pi}} \int d\omega e^{-i\phi_2} e^{i\omega(t-t_0)} a_2^\dagger(t_0, \omega) \sigma_+ \\
 &\quad - \frac{\Gamma_\varphi}{2} \sigma_z \sigma_+ .
 \end{aligned} \tag{17.99}$$

Thus, by making use of the following relations

$$\sigma_+ \sigma_- = \frac{1}{2} (1 + \sigma_z) , \tag{17.100}$$

$$\sigma_- \sigma_+ = \frac{1}{2} (1 - \sigma_z) , \tag{17.101}$$

$$\sigma_z \sigma_+ = -\sigma_+ \sigma_z = \sigma_+ , \tag{17.102}$$

one derives (17.82) and (17.83).

17.3.3 Thermal Equilibrium

Using Eq. (17.51) one finds

$$\langle \mathcal{V}_1 \rangle = \langle \mathcal{V}_1^\dagger \rangle = \langle \mathcal{V}_\varphi \rangle = \langle \mathcal{V}_\varphi^\dagger \rangle = 0 . \tag{17.103}$$

Using Eqs. (17.53) and (17.54), the relation

$$\int d\omega e^{-i\omega(t-t')} = 2\pi\delta(t-t') , \tag{17.104}$$

and assuming the case where the dominant contribution to the TLS dynamics comes from the bath modes near frequency ω_0 (recall that $\omega_0 = \Delta/\hbar$, where Δ is the energy gap separating the TLS states), one finds that

$$\begin{aligned}
 & \langle \mathcal{V}_1^\dagger(t') \mathcal{V}_1(t) \rangle \\
 &= \hbar^2 \frac{\Gamma_1}{2\pi} \int d\omega \int d\omega' e^{-i\omega'(t-t')} \langle a_1^\dagger(t_0, \omega) a_1(t_0, \omega') \rangle \\
 &= \hbar^2 \frac{\Gamma_1}{2\pi} \int d\omega e^{-i\omega(t-t')} \langle n(\omega) \rangle \\
 &\simeq \hbar^2 \Gamma_1 \hat{n}_0 \delta(t-t') ,
 \end{aligned} \tag{17.105}$$

where \hat{n}_0 is given by [see Eq. (17.58)]

$$\hat{n}_0 = \frac{1}{e^{\beta\hbar\omega_0} - 1} . \tag{17.106}$$

Similarly

$$\langle \mathcal{V}_1(t) \mathcal{V}_1^\dagger(t') \rangle = \hbar^2 \Gamma_1 (\hat{n}_0 + 1) \delta(t-t') , \tag{17.107}$$

$$\langle \mathcal{V}_\varphi^\dagger(t') \mathcal{V}_\varphi(t) \rangle = \hbar^2 \frac{\Gamma_\varphi}{2} \hat{n}_0 \delta(t-t') , \tag{17.108}$$

$$\langle \mathcal{V}_\varphi(t) \mathcal{V}_\varphi^\dagger(t') \rangle = \hbar^2 \frac{\Gamma_\varphi}{2} (\hat{n}_0 + 1) \delta(t-t') , \tag{17.109}$$

and

$$\begin{aligned}
 \langle \mathcal{V}_1(t') \mathcal{V}_1(t) \rangle &= \langle \mathcal{V}_1^\dagger(t') \mathcal{V}_1^\dagger(t) \rangle \\
 \langle \mathcal{V}_\varphi(t') \mathcal{V}_\varphi(t) \rangle &= \langle \mathcal{V}_\varphi^\dagger(t') \mathcal{V}_\varphi^\dagger(t) \rangle = 0 .
 \end{aligned} \tag{17.110}$$

17.3.4 Correlation Functions

Equation of motion for the polarization vector \mathbf{P} can be obtained by taking the expectation value of Eqs. (17.82) and (17.83). Using the identity $\sigma_\pm = (1/2)(\sigma_x \pm i\sigma_y)$ and the notation $P_\pm = (1/2)(P_x \pm iP_y)$ and $\hat{\mathbf{u}}_\pm = (1/2)(\hat{\mathbf{x}} \pm i\hat{\mathbf{y}})$ one finds that

$$\begin{aligned}
 \dot{P}_z &= (\Omega(t) \times \mathbf{P})_z - \Gamma_1 (1 + P_z) \\
 &\quad + \frac{2}{\hbar} \left(-i \langle \sigma_+ \mathcal{V}_1 \rangle + i \langle \mathcal{V}_1^\dagger \sigma_- \rangle \right) ,
 \end{aligned} \tag{17.111}$$

and

$$\begin{aligned}
 \dot{P}_+ &= (\Omega(t) \times \mathbf{P})_+ - \left(\frac{\Gamma_1}{2} + \Gamma_\varphi \right) P_+ \\
 &\quad + \frac{i}{\hbar} \left[- \langle \mathcal{V}_1^\dagger \sigma_z \rangle + 2 \left(\langle \sigma_+ \mathcal{V}_\varphi \rangle + \langle \mathcal{V}_\varphi^\dagger \sigma_+ \rangle \right) \right] ,
 \end{aligned} \tag{17.112}$$

where the subscripts z and $+$ denote the components of the vector $\Omega(t) \times \mathbf{P}$ in the $\hat{\mathbf{z}}$ and $\hat{\mathbf{u}}_+$ directions respectively. However, Eqs. (17.111) and (17.112) contain product terms between bath operators and TLS operators (e.g. the term $\langle \sigma_+ \mathcal{V}_1 \rangle$ in Eq. (17.111)). To lowest order such terms can be evaluated by assuming that these operators are independent, e.g. $\langle \sigma_+ \mathcal{V}_1 \rangle \simeq \langle \sigma_+ \rangle \langle \mathcal{V}_1 \rangle$. However, this approach, which yields vanishing contribution of all such terms is too crude. Below we employ a better approximation to evaluate the expectation value of such terms. In the first step Eqs. (17.82) and (17.83) are formally integrated. This yields the following results

$$\begin{aligned} \sigma_z(t) &= -1 + (1 + \sigma_z(0)) e^{-\Gamma_1 t} \\ &\quad + \int_0^t dt' \left[\frac{1}{i\hbar} [\sigma_z, \mathcal{H}_q] + \frac{2}{\hbar} \left(-i\sigma_+ \mathcal{V}_1 + i\mathcal{V}_1^\dagger \sigma_- \right) \right] e^{\Gamma_1(t'-t)}, \end{aligned} \quad (17.113)$$

and

$$\begin{aligned} \sigma_+(t) &= \sigma_+(0) e^{-(\frac{\Gamma_1}{2} + \Gamma_\varphi)t} \\ &\quad + \int_0^t dt' \left[\frac{1}{i\hbar} [\sigma_+, \mathcal{H}_q] + \frac{i}{\hbar} \left(-\mathcal{V}_1^\dagger \sigma_z + 2(\sigma_+ \mathcal{V}_\varphi + \mathcal{V}_\varphi^\dagger \sigma_+) \right) \right] e^{(\frac{\Gamma_1}{2} + \Gamma_\varphi)(t'-t)}. \end{aligned} \quad (17.114)$$

In the second step these expressions for the TLS operators are substituted into Eqs. (17.111) and (17.112). In this final step, correlations are disregarded (e.g. the expectation value of a term having the form $\sigma_+ \mathcal{V}_1^\dagger \mathcal{V}_1$ is evaluated using the approximation $\langle \sigma_+ \mathcal{V}_1^\dagger \mathcal{V}_1 \rangle \simeq \langle \sigma_+ \rangle \langle \mathcal{V}_1^\dagger \mathcal{V}_1 \rangle$). The expectation values of bath operators are calculated with the help of the results of the previous section. This approach yields the following results

$$\begin{aligned} \langle \sigma_+ \mathcal{V}_1 \rangle &= \frac{1}{i\hbar} \int_0^t dt' e^{(\frac{\Gamma_1}{2} + \Gamma_\varphi)(t'-t)} \langle \mathcal{V}_1^\dagger(t') \mathcal{V}_1(t) \rangle \langle \sigma_z(t') \rangle \\ &= -\frac{i\hbar\Gamma_1\hat{n}_0}{2} P_z, \end{aligned} \quad (17.115)$$

$$\langle \mathcal{V}_1^\dagger \sigma_- \rangle = \frac{i\hbar\Gamma_1\hat{n}_0}{2} P_z, \quad (17.116)$$

$$\langle \mathcal{V}_1^\dagger \sigma_z \rangle = -i\hbar\Gamma_1\hat{n}_0 P_+, \quad (17.117)$$

and

$$\langle \sigma_+ \mathcal{V}_\varphi \rangle + \langle \mathcal{V}_\varphi^\dagger \sigma_+ \rangle = i\hbar\Gamma_\varphi\hat{n}_0 P_+, \quad (17.118)$$

thus

$$\dot{P}_z = (\Omega(t) \times \mathbf{P})_z - \Gamma_1 [1 + (2\hat{n}_0 + 1) P_z], \quad (17.119)$$

and

$$\dot{P}_+ = (\Omega(t) \times \mathbf{P})_+ - \left(\frac{\Gamma_1}{2} + \Gamma_\varphi \right) (2\hat{n}_0 + 1) P_+ . \quad (17.120)$$

A similar equation can be obtained for \dot{P}_- , which together with Eq. (17.120) can be written as

$$\dot{P}_x = (\Omega(t) \times \mathbf{P})_x - \left(\frac{\Gamma_1}{2} + \Gamma_\varphi \right) (2\hat{n}_0 + 1) P_x , \quad (17.121)$$

$$\dot{P}_y = (\Omega(t) \times \mathbf{P})_y - \left(\frac{\Gamma_1}{2} + \Gamma_\varphi \right) (2\hat{n}_0 + 1) P_y . \quad (17.122)$$

17.3.5 The Bloch Equations

Consider the case where $\boldsymbol{\omega}_1(t) = 0$, i.e. $\Omega(t) = \omega_0 \hat{\mathbf{z}}$ [see Eq. (17.77)]. For this case Eqs. (17.119) and (17.120) become

$$\dot{P}_z = -\Gamma_1 [1 + (2\hat{n}_0 + 1) P_z] , \quad (17.123)$$

$$\dot{P}_\pm = \left[\pm i\omega_0 - \left(\frac{\Gamma_1}{2} + \Gamma_\varphi \right) (2\hat{n}_0 + 1) \right] P_\pm . \quad (17.124)$$

In the long time limit the solution is given by $P_\pm(t \rightarrow \infty) = 0$ and $P_z(t \rightarrow \infty) = P_{z0}$, where [see Eq. (17.58)]

$$P_{z0} = -\frac{1}{2\hat{n}_0 + 1} = -\tanh \frac{\beta \hbar \omega_0}{2} . \quad (17.125)$$

Note that Eq. (17.125) is in agreement with the Boltzmann distribution law of statistical mechanics, according to which in thermal equilibrium the probability to occupy a state having energy ϵ is proportional to $\exp(-\beta\epsilon)$ (recall that P_z is the probability to occupy the upper state of the TLS minus the probability to occupy the lower one). In terms of the decay times T_1 and T_2 , which are defined by

$$T_1 = \Gamma_1^{-1} (2\hat{n}_0 + 1)^{-1} , \quad (17.126)$$

$$T_2 = \left(\frac{\Gamma_1}{2} + \Gamma_\varphi \right)^{-1} (2\hat{n}_0 + 1)^{-1} , \quad (17.127)$$

the equations of motion for the general case, which are known as optical Bloch equations, are given by

$$\dot{P}_x = (\Omega(t) \times \mathbf{P})_x - \frac{P_x}{T_2} , \quad (17.128)$$

$$\dot{P}_y = (\Omega(t) \times \mathbf{P})_y - \frac{P_y}{T_2} , \quad (17.129)$$

$$\dot{P}_z = (\Omega(t) \times \mathbf{P})_z - \frac{P_z - P_{z0}}{T_1} . \quad (17.130)$$

Exercise 17.3.2. The relations (17.126) and (17.127) imply that

$$T_2^{-1} = \frac{T_1^{-1}}{2} + \Gamma_\varphi (2\hat{n}_0 + 1) \geq \frac{T_1^{-1}}{2}. \quad (17.131)$$

Show that the same bound (17.131) can be deduced using only the Bloch equations (17.128), (17.129) and (17.130).

Solution 17.3.2. For the case $\Omega(t) = 0$, the Bloch equations (17.128), (17.129) and (17.130) yield

$$\begin{aligned} \frac{d|\mathbf{P}|^2}{dt} &= 2\mathbf{P} \cdot \frac{d\mathbf{P}}{dt} \\ &= -\frac{P_x^2 + P_y^2}{T_2} - \frac{P_z(P_z - P_{z0})}{T_1}. \end{aligned} \quad (17.132)$$

On the surface of the Bloch sphere, i.e. for $|\mathbf{P}|^2 = P_x^2 + P_y^2 + P_z^2 = 1$, one has

$$\frac{d|\mathbf{P}|^2}{dt} = -\frac{1 - P_z^2}{T_2} - \frac{P_z(P_z - P_{z0})}{T_1}. \quad (17.133)$$

The requirement that $d|\mathbf{P}|^2/dt \leq 0$ on the sphere's surface leads to (recall that $P_z \in [-1, 1]$, hence $1 - P_z^2 \geq 0$)

$$\frac{2T_1}{T_2} \geq f(P_z, P_{z0}), \quad (17.134)$$

where

$$f(P_z, P_{z0}) = -\frac{2P_z(P_z - P_{z0})}{1 - P_z^2}. \quad (17.135)$$

For any given $P_{z0} \in (-1, 1)$, the function $f(P_z, P_{z0})$ peaks at the point

$$P_z = P_{z,p} \equiv \frac{1 - \sqrt{1 - P_{z0}^2}}{P_{z0}}, \quad (17.136)$$

and the following holds (note that $|P_{z,p}| \in (-1, 1)$)

$$f(P_{z,p}, P_{z0}) = 1 - \sqrt{1 - P_{z0}^2}. \quad (17.137)$$

The bound (17.131) is obtained for $P_{z0}^2 \rightarrow 1$.

17.4 Problems

1. Calculate the autocorrelation function $\langle f(t) f(t+t') \rangle$ of the *classical* fluctuating force $f(t)$, which was introduced into the classical equation of motion (17.8) of a mechanical resonator. The autocorrelation function should yield a result consisting with the equipartition theorem.
2. Calculate the autocorrelation function $\langle f(t) f(t+t') \rangle$, where the *quantum* operator $f(t)$ is given by Eq. (17.39).
3. Consider a one-dimensional mechanical resonator having mass m , resonance frequency ω_0 and damping rate γ in thermal equilibrium at temperature T . Calculate the expectation value of the autocorrelation function $g(\tau)$ of the resonator's coordinate x , which is defined by

$$g(\tau) = \frac{1}{2} \langle x(t) x(t+\tau) + x(t+\tau) x(t) \rangle, \quad (17.138)$$

in steady state.

4. Consider a TLS having energy gap Δ . A perturbation, which is externally applied, induces transitions between the states having rate Γ_T . Calculate the polarization vector \mathbf{P} in steady state.
5. **Overlapping resonances** - The Hamiltonian \mathcal{H}_a of a two-level atom is expressed as $\hbar^{-1}\mathcal{H}_a = \omega_1 |\varphi_1\rangle \langle \varphi_1| + \omega_2 |\varphi_2\rangle \langle \varphi_2|$. The atom is coupled to a system having a continuous spectrum, whose Hamiltonian is expressed as $\hbar^{-1}\mathcal{H}_b = \int_{-\infty}^{\infty} d\omega' \omega' |\omega'\rangle \langle \omega'|$. The total Hamiltonian is given by $\mathcal{H} = \mathcal{H}_a + \mathcal{H}_b + V$. The non-vanishing matrix elements of V are denoted by

$$\langle \varphi_1 | V | \varphi_2 \rangle = \hbar \eta, \quad (17.139)$$

$$\langle \omega | V | \varphi_1 \rangle = \frac{\hbar \gamma_1^{1/2}}{\sqrt{2\pi}}, \quad (17.140)$$

$$\langle \omega | V | \varphi_2 \rangle = \frac{\hbar \gamma_2^{1/2}}{\sqrt{2\pi}}, \quad (17.141)$$

and it is assumed that $\langle \varphi_1 | \hat{V} | \varphi_1 \rangle = \langle \varphi_2 | \hat{V} | \varphi_2 \rangle = 0$ and $\langle \omega' | \hat{V} | \omega \rangle = 0$. Moreover, it is assumed that both γ_1 and γ_2 are ω independent. The vector state of the system $|\Psi(t)\rangle$ is expressed as

$$|\Psi(t)\rangle = a_1(t) |\varphi_1\rangle + a_2(t) |\varphi_2\rangle + \int_{-\infty}^{\infty} d\omega'' b_{\omega''}(t) e^{-i\omega''t} |\omega''\rangle. \quad (17.142)$$

Derive equations of motion for the coefficients $a_1(t)$ and $a_2(t)$.

6. **Magnetic resonance** - A time dependent magnetic field given by

$$\mathbf{B}(t) = B_0 \hat{\mathbf{z}} + B_1 (\hat{\mathbf{x}} \cos(\omega t) + \hat{\mathbf{y}} \sin(\omega t)) \quad (17.143)$$

is applied to a spin 1/2 particle.

- a) Use the Bloch equations to determine the polarization P_z in steady state.

b) The polarization P_x in steady state can be expressed as

$$P_x = 2\omega_1 [\cos(\omega t) \chi'(\omega) + \sin(\omega t) \chi''(\omega)] , \quad (17.144)$$

where $\chi'(\omega)$ and $\chi''(\omega)$ are respectively the real and imaginary parts of the magnetic susceptibility $\chi(\omega)$ (i.e. $\chi(\omega) = \chi'(\omega) + i\chi''(\omega)$). Note that the term proportional to $\chi'(\omega)$ is 'in phase' with respect to the driving magnetic field in the x direction [recall that $B_x = B_1 \cos(\omega t)$], whereas the second term, which is proportional to $\chi''(\omega)$ is 'out of phase' [i.e. proportional to $\sin(\omega t)$] with respect to B_x . Calculate $\chi(\omega)$.

7. **Mollow triplet** - The Bloch equations (17.296) and (17.297) can be written in a matrix form as

$$\dot{\mathcal{P}} = M\mathcal{P} + \mathcal{P}_0 , \quad (17.145)$$

where

$$\mathcal{P} = \begin{pmatrix} P_{R+} \\ P_{R-} \\ P_z \end{pmatrix} , \quad \mathcal{P}_0 = \begin{pmatrix} 0 \\ 0 \\ \frac{P_{z0}}{T_1} \end{pmatrix} , \quad (17.146)$$

the matrix M is given by

$$M = \begin{pmatrix} i\Delta - \frac{1}{T_2} & 0 & i\omega_1 \\ 0 & -i\Delta - \frac{1}{T_2} & -i\omega_1 \\ \frac{i\omega_1}{2} & -\frac{i\omega_1}{2} & -\frac{1}{T_1} \end{pmatrix} , \quad (17.147)$$

and $\Delta = \omega - \omega_0$. Consider a perturbation added to Eq. (17.145), which becomes

$$\dot{\mathcal{P}} = M\mathcal{P} + \mathcal{P}_0 + \mathcal{V} , \quad (17.148)$$

where the vector \mathcal{V} is given by $\mathcal{V} = (ve^{i\delta t}, v^*e^{-i\delta t}, 0)^T$, and where both v and the real δ are constants. Calculate the polarization P_z in steady state.

8. **fluctuating magnetic field** - A magnetic field \mathbf{B} given by

$$\gamma_e \mathbf{B}(t) = \omega_0 \hat{\mathbf{z}} + \omega_x(t) \hat{\mathbf{x}} + \omega_y(t) \hat{\mathbf{y}} + \omega_z(t) \hat{\mathbf{z}} , \quad (17.149)$$

where $\gamma_e = 2\pi \times 28.03 \text{ GHz T}^{-1}$ is the electron spin gyromagnetic ratio [see Eq. (2.91)], is applied to a spin 1/2 particle. While the angular Larmor frequency ω_0 is a constant, the components $\omega_x(t)$, $\omega_y(t)$ and $\omega_z(t)$ represent the effect of a fluctuating magnetic field. The following is assumed to hold

$$\langle \omega_x \rangle = \langle \omega_y \rangle = \langle \omega_z \rangle = 0 , \quad (17.150)$$

where $\langle \rangle$ denotes time averaging (i.e. the fluctuating field had a vanishing averaged value), and the correlation function $\langle \omega_i(t) \omega_j(t') \rangle$ is given by

$$\langle \omega_i(t) \omega_j(t') \rangle = \delta_{ij} \omega_s^2 \exp\left(-\frac{|t-t'|}{\tau_s}\right), \quad (17.151)$$

where both the variance ω_s^2 and the correlation time τ_s are positive constants, and where $i, j \in \{x, y, z\}$. Disregard coupling to an environment. Find an equation of motion for the vector of expectation values $\mathbf{P} = (\langle \sigma_x \rangle, \langle \sigma_y \rangle, \langle \sigma_z \rangle)$ (17.73).

9. A dilute gas of hydrogen atoms at temperature T is illuminated by a laser having intensity I_L (in units of power per unit area), circular polarization and an angular frequency ω that is tuned close to the transition angular frequency ω_0 from the ground state $|n=1, l=0, m=0\rangle$ to the excited state $|n=2, l=1, m=1\rangle$. The atoms are characterized by longitudinal T_1 and transverse T_2 relaxation times. Calculate the probability p_e in steady state to find an atom in the excited state.
10. **Lindbladian** - The Lindblad master equation for a two-level system is given by

$$\begin{aligned} \frac{d\rho}{dt} = & i\hbar^{-1} [\rho, \mathcal{H}] \\ & + \frac{(\hat{n}_0 + 1) \Gamma_1}{4} \mathcal{D}_\rho(\sigma_-) + \frac{\hat{n}_0 \Gamma_1}{4} \mathcal{D}_\rho(\sigma_+) \\ & + \frac{(2\hat{n}_0 + 1) \Gamma_\varphi}{2} \mathcal{D}_\rho(\sigma_z), \end{aligned} \quad (17.152)$$

where the 2×2 density matrix ρ is expressed as

$$\rho = \frac{1 + \mathbf{k} \cdot \boldsymbol{\sigma}}{2}, \quad (17.153)$$

where $\mathbf{k} = (k_x, k_y, k_z)$ is a real vector, the Hamiltonian matrix \mathcal{H} is given by

$$\hbar^{-1} \mathcal{H} = \frac{\boldsymbol{\omega} \cdot \boldsymbol{\sigma}}{2}, \quad (17.154)$$

where $\boldsymbol{\omega} = (\omega_x, \omega_y, \omega_z)$ is a real vector, the damping rates Γ_1 and Γ_φ are positive, the Lindbladian $\mathcal{D}_\rho(X)$ for an operator X is given by

$$\mathcal{D}_\rho(X) = X\rho X^\dagger - \frac{X^\dagger X\rho + \rho X^\dagger X}{2}, \quad (17.155)$$

the matrices σ_- and σ_+ are given by $\sigma_\pm = \sigma_x \pm i\sigma_y$, the thermal occupation factor \hat{n}_0 is given by Eq. (17.106), and σ_x, σ_y and σ_z are Pauli matrices (6.137). Derive an equation of motion for \mathbf{k} .

11. **Non-Hermitian master equation** - Consider a density operator ρ evolving in time according to the following master equation

$$\frac{d\rho}{dt} = i\hbar^{-1}[\rho, \mathcal{H}] + \gamma(\rho S + S\rho - 2\rho\langle S \rangle) , \quad (17.156)$$

where $\mathcal{H} = \mathcal{H}^\dagger$ is a time-independent Hamiltonian [compare with Eq. (8.29)], γ is real, $S = S^\dagger$ is a given time-independent Hermitian operator, and

$$\langle S \rangle = \text{Tr}(\rho S) . \quad (17.157)$$

The value of ρ at time $t = 0$ is denoted by ρ_0 .

- a) Show that

$$\rho(t) = \frac{\varrho(t)}{\text{Tr}(\varrho(t))} , \quad (17.158)$$

where

$$\varrho(t) = e^{(-i\hbar^{-1}\mathcal{H} + \gamma S)t} \rho_0 e^{(i\hbar^{-1}\mathcal{H} + \gamma S)t} . \quad (17.159)$$

- b) Show that $\text{Tr}(\rho^2)$ is time independent, provided that ρ represents a pure state.
 c) Show that for an arbitrary time-independent observable A

$$\frac{d\langle A \rangle}{dt} = i\hbar^{-1} \langle [\mathcal{H}, A] \rangle + \gamma (\langle AS + SA \rangle - 2\langle S \rangle \langle A \rangle) . \quad (17.160)$$

Note that Eq. (17.160) yields for the case $A = S$

$$\frac{d\langle S \rangle}{dt} = i\hbar^{-1} \langle [\mathcal{H}, S] \rangle + 2\gamma \langle (S - \langle S \rangle)^2 \rangle . \quad (17.161)$$

- d) As an example, consider a spin 1/2 particle. The 2×2 density matrix ρ is expressed as

$$\rho = \frac{1 + \mathbf{k} \cdot \boldsymbol{\sigma}}{2} , \quad (17.162)$$

where $\mathbf{k} = (k_x, k_y, k_z)$ is a real vector, and $\boldsymbol{\sigma} = (\sigma_x, \sigma_y, \sigma_z)$ is the Pauli matrix vector [see Eq. (6.137)]. The Hamiltonian \mathcal{H} and the operator S are expressed as

$$\hbar^{-1}\mathcal{H} = \boldsymbol{\omega} \cdot \boldsymbol{\sigma} , \quad (17.163)$$

$$S = \mathbf{s} \cdot \boldsymbol{\sigma} , \quad (17.164)$$

where $\boldsymbol{\omega} = (\omega_x, \omega_y, \omega_z)$ and $\mathbf{s} = (s_x, s_y, s_z)$ are real vectors. Show that

$$\frac{d\mathbf{k}}{dt} = 2\boldsymbol{\omega} \times \mathbf{k} + 2\gamma(\mathbf{s} - (\mathbf{s} \cdot \mathbf{k})\mathbf{k}) . \quad (17.165)$$

Note that for the case where $|\mathbf{k}| = 1$ (i.e. $\mathbf{k} \cdot \mathbf{k} = 1$) the following holds

$$(\mathbf{s} - (\mathbf{s} \cdot \mathbf{k}) \mathbf{k}) \cdot \mathbf{k} = 0, \quad (17.166)$$

and [recall that $\mathbf{A} \times (\mathbf{B} \times \mathbf{C}) = (\mathbf{A} \cdot \mathbf{C}) \mathbf{B} - (\mathbf{A} \cdot \mathbf{B}) \mathbf{C}$]

$$\mathbf{s} - (\mathbf{s} \cdot \mathbf{k}) \mathbf{k} = \mathbf{k} \times (\mathbf{s} \times \mathbf{k}),$$

and thus for this case Eq. (17.165) yields

$$\frac{d\mathbf{k}}{dt} = 2(\boldsymbol{\omega} + \gamma(\mathbf{k} \times \mathbf{s})) \times \mathbf{k}. \quad (17.167)$$

- e) Consider the case where $\omega_x = \omega_y = 0$. Find steady state solutions for Eq. (17.165).
 f) Consider the case where $\boldsymbol{\omega} = 0$ and $|\mathbf{s}| = 1$. For this Eq. (17.165) becomes

$$\frac{d\mathbf{k}}{dt} = 2\gamma(\hat{\mathbf{s}} - (\hat{\mathbf{s}} \cdot \mathbf{k}) \mathbf{k}). \quad (17.168)$$

where $\hat{\mathbf{s}}$ is a unit vector. Show that the solution of Eq. (17.168) is given by

$$\mathbf{k}(t) = \frac{\mathbf{k}_0 + \hat{\mathbf{s}}(\sinh(2\gamma t) + (\hat{\mathbf{s}} \cdot \mathbf{k}_0)(\cosh(2\gamma t) - 1))}{\cosh(2\gamma t) + (\hat{\mathbf{s}} \cdot \mathbf{k}_0) \sinh(2\gamma t)}, \quad (17.169)$$

where $\mathbf{k}_0 = \mathbf{k}(t=0)$.

12. **Grabert master equation** - Consider a given quantum system whose master equation, which governs the time evolution of the reduced density operator ρ , is given by

$$\frac{d\rho}{dt} = \Theta(\rho) = \Theta_u(\rho) - \Theta_d(\rho). \quad (17.170)$$

The first term, which is given by $\Theta_u(\rho) = (i/\hbar)[\rho, \mathcal{H}]$, where $\mathcal{H} = \mathcal{H}^\dagger$ is the time-independent Hamiltonian of the closed system, represents unitary evolution [compare with Eq. (8.29)]. The second term $\Theta_d(\rho) = \Theta_A(\rho) + \Theta_B(\rho)$ represents the effect of coupling between the closed system and its environment. The term $\Theta_A(\rho)$, which is given by $\Theta_A(\rho) = \gamma_E [Q, [Q, \rho]]$, is linear in ρ , whereas $\Theta_B(\rho)$, which is given by $\Theta_B(\rho) = \beta\gamma_E [Q, [Q, \mathcal{H}]_\rho]$ is nonlinear. The constant $\gamma_E > 0$ is a damping rate, the Hermitian operator $Q^\dagger = Q$ describes the interaction between the quantum system and its environment, and for a general operator A

$$A_\rho = \int_0^1 dq \rho^q A \rho^{1-q}. \quad (17.171)$$

- a) Show that Eq. (17.170) has a fixed point given by the Boltzmann distribution [compare with Eq. (8.40)]

$$\rho_0 = \frac{e^{-\beta\mathcal{H}}}{\text{Tr}(e^{-\beta\mathcal{H}})} , \quad (17.172)$$

where $\beta = 1/(k_{\text{B}}T)$ is the inverse of the thermal energy.

- b) Show that the damping term $\Theta_{\text{d}}(\rho)$ can be expressed as

$$\Theta_{\text{d}}(\rho) = \beta\gamma_{\text{E}} \left[Q, [Q, \mathcal{U}_{\text{H}}]_{\rho} \right] , \quad (17.173)$$

where \mathcal{U}_{H} , which is given by

$$\mathcal{U}_{\text{H}} = \mathcal{H} + \beta^{-1} \log \rho , \quad (17.174)$$

is the Helmholtz free energy operator.

- c) Show that

$$\text{Tr}(A_{\rho}B) = \text{Tr}(B_{\rho}A) , \quad (17.175)$$

for general operators A and B .

- d) Show that

$$\text{Tr}(A_{\rho}A) \geq 0 , \quad (17.176)$$

for a general Hermitian operator $A = A^{\dagger}$.

- e) Show that

$$\langle A \rangle = \text{Tr}(A\rho) = \text{Tr}(A_{\rho}) . \quad (17.177)$$

- f) Show that the time evolution of the Helmholtz free energy $\langle \mathcal{U}_{\text{H}} \rangle = \text{Tr}(\mathcal{U}_{\text{H}}\rho)$ is governed by

$$\frac{d\langle \mathcal{U}_{\text{H}} \rangle}{dt} = -\beta\gamma_{\text{E}} \text{Tr}(\mathcal{C}_{\rho}\mathcal{C}) , \quad (17.178)$$

where

$$\mathcal{C} = i[Q, \mathcal{U}_{\text{H}}] . \quad (17.179)$$

- g) Show that $d\langle \mathcal{U}_{\text{H}} \rangle/dt \leq 0$, i.e. the Helmholtz free energy $\langle \mathcal{U}_{\text{H}} \rangle$ is a monotonically decreasing function of time.

13. **The Unruh-Davies Effect** - The correlation function $C(\mathbf{r}', t')$ is defined by

$$C(\mathbf{r}', t') = \langle \mathbf{A}(\mathbf{r}, t) \cdot \mathbf{A}(\mathbf{r} + \mathbf{r}', t + t') \rangle , \quad (17.180)$$

where $\mathbf{A}(\mathbf{r}, t)$ is the electromagnetic vector potential given by Eq. (14.73). The electromagnetic field is assumed to be in thermal equilibrium at temperature T .

- a) Calculate $C(\mathbf{r}' = 0, t')$ at temperature T .
 b) Calculate $C(\mathbf{r}', t')$ at temperature $T = 0$.
 c) Consider an observer moving along a straight line (which is taken to be the x axis) with a constant proper acceleration a . The proper acceleration is defined as the acceleration in an inertial frame, comoving with the observer, in which he/she is instantaneously at rest. According to the theory of special relativity the position x of the observer, as being measured in a fixed inertial frame (for which both position and velocity vanish at $\tau = 0$), can be expressed in terms of the proper time τ as

$$x(\tau) = \frac{c^2}{a} \left(\cosh \frac{a\tau}{c} - 1 \right). \quad (17.181)$$

The proper time τ is the time as being measured by a clock comoving with the observer, and it is related to the time t in the fixed inertial frame by

$$t = \frac{c}{a} \sinh \frac{a\tau}{c}. \quad (17.182)$$

Consider the case where the observer is moving in an electromagnetic field at temperature $T = 0$. Show that the effective temperature of the electromagnetic field as being measured by the accelerated observer is given by

$$T_{\text{UD}} = \frac{\hbar a}{2\pi k_{\text{B}} c}. \quad (17.183)$$

14. **Driven two spin 1/2** - The Hamiltonian of a two spin 1/2 is given by $\mathcal{H} = \mathcal{H}_0 + \mathcal{H}_p$. The static part \mathcal{H}_0 is given by

$$\frac{\mathcal{H}_0}{\hbar} = -\frac{\omega_0 S_z}{2} + \omega_0 \vartheta \frac{S_y^2 - S_x^2}{8}, \quad (17.184)$$

where ω_0 and ϑ are real constants. The matrix representation of the vector operator $\mathbf{S} = \mathbf{S}_a + \mathbf{S}_b = (S_x, S_y, S_z)$, which represents the total angular momentum vector in units of $\hbar/2$, is given by (the first and second spins are labelled by the letters a and b, respectively)

$$\begin{aligned} S_x &= S_{ax} + S_{bx} \\ &= \begin{pmatrix} 0 & 0 & 1 & 0 \\ 0 & 0 & 0 & 1 \\ 1 & 0 & 0 & 0 \\ 0 & 1 & 0 & 0 \end{pmatrix} + \begin{pmatrix} 0 & 1 & 0 & 0 \\ 1 & 0 & 0 & 0 \\ 0 & 0 & 0 & 1 \\ 0 & 0 & 1 & 0 \end{pmatrix} \\ &= \begin{pmatrix} 0 & 1 & 1 & 0 \\ 1 & 0 & 0 & 1 \\ 1 & 0 & 0 & 1 \\ 0 & 1 & 1 & 0 \end{pmatrix}, \end{aligned} \quad (17.185)$$

$$\begin{aligned}
 S_y &= S_{ay} + S_{by} \\
 &\doteq \begin{pmatrix} 0 & 0 & -i & 0 \\ 0 & 0 & 0 & -i \\ i & 0 & 0 & 0 \\ 0 & i & 0 & 0 \end{pmatrix} + \begin{pmatrix} 0 & -i & 0 & 0 \\ i & 0 & 0 & 0 \\ 0 & 0 & 0 & -i \\ 0 & 0 & i & 0 \end{pmatrix} \\
 &= \begin{pmatrix} 0 & -i & -i & 0 \\ i & 0 & 0 & -i \\ i & 0 & 0 & -i \\ 0 & i & i & 0 \end{pmatrix},
 \end{aligned} \tag{17.186}$$

and

$$\begin{aligned}
 S_z &= S_{az} + S_{bz} \\
 &\doteq \begin{pmatrix} 1 & 0 & 0 & 0 \\ 0 & 1 & 0 & 0 \\ 0 & 0 & -1 & 0 \\ 0 & 0 & 0 & -1 \end{pmatrix} + \begin{pmatrix} 1 & 0 & 0 & 0 \\ 0 & -1 & 0 & 0 \\ 0 & 0 & 1 & 0 \\ 0 & 0 & 0 & -1 \end{pmatrix} \\
 &= \begin{pmatrix} 2 & 0 & 0 & 0 \\ 0 & 0 & 0 & 0 \\ 0 & 0 & 0 & 0 \\ 0 & 0 & 0 & -2 \end{pmatrix}.
 \end{aligned} \tag{17.187}$$

Note that

$$[S_i, S_j] = 2i\epsilon_{ijk}S_k. \tag{17.188}$$

The driving term \mathcal{H}_p of the Hamiltonian is given by

$$\begin{aligned}
 \frac{\mathcal{H}_p}{\hbar} &= \frac{\omega_{T1} (\cos(\omega_T t) S_x - \sin(\omega_T t) S_y)}{2} \\
 &\quad + \frac{\omega_{L1} \cos(\omega_L t + \theta) S_z}{2},
 \end{aligned} \tag{17.189}$$

where the transverse (longitudinal) driving amplitude ω_{T1} (ω_{L1}) and angular frequency ω_T (ω_L), and the phase shift θ , are all real constants.

a) For the case $\mathcal{H}_p = 0$ (no driving), show that

$$\frac{d\langle S_x \rangle}{dt} = \omega_0 \langle S_y \rangle + \frac{\omega_0 \vartheta}{4} \langle S_y S_z + S_z S_y \rangle, \tag{17.190}$$

$$\frac{d\langle S_y \rangle}{dt} = -\omega_0 \langle S_x \rangle + \frac{\omega_0 \vartheta}{4} \langle S_z S_x + S_x S_z \rangle, \tag{17.191}$$

and

$$\frac{d\langle S_z \rangle}{dt} = -\frac{\omega_0 \vartheta \langle S_x S_y + S_y S_x \rangle}{2}. \quad (17.192)$$

b) Show that

$$\begin{aligned} u_J &= \exp\left(\frac{J(e^{-2i\phi} S_-^2 - e^{2i\phi} S_+^2)}{8}\right) \\ &\doteq \exp\begin{pmatrix} 0 & 0 & 0 & -Je^{2i\phi} \\ 0 & 0 & 0 & 0 \\ 0 & 0 & 0 & 0 \\ Je^{-2i\phi} & 0 & 0 & 0 \end{pmatrix} \\ &= \begin{pmatrix} \cos J & 0 & 0 & -e^{2i\phi} \sin J \\ 0 & 1 & 0 & 0 \\ 0 & 0 & 1 & 0 \\ e^{-2i\phi} \sin J & 0 & 0 & \cos J \end{pmatrix}, \end{aligned} \quad (17.193)$$

where $S_{\pm} = S_x \pm iS_y$, and both J and ϕ are real. Employ the above relation (17.193) to show that for the case $\phi = 0$, the following holds

$$u_J^\dagger \begin{pmatrix} \cos(2J) & 0 & 0 & \sin(2J) \\ 0 & 0 & 0 & 0 \\ 0 & 0 & 0 & 0 \\ \sin(2J) & 0 & 0 & -\cos(2J) \end{pmatrix} u_J = \begin{pmatrix} 1 & 0 & 0 & 0 \\ 0 & 0 & 0 & 0 \\ 0 & 0 & 0 & 0 \\ 0 & 0 & 0 & -1 \end{pmatrix}. \quad (17.194)$$

c) Use Eq. (17.194) to show that the static part of the Hamiltonian \mathcal{H}_0 can be diagonalized by a transformation having the form

$$\begin{aligned} \frac{\mathcal{H}'_0}{\hbar} &= u_J^\dagger \frac{\mathcal{H}_0}{\hbar} u_J \\ &\doteq \begin{pmatrix} -\omega_e & 0 & 0 & 0 \\ 0 & 0 & 0 & 0 \\ 0 & 0 & 0 & 0 \\ 0 & 0 & 0 & \omega_e \end{pmatrix}, \end{aligned} \quad (17.195)$$

where

$$\omega_e = \omega_0 \sqrt{1 + \frac{\vartheta^2}{4}}. \quad (17.196)$$

d) Apply the same unitary transformation (17.195), which diagonalizes the static part of the Hamiltonian \mathcal{H}_0 , to the driving term \mathcal{H}_p , and show that

$$\begin{aligned}
 \frac{\mathcal{H}'_p}{\hbar} &= u_J^\dagger \frac{\mathcal{H}_p}{\hbar} u_J \\
 &\doteq \omega_{L1} \begin{pmatrix} \cos(2J) & 0 & 0 & -\sin(2J) \\ 0 & 0 & 0 & 0 \\ 0 & 0 & 0 & 0 \\ -\sin(2J) & 0 & 0 & -\cos(2J) \end{pmatrix} \cos(\omega_L t + \theta) \\
 &+ \omega_{T1} e^{i\omega_T t} \begin{pmatrix} 0 & \frac{\sin J}{2} & \frac{\sin J}{2} & 0 \\ \frac{\cos J}{2} & 0 & 0 & -\frac{\sin J}{2} \\ \frac{\cos J}{2} & 0 & 0 & -\frac{\sin J}{2} \\ 0 & \frac{\cos J}{2} & \frac{\cos J}{2} & 0 \end{pmatrix} \\
 &+ \omega_{T1} e^{-i\omega_T t} \begin{pmatrix} 0 & \frac{\cos J}{2} & \frac{\cos J}{2} & 0 \\ \frac{\sin J}{2} & 0 & 0 & \frac{\cos J}{2} \\ \frac{\sin J}{2} & 0 & 0 & \frac{\cos J}{2} \\ 0 & -\frac{\sin J}{2} & -\frac{\sin J}{2} & 0 \end{pmatrix}, \tag{17.197}
 \end{aligned}$$

where

$$\tan(2J) = \frac{\vartheta}{2}. \tag{17.198}$$

- e) Apply to $\mathcal{H}' = \mathcal{H}'_0 + \mathcal{H}'_p$ a rotating frame transformation given by [see Eq. (6.177)]

$$\frac{\mathcal{H}''}{\hbar} = -iu_0^\dagger \frac{du_0}{dt} + u_0^\dagger \frac{\mathcal{H}'}{\hbar} u_0, \tag{17.199}$$

where [see Eq. (17.195)]

$$u_0 \doteq \begin{pmatrix} e^{-i\omega_T t} & 0 & 0 & 0 \\ 0 & 1 & 0 & 0 \\ 0 & 0 & 1 & 0 \\ 0 & 0 & 0 & e^{i\omega_T t} \end{pmatrix}. \tag{17.200}$$

Assume that $\omega_T \simeq -\omega_0$, $\omega_L \simeq 2\omega_0$ and $|\vartheta| \ll 1$. Show that in the rotating wave approximation (RWA), for which rapidly oscillating terms are disregarded, \mathcal{H}'' is replaced by $\mathcal{H}''_{\text{RWA}}$, which is given by

$$\begin{aligned}
 \frac{\mathcal{H}''_{\text{RWA}}}{\hbar} &= -\frac{\omega_{Td} S_z}{2} + \frac{\Omega_{T1} (S_+ + S_-)}{4} \\
 &- \frac{\Omega_{L1} e^{-i\omega_d t} S_+^2 + \Omega_{L1}^* e^{i\omega_d t} S_-^2}{16}, \tag{17.201}
 \end{aligned}$$

where

$$\Omega_{T1} = \omega_{T1} \cos(J) , \quad (17.202)$$

$$\Omega_{L1} = \omega_{L1} \sin(2J) e^{-i\theta} , \quad (17.203)$$

and where

$$\omega_{Td} = \omega_e + \omega_T , \quad (17.204)$$

$$\omega_d = \omega_L - 2\omega_T . \quad (17.205)$$

f) In the mean field approximation (MFA) it is assumed that

$$\langle O_a O_b \rangle = \langle O_a \rangle \langle O_b \rangle , \quad (17.206)$$

where O_a (O_b) is a given observable of spin a (b). Employ the RWA Hamiltonian (17.201) to show that the MFA yields the following coupled nonlinear equations of motion

$$\frac{d\langle S_{a+} \rangle}{dt} = -i\omega_{Td} \langle S_{a+} \rangle - i\Omega_{T1} \langle S_{az} \rangle + i \frac{\Omega_{L1}^* e^{i\omega_d t} \langle S_{az} \rangle \langle S_{b-} \rangle}{2} , \quad (17.207)$$

$$\frac{d\langle S_{a-} \rangle}{dt} = i\omega_{Td} \langle S_{a-} \rangle + i\Omega_{T1} \langle S_{az} \rangle - i \frac{\Omega_{L1} e^{-i\omega_d t} \langle S_{az} \rangle \langle S_{b+} \rangle}{2} , \quad (17.208)$$

$$\frac{d\langle S_{az} \rangle}{dt} = \Omega_{T1} \frac{\langle S_{a+} \rangle - \langle S_{a-} \rangle}{2i} - \frac{\Omega_{L1} e^{-i\omega_d t} \langle S_{a+} \rangle \langle S_{b+} \rangle - \Omega_{L1}^* e^{i\omega_d t} \langle S_{a-} \rangle \langle S_{b-} \rangle}{4i} , \quad (17.209)$$

$$\frac{d\langle S_{b+} \rangle}{dt} = -i\omega_{Td} \langle S_{b+} \rangle - i\Omega_{T1} \langle S_{bz} \rangle + i \frac{\Omega_{L1}^* e^{i\omega_d t} \langle S_{bz} \rangle \langle S_{a-} \rangle}{2} , \quad (17.210)$$

$$\frac{d\langle S_{b-} \rangle}{dt} = i\omega_{Td} \langle S_{b-} \rangle + i\Omega_{T1} \langle S_{bz} \rangle - i \frac{\Omega_{L1} e^{-i\omega_d t} \langle S_{bz} \rangle \langle S_{a+} \rangle}{2} , \quad (17.211)$$

$$\frac{d\langle S_{bz} \rangle}{dt} = \Omega_{T1} \frac{\langle S_{b+} \rangle - \langle S_{b-} \rangle}{2i} - \frac{\Omega_{L1} e^{-i\omega_d t} \langle S_{a+} \rangle \langle S_{b+} \rangle - \Omega_{L1}^* e^{i\omega_d t} \langle S_{a-} \rangle \langle S_{b-} \rangle}{4i} . \quad (17.212)$$

g) **Inverse transformation** - Show that for the case Ω_{T1} (no transverse driving) and ω_d (vanishing detuning frequency) the following holds

$$u_J \frac{\mathcal{H}_{\text{RWA}}''}{\hbar} u_J^\dagger = \begin{pmatrix} -2\mathcal{B} & 0 & 0 & -2\mathcal{J} \\ 0 & 0 & 0 & 0 \\ 0 & 0 & 0 & 0 \\ -2\mathcal{J}^* & 0 & 0 & 2\mathcal{B} \end{pmatrix}, \quad (17.213)$$

where (recall that $\Omega_{L1} = \omega_{L1} e^{-i\theta} \sin 2J$)

$$\mathcal{B} = \frac{\omega_{\text{Td}} \cos 2J}{2} - \frac{\omega_{L1} \zeta' \sin^2 2J}{4}, \quad (17.214)$$

$$\mathcal{J} = e^{2i\phi} \left(\frac{\omega_{\text{Td}} \sin 2J}{2} + \frac{\omega_{L1} (\zeta' \cos 2J - i\zeta'') \sin 2J}{4} \right), \quad (17.215)$$

$\zeta = e^{i(\theta+2\phi)} = \zeta' + i\zeta''$, and both ζ' and ζ'' are real.

15. **two-mode squeezing** - Consider a system whose Hamiltonian is given by

$$\mathcal{H} = \mathcal{H}_0 + \mathcal{H}_p, \quad (17.216)$$

where

$$\mathcal{H}_0 = \hbar\omega_0 \left[(1 + \eta) B_1^\dagger B_1 + (1 - \eta) B_2^\dagger B_2 \right], \quad (17.217)$$

$$\mathcal{H}_p = i\hbar\omega_0 \zeta(t) \left(e^{2i(\omega_0 t - \phi)} B_1 B_2 - e^{-2i(\omega_0 t - \phi)} B_1^\dagger B_2^\dagger \right), \quad (17.218)$$

the annihilation B_n and creation B_n^\dagger operators satisfy the following commutation relations

$$\left[B_{n'}, B_{n''}^\dagger \right] = \delta_{n', n''}, \quad (17.219)$$

$$\left[B_{n'}, B_{n''} \right] = \left[B_{n'}^\dagger, B_{n''}^\dagger \right] = 0, \quad (17.220)$$

where $n', n'' \in \{1, 2\}$, the real parameters ω_0 , η and ϕ are real, and $\zeta(t)$ is a real function of time t .

- a) Show that the time evolution of the state vector of the system $|\psi\rangle$ is given by

$$|\psi(t)\rangle = e^{-i\mathcal{H}_0 t/\hbar} S(\xi, \phi) |\psi(t=0)\rangle, \quad (17.221)$$

where the so-called two-mode squeezing operator $S(\xi, \phi)$ is given by

$$S(\xi, \phi) = \exp \left[\xi \left(e^{-2i\phi} B_1 B_2 - e^{2i\phi} B_1^\dagger B_2^\dagger \right) \right], \quad (17.222)$$

where

$$\xi = \omega_0 \int_0^t dt' \zeta(t'). \quad (17.223)$$

b) Show that

$$S^\dagger(\xi, \phi) B_1 S(\xi, \phi) = B_1 \cosh \xi - B_2^\dagger e^{2i\phi} \sinh \xi, \quad (17.224)$$

and

$$S^\dagger(\xi, \phi) B_2 S(\xi, \phi) = B_2 \cosh \xi - B_1^\dagger e^{2i\phi} \sinh \xi. \quad (17.225)$$

c) The state $|\xi, \phi\rangle$ is defined by

$$|\xi, \phi\rangle = S(\xi, \phi) |0, 0\rangle, \quad (17.226)$$

where $|0, 0\rangle$ is the ground state of \mathcal{H}_0 . Calculate $\Delta X_\theta \Delta P_\theta$ with respect to the state $|\xi, \phi\rangle$, where the operators X_θ and P_θ are defined by

$$X_\theta = X_1 \cos \theta + X_2 \sin \theta, \quad (17.227)$$

$$P_\theta = P_1 \cos \theta + P_2 \sin \theta, \quad (17.228)$$

θ is a real constant, the operators X_1, X_2, P_1 and P_2 are defined by

$$X_1 = A_1 + A_1^\dagger, \quad (17.229)$$

$$X_2 = A_2 + A_2^\dagger, \quad (17.230)$$

$$P_1 = i(A_1 - A_1^\dagger), \quad (17.231)$$

$$P_2 = i(A_2 - A_2^\dagger), \quad (17.232)$$

and

$$A_1 = \frac{B_1 + B_2}{\sqrt{2}}, \quad (17.233)$$

$$A_2 = \frac{B_1 - B_2}{\sqrt{2}}. \quad (17.234)$$

d) Show that the two-mode squeezing operator $S(\xi, \phi)$ can be factorized as

$$\begin{aligned} S(\xi, \phi) &= \exp\left(-e^{2i\phi} \tanh \xi B_1^\dagger B_2^\dagger\right) \\ &\quad \times \exp\left(-\log(\cosh \xi) (B_1 B_1^\dagger + B_2^\dagger B_2)\right) \\ &\quad \times \exp\left(e^{-2i\phi} \tanh \xi B_1 B_2\right). \end{aligned} \quad (17.235)$$

e) **Yurke-Potasek temperature** - Let O_1 be a single mode operator, which operates on the space of the first mode (corresponding to the operators B_1 and B_1^\dagger). Calculate the expectation value $\langle O_1 \rangle$ with respect to the state $e^{-i\mathcal{H}_0 t/\hbar} |\xi, \phi\rangle$, and show that the result is the

same as the expectation value that is obtained when the mode is assumed to be in thermal equilibrium at an effective temperature T_{eff} given by

$$T_{\text{eff}} = \frac{\hbar\omega_1}{2k_{\text{B}} \log(\coth \xi)}, \quad (17.236)$$

where $\omega_1 = \omega_0(1 + \eta)$ is the angular frequency of the first mode.

f) Show that

$$S(\xi, 0) = \exp \left[\frac{\xi (A_1^2 - A_1^{\dagger 2})}{2} \right] \exp \left[-\frac{\xi (A_2^2 - A_2^{\dagger 2})}{2} \right]. \quad (17.237)$$

g) Show that

$$S(\xi, 0) = \int_{-\infty}^{\infty} dX'_1 \int_{-\infty}^{\infty} dX'_2 |e^{-\xi X'_1}, e^{\xi X'_2}\rangle \langle X'_1, X'_2|, \quad (17.238)$$

where $|X'_1, X'_2\rangle$ denotes common eigenvectors of the operators X_1 and X_2 [see Eqs. (17.229) and (17.230)] with eigenvalues X'_1 and X'_2 respectively.

h) The normalized position operators X_+ and X_- are defined by [see Eqs. (17.233) and (17.234)]

$$X_{\pm} = \frac{X_1 \pm X_2}{\sqrt{2}}. \quad (17.239)$$

Calculate the joint probability distribution $P_{\text{x}}(X'_+, X'_-)$ to obtain the values X'_+ and X'_- in a measurement of X_+ and X_- , respectively, when the system is in the state $|\xi, 0\rangle$.

17.5 Solutions

1. In the absence of any externally applied driving force, i.e. when $F_{\text{ex}} = 0$, the classical equation of motion is given by (17.8)

$$m\ddot{x} + m\gamma\dot{x} + m\omega_0^2 x = f(t), \quad (17.240)$$

where $f(t)$ represents a random force acting on the resonator due to the coupling with the thermal bath at temperature T . Bellow we consider statistical properties of the fluctuating function $x(t)$. However, since some of the quantities we define may diverge, we consider a sampling of the function $x(t)$ in the finite time interval $(-\tau/2, \tau/2)$, namely

$$x_\tau(t) = \begin{cases} x(t) & -\tau/2 < t < \tau/2 \\ 0 & \text{else} \end{cases} . \quad (17.241)$$

The equipartition theorem requires that

$$\frac{1}{2}m\omega_0^2 \langle x^2 \rangle = \frac{1}{2}k_B T , \quad (17.242)$$

where

$$\langle x^2 \rangle \equiv \lim_{\tau \rightarrow \infty} \frac{1}{\tau} \int_{-\infty}^{+\infty} dt x_\tau^2(t) . \quad (17.243)$$

Introducing the Fourier transform (FT)

$$x_\tau(t) = \frac{1}{\sqrt{2\pi}} \int_{-\infty}^{\infty} d\omega x_\tau(\omega) e^{-i\omega t} , \quad (17.244)$$

one finds that

$$\begin{aligned} \langle x^2 \rangle &= \frac{1}{2\pi} \int_{-\infty}^{\infty} d\omega x_\tau(\omega) \int_{-\infty}^{\infty} d\omega' x_\tau(\omega') \\ &\quad \times \lim_{\tau \rightarrow \infty} \frac{1}{\tau} \underbrace{\int_{-\infty}^{+\infty} dt e^{-i(\omega+\omega')t}}_{2\pi\delta(\omega+\omega')} \\ &= \lim_{\tau \rightarrow \infty} \frac{1}{\tau} \int_{-\infty}^{\infty} d\omega x_\tau(\omega) x_\tau(-\omega) . \end{aligned} \quad (17.245)$$

Since $x(t)$ is real $x_\tau(-\omega) = x_\tau^*(\omega)$. In terms of the power spectrum $S_x(\omega)$, which is defined as

$$S_x(\omega) = \lim_{\tau \rightarrow \infty} \frac{1}{\tau} |x_\tau(\omega)|^2 , \quad (17.246)$$

one has

$$\langle x^2 \rangle = \int_{-\infty}^{\infty} d\omega S_x(\omega) . \quad (17.247)$$

Next, we take the FT of Eq. (17.240)

$$(-m\omega^2 - im\omega\gamma + m\omega_0^2) x(\omega) = f(\omega) , \quad (17.248)$$

where

$$f(t) = \frac{1}{\sqrt{2\pi}} \int_{-\infty}^{\infty} d\omega f(\omega) e^{-i\omega t} . \quad (17.249)$$

Taking the absolute value squared yields

$$S_x(\omega) = \frac{S_f(\omega)}{m^2 [(\omega\gamma)^2 + (\omega_0^2 - \omega^2)^2]} . \quad (17.250)$$

Integrating Eq. (17.250) leads to

$$\int_{-\infty}^{\infty} d\omega S_x(\omega) = \frac{1}{m^2} \int_{-\infty}^{\infty} d\omega \frac{S_f(\omega)}{(\omega\gamma)^2 + (\omega_0^2 - \omega^2)^2} . \quad (17.251)$$

Assuming that in the vicinity of ω_0 , i.e. near the peak of the integrand, the spectral density $S_f(\omega)$ is a smooth function on the scale of the width of the peak γ , and also assuming that $\omega_0 \gg \gamma$, one approximately finds that

$$\begin{aligned} \int_{-\infty}^{\infty} d\omega S_x(\omega) &\simeq S_f(\omega_0) \frac{1}{m^2} \int_{-\infty}^{\infty} \frac{d\omega}{(\omega\gamma)^2 + (\omega_0^2 - \omega^2)^2} \\ &= \frac{S_f(\omega_0)}{m^2 \omega_0^3} \int_{-\infty}^{\infty} \frac{d\alpha}{(\alpha\gamma/\omega_0)^2 + (1 - \alpha^2)^2} \\ &\simeq \frac{S_f(\omega_0)}{m^2 \omega_0^3} \underbrace{\int_{-\infty}^{\infty} \frac{d\alpha}{(\alpha\gamma/\omega_0)^2 + 1}}_{\pi\omega_0/\gamma} \\ &= \frac{\pi}{m^2 \gamma \omega_0^2} S_f(\omega_0) . \end{aligned} \quad (17.252)$$

This together with Eqs. (17.242) and (17.247) yields

$$S_f(\omega_0) = \frac{m\gamma k_B T}{\pi} , \quad (17.253)$$

thus Eq. (17.250) becomes

$$S_x(\omega) = \frac{\gamma k_B T}{m\pi} \frac{1}{(\omega\gamma)^2 + (\omega_0^2 - \omega^2)^2} . \quad (17.254)$$

At the peak $\omega = \omega_0$ one finds

$$S_x(\omega_0) = \frac{k_B T}{m\pi\gamma\omega_0^2} . \quad (17.255)$$

The correlation function $C(t')$ of the fluctuating force f is defined as:

$$C(t') = \langle f(t) f(t+t') \rangle \equiv \lim_{\tau \rightarrow \infty} \frac{1}{\tau} \int_{-\infty}^{+\infty} dt f(t) f(t+t') . \quad (17.256)$$

Using Eq. (17.249) one finds

$$\begin{aligned}
C(t') &= \frac{1}{2\pi} \lim_{\tau \rightarrow \infty} \frac{1}{\tau} \int_{-\infty}^{+\infty} dt \int_{-\infty}^{\infty} d\omega f(\omega) e^{-i\omega t} \\
&\quad \times \int_{-\infty}^{\infty} d\omega' f(\omega') e^{-i\omega'(t+t')} \\
&= \frac{1}{2\pi} \lim_{\tau \rightarrow \infty} \frac{1}{\tau} \int_{-\infty}^{\infty} d\omega e^{-i\omega t'} f(\omega) \\
&\quad \times \int_{-\infty}^{\infty} d\omega' f(\omega') \underbrace{\int_{-\infty}^{+\infty} dt e^{-i(\omega+\omega')t}}_{2\pi\delta(\omega+\omega')} \\
&= \lim_{\tau \rightarrow \infty} \frac{1}{\tau} \int_{-\infty}^{\infty} d\omega e^{-i\omega t'} f(\omega) f(-\omega) \\
&= \int_{-\infty}^{\infty} d\omega e^{-i\omega t'} S_f(\omega) .
\end{aligned} \tag{17.257}$$

Using Eq. (17.253) and assuming as before that $S_f(\omega)$ is smooth function near $\omega = \omega_0$ allow determining the coefficient $C(t')$

$$C(t') = \frac{m\gamma k_B T}{\pi} \underbrace{\int_{-\infty}^{\infty} d\omega e^{-i\omega t'}}_{2\pi\delta(t')} = 2m\gamma k_B T \delta(t') . \tag{17.258}$$

2. Using the definition (17.39) and Eqs. (17.57), (17.59) and (17.60) one has

$$\begin{aligned}
\langle f(t) f(t+t') \rangle &= -\frac{m\hbar\omega_0}{2} \\
&\quad \times \langle [F^\dagger(t) - F(t)] [F^\dagger(t+t') - F(t+t')] \rangle \\
&= m\hbar\gamma\omega_0 (2\hat{n}_0 + 1) \delta(t') \\
&= m\hbar\gamma\omega_0 \frac{e^{\beta\hbar\omega_0} + 1}{e^{\beta\hbar\omega_0} - 1} \delta(t') \\
&= m\hbar\gamma\omega_0 \coth\left(\frac{\beta\hbar\omega_0}{2}\right) \delta(t') .
\end{aligned} \tag{17.259}$$

In the classical limit where $k_B T \gg \hbar\omega_0$ one finds that

$$\langle f(t) f(t+t') \rangle = 2m\gamma k_B T \delta(t') , \tag{17.260}$$

in agreement with Eq. (17.258).

3. With the help of Eqs. (5.11), (17.64) and (17.65) the autocorrelation function can be expressed in terms of the noise operator $F(t')$ [see Eq. (17.36)], which satisfy the correlation relations (17.57), (17.59) and (17.60)

$$\begin{aligned}
 g(\tau) &= \text{Re} \langle x(t) x(t + \tau) \rangle \\
 &= \frac{\hbar}{2m\omega} \text{Re} \langle (a(t) + a^\dagger(t)) (a(t + \tau) + a^\dagger(t + \tau)) \rangle \\
 &= \frac{\hbar}{2m\omega} \text{Re} \langle a(t) a^\dagger(t + \tau) + a^\dagger(t) a(t + \tau) \rangle \\
 &= \frac{\hbar}{2m\omega} \text{Re} \int_{t_0}^t dt' \int_{t_0}^t dt'' e^{i\omega_0 + \gamma}(t' - t) e^{(-i\omega_0 + \gamma)(t'' - t - \tau)} \langle F(t') F^\dagger(t'') \rangle \\
 &\quad + \frac{\hbar}{2m\omega} \text{Re} \int_{t_0}^t dt' \int_{t_0}^t dt'' e^{(-i\omega_0 + \gamma)(t' - t)} e^{i\omega_0 + \gamma}(t'' - t - \tau) \langle F^\dagger(t') F(t'') \rangle . \\
 &= \frac{\hbar\gamma(\hat{n}_0 + 1)}{m\omega} \text{Re} \int_{t_0}^t dt' e^{(i\omega_0 + \gamma)(t' - t)} e^{(-i\omega_0 + \gamma)(t' - t - \tau)} \\
 &\quad + \frac{\hbar\gamma\hat{n}_0}{m\omega} \text{Re} \int_{t_0}^t dt' e^{(-i\omega_0 + \gamma)(t' - t)} e^{i\omega_0 + \gamma}(t' - t - \tau) ,
 \end{aligned} \tag{17.261}$$

where [see Eq. (17.58)]

$$\hat{n}_0 = \frac{1}{e^{\beta\hbar\omega_0} - 1} , \tag{17.262}$$

thus

$$\begin{aligned}
 g(\tau) &= \frac{\hbar(2\hat{n}_0 + 1)}{m\omega} \cos(\omega_0\tau) e^{-\gamma\tau} \frac{1 - e^{-2\gamma(t-t_0)}}{2} \\
 &= \frac{\hbar \coth \frac{\beta\hbar\omega}{2}}{m\omega} \cos(\omega_0\tau) e^{-\gamma\tau} \frac{1 - e^{-2\gamma(t-t_0)}}{2} .
 \end{aligned} \tag{17.263}$$

In steady state, i.e. for $\gamma(t - t_0) \gg 1$, the autocorrelation function $g(\tau)$ becomes

$$g(\tau) = \frac{\hbar}{2m\omega} \coth \frac{\beta\hbar\omega}{2} \cos(\omega_0\tau) e^{-\gamma\tau} . \tag{17.264}$$

4. The Bloch equation (17.130) for this case becomes

$$\dot{P}_z = -\Gamma_T P_z - \frac{P_z - P_{z0}}{T_1} , \tag{17.265}$$

thus in steady state

$$P_z = \frac{P_{z0}}{1 + \Gamma_T T_1} . \tag{17.266}$$

Clearly, by symmetry, $P_x = P_y = 0$ in steady state.

5. Substituting Eq. (17.142) into the Schrödinger equation

$$i \frac{d}{dt} |\Psi\rangle = \hbar^{-1} \mathcal{H} |\Psi\rangle, \quad (17.267)$$

and multiplying from the left by $\langle \omega |$ yields [note that $\langle \omega | \omega' \rangle = \delta(\omega' - \omega)$]

$$i \dot{b}_\omega e^{-i\omega t} = \frac{\gamma_1^{1/2} a_1 + \gamma_2^{1/2} a_2}{\sqrt{2\pi}}. \quad (17.268)$$

The solution is given by

$$b_\omega(t) = b_\omega(0) - i \int_0^t dt' e^{i\omega t'} \frac{\gamma_1^{1/2} a_1(t') + \gamma_2^{1/2} a_2(t')}{\sqrt{2\pi}}. \quad (17.269)$$

Multiplying the Schrödinger equation (17.267) from the left by $\langle \varphi_{1,2} |$ yields

$$i \dot{a}_1 = \omega_1 a_1 + \eta a_2 + \frac{\gamma_1^{*1/2}}{\sqrt{2\pi}} \int_{-\infty}^{\infty} d\omega'' b_{\omega''} e^{-i\omega'' t}, \quad (17.270)$$

$$i \dot{a}_2 = \omega_2 a_2 + \eta^* a_1 + \frac{\gamma_2^{*1/2}}{\sqrt{2\pi}} \int_{-\infty}^{\infty} d\omega'' b_{\omega''} e^{-i\omega'' t}. \quad (17.271)$$

With the help of Eq. (17.269) and the identity

$$\int_{-\infty}^{\infty} d\omega e^{i\omega(t'-t)} = 2\pi \delta(t' - t), \quad (17.272)$$

one obtains

$$\frac{d}{dt} \begin{pmatrix} a_1 \\ a_2 \end{pmatrix} + iM \begin{pmatrix} a_1 \\ a_2 \end{pmatrix} = \begin{pmatrix} F_1 \\ F_2 \end{pmatrix}, \quad (17.273)$$

where the matrix M is given by

$$M = \begin{pmatrix} \omega_1 - i|\gamma_1| & \eta - i\sqrt{\gamma_1^* \gamma_2} \\ \eta^* - i\sqrt{\gamma_1 \gamma_2^*} & \omega_2 - i|\gamma_2| \end{pmatrix}, \quad (17.274)$$

and where the fluctuating terms F_1 and F_2 are given by

$$F_1 = -i \frac{\gamma_1^{*1/2}}{\sqrt{2\pi}} \int_{-\infty}^{\infty} d\omega'' b_{\omega''}(0) e^{-i\omega'' t}, \quad (17.275)$$

$$F_2 = -i \frac{\gamma_2^{*1/2}}{\sqrt{2\pi}} \int_{-\infty}^{\infty} d\omega'' b_{\omega''}(0) e^{-i\omega'' t}. \quad (17.276)$$

When γ_1 , γ_2 and η are all real the eigenvalues ω_{\pm} of the matrix M are given by

$$\omega_{\pm} = \omega_p - i\gamma_p \pm \omega_m \sqrt{1 - \left(\frac{\sqrt{\gamma_1 \gamma_2} + i\eta}{\omega_m} \right)^2 - \left(2i + \frac{\gamma_m}{\omega_m} \right) \frac{\gamma_m}{\omega_m}}, \quad (17.277)$$

where

$$\omega_p = \frac{\omega_1 + \omega_2}{2}, \quad (17.278)$$

$$\omega_m = \frac{\omega_2 - \omega_1}{2}, \quad (17.279)$$

$$\gamma_p = \frac{\gamma_1 + \gamma_2}{2}, \quad (17.280)$$

$$\gamma_m = \frac{\gamma_2 - \gamma_1}{2}. \quad (17.281)$$

The real (imaginary) part of ω_{\pm} represents the angular frequency (damping rate) of the eigenstates.

6. The Hamiltonian of the closed system is given by

$$\mathcal{H}_q \doteq \frac{\hbar}{2} \Omega(t) \cdot \boldsymbol{\sigma}, \quad (17.282)$$

where

$$\Omega(t) = \omega_0 \hat{\mathbf{z}} + \omega_1 (\cos(\omega t) \hat{\mathbf{x}} + \sin(\omega t) \hat{\mathbf{y}}), \quad (17.283)$$

and where [see Eq. (4.22)]

$$\omega_0 = \frac{|e| B_0}{m_e c}, \quad (17.284)$$

$$\omega_1 = \frac{|e| B_1}{m_e c}. \quad (17.285)$$

In terms of the vectors $\hat{\mathbf{u}}_{\pm} = (1/2)(\hat{\mathbf{x}} \pm i\hat{\mathbf{y}})$ the vector $\Omega(t)$ is given by

$$\Omega(t) = \omega_0 \hat{\mathbf{z}} + \omega_1 (e^{-i\omega t} \hat{\mathbf{u}}_+ + e^{i\omega t} \hat{\mathbf{u}}_-). \quad (17.286)$$

In terms of T_1 , T_2 and P_{z0} Eqs. (17.119) and (17.120) become

$$\dot{P}_z = (\Omega(t) \times \mathbf{P})_z - \frac{P_z - P_{z0}}{T_1}, \quad (17.287)$$

and

$$\dot{P}_+ = (\Omega(t) \times \mathbf{P})_+ - \frac{P_+}{T_2}. \quad (17.288)$$

With the help of the identities

$$\hat{\mathbf{z}} \times \hat{\mathbf{u}}_{\pm} = \mp i \hat{\mathbf{u}}_{\pm}, \quad (17.289)$$

$$\hat{\mathbf{u}}_+ \times \hat{\mathbf{u}}_+ = \hat{\mathbf{u}}_- \times \hat{\mathbf{u}}_- = 0, \quad (17.290)$$

$$\hat{\mathbf{u}}_+ \times \hat{\mathbf{u}}_- = -i(1/2) \hat{\mathbf{z}}, \quad (17.291)$$

Eqs. (17.287) and (17.288) become

$$\dot{P}_z = \frac{i\omega_1 (e^{i\omega t} P_+ - e^{-i\omega t} P_-)}{2} - \frac{P_z - P_{z0}}{T_1}, \quad (17.292)$$

and

$$\dot{P}_+ = -i\omega_0 P_+ + i\omega_1 e^{-i\omega t} P_z - \frac{P_+}{T_2}. \quad (17.293)$$

By employing the transformation into the rotating frame [see for comparison Eq. (6.375)]

$$P_+(t) = e^{-i\omega t} P_{R+}(t), \quad (17.294)$$

$$P_-(t) = e^{i\omega t} P_{R-}(t), \quad (17.295)$$

Eqs. (17.292) and (17.293) become

$$\dot{P}_z = \frac{i\omega_1 (P_{R+} - P_{R-})}{2} - \frac{P_z - P_{z0}}{T_1}, \quad (17.296)$$

and

$$\dot{P}_{R+} = i(\omega - \omega_0) P_{R+} + i\omega_1 P_z - \frac{P_{R+}}{T_2}. \quad (17.297)$$

a) In steady state, i.e. when $\dot{P}_z = \dot{P}_{R+} = 0$, one has

$$\frac{i\omega_1 (P_{R+} - P_{R-})}{2} = \frac{P_z - P_{z0}}{T_1}, \quad (17.298)$$

$$i(\omega - \omega_0) P_{R+} + i\omega_1 P_z = \frac{P_{R+}}{T_2}, \quad (17.299)$$

thus (recall that $P_{R+} = P_{R-}^*$)

$$P_z = \frac{1 + T_2^2 (\omega - \omega_0)^2}{1 + T_2^2 (\omega - \omega_0)^2 + \omega_1^2 T_1 T_2} P_{z0}. \quad (17.300)$$

b) In steady state one has

$$P_{R+} = \frac{iT_2\omega_1 [1 + iT_2(\omega - \omega_0)]}{1 + T_2^2 (\omega - \omega_0)^2 + \omega_1^2 T_1 T_2} P_{z0}, \quad (17.301)$$

thus

$$P_+ = \frac{iT_2\omega_1 [1 + iT_2(\omega - \omega_0)]}{1 + T_2^2 (\omega - \omega_0)^2 + \omega_1^2 T_1 T_2} P_{z0} e^{-i\omega t}. \quad (17.302)$$

Using the relations

$$\begin{aligned} P_x &= 2\omega_1 [\cos(\omega t) \chi'(\omega) + \sin(\omega t) \chi''(\omega)] \\ &= \omega_1 (e^{-i\omega t} \chi(\omega) + e^{i\omega t} \chi^*(\omega)), \end{aligned} \quad (17.303)$$

and

$$P_x = P_+ + P_- , \quad (17.304)$$

one finds that

$$\chi(\omega) = \frac{iT_2 [1 + iT_2(\omega - \omega_0)]}{1 + T_2^2(\omega - \omega_0)^2 + \omega_1^2 T_1 T_2} P_{z0} . \quad (17.305)$$

7. For the case where $v = 0$ the steady state solution (i.e. the solution for the case where $\dot{\mathcal{P}} = 0$) can be expressed as [see Eqs. (17.300) and (17.301)]

$$\mathcal{P}_S = \begin{pmatrix} \frac{iT_2\omega_1(1+iT_2\Delta)P_{z0}}{1+T_2^2\Delta^2+\omega_1^2T_1T_2} \\ \frac{-iT_2\omega_1(1-iT_2\Delta)P_{z0}}{1+T_2^2\Delta^2+\omega_1^2T_1T_2} \\ \frac{(1+T_2^2\Delta^2)P_{z0}}{1+T_2^2\Delta^2+\omega_1^2T_1T_2} \end{pmatrix} . \quad (17.306)$$

Consider a solution having the form $\mathcal{P} = \mathcal{P}_S + p_+ e^{i\delta t} + p_- e^{-i\delta t}$. Substituting into Eq. (17.148) yields a steady state solution given by

$$p_+ = (-M + i\delta)^{-1} \begin{pmatrix} v \\ 0 \\ 0 \end{pmatrix} , \quad (17.307)$$

$$p_- = (-M - i\delta)^{-1} \begin{pmatrix} 0 \\ v^* \\ 0 \end{pmatrix} , \quad (17.308)$$

and thus [see Eq. (17.147)]

$$P_z = \frac{(1 + T_2^2 \Delta^2) P_{z0}}{1 + T_2^2 \Delta^2 + \omega_1^2 T_1 T_2} - \text{Im} \left(\omega_1 \left(\frac{1}{T_2} + i\Delta + i\delta \right) \mathcal{D}^{-1} v e^{i\delta t} \right) , \quad (17.309)$$

where

$$\mathcal{D} = i\delta \left(\Delta^2 - \delta^2 + \omega_1^2 + \frac{2}{T_1 T_2} + \frac{1}{T_2^2} \right) + \frac{\Delta^2 - \delta^2}{T_1} + \frac{\omega_1^2 - 2\delta^2}{T_2} + \frac{1}{T_1 T_2} . \quad (17.310)$$

As can be seen from Eq. (17.310), when both T_1^{-1} and T_2^{-1} are small, $|\mathcal{D}|$ obtains a relatively small value when $\delta \simeq 0$ and when $\delta \simeq \pm\omega_R$, where $\omega_R = \sqrt{\omega_1^2 + \Delta^2}$ is the Rabi frequency [see Eq. (6.383)].

8. When coupling to an environment is disregarded Eqs. (17.82) and (17.83) become

$$\frac{d\sigma_z}{dt} = \frac{1}{i\hbar} [\sigma_z, \mathcal{H}_q] , \quad (17.311)$$

and

$$\frac{d\sigma_+}{dt} = \frac{1}{i\hbar} [\sigma_+, \mathcal{H}_q] , \quad (17.312)$$

where \mathcal{H}_q is the Hamiltonian (17.71), thus

$$\begin{aligned} \frac{d\sigma_z}{dt} &= \frac{1}{2i} [\sigma_z, \omega_+ \sigma_+ + \omega_- \sigma_- + (\omega_z + \omega_0) \sigma_z] \\ &= i(\omega_- \sigma_- - \omega_+ \sigma_+) , \end{aligned} \quad (17.313)$$

and

$$\begin{aligned} \frac{d\sigma_+}{dt} &= \frac{1}{2i} [\sigma_+, \omega_+ \sigma_+ + \omega_- \sigma_- + (\omega_z + \omega_0) \sigma_z] \\ &= -i \frac{\omega_- \sigma_z}{2} + i(\omega_z + \omega_0) \sigma_+ , \end{aligned} \quad (17.314)$$

where

$$\omega_{\pm} = \omega_x \mp i\omega_y . \quad (17.315)$$

Similarly to the above derivation of the Bloch equations [compare with Eqs. (17.115), (17.116), (17.117) and (17.118)], averaging is performed using the formal solutions of Eqs. (17.313) and (17.314), which are given by

$$\sigma_z(t) = \sigma_z(0) + i \int_0^t dt' (\omega_-(t') \sigma_-(t') - \omega_+(t') \sigma_+(t')) , \quad (17.316)$$

and

$$\sigma_+(t) = \sigma_+(0) e^{i\omega_0 t} + \int_0^t dt' \left(-i \frac{\omega_-(t') \sigma_z(t')}{2} + i\omega_z(t') \sigma_+(t') \right) e^{-i\omega_0(t'-t)} , \quad (17.317)$$

and thus averaging yields

$$\frac{dP_z}{dt} = -\frac{P_z}{T_{s1}} , \quad (17.318)$$

and

$$\frac{dP_+}{dt} = i\omega_0 P_+ - \frac{P_+}{T_{s2}}, \quad (17.319)$$

where $\mathbf{P} = (\langle \sigma_x \rangle, \langle \sigma_y \rangle, \langle \sigma_z \rangle)$ and where the longitudinal T_{s1}^{-1} and transverse T_{s2}^{-1} relaxation rates are given by [see Eq. (17.151) and note that the integration from 0 to t is approximated by half the integration from $-\infty$ to ∞]

$$\begin{aligned} \frac{1}{T_{s1}} &= \frac{1}{4} \int_{-\infty}^{\infty} dt' (\langle \omega_-(t) \omega_+(t') \rangle + \langle \omega_+(t) \omega_-(t') \rangle) e^{-i\omega_0(t'-t)} \\ &= \frac{2\omega_s^2 \tau_s}{1 + \omega_0^2 \tau_s^2}, \end{aligned} \quad (17.320)$$

and

$$\begin{aligned} \frac{1}{T_{s2}} &= \frac{1}{4} \int_{-\infty}^{\infty} dt' \langle \omega_-(t) \omega_+(t') \rangle + \frac{1}{2} \int_{-\infty}^{\infty} dt' \langle \omega_z(t) \omega_z(t') \rangle e^{-i\omega_0(t'-t)} \\ &= \omega_s^2 \tau_s + \frac{\omega_s^2 \tau_s}{1 + \omega_0^2 \tau_s^2}. \end{aligned} \quad (17.321)$$

9. In the rotating frame the Bloch equations are given by Eqs. (17.296) and (17.297), where ω_1 is given by Eq. (15.43). In steady state, i.e. when $\dot{P}_{R+} = 0$, Eq. (17.297) yields

$$P_{R+} = \frac{-i\omega_1 P_z}{i(\omega - \omega_0) - \frac{1}{T_2}}. \quad (17.322)$$

The following holds (note that $P_{R-} = P_{R+}^*$)

$$\frac{i\omega_1 (P_{R+} - P_{R-})}{2} = -\frac{P_z}{T_{1L}}, \quad (17.323)$$

where T_{1L}^{-1} , which is given by

$$T_{1L}^{-1} = \frac{\omega_1^2 T_2}{1 + (\omega_0 - \omega)^2 T_2^2}, \quad (17.324)$$

is the laser-induced transition rate, and thus Eq. (17.296) can be rewritten as

$$\dot{P}_z = -\frac{P_z}{T_{1L}} - \frac{P_z - P_{z0}}{T_1} = -\frac{P_z - P_{z0}\Gamma}{T_{1T}}, \quad (17.325)$$

where T_{1T}^{-1} , which is given by

$$\frac{1}{T_{1T}} = \frac{1}{T_{1L}} + \frac{1}{T_1}, \quad (17.326)$$

is the effective longitudinal decay rate, and P_{z0T} which is given by

$$P_{z0T} = \frac{T_{1T}P_{z0}}{T_1}, \quad (17.327)$$

is the z component of the steady state effective polarization vector. The probability p_e is related to P_z by

$$p_e = \frac{1 + P_{z0T}}{2} = \frac{1 + \frac{T_{1T}P_{z0}}{T_1}}{2}, \quad (17.328)$$

and thus $p_e \simeq (1 + P_{z0})/2$ when $T_{1L}^{-1} \ll T_1^{-1}$, and $p_e \simeq 1/2$ in the opposite limit when $T_{1L}^{-1} \gg T_1^{-1}$. The angular frequency ω_1 given by Eq. (15.43) can be expressed as [note that the laser intensity I_L is the magnitude of the time averaged Poynting vector $\langle \mathbf{S} \rangle$ given by Eq. (15.39)]

$$\omega_1 = \frac{2e|d_p|}{\hbar} \sqrt{\frac{2\pi}{c} I_L}, \quad (17.329)$$

where the matrix element d_p is given by [see Eq. (15.78)]

$$\begin{aligned} d_p &= \langle n' = 2, l' = 1, m' = 1 | \frac{x - iy}{\sqrt{2}} | n = 1, l = 0, m = 0 \rangle \\ &= \sqrt{\frac{1}{2}} \int_0^\infty dr r^3 R_{21} R_{10} \int_{-1}^1 d(\cos \theta) \int_0^{2\pi} d\phi \sin \theta e^{-i\phi} (Y_1^1)^* Y_0^0 \\ &= -\frac{2^{15/2}}{3^5} a_0, \end{aligned} \quad (17.330)$$

where a_0 is Bohr's radius [see Eq. (7.64)], and thus [see Eq. (17.324)]

$$\begin{aligned} T_{1L}^{-1} &= \frac{\frac{2^{18}\pi}{3^{10}} \frac{e^2 a_0^2 I_L T_2}{\hbar^2 c}}{1 + (\omega_0 - \omega)^2 T_2^2} \\ &= \frac{\frac{I_L \sigma \lambda}{hc}}{1 + (\omega_0 - \omega)^2 T_2^2}, \end{aligned} \quad (17.331)$$

where

$$\sigma = \frac{2^{18}\pi\alpha_{fs}}{3^{10}} \omega_0 T_2 a_0^2 = 0.101 \times \omega_0 T_2 a_0^2, \quad (17.332)$$

$\alpha_{fs} = e^2/\hbar c \simeq 1/137$ is the fine-structure constant, and $\lambda = 2\pi c/\omega_0$ is the laser wavelength.

10. With the help of the relations

$$\rho = \begin{pmatrix} \frac{1+k_z}{2} & \frac{k_x-ik_y}{2} \\ \frac{k_x+ik_y}{2} & \frac{1-k_z}{2} \end{pmatrix}, \quad (17.333)$$

$$\mathcal{D}_\rho(\sigma_-) = - \begin{pmatrix} 2(1+k_z) & k_x-ik_y \\ k_x+ik_y & -2(1+k_z) \end{pmatrix}, \quad (17.334)$$

$$\mathcal{D}_\rho(\sigma_+) = \mathcal{D}_\rho(\sigma_-) + 4\sigma_z, \quad (17.335)$$

and

$$\mathcal{D}_\rho(\sigma_z) = - \begin{pmatrix} 0 & k_x-ik_y \\ k_x+ik_y & 0 \end{pmatrix}, \quad (17.336)$$

one finds that [see Eqs. (6.138) and (17.152)]

$$\frac{d\rho}{dt} = \frac{\boldsymbol{\omega} \times \mathbf{k} - T_2^{-1}(k_x, k_y, 0) - T_1^{-1}(0, 0, k_z - k_{z0})}{2} \cdot \boldsymbol{\sigma}, \quad (17.337)$$

where $T_1 = \Gamma_1^{-1}(2\hat{n}_0 + 1)^{-1}$, $T_2 = (\Gamma_1/2 + \Gamma_\varphi)^{-1}(2\hat{n}_0 + 1)^{-1}$ [compare with Eqs. (17.126) and (17.127)], and where $k_{z0} = -(2\hat{n}_0 + 1)^{-1}$ [compare with Eq. (17.125)], thus [compare with Eqs. (17.128), (17.129) and (17.130)]

$$\frac{dk_x}{dt} = \text{Tr} \left(\frac{d\rho}{dt} \sigma_x \right) = (\boldsymbol{\omega} \times \mathbf{k})_x - \frac{k_x}{T_2}, \quad (17.338)$$

$$\frac{dk_y}{dt} = \text{Tr} \left(\frac{d\rho}{dt} \sigma_y \right) = (\boldsymbol{\omega} \times \mathbf{k})_y - \frac{k_y}{T_2}, \quad (17.339)$$

and

$$\frac{dk_z}{dt} = \text{Tr} \left(\frac{d\rho}{dt} \sigma_z \right) = (\boldsymbol{\omega} \times \mathbf{k})_z - \frac{k_z - k_{z0}}{T_1}. \quad (17.340)$$

11. The following holds [recall that $\langle S \rangle = \text{Tr}(\rho S)$, and see Eqs. (17.156) and (2.134)]

$$\begin{aligned} \frac{d \text{Tr} \rho}{dt} &= \text{Tr} (i\hbar^{-1} [\rho, \mathcal{H}] + \gamma(\rho S + S\rho - 2\rho \langle S \rangle)) \\ &= 2\gamma \langle S \rangle (1 - \text{Tr} \rho), \end{aligned} \quad (17.341)$$

hence $\text{Tr} \rho(t) = 1$ provided that $\text{Tr} \rho_0 = 1$ [see Eq. (8.12)].

a) Note that the following holds

$$\frac{d\varrho}{dt} = i\hbar^{-1} [\varrho, \mathcal{H}] + \gamma(\varrho S + S\varrho). \quad (17.342)$$

Substituting Eq. (17.158) into Eq. (17.156) yields [see Eq. (17.342)]

$$\left(\frac{d \log \alpha}{dt} + 2\gamma \langle S \rangle \right) \rho = 0, \quad (17.343)$$

where

$$\alpha = \frac{1}{\text{Tr}(\varrho(t))}. \quad (17.344)$$

By employing the condition $\text{Tr} \rho(t) = 1$ to determine the real coefficient a one finds that Eq. (17.158) holds. Alternatively, Eq. (17.343) yields

$$\alpha(t) = \alpha(0) \exp\left(-2\gamma \int_0^t dt' \langle S \rangle\right). \quad (17.345)$$

b) The following holds [see Eq. (17.156)]

$$\begin{aligned} \frac{d \text{Tr} \rho^2}{dt} &= 2 \text{Tr} \left(\rho \frac{d\rho}{dt} \right) \\ &= 2 \text{Tr} (i\hbar^{-1} \rho [\rho, \mathcal{H}] + \gamma \rho (\rho S + S \rho - 2\rho \langle S \rangle)) . \end{aligned} \quad (17.346)$$

For the case $\rho^2 = \rho$ this yields [see Eq. (2.134), and recall that $\text{Tr} \rho = 1$]

$$\frac{d \text{Tr} \rho^2}{dt} = 2\gamma \text{Tr} (\rho S - \rho \langle S \rangle) = 0. \quad (17.347)$$

c) The following holds [see Eq. (17.156)]

$$\frac{d \langle A \rangle}{dt} = \text{Tr} ((i\hbar^{-1} [\rho, \mathcal{H}] + \gamma (\rho S + S \rho - 2\rho \langle S \rangle)) A), \quad (17.348)$$

hence Eq. (17.160) holds [see Eq. (2.134)].

d) For the observable $A = \mathbf{a} \cdot \boldsymbol{\sigma}$, where $\mathbf{a} = (a_x, a_y, a_z)$ Eq. (17.160) yields

$$\begin{aligned} &\frac{d \text{Tr} \left(\frac{1+\mathbf{k} \cdot \boldsymbol{\sigma}}{2} \mathbf{a} \cdot \boldsymbol{\sigma} \right)}{dt} \\ &= i \text{Tr} \left(\frac{1+\mathbf{k} \cdot \boldsymbol{\sigma}}{2} [\boldsymbol{\omega} \cdot \boldsymbol{\sigma}, \mathbf{a} \cdot \boldsymbol{\sigma}] \right) \\ &\quad + \gamma \text{Tr} \left(\frac{1+\mathbf{k} \cdot \boldsymbol{\sigma}}{2} ((\mathbf{a} \cdot \boldsymbol{\sigma})(\mathbf{s} \cdot \boldsymbol{\sigma}) + (\mathbf{s} \cdot \boldsymbol{\sigma})(\mathbf{a} \cdot \boldsymbol{\sigma})) \right) \\ &\quad - 2\gamma \text{Tr} \left(\frac{1+\mathbf{k} \cdot \boldsymbol{\sigma}}{2} \mathbf{s} \cdot \boldsymbol{\sigma} \right) \text{Tr} \left(\frac{1+\mathbf{k} \cdot \boldsymbol{\sigma}}{2} \mathbf{a} \cdot \boldsymbol{\sigma} \right), \end{aligned} \quad (17.349)$$

or [recall that $\text{Tr} \sigma_x = \text{Tr} \sigma_y = \text{Tr} \sigma_z = 0$, and see Eq. (6.138)]

$$\begin{aligned} \frac{d(\mathbf{a} \cdot \mathbf{k})}{dt} &= -2\mathbf{k} \cdot (\boldsymbol{\omega} \times \mathbf{a}) \\ &+ 2\gamma(\mathbf{a} \cdot \mathbf{s} - (\mathbf{s} \cdot \mathbf{k})(\mathbf{a} \cdot \mathbf{k})) , \end{aligned} \quad (17.350)$$

thus Eq. (17.165) holds [note that $\mathbf{k} \cdot (\boldsymbol{\omega} \times \mathbf{a}) = \mathbf{a} \cdot (\mathbf{k} \times \boldsymbol{\omega})$, and compare with Eqs. (17.128), (17.129) and (17.130)].

e) For this case and when $d\mathbf{k}/dt = 0$ (steady state) Eq. (17.165) yields

$$0 = \hat{\mathbf{z}} \times \mathbf{k} + g(\hat{\mathbf{s}} - p\mathbf{k}) , \quad (17.351)$$

where $\mathbf{s} = s\hat{\mathbf{s}}$, $\hat{\mathbf{s}} = (\sin\theta \cos\phi, \sin\theta \sin\phi, \cos\theta)$ is a unit vector, $p = \hat{\mathbf{s}} \cdot \mathbf{k}$, and $g = \gamma s/\omega$, thus

$$0 = -k_y + g(\sin\theta \cos\phi - pk_x) , \quad (17.352)$$

$$0 = k_x + g(\sin\theta \sin\phi - pk_y) , \quad (17.353)$$

$$0 = \cos\theta - pk_z \quad (17.354)$$

hence

$$k_x = g \frac{gp \cos\phi - \sin\phi}{1 + g^2 p^2} \sin\theta , \quad (17.355)$$

$$k_y = g \frac{gp \sin\phi + \cos\phi}{1 + g^2 p^2} \sin\theta , \quad (17.356)$$

$$k_z = \frac{\cos\theta}{p} . \quad (17.357)$$

The relation $p = \hat{\mathbf{s}} \cdot \mathbf{k}$ yields

$$\begin{aligned} p &= k_x \sin\theta \cos\phi + k_y \sin\theta \sin\phi + k_z \cos\theta \\ &= \left(\frac{g^2 p}{1 + g^2 p^2} - \frac{1}{p} \right) \sin^2\theta + \frac{1}{p} . \end{aligned} \quad (17.358)$$

The solutions of Eq. (17.358) are given by

$$p^2 = \frac{g^2 - 1 \pm (g^2 + 1) \sqrt{1 - \left(\frac{2g \sin\theta}{g^2 + 1} \right)^2}}{2g^2} . \quad (17.359)$$

For a given p , the vector \mathbf{k} can be obtained from Eqs. (17.355), (17.356) and (17.357). Physically acceptable solutions must satisfy $p^2 \geq 0$ and $\mathbf{k} \cdot \mathbf{k} \leq 1$.

f) The following holds for \mathbf{k} as given by Eq. (17.169)

$$\begin{aligned} \frac{d\mathbf{k}}{dt} &= 2\gamma \hat{\mathbf{s}} \frac{\cosh(2\gamma t) + (\hat{\mathbf{s}} \cdot \mathbf{k}_0) \sinh(2\gamma t)}{\cosh(2\gamma t) + (\hat{\mathbf{s}} \cdot \mathbf{k}_0) \sinh(2\gamma t)} - 2\gamma \frac{\sinh(2\gamma t) + (\hat{\mathbf{s}} \cdot \mathbf{k}_0) \cosh(2\gamma t)}{\cosh(2\gamma t) + (\hat{\mathbf{s}} \cdot \mathbf{k}_0) \sinh(2\gamma t)} \mathbf{k} \\ &= 2\gamma \hat{\mathbf{s}} - 2\gamma \frac{\sinh(2\gamma t) + (\hat{\mathbf{s}} \cdot \mathbf{k}_0) \cosh(2\gamma t)}{\cosh(2\gamma t) + (\hat{\mathbf{s}} \cdot \mathbf{k}_0) \sinh(2\gamma t)} \mathbf{k} , \end{aligned} \quad (17.360)$$

and (recall that $\hat{\mathbf{s}} \cdot \hat{\mathbf{s}} = 1$)

$$\begin{aligned}\hat{\mathbf{s}} \cdot \mathbf{k} &= \frac{\hat{\mathbf{s}} \cdot \mathbf{k}_0 + \sinh(2\gamma t) + (\cosh(2\gamma t) - 1)(\hat{\mathbf{s}} \cdot \mathbf{k}_0)}{\cosh(2\gamma t) + (\hat{\mathbf{s}} \cdot \mathbf{k}_0) \sinh(2\gamma t)} \\ &= \frac{\sinh(2\gamma t) + (\hat{\mathbf{s}} \cdot \mathbf{k}_0) \cosh(2\gamma t)}{\cosh(2\gamma t) + (\hat{\mathbf{s}} \cdot \mathbf{k}_0) \sinh(2\gamma t)},\end{aligned}\tag{17.361}$$

thus Eq. (17.168) is satisfied by \mathbf{k} as given by Eq. (17.169).

12. With the help of Kubo's identity (2.186) one finds that [the transformation $\lambda = \beta(1 - q)$ is being used]

$$\begin{aligned}[Q, e^{-\beta\mathcal{H}}] &= e^{-\beta\mathcal{H}} \int_0^\beta e^{\lambda\mathcal{H}} [\mathcal{H}, Q] e^{-\lambda\mathcal{H}} d\lambda \\ &= \beta \int_0^1 (e^{-\beta\mathcal{H}})^q [\mathcal{H}, Q] (e^{-\beta\mathcal{H}})^{1-q} dq,\end{aligned}\tag{17.362}$$

hence [see Eq. (17.171)]

$$[Q, \rho_0] = \beta [\mathcal{H}, Q]_{\rho_0} .\tag{17.363}$$

- a) Clearly $[\rho_0, \mathcal{H}] = 0$, since ρ_0 is a function of \mathcal{H} [see Eq. (17.172)], hence $\Theta_u(\rho_0) = 0$. Moreover, $\Theta_d(\rho_0) = 0$ [see Eq. (17.363)], hence ρ_0 is a fixed point of Eq. (17.170).
b) With the help of Eq. (2.187) one finds that

$$\begin{aligned}\Theta_d(\rho) &= \Theta_A(\rho) + \Theta_B(\rho) \\ &= \beta\gamma_E [Q, \beta^{-1} [Q, \rho] + [Q, \mathcal{H}]_\rho] \\ &= \beta\gamma_E [Q, \beta^{-1} [Q, \log \rho] + [Q, \mathcal{H}]_\rho] .\end{aligned}\tag{17.364}$$

The following holds [see Eq. (17.171)]

$$[Q, \log \rho] = \int_0^1 dq \rho^q [Q, \log \rho] \rho^{1-q} = [Q, \log \rho]_\rho ,$$

thus Eq. (17.173) holds.

- c) With the help of Eqs. (17.171) and (2.134) one finds that

$$\begin{aligned}\text{Tr}(A_\rho B) &= \text{Tr} \left(\int_0^1 dq \rho^q A \rho^{1-q} B \right) \\ &= \text{Tr} \left(\int_0^1 dq \rho^{1-q} B \rho^q A \right) \\ &= \text{Tr} \left(\int_0^1 dq \rho^q B \rho^{1-q} A \right) ,\end{aligned}\tag{17.365}$$

hence Eq. (17.175) holds.

- d) Let $\{|n\rangle\}$ be a basis of eigenvectors of the operator ρ , and let $\{\rho_n\}$ be the corresponding eigenvalues. The following holds $\rho|n\rangle = \rho_n|n\rangle$, and $0 \leq \rho_n \leq 1$ [see inequality (8.20)], hence [see Eq. (2.23)]

$$\begin{aligned} \text{Tr}(A_\rho B) &= \text{Tr} \left(\int_0^1 dq \rho^q A \rho^{1-q} B \right) \\ &= \sum_{n,m} \int_0^1 dq \langle n | \rho^q A \rho^{1-q} | m \rangle \langle m | B | n \rangle \\ &= \sum_{n,m} \langle n | A | m \rangle \langle m | B | n \rangle \mathcal{F}(\rho_n, \rho_m) , \end{aligned} \tag{17.366}$$

where

$$\begin{aligned} \mathcal{F}(x, y) &= \int_0^1 dq x^q y^{1-q} \\ &= \frac{x-y}{\log x - \log y} \\ &= \frac{x+y}{2} \frac{\frac{x-y}{x+y}}{\tanh^{-1} \frac{x-y}{x+y}} . \end{aligned} \tag{17.367}$$

Note that $\mathcal{F}(x, y) = \mathcal{F}(y, x)$ and that $0 \leq \mathcal{F}(\rho_n, \rho_m) \leq 1$. For the case $A = B$

$$\text{Tr}(A_\rho A) = \sum_{n,m} |\langle n | A | m \rangle|^2 \mathcal{F}(\rho_n, \rho_m) , \tag{17.368}$$

thus (17.176) holds.

- e) The following holds [see Eq. (17.171)]

$$\text{Tr}(A_\rho) = \text{Tr} \left(\int_0^1 dq \rho^q A \rho^{1-q} \right) = \text{Tr}(A\rho) , \tag{17.369}$$

hence (17.177) holds.

- f) With the help of Eqs. (17.170) and (17.173) one finds that [recall that \mathcal{H} is time-independent, note that $\text{Tr} \rho = 1$, hence $\text{Tr}(\rho^{-1} (d\rho/dt) \rho) = \text{Tr}(d\rho/dt) = (d/dt) \text{Tr}(\rho) = 0$, and see Eq. (2.185)]

$$\begin{aligned} \frac{d\langle \mathcal{U}_H \rangle}{dt} &= \text{Tr} \left(\frac{d\mathcal{U}_H}{dt} \rho \right) + \text{Tr} \left(\mathcal{U}_H \frac{d\rho}{dt} \right) \\ &= \beta^{-1} \text{Tr} \left(\frac{d \log \rho}{dt} \rho \right) + \text{Tr} \left(\mathcal{U}_H \frac{d\rho}{dt} \right) \\ &= \text{Tr} \left((\mathcal{H} + \beta^{-1} \log \rho) \frac{d\rho}{dt} \right) , \end{aligned} \tag{17.370}$$

thus [see Eqs. (17.170), (17.173) and (2.134)]

$$\begin{aligned}
 \frac{d\langle \mathcal{U}_H \rangle}{dt} &= \frac{i}{\hbar} \text{Tr} \left((\mathcal{H} + \beta^{-1} \log \rho) [\rho, \mathcal{H}] \right) \\
 &\quad - \beta \gamma_E \text{Tr} \left(\mathcal{U}_H \left[Q, [Q, \mathcal{U}_H]_\rho \right] \right) \\
 &= -\beta \gamma_E \text{Tr} \left(\mathcal{U}_H \left[Q, [Q, \mathcal{U}_H]_\rho \right] \right) \\
 &= -\beta \gamma_E \text{Tr} \left(i [Q, \mathcal{U}_H] i [Q, \mathcal{U}_H]_\rho \right),
 \end{aligned} \tag{17.371}$$

and therefore (17.178) holds. Note that $\mathcal{C} = 0$ when $\rho = \rho_0$ [see Eqs. (8.36), (17.174) and (17.179)].

g) By using Eqs. (17.176) and (17.178) one finds that $d\langle \mathcal{U}_H \rangle / dt \leq 0$.

13. With the help of Eq. (14.73), the commutation relations (14.75) and (14.76), the relations

$$\omega_{\mathbf{k}} = c |\mathbf{k}|, \tag{17.372}$$

$$\hat{\mathbf{e}}_{\mathbf{k},\lambda}^* \cdot \hat{\mathbf{e}}_{\mathbf{k},\lambda'} = \delta_{\lambda,\lambda'}, \tag{17.373}$$

$$\hat{\mathbf{e}}_{\mathbf{k},\lambda} \cdot \mathbf{k} = \hat{\mathbf{e}}_{\mathbf{k},\lambda}^* \cdot \mathbf{k} = 0, \tag{17.374}$$

and the thermal expectation values (17.51), (17.52), (17.53) and (17.54) one finds that the correlation function (17.180) can be expressed as

$$\begin{aligned}
 C(\mathbf{r}', t') &= \sum_{\mathbf{k}, \lambda} \frac{2\pi c^2 \hbar}{\omega_{\mathbf{k}} V} \left(e^{-i(\mathbf{k} \cdot \mathbf{r}' - \omega_{\mathbf{k}} t')} \langle a_{\mathbf{k},\lambda} a_{\mathbf{k},\lambda}^\dagger \rangle + e^{i(\mathbf{k} \cdot \mathbf{r}' - \omega_{\mathbf{k}} t')} \langle a_{\mathbf{k},\lambda}^\dagger a_{\mathbf{k},\lambda} \rangle \right) \\
 &= \sum_{\mathbf{k}} \frac{4\pi c^2 \hbar}{\omega_{\mathbf{k}} V} \left[e^{-i(\mathbf{k} \cdot \mathbf{r}' - \omega_{\mathbf{k}} t')} (\hat{n}_{\mathbf{k}} + 1) + e^{i(\mathbf{k} \cdot \mathbf{r}' - \omega_{\mathbf{k}} t')} \hat{n}_{\mathbf{k}} \right],
 \end{aligned} \tag{17.375}$$

where [see Eq. (17.44)]

$$\hat{n}_{\mathbf{k}} = \frac{1}{e^{\beta \hbar c k} - 1}, \tag{17.376}$$

and where $\beta = 1/(k_B T)$. The discrete sum over wave vectors \mathbf{k} can be replaced by an integral [see Eq. (14.74) and note that the z axis is chosen in the direction of \mathbf{r}']

$$\begin{aligned}
 C(\mathbf{r}', t') &= \int_0^\infty dk k^2 \int_{-1}^1 d(\cos \theta) \frac{c \hbar \left[e^{-i(kr' \cos \theta - ckt')} (\hat{n}_k + 1) + e^{i(kr' \cos \theta - ckt')} \hat{n}_k \right]}{\pi k} \\
 &= \int_0^\infty dk \frac{\sin(kr')}{r'} \frac{2c \hbar \left[e^{ickt'} (\hat{n}_k + 1) + e^{-ickt'} \hat{n}_k \right]}{\pi} \\
 &= \frac{2\hbar}{\pi r' t'} \int_0^\infty dx \sin(Rx) \left[\left(\coth \frac{Kx}{2} - 1 \right) \cos x + e^{ix} \right],
 \end{aligned} \tag{17.377}$$

where

$$K = \frac{\beta\hbar}{t'}, R = \frac{r'}{ct'}.$$

a) For the case $r' = 0$ Eq. (17.377) becomes

$$C(0, t') = \frac{2\hbar}{\pi ct'^2} \int_0^\infty dx x \left[\left(\coth \frac{Kx}{2} - 1 \right) \cos x + e^{ix} \right]. \quad (17.378)$$

The first integral can be calculated as follows

$$\begin{aligned} & \int_0^\infty dx x \left[\left(\coth \frac{Kx}{2} - 1 \right) \cos x \right] \\ &= \lim_{A \rightarrow 1} \frac{\partial}{\partial A} \int_0^\infty dx \left[\left(\coth \frac{Kx}{2} - 1 \right) \sin(Ax) \right] \\ & \frac{\pi^2 (1 - \coth^2 \frac{\pi}{K})}{K^2} + 1. \end{aligned} \quad (17.379)$$

The second integral, which does not converge, is regularized as follows

$$\int_0^\infty dx x e^{ix} \rightarrow \lim_{G \rightarrow 0} \int_0^\infty dx x e^{(i-G)x} = -1,$$

and thus

$$C(0, t') = \frac{2\hbar}{\pi ct'^2} \left(\frac{\pi^2 (1 - \coth^2 \frac{\pi}{K})}{K^2} \right) = -\frac{2\hbar}{\pi c} \frac{\left(\frac{\pi k_B T}{\hbar} \right)^2}{\sinh^2 \left(\frac{\pi k_B T t'}{\hbar} \right)}. \quad (17.380)$$

b) For the case $T = 0$ Eq. (17.377) becomes

$$\begin{aligned} C(\mathbf{r}', t') &= \frac{2\hbar}{\pi r' t'} \int_0^\infty dx \sin(Rx) e^{ix} \\ &\rightarrow \frac{2\hbar}{\pi r' t'} \lim_{G \rightarrow 0} \int_0^\infty dx \sin(Rx) e^{(i-G)x} \\ &= \frac{2\hbar}{\pi r' t'} \frac{1}{R - \frac{1}{R}}, \end{aligned} \quad (17.381)$$

thus

$$C(\mathbf{r}', t') = \frac{2\hbar c}{\pi} \frac{1}{(r')^2 - (ct')^2}. \quad (17.382)$$

c) With the help of Eqs. (17.181), (17.182) and (17.382) one finds that the value of the correlation function $C(\mathbf{r}', t')$ as being measured by the accelerated observer is given by

$$\begin{aligned}
 & C(x(\tau_2) - x(\tau_1), t(\tau_2) - t(\tau_1)) \\
 &= \frac{2\hbar a^2}{\pi c^3} \frac{1}{\left(\cosh \frac{a\tau_2}{c} - \cosh \frac{a\tau_1}{c}\right)^2 - \left(\sinh \frac{a\tau_2}{c} - \sinh \frac{a\tau_1}{c}\right)^2} \\
 &= -\frac{\hbar a^2}{\pi c^3} \frac{1}{\cosh \frac{a(\tau_2 - \tau_1)}{c} - 1} \\
 &= -\frac{\hbar a^2}{\pi c^3} \frac{1}{2 \sinh^2 \frac{a(\tau_2 - \tau_1)}{2c}}.
 \end{aligned} \tag{17.383}$$

The above can be rewritten as [see Eqs. (17.182) and (17.183)]

$$C(x(\tau_2) - x(\tau_1), t(\tau_2) - t(\tau_1)) = -\frac{2\hbar}{\pi c} \frac{\left(\frac{\pi k_B T_{\text{UD}}}{\hbar}\right)^2}{\sinh^2 \left(\frac{\pi k_B T_{\text{UD}}(\tau_2 - \tau_1)}{\hbar}\right)}, \tag{17.384}$$

which implies that the effective temperature is T_{UD} [see Eq. (17.380)].

14. The matrix representation of \mathcal{H}_0 and \mathcal{H}_p is given by

$$\frac{\mathcal{H}_0}{\hbar} \doteq \begin{pmatrix} -\omega_0 & 0 & 0 & -\frac{\omega_0 \vartheta}{2} \\ 0 & 0 & 0 & 0 \\ 0 & 0 & 0 & 0 \\ -\frac{\omega_0 \vartheta}{2} & 0 & 0 & \omega_0 \end{pmatrix}, \tag{17.385}$$

and

$$\frac{\mathcal{H}_p}{\hbar} \doteq \begin{pmatrix} \omega_{\text{L1}} \cos(\omega_{\text{L}} t + \theta) & \frac{\omega_{\text{T1}} e^{i\omega_{\text{T}} t}}{2} & \frac{\omega_{\text{T1}} e^{i\omega_{\text{T}} t}}{2} & 0 \\ \frac{\omega_{\text{T1}} e^{-i\omega_{\text{T}} t}}{2} & 0 & 0 & \frac{\omega_{\text{T1}} e^{i\omega_{\text{T}} t}}{2} \\ \frac{\omega_{\text{T1}} e^{-i\omega_{\text{T}} t}}{2} & 0 & 0 & \frac{\omega_{\text{T1}} e^{i\omega_{\text{T}} t}}{2} \\ 0 & \frac{\omega_{\text{T1}} e^{-i\omega_{\text{T}} t}}{2} & \frac{\omega_{\text{T1}} e^{-i\omega_{\text{T}} t}}{2} & -\omega_{\text{L1}} \cos(\omega_{\text{L}} t + \theta) \end{pmatrix}. \tag{17.386}$$

The following hold

$$S_{a+} = S_{ax} + iS_{ay} \doteq \begin{pmatrix} 0 & 0 & 2 & 0 \\ 0 & 0 & 0 & 2 \\ 0 & 0 & 0 & 0 \\ 0 & 0 & 0 & 0 \end{pmatrix}, \quad (17.387)$$

$$S_{a-} = S_{ax} - iS_{ay} \doteq \begin{pmatrix} 0 & 0 & 0 & 0 \\ 0 & 0 & 0 & 0 \\ 2 & 0 & 0 & 0 \\ 0 & 2 & 0 & 0 \end{pmatrix}, \quad (17.388)$$

$$S_{b+} = S_{bx} + iS_{by} \doteq \begin{pmatrix} 0 & 2 & 0 & 0 \\ 0 & 0 & 0 & 0 \\ 0 & 0 & 0 & 2 \\ 0 & 0 & 0 & 0 \end{pmatrix}, \quad (17.389)$$

$$S_{b-} = S_{bx} - iS_{by} \doteq \begin{pmatrix} 0 & 0 & 0 & 0 \\ 2 & 0 & 0 & 0 \\ 0 & 0 & 0 & 0 \\ 0 & 0 & 2 & 0 \end{pmatrix}, \quad (17.390)$$

$$\frac{S_+}{4} = \frac{S_x + iS_y}{4} \doteq \begin{pmatrix} 0 & \frac{1}{2} & \frac{1}{2} & 0 \\ 0 & 0 & 0 & \frac{1}{2} \\ 0 & 0 & 0 & \frac{1}{2} \\ 0 & 0 & 0 & 0 \end{pmatrix}, \quad (17.391)$$

$$\frac{S_-}{4} = \frac{1}{4}(S_x - iS_y) = \begin{pmatrix} 0 & 0 & 0 & 0 \\ \frac{1}{2} & 0 & 0 & 0 \\ \frac{1}{2} & 0 & 0 & 0 \\ 0 & \frac{1}{2} & \frac{1}{2} & 0 \end{pmatrix}, \quad (17.392)$$

and

$$\frac{(S_+)^2}{16} \doteq \begin{pmatrix} 0 & 0 & 0 & \frac{1}{2} \\ 0 & 0 & 0 & 0 \\ 0 & 0 & 0 & 0 \\ 0 & 0 & 0 & 0 \end{pmatrix}, \quad (17.393)$$

$$\frac{(S_-)^2}{16} \doteq \begin{pmatrix} 0 & 0 & 0 & 0 \\ 0 & 0 & 0 & 0 \\ 0 & 0 & 0 & 0 \\ \frac{1}{2} & 0 & 0 & 0 \end{pmatrix}, \quad (17.394)$$

- a) The relations (17.190), (17.191) and (17.192) can be obtained using Eqs. (4.38) and (17.188).
- b) The relation (17.193) can be obtained using Eq. (6.139).
- c) The following holds [see Eq. (17.385)]

$$\frac{\mathcal{H}_0}{\hbar} \doteq -\omega_e \begin{pmatrix} \cos(2J) & 0 & 0 & \sin(2J) \\ 0 & 0 & 0 & 0 \\ 0 & 0 & 0 & 0 \\ \sin(2J) & 0 & 0 & -\cos(2J) \end{pmatrix}, \quad (17.395)$$

where [see Eq. (17.194)]

$$\tan(2J) = \frac{\vartheta}{2}, \quad (17.396)$$

hence Eq. (17.195) holds.

d) The relation (17.197) is obtained using Eq. (17.386).

e) The following holds

$$\begin{aligned} \frac{\mathcal{H}''}{\hbar} = & \begin{pmatrix} -\omega_e - \omega_T & 0 & 0 & 0 \\ 0 & 0 & 0 & 0 \\ 0 & 0 & 0 & 0 \\ 0 & 0 & 0 & \omega_e + \omega_T \end{pmatrix} \\ & + \omega_{L1} \cos(\omega_L t + \theta) \begin{pmatrix} \cos(2J) & 0 & 0 & -e^{2i\omega_T t} \sin(2J) \\ 0 & 0 & 0 & 0 \\ 0 & 0 & 0 & 0 \\ -e^{-2i\omega_T t} \sin(2J) & 0 & 0 & -\cos(2J) \end{pmatrix} \\ & + \omega_{T1} \begin{pmatrix} 0 & \frac{\cos J + e^{2i\omega_T t} \sin J}{2} & \frac{\cos J + e^{2i\omega_T t} \sin J}{2} & 0 \\ \frac{\cos J + e^{-2i\omega_T t} \sin J}{2} & 0 & 0 & \frac{\cos J - e^{-2i\omega_T t} \sin J}{2} \\ \frac{\cos J + e^{-2i\omega_T t} \sin J}{2} & 0 & 0 & \frac{\cos J - e^{2i\omega_T t} \sin J}{2} \\ 0 & \frac{\cos J - e^{-2i\omega_T t} \sin J}{2} & \frac{\cos J - e^{-2i\omega_T t} \sin J}{2} & 0 \end{pmatrix}. \end{aligned} \quad (17.397)$$

Neglecting rapidly oscillating terms leads to Eq. (17.201).

- f) The equations of motion (17.207), (17.208), (17.209), (17.210), (17.211) and (17.212) are obtained using Eqs. (4.38) and (17.201).
 g) The following holds [see Eqs. (17.193) and (17.201)]

$$\begin{aligned}
 u_J \frac{\mathcal{H}_{\text{RWA}}''}{\hbar} u_J^\dagger = & -\omega_{\text{Td}} \begin{pmatrix} \cos 2J & 0 & 0 & e^{2i\phi} \sin 2J \\ 0 & 0 & 0 & 0 \\ 0 & 0 & 0 & 0 \\ e^{-2i\phi} \sin 2J & 0 & 0 & -\cos 2J \end{pmatrix} \\
 & + \Omega_{\text{T1}} \begin{pmatrix} 0 & \frac{\cos J - e^{2i\phi} \sin J}{2} & \frac{\cos J - e^{2i\phi} \sin J}{2} & 0 \\ \frac{\cos J - e^{-2i\phi} \sin J}{2} & 0 & 0 & \frac{\cos J + e^{2i\phi} \sin J}{2} \\ \frac{\cos J - e^{-2i\phi} \sin J}{2} & 0 & 0 & \frac{\cos J + e^{2i\phi} \sin J}{2} \\ 0 & \frac{\cos J + e^{-2i\phi} \sin J}{2} & \frac{\cos J + e^{-2i\phi} \sin J}{2} & 0 \end{pmatrix} \\
 & - \Omega_{\text{L1}} e^{-i\omega_{\text{a}} t} e^{-2i\phi} \begin{pmatrix} -\frac{\sin 2J}{4} & 0 & 0 & \frac{e^{2i\phi} (\cos 2J + 1)}{4} \\ 0 & 0 & 0 & 0 \\ 0 & 0 & 0 & 0 \\ \frac{e^{-2i\phi} (\cos 2J - 1)}{4} & 0 & 0 & \frac{\sin 2J}{4} \end{pmatrix} \\
 & - \Omega_{\text{L1}}^* e^{i\omega_{\text{a}} t} e^{2i\phi} \begin{pmatrix} -\frac{\sin 2J}{4} & 0 & 0 & \frac{e^{2i\phi} (\cos 2J - 1)}{4} \\ 0 & 0 & 0 & 0 \\ 0 & 0 & 0 & 0 \\ \frac{e^{-2i\phi} (\cos 2J + 1)}{4} & 0 & 0 & \frac{\sin 2J}{4} \end{pmatrix}, \tag{17.398}
 \end{aligned}$$

thus Eq. (17.213) holds.

15. Expressing the ket vector state as

$$|\psi\rangle = e^{-i\mathcal{H}_0 t/\hbar} |\psi_{\text{I}}\rangle, \tag{17.399}$$

and substituting into the Schrödinger equation, which is given by

$$i\hbar \frac{d|\psi\rangle}{dt} = (\mathcal{H}_0 + \mathcal{H}_{\text{p}}) |\psi\rangle, \tag{17.400}$$

yield

$$i\hbar \frac{d|\psi_{\text{I}}\rangle}{dt} = \mathcal{H}_{\text{I}} |\psi_{\text{I}}\rangle, \tag{17.401}$$

where \mathcal{H}_{I} , which is given by

$$\mathcal{H}_{\text{I}} = e^{i\mathcal{H}_0 t/\hbar} \mathcal{H}_{\text{p}} e^{-i\mathcal{H}_0 t/\hbar}, \tag{17.402}$$

is the so-called interaction picture representation of \mathcal{H}_{p} .

a) With the help of the vector identity (2.182), which is given by

$$e^L A e^{-L} = A + [L, A] + \frac{1}{2!} [L, [L, A]] + \frac{1}{3!} [L, [L, [L, A]]] + \dots, \tag{17.403}$$

and the relations

$$\frac{it}{\hbar} [\mathcal{H}_0, B_1 B_2] = -2i\omega_0 t B_1 B_2, \quad (17.404)$$

and

$$\frac{it}{\hbar} [\mathcal{H}_0, B_1^\dagger B_2^\dagger] = 2i\omega_0 t B_1^\dagger B_2^\dagger, \quad (17.405)$$

one finds that

$$e^{i\mathcal{H}_0 t/\hbar} B_1 B_2 e^{-i\mathcal{H}_0 t/\hbar} = B_1 B_2 e^{-2i\omega_0 t}, \quad (17.406)$$

$$e^{i\mathcal{H}_0 t/\hbar} B_1^\dagger B_2^\dagger e^{-i\mathcal{H}_0 t/\hbar} = B_1^\dagger B_2^\dagger e^{2i\omega_0 t}, \quad (17.407)$$

thus

$$\mathcal{H}_I = i\hbar\omega_0 \zeta(t) \left(e^{-2i\phi} B_1 B_2 - e^{2i\phi} B_1^\dagger B_2^\dagger \right). \quad (17.408)$$

Since $[\mathcal{H}_I(t), \mathcal{H}_I(t')] = 0$ one has

$$\begin{aligned} |\psi_I(t)\rangle &= \exp\left(-\frac{i}{\hbar} \int_0^t dt' \mathcal{H}_I(t')\right) |\psi_I(0)\rangle \\ &= S(\xi, \phi) |\psi_I(0)\rangle, \end{aligned} \quad (17.409)$$

where

$$S(\xi, \phi) = \exp\left[\xi \left(e^{-2i\phi} B_1 B_2 - e^{2i\phi} B_1^\dagger B_2^\dagger \right)\right], \quad (17.410)$$

and where

$$\xi = \omega_0 \int_0^t dt' \zeta(t'). \quad (17.411)$$

b) Using Eq. (2.182) and the identities

$$\left[-\xi \left(e^{-2i\phi} B_1 B_2 - e^{2i\phi} B_1^\dagger B_2^\dagger \right), B_1 \right] = -\xi e^{2i\phi} B_2^\dagger, \quad (17.412)$$

$$\left[-\xi \left(e^{-2i\phi} B_1 B_2 - e^{2i\phi} B_1^\dagger B_2^\dagger \right), -\xi e^{2i\phi} B_2^\dagger \right] = \xi^2 B_1, \quad (17.413)$$

$$\left[-\xi \left(e^{-2i\phi} B_1 B_2 - e^{2i\phi} B_1^\dagger B_2^\dagger \right), \xi^2 B_1 \right] = -\xi^3 e^{2i\phi} B_2^\dagger, \quad (17.414)$$

$$\left[-\xi \left(e^{-2i\phi} B_1 B_2 - e^{2i\phi} B_1^\dagger B_2^\dagger \right), -\xi^3 e^{2i\phi} B_2^\dagger \right] = \xi^4 B_1, \quad (17.415)$$

⋮

one finds that

$$\begin{aligned}
 S^\dagger(\xi, \phi) B_1 S(\xi, \phi) &= B_1 \left(1 + \frac{\xi^2}{2!} + \frac{\xi^4}{4!} + \dots \right) \\
 &\quad - B_2^\dagger e^{2i\phi} \left(\xi + \frac{\xi^3}{3!} + \dots \right),
 \end{aligned} \tag{17.416}$$

thus

$$S^\dagger(\xi, \phi) B_1 S(\xi, \phi) = B_1 \cosh \xi - B_2^\dagger e^{2i\phi} \sinh \xi, \tag{17.417}$$

and similarly,

$$S^\dagger(\xi, \phi) B_2 S(\xi, \phi) = B_2 \cosh \xi - B_1^\dagger e^{2i\phi} \sinh \xi. \tag{17.418}$$

c) With the help of the commutation relations (17.219) and (17.220) one finds that

$$[A_{n'}, A_{n''}^\dagger] = \delta_{n', n''}, \tag{17.419}$$

$$[A_{n'}, A_{n''}] = [A_{n'}^\dagger, A_{n''}^\dagger] = 0, \tag{17.420}$$

where $n', n'' \in \{1, 2\}$. The operator X_θ can be expressed as

$$\begin{aligned}
 X_\theta &= \cos \theta \frac{B_1 + B_2 + B_1^\dagger + B_2^\dagger}{\sqrt{2}} \\
 &\quad + \sin \theta \frac{B_1 - B_2 + B_1^\dagger - B_2^\dagger}{\sqrt{2}} \\
 &= (\cos \theta + \sin \theta) \frac{B_1 + B_1^\dagger}{\sqrt{2}} \\
 &\quad + (\cos \theta - \sin \theta) \frac{B_2 + B_2^\dagger}{\sqrt{2}} \\
 &= \cos \left(\theta - \frac{\pi}{4} \right) (B_1 + B_1^\dagger) \\
 &\quad + \cos \left(\theta + \frac{\pi}{4} \right) (B_2 + B_2^\dagger).
 \end{aligned} \tag{17.421}$$

Using Eqs. (17.224) and (17.225) one finds that

$$\begin{aligned}
& S^\dagger(\xi, \phi) X_\theta S(\xi, \phi) \\
&= \cos\left(\theta - \frac{\pi}{4}\right) \cosh \xi \left(B_1 + B_1^\dagger\right) \\
&+ \cos\left(\theta + \frac{\pi}{4}\right) \cosh \xi \left(B_2 + B_2^\dagger\right) \\
&- \cos\left(\theta - \frac{\pi}{4}\right) \sinh \xi \left(B_2^\dagger e^{2i\phi} + B_2 e^{-2i\phi}\right) \\
&- \cos\left(\theta + \frac{\pi}{4}\right) \sinh \xi \left(B_1^\dagger e^{2i\phi} + B_1 e^{-2i\phi}\right) .
\end{aligned} \tag{17.422}$$

Thus, the expectation value vanishes

$$\langle \xi, \phi | X_\theta | \xi, \phi \rangle = 0 , \tag{17.423}$$

and the variance $\langle \xi, \phi | (\Delta X_\theta)^2 | \xi, \phi \rangle = \langle \xi, \phi | X_\theta^2 | \xi, \phi \rangle$ is given by

$$\begin{aligned}
& \langle \xi, \phi | (\Delta X_\theta)^2 | \xi, \phi \rangle \\
&= \left(\cos\left(\theta - \frac{\pi}{4}\right) \cosh \xi - \cos\left(\theta + \frac{\pi}{4}\right) \sinh \xi e^{-2i\phi} \right) \\
&\times \left(\cos\left(\theta - \frac{\pi}{4}\right) \cosh \xi - \cos\left(\theta + \frac{\pi}{4}\right) \sinh \xi e^{2i\phi} \right) \\
&+ \left(\cos\left(\theta + \frac{\pi}{4}\right) \cosh \xi - \cos\left(\theta - \frac{\pi}{4}\right) \sinh \xi e^{-2i\phi} \right) \\
&\times \left(\cos\left(\theta + \frac{\pi}{4}\right) \cosh \xi - \cos\left(\theta - \frac{\pi}{4}\right) \sinh \xi e^{2i\phi} \right) .
\end{aligned} \tag{17.424}$$

With some algebra this can be simplified

$$\langle \xi, \phi | (\Delta X_\theta)^2 | \xi, \phi \rangle = \cosh(2\xi) - \sinh(2\xi) \cos(2\theta) \cos(2\phi) . \tag{17.425}$$

Similarly, the operator P_θ can be expressed as

$$\begin{aligned}
P_\theta &= i \cos \theta \frac{B_1 - B_1^\dagger + B_2 - B_2^\dagger}{\sqrt{2}} \\
&+ i \sin \theta \frac{B_1 - B_1^\dagger - B_2 + B_2^\dagger}{\sqrt{2}} \\
&= i \cos\left(\theta - \frac{\pi}{4}\right) \left(B_1 - B_1^\dagger\right) \\
&+ i \cos\left(\theta + \frac{\pi}{4}\right) \left(B_2 - B_2^\dagger\right) .
\end{aligned} \tag{17.426}$$

Using Eqs. (17.224) and (17.225) one finds that

$$\begin{aligned}
 & S^\dagger(\xi, \phi) P_\theta S(\xi, \phi) \\
 &= i \cos\left(\theta - \frac{\pi}{4}\right) \cosh \xi \left(B_1 - B_1^\dagger\right) \\
 &+ i \cos\left(\theta + \frac{\pi}{4}\right) \cosh \xi \left(B_2 - B_2^\dagger\right) \\
 &+ i \cos\left(\theta + \frac{\pi}{4}\right) \sinh \xi \left(B_1 e^{-2i\phi} - B_1^\dagger e^{2i\phi}\right) \\
 &+ i \cos\left(\theta - \frac{\pi}{4}\right) \sinh \xi \left(B_2 e^{-2i\phi} - B_2^\dagger e^{2i\phi}\right)
 \end{aligned}$$

Thus, the expectation value vanishes

$$\langle \xi, \phi | P_\theta | \xi, \phi \rangle = 0, \quad (17.427)$$

and the variance $\langle \xi, \phi | (\Delta P_\theta)^2 | \xi, \phi \rangle = \langle \xi, \phi | P_\theta^2 | \xi, \phi \rangle$ is given by

$$\langle \xi, \phi | (\Delta P_\theta)^2 | \xi, \phi \rangle = \cosh(2\xi) + \sinh(2\xi) \cos(2\theta) \cos(2\phi). \quad (17.428)$$

Using the above results one finds that

$$\Delta X_\theta \Delta P_\theta = \sqrt{1 + \sinh^2(2\xi) (1 - \cos^2(2\theta) \cos^2(2\phi))}. \quad (17.429)$$

d) Using the notation

$$\Sigma_- = -B_1 B_2, \quad (17.430)$$

$$\Sigma_+ = B_1^\dagger B_2^\dagger, \quad (17.431)$$

the two-mode squeezing operator $S(\xi, \phi)$, which is given by Eq. (17.222), can be expressed as

$$S(\xi, \phi) = \exp[-\xi (e^{-2i\phi} \Sigma_- + e^{2i\phi} \Sigma_+)]. \quad (17.432)$$

Define the vector of operators $\Sigma = (\Sigma_x, \Sigma_y, \Sigma_z)$

$$\Sigma_x = \Sigma_+ + \Sigma_-, \quad (17.433)$$

$$\Sigma_y = -i(\Sigma_+ - \Sigma_-), \quad (17.434)$$

$$\Sigma_z = [\Sigma_+, \Sigma_-]. \quad (17.435)$$

Using the following identities

$$[\Sigma_+, \Sigma_-] = B_1 B_1^\dagger + B_2^\dagger B_2, \quad (17.436)$$

and

$$[\Sigma_\pm, [\Sigma_+, \Sigma_-]] = \mp 2\Sigma_\pm, \quad (17.437)$$

one finds that the following holds

$$[\Sigma_x, \Sigma_y] = 2i [\Sigma_+, \Sigma_-] = 2i \Sigma_z, \quad (17.438)$$

$$[\Sigma_y, \Sigma_z] = 2i (\Sigma_+ + \Sigma_-) = 2i \Sigma_x, \quad (17.439)$$

$$[\Sigma_z, \Sigma_x] = 2 (\Sigma_+ - \Sigma_-) = 2i \Sigma_y, \quad (17.440)$$

thus

$$[\Sigma_i, \Sigma_j] = 2i \varepsilon_{ijk} \Sigma_k, \quad (17.441)$$

where $i, j, k \in \{x, y, z\}$. Thus, by employing the analogy between $\Sigma = (\Sigma_x, \Sigma_y, \Sigma_z)$ and the vector of Pauli matrices together with Eq. (6.745) one finds that

$$\begin{aligned} S(\xi, \phi) &= \exp(-e^{2i\phi} \tanh \xi \Sigma_+) \\ &\quad \times \exp(-\log(\cosh \xi) \Sigma_z) \\ &\quad \times \exp(-e^{-2i\phi} \tanh \xi \Sigma_-), \end{aligned} \quad (17.442)$$

or

$$\begin{aligned} S(\xi, \phi) &= \exp(-e^{2i\phi} \tanh \xi B_1^\dagger B_2^\dagger) \\ &\quad \times \exp(-\log(\cosh \xi) (B_1 B_1^\dagger + B_2^\dagger B_2)) \\ &\quad \times \exp(e^{-2i\phi} \tanh \xi B_1 B_2). \end{aligned} \quad (17.443)$$

e) With the help of Eq. (17.235) and the relations

$$B_1 B_2 |0, 0\rangle = 0, \quad (17.444)$$

$$(B_1 B_1^\dagger + B_2^\dagger B_2) |0, 0\rangle = |0, 0\rangle, \quad (17.445)$$

the state $|\xi, \phi\rangle = S(\xi, \phi) |0, 0\rangle$ can be easily expanded in the basis of number states $|n_1, n_2\rangle_{\text{B}}$

$$\begin{aligned} |\xi, \phi\rangle &= \frac{\exp(-e^{2i\phi} \tanh \xi B_1^\dagger B_2^\dagger)}{\cosh \xi} |0, 0\rangle \\ &= \frac{1}{\cosh \xi} \sum_{n=0}^{\infty} \frac{-e^{2ni\phi} \tanh^n \xi (B_1^\dagger B_2^\dagger)^n}{n!} |0, 0\rangle \\ &= -\frac{1}{\cosh \xi} \sum_{n=0}^{\infty} e^{2ni\phi} \tanh^n \xi |n, n\rangle_{\text{B}}, \end{aligned} \quad (17.446)$$

where

$$|n_1, n_2\rangle_{\text{B}} = \frac{(B_1^\dagger)^{n_1} (B_2^\dagger)^{n_2}}{\sqrt{n_1!} \sqrt{n_2!}} |0, 0\rangle, \quad (17.447)$$

and where $|0, 0\rangle$ is the ground state of \mathcal{H}_0 . With the help of Eq. (17.399) one finds for the case $|\psi_{\text{I}}(0)\rangle = |0, 0\rangle$ that

$$\begin{aligned} |\psi(t)\rangle &= e^{-i\mathcal{H}_0 t/\hbar} |\psi_{\text{I}}(t)\rangle \\ &= e^{-i\mathcal{H}_0 t/\hbar} S(\xi, \phi) |0, 0\rangle \\ &= e^{-i\mathcal{H}_0 t/\hbar} |\xi, \phi\rangle \\ &= -e^{-i\omega_0 t} [(1+\eta)B_1^\dagger B_1 + (1-\eta)B_2^\dagger B_2] \\ &\quad \times \frac{\sum_{n=0}^{\infty} e^{2ni\phi} \tanh^n \xi}{\cosh \xi} |n, n\rangle_{\text{B}}, \end{aligned} \quad (17.448)$$

thus

$$|\psi(t)\rangle = -\frac{\sum_{n=0}^{\infty} e^{2ni(\phi - \omega_0 t)} \tanh^n \xi}{\cosh \xi} |n, n\rangle_{\text{B}}, \quad (17.449)$$

or

$$e^{-i\mathcal{H}_0 t/\hbar} |\xi, \phi\rangle = |\xi, \phi - \omega_0 t\rangle. \quad (17.450)$$

Let O_1 be a single mode operator, which operates on the space of the first mode (corresponding to the operators B_1 and B_1^\dagger). The expectation value $\langle O_1 \rangle$ with respect to the state $e^{-i\mathcal{H}_0 t/\hbar} |\xi, \phi\rangle$ is found using Eq. (17.446)

$$\begin{aligned} \langle O_1 \rangle &= \frac{1}{\cosh^2 \xi} \sum_{n'=0}^{\infty} \tanh^{2n} \xi \langle n' | O_1 | n' \rangle \\ &= (1 - \tanh^2 \xi) \sum_{n'=0}^{\infty} \tanh^{2n} \xi \langle n' | O_1 | n' \rangle, \end{aligned} \quad (17.451)$$

or

$$\langle O_1 \rangle = \text{Tr}(\rho_{\text{eff}} O_1),$$

where ρ_{eff} , which is given by

$$\rho_{\text{eff}} = (1 - \tanh^2 \xi) \sum_{n''=0}^{\infty} (\tanh \xi)^{2n''} |n''\rangle \langle n''| ,$$

represents an effective density operator. For comparison, the density operator in thermal equilibrium is given by [see Eq. (8.262)]

$$\rho = (1 - e^{-\beta \hbar \omega_1}) \sum_{n''=0}^{\infty} e^{-n'' \beta \hbar \omega_1} |n''\rangle \langle n''| ,$$

where $\beta = 1/(k_{\text{B}}T)$ and $\omega_1 = \omega_0(1 + \eta)$ is the angular frequency of the first mode, thus the single mode expectation value is the same as the thermal expectation value with effective temperature T_{eff} given by

$$T_{\text{eff}} = \frac{\hbar \omega_1}{2k_{\text{B}} \log(\coth \xi)} . \quad (17.452)$$

Alternatively, this result can be expressed in terms of the effective occupation factor n_{eff} , which is related to T_{eff} by the relation [see Eq. (8.283)]

$$1 + 2n_{\text{eff}} = \coth \frac{\hbar \omega_1}{2k_{\text{B}} T_{\text{eff}}} , \quad (17.453)$$

and it is given by

$$n_{\text{eff}} = \frac{\coth(\log(\coth \xi)) - 1}{2} = \sinh^2 \xi . \quad (17.454)$$

f) The following holds

$$\frac{A_1^2 - A_1^{\dagger 2} - A_2^2 + A_2^{\dagger 2}}{2} = B_1 B_2 - B_1^{\dagger} B_2^{\dagger} ,$$

and thus the operator $S(\xi, \phi)$ [see Eq. (17.222)] for the case $\phi = 0$ is given by [see Eqs. (17.419) and (17.420)]

$$\begin{aligned} S(\xi, 0) &= \exp \left[\xi (B_1 B_2 - B_1^{\dagger} B_2^{\dagger}) \right] \\ &= \exp \left[\frac{\xi}{2} (A_1^2 - A_1^{\dagger 2} - A_2^2 + A_2^{\dagger 2}) \right] \\ &= \exp \left[\frac{\xi (A_1^2 - A_1^{\dagger 2})}{2} \right] \exp \left[-\frac{\xi (A_2^2 - A_2^{\dagger 2})}{2} \right] . \end{aligned} \quad (17.455)$$

g) The desired expression (17.238) is obtained with the help of Eqs. (17.237) and (6.256) [see also Eq. (6.253)].

h) With the help of Eqs. (5.11), (5.131), (17.229) and (17.238) one finds that

$$\begin{aligned}\psi_S(X'_1, X'_2) &= \langle X'_1, X'_2 | \xi, 0 \rangle \\ &= \frac{1}{\pi^{1/2}} \exp\left(-\frac{e^{2\xi} X'^2_1 + e^{-2\xi} X'^2_2}{2}\right),\end{aligned}$$

and thus [see Eq. (17.239)]

$$\psi_S(X'_+, X'_-) = \frac{1}{\pi^{1/2}} \exp\left(-\frac{e^{2\xi} (X'_+ + X'_-)^2 + e^{-2\xi} (X'_+ - X'_-)^2}{4}\right). \quad (17.456)$$

With the help of the above result (17.456) one finds that the probability distribution function $P_x(X'_+, X'_-)$ is a joint normal distribution given by

$$\begin{aligned}P_x(X'_+, X'_-) &= |\psi_S(X'_+, X'_-)|^2 \\ &= \frac{1}{\pi} \exp\left(-\frac{e^{2\xi} (X'_+ + X'_-)^2 + e^{-2\xi} (X'_+ - X'_-)^2}{2}\right) \\ &= \frac{e^{-\frac{1}{2(1-\rho_x^2)} \left[\left(\frac{X'_+}{\sigma_x}\right)^2 + \left(\frac{X'_-}{\sigma_x}\right)^2 - \frac{2\rho_x X'_+ X'_-}{\sigma_x^2} \right]}}{2\pi\sigma_x^2 \sqrt{1-\rho_x^2}},\end{aligned} \quad (17.457)$$

where

$$\sigma_x = \sqrt{\frac{\cosh(2\xi)}{2}}, \quad (17.458)$$

and

$$\rho_x = -\tanh(2\xi). \quad (17.459)$$

The distribution function $P_x(X'_+, X'_-)$ allows calculating the conditional probability distribution function $P_x(X'_+|X'_-)$ [see Eq. (5.149)]

$$\begin{aligned}P_x(X'_+|X'_-) &= \frac{P_x(X'_+, X'_-)}{\int_{-\infty}^{\infty} P_x(X'_+, X'_-) dX'_+} \\ &= \frac{1}{\sqrt{2\pi(1-\rho_x^2)}\sigma_x^2} e^{-\frac{(X'_+ - \rho_x X'_-)^2}{2(1-\rho_x^2)\sigma_x^2}},\end{aligned} \quad (17.460)$$

which is found to be a normal distribution with

$$\langle X'_+|X'_- \rangle = \rho_x X'_- = -X'_- \tanh(2\xi), \quad (17.461)$$

and

$$\langle (X'_+ - \langle X'_+ | X'_- \rangle)^2 | X'_- \rangle = (1 - \rho_x^2) \sigma_x^2 = \frac{1}{2 \cosh(2\xi)}. \quad (17.462)$$

18. Superconductivity

In this chapter two models are discussed, the London's model, in which a macroscopic wavefunction is introduced to describe the state of a superconductor, and the model by Bardeen, Cooper and Schrieffer (BCS), which provides an insight on the underlying microscopic mechanisms that are responsible for superconductivity.

18.1 Macroscopic Wavefunction

In this section the London's equations are derived from the assumption that the state of a superconductor can be describe using a macroscopic wavefunction.

18.1.1 Single Particle in Electromagnetic Field

Consider a single particle having charge q and mass m in electromagnetic field characterized by the scalar potential φ and the vector potential \mathbf{A} . The electric field \mathbf{E} and the magnetic field \mathbf{B} are given by (in Gaussian units) [see Eqs. (1.41) and (1.42)]

$$\mathbf{E} = -\nabla\varphi - \frac{1}{c} \frac{\partial \mathbf{A}}{\partial t}, \quad (18.1)$$

and

$$\mathbf{B} = \nabla \times \mathbf{A}, \quad (18.2)$$

where $c = 2.99 \times 10^8 \text{ m s}^{-1}$ is the speed of light in vacuum. Let $\mathbf{r} = (x, y, z)$ be the position vector of the particle in Cartesian coordinates. The variable vector canonically conjugate to the position vector \mathbf{r} is given by [see Eq. (1.61)]

$$\mathbf{p} = m\dot{\mathbf{r}} + \frac{q}{c} \mathbf{A}. \quad (18.3)$$

The classical equation of motion is given by [see Eq. (1.60)]

$$m\ddot{\mathbf{r}} = q \left(\mathbf{E} + \frac{1}{c} \dot{\mathbf{r}} \times \mathbf{B} \right). \quad (18.4)$$

The Schrödinger Equation. The Hamiltonian of the system is given by [see Eq. (1.62)]

$$\mathcal{H} = \frac{(\mathbf{p} - \frac{q}{c}\mathbf{A})^2}{2m} + q\varphi . \quad (18.5)$$

The Schrödinger equation for the wavefunction $\psi(\mathbf{r}', t')$ is given by [see Eq. (4.268)]

$$i\hbar \frac{d\psi}{dt} = \frac{1}{2m} \left(-i\hbar\nabla - \frac{q}{c}\mathbf{A} \right)^2 \psi + q\varphi\psi . \quad (18.6)$$

The continuity Equation. The continuity equation expresses the probability conservation law [see Eq. (4.81)]

$$\frac{d\rho}{dt} + \nabla \cdot \mathbf{J} = 0 , \quad (18.7)$$

where

$$\rho = \psi\psi^* \quad (18.8)$$

is the probability distribution function and

$$\mathbf{J} = \frac{\hbar}{m} \text{Im} (\psi^* \nabla \psi) - \frac{q\rho}{mc} \mathbf{A} \quad (18.9)$$

is the current density [see Eq. (4.274)]. For a wavefunction having the form

$$\psi = \rho^{1/2} e^{i\theta} , \quad (18.10)$$

where θ is real, one has [see Eq. (6.608)]

$$\mathbf{J} = \frac{\rho}{m} \left(\hbar \nabla \theta - \frac{q}{c} \mathbf{A} \right) . \quad (18.11)$$

Gauge Invariance. Consider the following gauge transformation [see Eqs. (12.49) and (12.50)]

$$\mathbf{A} \rightarrow \tilde{\mathbf{A}} = \mathbf{A} + \nabla\chi , \quad (18.12)$$

$$\varphi \rightarrow \tilde{\varphi} = \varphi , \quad (18.13)$$

where $\chi = \chi(\mathbf{r})$ is an arbitrary smooth and continuous function of \mathbf{r} , which is assumed to be time independent. This transformation leaves \mathbf{E} and \mathbf{B} unchanged [see Eqs. (12.1) and (12.2)], however, the wavefunction is transformed according to the following rule. Given that the wavefunction $\psi(\mathbf{r}', t')$ solves the Schrödinger equation with vector \mathbf{A} and scalar φ potentials, the transformed Schrödinger equation with vector $\tilde{\mathbf{A}} = \mathbf{A} + \nabla\chi$ and scalar $\tilde{\varphi} = \varphi$ potentials is solved by the transformed wavefunction $\tilde{\psi}(\mathbf{r}', t')$, which is given by [see Eq. (12.53)]

$$\tilde{\psi}(\mathbf{r}', t') = \exp\left(\frac{iq\chi(\mathbf{r}')}{\hbar c}\right) \psi(\mathbf{r}', t') . \quad (18.14)$$

18.1.2 The Macroscopic Quantum Model

The macroscopic quantum model is based on the hypothesis that some properties of a superconducting media can be described by a single wavefunction $\psi_s(\mathbf{r}', t')$. It is assumed that the local density of superconducting charge carriers n_s^* is related to the wavefunction by

$$n_s^* = |\psi_s(\mathbf{r}', t')|^2 . \quad (18.15)$$

In the presence of an electromagnetic field the time evolution of $\psi_s(\mathbf{r}', t')$ is governed by the Schrödinger equation [see Eq. (18.6)]

$$i\hbar \frac{d\psi_s}{dt} = \frac{1}{2m_s^*} \left(-i\hbar \nabla - \frac{q_s^*}{c} \mathbf{A} \right)^2 \psi_s + q_s^* \varphi \psi_s . \quad (18.16)$$

where m_s^* and q_s^* are the mass and charge respectively of a superconducting charge carrier. Furthermore, it is assumed that the current density carried by a superconductor having a macroscopic wavefunction given by [see Eq. (18.10)]

$$\psi_s(\mathbf{r}', t') = \sqrt{n_s^*(\mathbf{r}', t')} e^{i\theta(\mathbf{r}', t')} , \quad (18.17)$$

is given by

$$\mathbf{J}_s = \frac{q_s^* n_s^*(\mathbf{r}', t')}{m_s^*} \left(\hbar \nabla \theta - \frac{q_s^*}{c} \mathbf{A} \right) . \quad (18.18)$$

Note that while \mathbf{J} in Eq. (18.11) represents probability current density, \mathbf{J}_s in a superconductor represents charge current density.

18.1.3 London Equations

London equations can be derived from the macroscopic quantum model by assuming that the superconducting charge carriers density n_s^* is constant.

2nd London Equation. By taking the curl of Eq. (18.18) and employing Eq. (18.2) one obtains the second London equation, which reads

$$\nabla \times \mathbf{J}_s = -\frac{q_s^{*2} n_s^*}{m_s^* c} \mathbf{B} . \quad (18.19)$$

In the presence of charge density ρ and current density \mathbf{J} the Maxwell's equations (14.1), (14.2), (14.3) and (14.4) become

$$\nabla \times \mathbf{B} = \frac{4\pi}{c} \mathbf{J} + \frac{1}{c} \frac{\partial \mathbf{E}}{\partial t} , \quad (18.20)$$

$$\nabla \times \mathbf{E} = -\frac{1}{c} \frac{\partial \mathbf{B}}{\partial t} , \quad (18.21)$$

$$\nabla \cdot \mathbf{E} = 4\pi \rho , \quad (18.22)$$

$$\nabla \cdot \mathbf{B} = 0 . \quad (18.23)$$

Taking the curl of Eq. (18.20) and employing Eqs. (18.19), (18.21) and (18.23) together with the general vector identity

$$\nabla \times \nabla \times \mathbf{B} = \nabla (\nabla \cdot \mathbf{B}) - \nabla^2 \mathbf{B} \quad (18.24)$$

lead to

$$\nabla^2 \mathbf{B} = \frac{1}{\lambda_L^2} \mathbf{B} + \frac{1}{c^2} \frac{\partial^2 \mathbf{B}}{\partial t^2}, \quad (18.25)$$

where

$$\lambda_L = \sqrt{\frac{m_s^* c^2}{4\pi n_s^* q_s^{*2}}} \quad (18.26)$$

is the London penetration depth in Gaussian units ($\lambda_L = \sqrt{m_s^* / \mu_0 n_s^* q_s^{*2}}$ in SI units). In terms of the superconducting plasma frequency $\omega_{p,s}$, which is given by

$$\omega_{p,s}^2 = \frac{4\pi n_s^* q_s^{*2}}{m_s^*}, \quad (18.27)$$

the London penetration depth can be expressed as

$$\lambda_L = \frac{c}{\omega_{p,s}}. \quad (18.28)$$

For time independent \mathbf{B} the solution of Eq. (18.25) yields an exponential decay of \mathbf{B} with characteristic decay length given by the London penetration depth λ_L . Thus, except of a region having characteristic width λ_L near the surfaces the magnetic field inside a superconductor vanishes (even in the presence of an externally applied magnetic field). This expulsion of a magnetic field from a superconductor, which is called the Meissner effect, represents the perfect diamagnetism of superconductors. As can be seen from Eq. (18.20), in the absence of time dependent electric field the expulsion of a magnetic field also implies that the supercurrent density \mathbf{J}_s also vanishes deep inside a superconductor.

1st London Equation. When the superconducting density of charge carriers n_s^* is assumed to be a constant Eq. (18.16) becomes [see Eq. (18.17)]

$$-\hbar \frac{d\theta}{dt} = \frac{1}{2m_s^*} \left(\hbar \nabla \theta - \frac{q_s^*}{c} \mathbf{A} \right)^2 + q_s^* \varphi, \quad (18.29)$$

or [see Eq. (18.18)]

$$-\hbar \frac{d\theta}{dt} = \frac{m_s^*}{2q_s^{*2} n_s^{*2}} \mathbf{J}_s^2 + q_s^* \varphi. \quad (18.30)$$

Applying ∇ to the above leads to

$$-\hbar \frac{d\nabla\theta}{dt} = \frac{m_s^*}{2q_s^{*2}n_s^{*2}} \nabla \mathbf{J}_s^2 + q_s^* \nabla \varphi . \quad (18.31)$$

Taking the time derivative of Eq. (18.18) and employing Eq. (18.1) together with the last result yield the first London equation

$$\frac{m_s^*}{q_s^{*2}n_s^*} \left(\frac{\partial \mathbf{J}_s}{\partial t} + \frac{1}{2q_s^*n_s^*} \nabla \mathbf{J}_s^2 \right) = \mathbf{E} . \quad (18.32)$$

Typically in superconductors the electric field \mathbf{E} on the right hand side of Eq. (18.32) can be neglected in comparison with the term proportional to $\nabla \mathbf{J}_s^2$ on the left hand side of Eq. (18.32). The factor $\nabla \mathbf{J}_s^2$ can be estimated by the relation $|\nabla \mathbf{J}_s^2| \simeq 2|\mathbf{J}_s|^2/l_0$, where l_0 is a length scale that characterizes the spacial variations of the current density \mathbf{J}_s . Moreover, the ratio $|\mathbf{J}_s|/l_0$ can be estimated from the second London equation (18.19)

$$\frac{|\mathbf{J}_s|}{l_0} \simeq \frac{q_s^{*2}n_s^*}{m_s^*c} |\mathbf{B}| . \quad (18.33)$$

Combining these results allows estimating the term proportional to $\nabla \mathbf{J}_s^2$ on the left hand side of Eq. (18.32)

$$\frac{m_s^*}{q_s^{*2}n_s^*} \frac{1}{2q_s^*n_s^*} |\nabla \mathbf{J}_s^2| \simeq \frac{1}{c} |\mathbf{v}_s| |\mathbf{B}| , \quad (18.34)$$

where [see Eq. (18.254)]

$$\mathbf{v}_s = \frac{\mathbf{J}_s}{q_s^*n_s^*} \quad (18.35)$$

is the velocity of superconducting charge carriers. In view of the classical equation of motion (18.4) the above estimate shows that the ratio between $|\mathbf{E}|$ and the term proportional to $\nabla \mathbf{J}_s^2$ in Eq. (18.32) represents the ratio between electric and magnetic forces acting on the superconducting charges. Typically in metals electric forces are strongly suppressed due to screening, and consequently can be neglected in comparison with magnetic forces. Neglecting the \mathbf{E} term in Eq. (18.32) leads to

$$\frac{\partial \mathbf{J}_s}{\partial t} + \frac{1}{2q_s^*n_s^*} \nabla \mathbf{J}_s^2 = 0 . \quad (18.36)$$

Homogeneous solutions (i.e. position independent solutions) of the first London equation (18.32) satisfy

$$\frac{m_s^*}{q_s^{*2}n_s^*} \frac{\partial \mathbf{J}_s}{\partial t} = \mathbf{E} , \quad (18.37)$$

or

$$m_s^* \frac{\partial \mathbf{v}_s}{\partial t} = q_s^* \mathbf{E}. \quad (18.38)$$

The above relation (18.38) is analogous to the classical equation of motion given by Eq. (18.4) for the case of vanishing magnetic field. The absence of any damping term in Eq. (18.38) represents the nullification of resistance in superconductors.

Flux Quantization. Consider a close curve \mathcal{C} inside a superconductor. Integrating Eq. (18.18), which is given by

$$\mathbf{J}_s = \frac{q_s^* n_s^*}{m_s^*} \left(\hbar \nabla \theta - \frac{q_s^*}{c} \mathbf{A} \right), \quad (18.39)$$

along the curve yields

$$\oint_{\mathcal{C}} \mathbf{dr} \cdot \mathbf{J}_s = \frac{q_s^* n_s^*}{m_s^*} \left(\hbar \oint_{\mathcal{C}} \mathbf{dr} \cdot \nabla \theta - \frac{q_s^*}{c} \oint_{\mathcal{C}} \mathbf{dr} \cdot \mathbf{A} \right). \quad (18.40)$$

The assumption that the superconducting wavefunction $\psi_s = \sqrt{n_s^*} e^{i\theta}$ is continuous implies that $\oint_{\mathcal{C}} \mathbf{dr} \cdot \nabla \theta = 2n\pi$, where n is integer. The integral over \mathbf{A} can be calculated using Stokes' theorem [see Eqs. (12.2) and (12.47)]

$$\oint_{\mathcal{C}} \mathbf{dr} \cdot \mathbf{A} = \phi_{\mathcal{C}}, \quad (18.41)$$

where $\phi_{\mathcal{C}} = \int \mathbf{ds} \cdot \mathbf{B}$ is the magnetic flux threaded through the area enclosed by the closed path \mathcal{C} . With these results Eq. (18.40) becomes

$$\oint_{\mathcal{C}} \mathbf{dr} \cdot \mathbf{J}_s = \frac{\hbar q_s^* n_s^*}{m_s^*} \left(n - \frac{\phi_{\mathcal{C}}}{\phi_s} \right), \quad (18.42)$$

where

$$\phi_s = \frac{\hbar c}{q_s^*} \quad (18.43)$$

is the so called superconducting flux quantum (in Gaussian units). As will be shown below, the elementary superconducting charge carrier is a pair of electrons, i.e. $q_s^* = 2e$, and consequently Eq. (18.43) becomes

$$\phi_s = \frac{\hbar c}{2e}. \quad (18.44)$$

As was shown above, the second London equation implies that the super-current density \mathbf{J}_s vanishes deep inside a superconductor. Consider a close curve \mathcal{C} inside a superconductor and assume that the distance between any

point on \mathcal{C} and the nearest surface is much larger than the London penetration depth λ_L . For such a curve the left hand side of Eq. (18.42) vanishes, and consequently

$$\phi_{\mathcal{C}} = n\phi_s, \quad (18.45)$$

i.e. the magnetic flux is quantized in units of the superconducting flux quantum.

18.2 The Josephson Effect

A Josephson junction is formed between two superconductors that are weakly coupled to each other. Electrons can flow between the two superconducting ports by crossing a barrier. In this section the first and second Josephson relations are derived based on a simple two-state model.

18.2.1 Two-State Model

The state vector of the junction $|\phi\rangle$ is expressed in terms of basis states $|\phi_L\rangle$ and $|\phi_R\rangle$ as

$$|\phi\rangle = n_L^{1/2} e^{i\theta_L} |\phi_L\rangle + n_R^{1/2} e^{i\theta_R} |\phi_R\rangle, \quad (18.46)$$

where $n_{L,R}$ and $\theta_{L,R}$ are all real, and where the normalized states $|\phi_L\rangle$ and $|\phi_R\rangle$, which represent, respectively, the left and right ports of the junction, are orthogonal to each other, i.e. $\langle\phi_L|\phi_R\rangle = 0$. The Hamiltonian of the system is taken to be given by

$$\begin{aligned} \mathcal{H} = & E_L |\phi_L\rangle \langle\phi_L| + E_R |\phi_R\rangle \langle\phi_R| \\ & + \hbar g e^{i\phi} |\phi_L\rangle \langle\phi_R| + \hbar g e^{-i\phi} |\phi_R\rangle \langle\phi_L|, \end{aligned} \quad (18.47)$$

where $E_{L,R}$, g and ϕ are all real (to ensure that \mathcal{H} is Hermitian). The energy expectation value is given by

$$\langle\phi|\mathcal{H}|\phi\rangle = n_L E_L + n_R E_R + \frac{\phi_s}{2\pi} I_c \cos \Theta,$$

where $\phi_s = hc/2e$ is the flux quantum [see Eq. (18.44)], the so-called critical current I_c is given by

$$I_c = \frac{4e\sqrt{n_L n_R} g}{c}, \quad (18.48)$$

and the relative phase Θ is given by

$$\Theta = \theta_L - \theta_R - \phi . \quad (18.49)$$

The Schrödinger equation, which reads

$$i\hbar \frac{d|\phi\rangle}{dt} = \mathcal{H}|\phi\rangle , \quad (18.50)$$

yields

$$i\hbar \frac{d}{dt} \begin{pmatrix} n_L^{1/2} e^{i\theta_L} \\ n_R^{1/2} e^{i\theta_R} \end{pmatrix} = \begin{pmatrix} E_L & \hbar g e^{i\phi} \\ \hbar g e^{-i\phi} & E_R \end{pmatrix} \begin{pmatrix} n_L^{1/2} e^{i\theta_L} \\ n_R^{1/2} e^{i\theta_R} \end{pmatrix} , \quad (18.51)$$

or

$$\frac{dn_L^{1/2}}{dt} + in_L^{1/2} \frac{d\theta_L}{dt} = -i \left(\frac{E_L}{\hbar} n_L^{1/2} + gn_R^{1/2} e^{-i\Theta} \right) , \quad (18.52)$$

$$\frac{dn_R^{1/2}}{dt} + in_R^{1/2} \frac{d\theta_R}{dt} = -i \left(\frac{E_R}{\hbar} n_R^{1/2} + gn_L^{1/2} e^{i\Theta} \right) , \quad (18.53)$$

or

$$\frac{dn_L}{dt} + 2in_L \left(\frac{d\theta_L}{dt} + \frac{E_L}{\hbar} \right) = -i \frac{cI_c}{2e} e^{-i\Theta} , \quad (18.54)$$

$$\frac{dn_R}{dt} + 2in_R \left(\frac{d\theta_R}{dt} + \frac{E_R}{\hbar} \right) = -i \frac{cI_c}{2e} e^{i\Theta} . \quad (18.55)$$

18.2.2 The First Josephson Relation

The real parts of Eqs. (18.54) and (18.55) yields the first Josephson relation

$$I = I_c \sin \Theta , \quad (18.56)$$

where I , which is given by

$$I = \frac{2e}{c} \frac{dn_R}{dt} = -\frac{2e}{c} \frac{dn_L}{dt} , \quad (18.57)$$

is the current through the junction.

18.2.3 The Second Josephson Relation

When both ports are made of the same superconducting material it is common to assume that $n_L = n_R \equiv n_s$. By subtracting the imaginary part of Eq. (18.54) from the imaginary part of Eq. (18.55) one obtains the second Josephson relation

$$\frac{d\Theta}{dt} = \frac{2eV}{\hbar} , \quad (18.58)$$

where V , which is given by

$$V = \frac{E_R - E_L}{2e} , \quad (18.59)$$

is the voltage across the junction.

18.2.4 The Energy of a Josephson Junction

Let $I(t)$ and $V(t)$ be the current through and voltage across a Josephson junction, respectively, at time t . The energy U_J of the junction can be evaluated by calculating the work done by the source

$$U_J = \int^t dt' I(t') V(t') . \quad (18.60)$$

With the help of the first (18.56) and second (18.58) Josephson relations this becomes

$$U_J = \frac{\hbar I_c}{2e} \int^{\Theta} d\Theta' \sin \Theta' , \quad (18.61)$$

thus up to a constant U_J is given by

$$U_J = -E_J \cos \Theta , \quad (18.62)$$

where

$$E_J = \frac{\hbar I_c}{2e} = \frac{\phi_s I_c}{2\pi c} . \quad (18.63)$$

The energy U_J (18.62) can be expressed as [compare with Eq. (18.417) below]

$$U_J = -E_J \sqrt{1 - \left(\frac{I}{I_c}\right)^2} . \quad (18.64)$$

To second order in I this becomes [compare with Eq. (18.418) below]

$$U_J = -E_J + \frac{L_J I^2}{2} + O(I^4) , \quad (18.65)$$

where

$$L_J = \frac{\phi_s}{2\pi c I_c} \quad (18.66)$$

is the so-called Josephson inductance. Note, however, that an inductor-like behavior of a Josephson junction is expected only when $I \ll I_c$.

18.2.5 Gauge Invariant Phase

In terms of the superconducting flux quantum ϕ_s [see Eq. (18.44)] Eq. (18.39) can be rewritten as

$$\mathbf{J}_s = \frac{q_s^* n_s^* \hbar}{m_s^*} \nabla \theta_{\text{GI}} , \quad (18.67)$$

where

$$\nabla\theta_{\text{GI}} = \nabla\theta - \frac{2\pi}{\phi_s} \mathbf{A} . \quad (18.68)$$

The phase factor θ_{GI} is commonly called the gauge invariant phase.

Consider an integral over \mathbf{J}_s (18.67) along a path going through a Josephson junction from point \mathbf{r}_1 on the interface between the first superconductor and the barrier to point \mathbf{r}_2 on the interface between the second superconductor and the barrier. The phase difference Θ is obtained by integrating $\nabla\theta_{\text{GI}}$

$$\Theta = \int_{\mathbf{r}_1}^{\mathbf{r}_2} d\mathbf{r} \cdot \nabla\theta_{\text{GI}} = \theta(\mathbf{r}_2) - \theta(\mathbf{r}_1) - \frac{2\pi}{\phi_s} \int_{\mathbf{r}_1}^{\mathbf{r}_2} d\mathbf{r} \cdot \mathbf{A} . \quad (18.69)$$

18.3 RF SQUID

A radio frequency (RF) superconducting quantum interference device (SQUID) is made of a superconducting loop interrupted by a Josephson junction (see Fig. 18.1). Consider a close curve \mathcal{C} going around the loop. The requirement that the phase θ of the macroscopic wavefunction is continuous reads

$$2n\pi = \oint_{\mathcal{C}} d\mathbf{r} \cdot \nabla\theta , \quad (18.70)$$

where n is integer. The section of the close curve \mathcal{C} inside the superconductor is denoted by \mathcal{C}^- and the integral through the junction is denoted as an integral from point \mathbf{r}_1 to point \mathbf{r}_2 . With the help of Eq. (18.39) the above condition becomes

$$2n\pi = \frac{m_s^*}{q_s^* n_s^* \hbar} \int_{\mathbf{r}_1}^{\mathbf{r}_2} d\mathbf{r} \cdot \mathbf{J}_s + \frac{m_s^*}{q_s^* n_s^* \hbar} \int_{\mathcal{C}^-} d\mathbf{r} \cdot \mathbf{J}_s + \frac{2\pi}{\phi_s} \int_{\mathcal{C}} d\mathbf{r} \cdot \mathbf{A} . \quad (18.71)$$

Consider the case where the curve is chosen such that the supercurrent density \mathbf{J}_s vanishes everywhere on the curve \mathcal{C}^- (i.e. inside the superconductor the distance between any point on \mathcal{C}^- and the nearest surface is much larger than the London penetration depth λ_L). For this case Eq. (18.71) becomes

$$2n\pi = \Theta + \frac{2\pi\phi}{\phi_s} , \quad (18.72)$$

where

$$\Theta = \frac{m_s^*}{q_s^* n_s^* \hbar} \int_{\mathbf{r}_1}^{\mathbf{r}_2} d\mathbf{r} \cdot \mathbf{J}_s = \int_{\mathbf{r}_1}^{\mathbf{r}_2} d\mathbf{r} \cdot \nabla\theta_{\text{GI}} \quad (18.73)$$

is the gauge invariant phase difference across the junction [see Eqs. (18.67) and (18.69)] and where

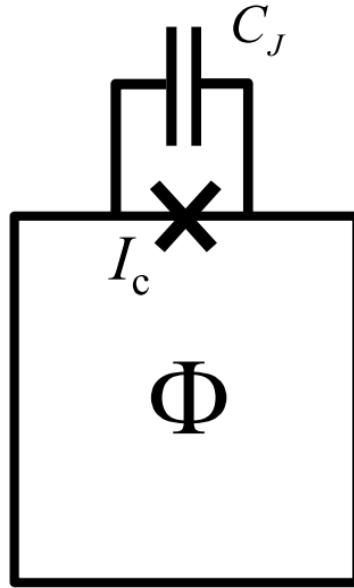

Fig. 18.1. RF SQUID is made of a superconducting loop interrupted by a Josephson junction.

$$\phi = \oint_{\mathcal{C}} \mathbf{dr} \cdot \mathbf{A} \quad (18.74)$$

is the magnetic flux threaded through the area enclosed by the closed path \mathcal{C} [see Eq. (18.41)].

The junction's critical current is labeled by I_c . It is assumed that the junction has capacitance, which is denoted by C_J . Consider the case where a magnetic flux that is denoted by ϕ_e is externally applied. The total magnetic flux ϕ threading the loop is given by

$$\phi = \phi_e + \Lambda I_s, \quad (18.75)$$

where I_s is the circulating current flowing in the loop and Λ is the self inductance of the loop.

18.3.1 Lagrangian

The Lagrangian of the system [see Eq. (1.16)] can be expressed as a function of the dimensionless flux coordinate Φ , which is defined by

$$\Phi = \frac{2\pi\phi}{\phi_s}, \quad (18.76)$$

and its time derivative $\dot{\Phi}$. According to Faraday's law of induction the voltage across the capacitor (in Gaussian units) is

$$V = -\frac{\dot{\phi}}{c}, \quad (18.77)$$

and therefore the kinetic energy of the system T is the capacitance energy

$$T = \frac{C_J \dot{\phi}^2}{2c^2} = \frac{C_J \phi_s^2 \dot{\Phi}^2}{8\pi^2 c^2}. \quad (18.78)$$

The potential energy U has two contributions, the inductive energy (in Gaussian units)

$$\frac{\Lambda I_s^2}{2c} = \frac{(\phi - \phi_e)^2}{2\Lambda c} = \frac{\phi_s^2 (\Phi - \Phi_e)^2}{8\pi^2 \Lambda c}, \quad (18.79)$$

where

$$\Phi_e = \frac{2\pi\phi_e}{\phi_s} \quad (18.80)$$

is the normalized external flux, and the Josephson energy U_J [see Eqs. (18.62) and (18.72)]

$$U_J = -\frac{\phi_s I_c}{2\pi c} \cos \Phi. \quad (18.81)$$

Thus the Lagrangian $\mathcal{L} = T - U$ is given by

$$\mathcal{L} = \frac{C_J \phi_s^2 \dot{\Phi}^2}{8\pi^2 c^2} - \frac{\phi_s^2 (\Phi - \Phi_e)^2}{8\pi^2 c \Lambda} + \frac{\phi_s I_c}{2\pi c} \cos \Phi, \quad (18.82)$$

or in a dimensionless form by

$$\mathcal{L} = E_0 \left(\frac{\Lambda}{L_J} \frac{\dot{\Phi}^2}{\omega_p^2} - u(\Phi; \Phi_e) \right), \quad (18.83)$$

where the energy constant E_0 is given by

$$E_0 = \frac{\phi_s^2}{8\pi^2 \Lambda c}, \quad (18.84)$$

the junction's plasma frequency ω_p is given by

$$\omega_p = \sqrt{\frac{c}{L_J C_J}} = \sqrt{\frac{2ecI_c}{\hbar C_J}}, \quad (18.85)$$

where $L_J = \phi_s/2\pi c I_c$ is the Josephson inductance [see Eq. (18.66)], the dimensionless potential $u(\Phi; \Phi_e)$ is given by

$$u(\Phi; \Phi_e) = (\Phi - \Phi_e)^2 - 2\beta_L \cos \Phi, \quad (18.86)$$

and the dimensionless parameter β_L is given by

$$\beta_L = \frac{2\pi A I_c}{\phi_s}. \quad (18.87)$$

The resulting Euler - Lagrange equation of motion (1.8) is given by

$$\frac{d}{dt} \left(\frac{\partial \mathcal{L}}{\partial \dot{\Phi}} \right) = \frac{\partial \mathcal{L}}{\partial \Phi}, \quad (18.88)$$

thus

$$\frac{A}{L_J \omega_p^2} \ddot{\Phi} + \Phi - \Phi_e + \beta_L \sin \Phi = 0. \quad (18.89)$$

With the help of Eqs. (18.72), (18.75) and (18.77) the equation of motion can be rewritten as

$$I_s = I_c \sin \Theta + C_J \dot{V}. \quad (18.90)$$

The above equation states that the circulating current I_s equals the sum of the current $I_c \sin \Theta$ through the Josephson junction and the current $C_J \dot{V}$ through the capacitor.

18.3.2 Readout with LC Resonator

Magnetic field sensing using an RF SQUID can be performed by inductively coupling the superconducting loop to an LC resonator (see Fig. 18.2), which is made of an inductor and a capacitor in parallel having inductance L and capacitance C respectively. The mutual inductance between the RF SQUID and the resonator is denoted by M . Detection is performed by injecting a monochromatic input current I_{in} into the LC resonator at a frequency close to the resonance frequency and measuring the output voltage V_{out} (see Fig. 18.2).

The total magnetic flux ϕ threading the SQUID loop for the current case is given by [compare with Eq. (18.75)]

$$\phi = \phi_e + \phi_i, \quad (18.91)$$

where the term ϕ_i represents the flux generated by both, the circulating current in the RF SQUID I_s and by the current in the inductor of the LC resonator I_L

$$\phi_i = A I_s + M I_L, \quad (18.92)$$

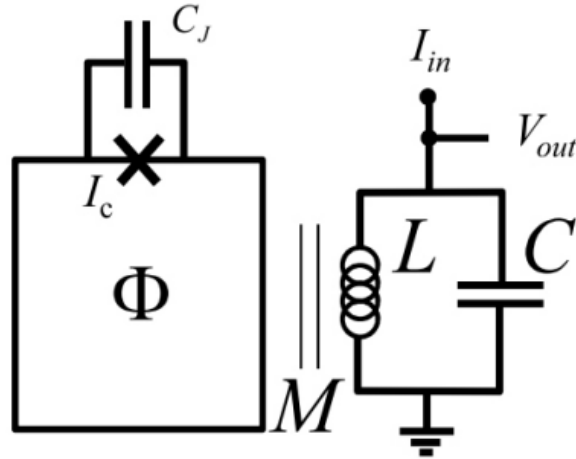

Fig. 18.2. The LC resonator that is coupled to the RF SQUID allows readout.

where Λ is the self inductance of the loop. Similarly, the magnetic flux φ in the inductor of the LC resonator is given by

$$\varphi = LI_L + MI_s . \quad (18.93)$$

In a matrix form Eqs. (18.92) and (18.93) can be rewritten as

$$\begin{pmatrix} \phi_i \\ \varphi \end{pmatrix} = \begin{pmatrix} \Lambda & M \\ M & L \end{pmatrix} \begin{pmatrix} I_s \\ I_L \end{pmatrix} . \quad (18.94)$$

Inverting the above relation allows expressing the currents I_s and I_L in terms of $\phi_i = \phi - \phi_e$ and φ

$$I_s = \frac{\phi_i}{\Lambda(1-K^2)} - \frac{M\varphi}{\Lambda L(1-K^2)} , \quad (18.95)$$

$$I_L = \frac{\varphi}{L(1-K^2)} - \frac{M\phi_i}{\Lambda L(1-K^2)} , \quad (18.96)$$

where the dimensionless constant K is given by

$$K = \frac{M}{\sqrt{\Lambda L}} . \quad (18.97)$$

Exercise 18.3.1. Show that the equations of motion governing the dynamics of the system are given by

$$\frac{\Lambda}{L_J} \frac{\ddot{\Phi}}{\omega_p^2} = - \frac{\Phi - \Phi_e - \frac{2\pi M \varphi}{\phi_s L}}{1 - K^2} - \beta_L \sin \Phi , \quad (18.98)$$

and

$$\frac{C\ddot{\varphi}}{c} = -\frac{\varphi - \frac{\phi_s M}{2\pi\Lambda}(\Phi - \Phi_e)}{L(1 - K^2)} + I_{\text{in}}. \quad (18.99)$$

Solution 18.3.1. The Lagrangian of the system $\mathcal{L} = T - U$ [see Eq. (1.16)] is expressed below as a function of the coordinates $\Phi = 2\pi\phi/\phi_s$ and φ and their time derivatives $\dot{\Phi}$ and $\dot{\varphi}$. The contributions to the total kinetic energy T are the capacitance energy of the Josephson junction that is given by Eq. (18.78) and the capacitance energy of the capacitor in the LC resonator, thus T is given by

$$T = \frac{C_J\phi_s^2\dot{\Phi}^2}{8\pi^2c^2} + \frac{C\dot{\varphi}^2}{2c^2}. \quad (18.100)$$

The inductive energy U_I stored in the RF SQUID loop and the lumped inductor L is calculated using Eqs. (18.95) and (18.96)

$$\begin{aligned} U_I &= \frac{1}{2c} (I_s \ I_L) \begin{pmatrix} \Lambda & M \\ M & L \end{pmatrix} \begin{pmatrix} I_s \\ I_L \end{pmatrix} \\ &= \frac{1}{2c(1 - K^2)} (\phi_i \ \varphi) \begin{pmatrix} \frac{1}{\Lambda} & -\frac{M}{\Lambda L} \\ -\frac{M}{\Lambda L} & \frac{1}{L} \end{pmatrix} \begin{pmatrix} \phi_i \\ \varphi \end{pmatrix} \\ &= \frac{\phi_i^2 - \frac{2\phi_i\varphi M}{\Lambda L} + \frac{\varphi^2}{L}}{2c(1 - K^2)} \\ &= \frac{\varphi^2}{2cL} + \frac{\left(\phi_i - \frac{M\varphi}{L}\right)^2}{2c\Lambda(1 - K^2)} \\ &= \frac{C\omega_e^2\varphi^2}{2c^2} + \frac{\phi_s^2\left(\Phi - \Phi_e - \frac{2\pi M\varphi}{\phi_s L}\right)^2}{8\pi^2c\Lambda(1 - K^2)}, \end{aligned} \quad (18.101)$$

where

$$\omega_e = \sqrt{\frac{c}{LC}} \quad (18.102)$$

is the LC angular resonance frequency. The total potential energy U is given by

$$U = U_I - \frac{I_{\text{in}}\varphi}{c} - \frac{\phi_s I_c}{2\pi c} \cos \Phi, \quad (18.103)$$

where the term $-I_{\text{in}}\varphi/c$ is the potential energy of the current source and $-(\phi_s I_c/2\pi c) \cos \Phi$ is the Josephson energy [see Eq. (18.81)]. With the help of the above relations one finds that the Lagrangian of the system $\mathcal{L} = T - U$ can be expressed as

$$\mathcal{L} = \mathcal{L}_0 + \mathcal{L}_1, \quad (18.104)$$

where \mathcal{L}_0 , which is given by

$$\mathcal{L}_0 = \frac{C\dot{\varphi}^2}{2c^2} - \frac{C\omega_e^2\varphi^2}{2c^2} + \frac{I_{\text{in}}\varphi}{c}, \quad (18.105)$$

is the Lagrangian of the driven LC resonator. The Lagrangian of the superconducting loop \mathcal{L}_1 is given by [see Eqs. (18.84), (18.85) and (18.87)]

$$\begin{aligned} \mathcal{L}_1 &= \frac{C_J\phi_s^2\dot{\Phi}^2}{8\pi^2c^2} - \frac{\phi_s^2\left(\Phi - \Phi_e - \frac{2\pi M\varphi}{\phi_s L}\right)^2}{8\pi^2c\Lambda(1-K^2)} + \frac{\phi_s I_c}{2\pi c} \cos \Phi \\ &= E_0 \left(\frac{\Lambda}{L_J} \frac{\dot{\Phi}^2}{\omega_p^2} - u_K(\Phi; \Phi_{e,\text{eff}}) \right), \end{aligned} \quad (18.106)$$

where the dimensionless potential $u_K(\Phi; \Phi_{e,\text{eff}})$ is given by [compare with Eq. (18.86)]

$$u_K(\Phi; \Phi_{e,\text{eff}}) = \frac{(\Phi - \Phi_{e,\text{eff}})^2}{1 - K^2} - 2\beta_L \cos \Phi, \quad (18.107)$$

and where the effective external flux $\Phi_{e,\text{eff}}$ is given by

$$\Phi_{e,\text{eff}} = \Phi_e + \frac{2\pi M\varphi}{\phi_s L}. \quad (18.108)$$

Note that \mathcal{L}_1 depends on the effective external flux $\Phi_{e,\text{eff}}$, which, in turn, depends on the coordinate φ of the LC resonator [see Eq. (18.108)]. This dependence gives rise to the coupling between the LC resonator and the RF SQUID. The Euler - Lagrange equations (1.8), which are given by

$$\frac{d}{dt} \left(\frac{\partial \mathcal{L}}{\partial \dot{\Phi}} \right) = \frac{\partial \mathcal{L}}{\partial \Phi}, \quad (18.109)$$

$$\frac{d}{dt} \left(\frac{\partial \mathcal{L}}{\partial \dot{\varphi}} \right) = \frac{\partial \mathcal{L}}{\partial \varphi}, \quad (18.110)$$

leads to Eqs. (18.98) and (18.99).

With the help of Eqs. (18.95) and (18.96) one finds that the equations of motion (18.98) and (18.99) can be rewritten as

$$I_s = I_c \sin \Theta - \frac{C_J \ddot{\Phi}}{c}, \quad (18.111)$$

and

$$I_{\text{in}} = \frac{C \ddot{\varphi}}{c} + I_L. \quad (18.112)$$

While Eq. (18.111) expresses the law of current conservation in the SQUID loop, Eq. (18.112) expresses the same law in the LC resonator.

For a given value of the coordinate φ , local minima points of the potential $u_K(\Phi; \Phi_{e,\text{eff}})$ are found by solving [see Eq. (18.107)]

$$0 = \frac{\Phi - \Phi_{e,\text{eff}}}{\beta_L (1 - K^2)} + \sin \Phi . \quad (18.113)$$

When $\beta_L (1 - K^2) < 1$ the above equation has a single solution, which to first order in $\beta_L (1 - K^2)$ is given by

$$\Phi = \Phi_{e,\text{eff}} - \beta_L (1 - K^2) \sin \Phi_{e,\text{eff}} . \quad (18.114)$$

As will be shown below, when the dynamics of the LC resonator can be considered as slow in comparison with the dynamics of the RF SQUID, i.e. when $\omega_e \ll \omega_p$, the effective resonance frequency of the LC resonator, which is denoted by $\omega_{e,\text{eff}}$, becomes periodically dependent on the magnetic flux Φ_e that is externally applied to the RF SQUID. This dependency can be utilized for magnetic fields sensing using the system under study.

Exercise 18.3.2. Consider the case where $\beta_L \ll 1$, $K^2 \ll 1$ and $\omega_e \ll \omega_p$. Show that for this case the effective value of the angular resonance frequency of the LC resonator is approximately given by

$$\omega_{e,\text{eff}} = \omega_e \left(1 + \frac{\beta_L K^2 \cos \Phi_e}{2} \right) . \quad (18.115)$$

Solution 18.3.2. In terms of the coordinates

$$\xi = \frac{\sqrt{C}}{c} \varphi , \quad (18.116)$$

$$\eta = \frac{\sqrt{C_J} \phi_s}{2\pi c} \Phi , \quad (18.117)$$

the Lagrangian (18.104) can be expressed as (the driving term proportional to I_{in} is disregarded)

$$\mathcal{L} = \frac{\dot{\xi}^2 + \dot{\eta}^2}{2} - U_g(\xi, \eta) , \quad (18.118)$$

where the potential $U_g(\xi, \eta)$ is given by [see Eqs. (18.87), (18.97) and (18.102)]

$$U_g = \frac{\omega_e^2 \xi^2}{2} + \frac{\omega_e^2}{\beta_p} \left(\frac{\left(\eta - \beta_p^{1/2} K \xi - \frac{\Phi_e}{\beta_s} \right)^2}{2(1 - K^2)} - \frac{\beta_L \cos(\beta_s \eta)}{\beta_s^2} \right) , \quad (18.119)$$

where

$$\beta_s = \frac{2\pi c}{\phi_s \sqrt{C_J}}, \quad (18.120)$$

$$\beta_p = \frac{AC_J}{LC}. \quad (18.121)$$

Let (ξ_0, η_0) be a local minima point of U_g , i.e. $\partial U_g / \partial \xi = \partial U_g / \partial \eta = 0$ at $(\xi, \eta) = (\xi_0, \eta_0)$. Near that point to second order in $\delta \xi = \xi - \xi_0$ and in $\delta \eta = \eta - \eta_0$ one has

$$U_g = U_g(\xi_0, \eta_0) + \frac{1}{2} (\delta \xi \ \delta \eta) M \begin{pmatrix} \delta \xi \\ \delta \eta \end{pmatrix}, \quad (18.122)$$

where the matrix M is given by

$$M = \begin{pmatrix} \frac{\partial^2 U_g}{\partial \xi^2} & \frac{\partial^2 U_g}{\partial \xi \partial \eta} \\ \frac{\partial^2 U_g}{\partial \xi \partial \eta} & \frac{\partial^2 U_g}{\partial \eta^2} \end{pmatrix}, \quad (18.123)$$

and where

$$\frac{\partial^2 U_g}{\partial \xi^2} = \frac{\omega_e^2}{1 - K^2}, \quad (18.124)$$

$$\frac{\partial^2 U_g}{\partial \xi \partial \eta} = -\frac{K \omega_e^2}{\beta_p^{1/2} (1 - K^2)}, \quad (18.125)$$

$$\frac{\partial^2 U_g}{\partial \eta^2} = \frac{\omega_e^2}{\beta_p} \frac{1 + (1 - K^2) \beta_L \cos(\beta_s \eta)}{1 - K^2}. \quad (18.126)$$

Let ω_1^2 and ω_2^2 be eigenvalues of M , where ω_1 is assumed to be the effective value of the angular resonance frequency of the LC resonator, i.e. $\omega_1 = \omega_{e,\text{eff}}$. The following holds

$$\det M = \omega_1^2 \omega_2^2, \quad (18.127)$$

$$\text{Tr } M = \omega_1^2 + \omega_2^2. \quad (18.128)$$

In the current case it is expected that $\omega_1 \ll \omega_2$, since $\omega_e \ll \omega_p$. For this case the angular frequency ω_1 can be evaluated using the approximation

$$\left(\frac{\det M}{\text{Tr } M} \right)^{1/2} \simeq \omega_1. \quad (18.129)$$

To lowest nonvanishing order in K , β_L and β_p one finds that

$$\omega_{e,\text{eff}} = \omega_e \left(1 + \frac{\beta_L K^2 \cos(\beta_s \eta)}{2} \right), \quad (18.130)$$

in agreement with Eq. (18.115) (recall that $\beta_s \eta = \Phi$ and $\Phi \simeq \Phi_e$ when $\beta_L \ll 1$).

18.3.3 Hamiltonian

The variables canonically conjugate to Φ and φ are given by [see Eqs. (1.20) and (18.104)]

$$Q = \frac{\partial \mathcal{L}}{\partial \dot{\Phi}} = \frac{2E_0 A \dot{\Phi}}{L_J \omega_p^2}, \quad (18.131)$$

$$q = \frac{\partial \mathcal{L}}{\partial \dot{\varphi}} = \frac{C \dot{\varphi}}{c^2}. \quad (18.132)$$

The Hamiltonian is given by [see Eq. (1.22)]

$$\mathcal{H} = Q \dot{\Phi} + q \dot{\varphi} - \mathcal{L} = \mathcal{H}_0 + \mathcal{H}_1, \quad (18.133)$$

where

$$\mathcal{H}_0 = \frac{c^2 q^2}{2C} + \frac{C \omega_e^2 \varphi^2}{2c^2} - \frac{I_{\text{in}} \varphi}{c}, \quad (18.134)$$

and where

$$\mathcal{H}_1 = \frac{L_J \omega_p^2 Q^2}{4E_0 A} + E_0 u_K(\Phi; \Phi_{e,\text{eff}}). \quad (18.135)$$

Quantization is achieved by regarding the variables $\{\Phi, Q, \varphi, q\}$ as Hermitian operators satisfying the following commutation relations [see Eqs. (3.6), (3.7) and (3.8)]

$$[\Phi, Q] = [\varphi, q] = i\hbar, \quad (18.136)$$

and

$$[\varphi, \Phi] = [\varphi, Q] = [q, \Phi] = [q, Q] = 0. \quad (18.137)$$

In terms of the annihilation operator A , which is given by [see Eq. (5.9)]

$$A = \frac{1}{\sqrt{2\hbar}} \left(\sqrt{\frac{C\omega_e}{c^2}} \varphi + \frac{i}{\sqrt{\frac{C\omega_e}{c^2}}} q \right), \quad (18.138)$$

and the corresponding number operator N , which is given by [see Eq. (5.14)]

$$N = A^\dagger A = \frac{1}{\hbar\omega_e} \left(\frac{c^2 q^2}{2C} + \frac{C\omega_e^2 \varphi^2}{2c^2} \right) - \frac{1}{2}, \quad (18.139)$$

the Hamiltonian \mathcal{H}_0 becomes

$$\mathcal{H}_0 = \hbar\omega_e \left(N + \frac{1}{2} \right) - I_{\text{in}} \sqrt{\frac{\hbar}{2C\omega_e}} (A + A^\dagger), \quad (18.140)$$

and the term $\Phi_{e,\text{eff}}$ becomes [see Eq. (18.108)]

$$\Phi_{e,\text{eff}} = \Phi_e + \frac{K}{2} \sqrt{\frac{\hbar\omega_e}{E_0}} (A + A^\dagger). \quad (18.141)$$

Exercise 18.3.3. Show that

$$-c \frac{\partial \mathcal{H}}{\partial \phi_e} = I_s, \quad (18.142)$$

where I_s is the circulating current in the RF SQUID.

Solution 18.3.3. With the help of Eqs. (18.91), (18.107) and (18.135) one finds that

$$\begin{aligned} -c \frac{\partial \mathcal{H}}{\partial \phi_e} &= c \frac{2E_0}{1-K^2} \left(\frac{2\pi}{\phi_s} \right)^2 \left(\phi - \phi_e - \frac{M\varphi}{L} \right) \\ &= \frac{\phi_i - \frac{M\varphi}{L}}{\Lambda(1-K^2)}, \end{aligned} \quad (18.143)$$

in agreement with Eq. (18.142) [see Eq. (18.95)].

18.3.4 Flux Quantum Bit

Consider the case where the externally applied magnetic flux ϕ_e is chosen to be close to a half integer value in units of the superconducting flux quantum ϕ_s . The potential u_K (18.107) can be expressed as

$$u_K = \frac{(\Phi_r - \Phi_{e,\text{eff},r})^2}{1-K^2} + 2\beta_L \cos \Phi_r, \quad (18.144)$$

where $\Phi_{e,\text{eff},r}$ and Φ_r are defined by [see Eq. (18.108)]

$$\Phi_{e,\text{eff}} = \Phi_e + \frac{2\pi M\varphi}{\phi_s L} = \pi + \Phi_{e,\text{eff},r}, \quad (18.145)$$

$$\Phi = \pi + \Phi_r. \quad (18.146)$$

Consider the case where $\Phi_{e,\text{eff},r} = 0$ (i.e. $\Phi_{e,\text{eff}} = \pi$). For this case to second order in Φ_r the potential u_K is given by

$$u_K = 2\beta_L + \frac{1 - \beta_L(1-K^2)}{1-K^2} \Phi_r^2 + O(\Phi_r^4). \quad (18.147)$$

Thus if $\beta_L(1-K^2) > 1$ the point $\Phi_r = 0$ becomes a local maxima point of u . The corresponding potential barrier centered at $\Phi_r = 0$ (i.e. at $\Phi = \pi$) separates two symmetric potential wells on the right and on the left (see Fig. 18.3). At sufficiently low temperatures only the two lowest energy levels are expected to be occupied. In this limit the Hamiltonian of the system can be expressed in the basis of the states $|\leftarrow\rangle$ and $|\rightarrow\rangle$, that represent localized states in the left and right well, respectively, having opposite circulating currents. In this range the device can be used as an artificial two-level system (TLS), i.e. as a quantum bit (qubit in short).

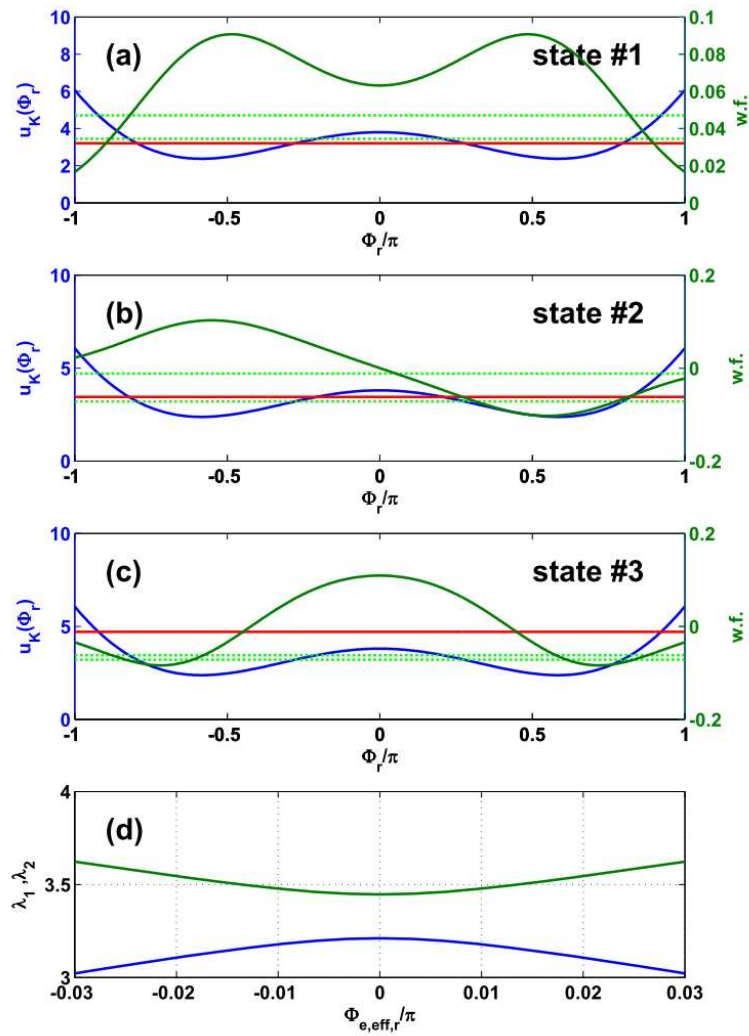

Fig. 18.3. Eigenstates of \mathcal{H}_1 . (a)-(c) The first 3 lowest energy states for the case $\Phi_{e,eff,r} = 0$. (d) The energy of the two lowest states vs. $\Phi_{e,eff,r}$.

18.3.5 Superconducting Cavity Quantum Electrodynamics

Cavity quantum electrodynamics (CQED) is the study of the interaction between photons confined in a cavity and atoms (natural or artificial). In the current device under study the RF SQUID plays the role of an artificial atom and the LC resonator plays the role of a cavity. In terms of the states $|\nearrow\rangle$ and $|\searrow\rangle$ the Hamiltonian \mathcal{H} (for the case $I_{\text{in}} = 0$) is taken to be given by [see Eq. (18.133)]

$$\begin{aligned} \hbar^{-1}\mathcal{H} &= \omega_e \left(A^\dagger A + \frac{1}{2} \right) \\ &+ \frac{\omega_f}{2} (|\nearrow\rangle \langle \searrow| - |\searrow\rangle \langle \nearrow|) \\ &+ \frac{\omega_\Delta}{2} (|\nearrow\rangle \langle \nearrow| + |\searrow\rangle \langle \searrow|) \\ &- g (A + A^\dagger) (|\nearrow\rangle \langle \searrow| - |\searrow\rangle \langle \nearrow|) . \end{aligned} \quad (18.148)$$

Exercise 18.3.4. Let I_{cc} ($-I_{\text{cc}}$) be the circulating current associated with the state $|\nearrow\rangle$ ($|\searrow\rangle$). Express the coefficient ω_f in terms of I_{cc} and the externally applied magnetic flux ϕ_e .

Solution 18.3.4. To ensure consistency with Eq. (18.142), i.e. to satisfy the requirement

$$I_{\text{cc}} = -c \langle \searrow| \frac{\partial \mathcal{H}}{\partial \phi_e} |\nearrow\rangle = c \langle \nearrow| \frac{\partial \mathcal{H}}{\partial \phi_e} |\searrow\rangle , \quad (18.149)$$

the coefficient ω_f is taken to be given by

$$\omega_f = \frac{2I_{\text{cc}}}{\hbar c} \left(\phi_e - \frac{\phi_s}{2} \right) = \frac{I_{\text{cc}}}{e} (\Phi_e - \pi) . \quad (18.150)$$

As will be shown below, the energy $\hbar\omega_\Delta$ is the smallest value of the qubit energy gap, which is obtained when $\omega_f = 0$ [see Eq. (18.155) below]. Note that it can be estimated using the WKB result (11.131) for the energy gap of a double well potential. The coefficient g , which is called the coupling constant, is given by [see Eq. (18.141)]

$$g = -\frac{I_{\text{cc}}K}{4e} \sqrt{\frac{\hbar\omega_e}{E_0}} . \quad (18.151)$$

Exercise 18.3.5. Consider the decoupled case, i.e. the case where $g = 0$. Find the eigenstates and eigenenergies of the qubit.

Solution 18.3.5. The energy eigenstates of the decoupled qubit $|\pm\rangle$ are given by [see Eqs. (6.301) and (6.302)]

$$\begin{pmatrix} |+\rangle \\ |-\rangle \end{pmatrix} = \begin{pmatrix} \cos \frac{\theta}{2} & \sin \frac{\theta}{2} \\ -\sin \frac{\theta}{2} & \cos \frac{\theta}{2} \end{pmatrix} \begin{pmatrix} |\curvearrowright\rangle \\ |\curvearrowleft\rangle \end{pmatrix}, \quad (18.152)$$

where

$$\tan \theta = \frac{\omega_{\Delta}}{\omega_{\text{f}}}, \quad (18.153)$$

and the corresponding eigenenergies are

$$\varepsilon_{\pm} = \mp \frac{\hbar \omega_{\text{a}}}{2}, \quad (18.154)$$

where

$$\omega_{\text{a}} = \sqrt{\omega_{\text{f}}^2 + \omega_{\Delta}^2}. \quad (18.155)$$

The following relations

$$|\curvearrowright\rangle \langle \curvearrowleft| - |\curvearrowleft\rangle \langle \curvearrowright| = \cos \theta \Sigma_z - \sin \theta (\Sigma_+ + \Sigma_-), \quad (18.156)$$

and

$$|\curvearrowright\rangle \langle \curvearrowright| + |\curvearrowleft\rangle \langle \curvearrowleft| = \sin \theta \Sigma_z + \cos \theta (\Sigma_+ + \Sigma_-), \quad (18.157)$$

hold, where

$$\Sigma_z = |+\rangle \langle +| - |-\rangle \langle -|, \quad (18.158)$$

$$\Sigma_+ = |+\rangle \langle -|, \quad (18.159)$$

$$\Sigma_- = |-\rangle \langle +|, \quad (18.160)$$

and thus the Hamiltonian \mathcal{H} can be expressed as

$$\begin{aligned} \hbar^{-1} \mathcal{H} &= \omega_{\text{e}} \left(A^{\dagger} A + \frac{1}{2} \right) - \frac{\omega_{\text{a}}}{2} \Sigma_z \\ &\quad - g (A + A^{\dagger}) [\cos \theta \Sigma_z - \sin \theta (\Sigma_+ + \Sigma_-)], \end{aligned} \quad (18.161)$$

or

$$\mathcal{H} = \mathcal{H}_{\text{JC}} + \mathcal{V}_{\text{BS}}, \quad (18.162)$$

where \mathcal{H}_{JC} , which is given by

$$\begin{aligned} \hbar^{-1} \mathcal{H}_{\text{JC}} &= \omega_{\text{e}} \left(A^{\dagger} A + \frac{1}{2} \right) - \frac{\omega_{\text{a}}}{2} \Sigma_z \\ &\quad + g_1 (A^{\dagger} \Sigma_- + A \Sigma_+), \end{aligned} \quad (18.163)$$

is the so-called Jaynes-Cummings Hamiltonian [compare with Eq. (9.79)], the term \mathcal{V}_{BS} is given by

$$\hbar^{-1}\mathcal{V}_{\text{BS}} = g_1 [A\Sigma_- + \Sigma_+A^\dagger - (A + A^\dagger)\Sigma_z \cot\theta] , \quad (18.164)$$

and g_1 is given by

$$g_1 = g \sin\theta . \quad (18.165)$$

Exercise 18.3.6. In the rotating wave approximation (RWA), in which rapidly oscillating terms are disregarded, the term \mathcal{V}_{BS} is ignored. Find the eigenstates and eigenenergies in this approximation.

Solution 18.3.6. Consider the pair of states $|n, +\rangle$ and $|n+1, -\rangle$. The following holds [see Eq. (18.163)]

$$\begin{aligned} \mathcal{H}_{\text{JC}} |n, +\rangle &= \hbar\omega_e (n+1) |n, +\rangle \\ &\quad - \frac{\hbar\Delta}{2} |n, +\rangle + \hbar g_1 \sqrt{n+1} |n+1, -\rangle , \end{aligned} \quad (18.166)$$

and

$$\begin{aligned} \mathcal{H}_{\text{JC}} |n+1, -\rangle &= \hbar\omega_e (n+1) |n+1, -\rangle \\ &\quad + \frac{\hbar\Delta}{2} |n+1, -\rangle + \hbar g_1 \sqrt{n+1} |n, +\rangle , \end{aligned} \quad (18.167)$$

where

$$\Delta = \omega_e - \omega_a , \quad (18.168)$$

or in a matrix form

$$\begin{aligned} &\mathcal{H}_{\text{JC}} \begin{pmatrix} |n, +\rangle \\ |n+1, -\rangle \end{pmatrix} \\ &= \hbar \left[\omega_e (n+1) \begin{pmatrix} 1 & 0 \\ 0 & 1 \end{pmatrix} + \frac{\omega_n}{2} \begin{pmatrix} \cos\theta_n & \sin\theta_n \\ \sin\theta_n & -\cos\theta_n \end{pmatrix} \right] \\ &\quad \times \begin{pmatrix} |n, +\rangle \\ |n+1, -\rangle \end{pmatrix} , \end{aligned} \quad (18.169)$$

where

$$\omega_n = \sqrt{\Delta^2 + 4g_1^2 (n+1)} , \quad (18.170)$$

$$\tan\theta_n = -\frac{2g_1\sqrt{n+1}}{\Delta} . \quad (18.171)$$

Thus, the states $|n_+\rangle$ and $|n_-\rangle$, which are given by [see Eqs. (6.301) and (6.302)]

$$|n_+\rangle = \cos \frac{\theta_n}{2} |n, +\rangle + \sin \frac{\theta_n}{2} |n+1, -\rangle, \quad (18.172)$$

$$|n_-\rangle = -\sin \frac{\theta_n}{2} |n, +\rangle + \cos \frac{\theta_n}{2} |n+1, -\rangle, \quad (18.173)$$

are eigenstates of \mathcal{H}_{JC} and the following holds

$$\mathcal{H}_{\text{JC}} |n_\pm\rangle = E_{n_\pm} |n_\pm\rangle, \quad (18.174)$$

where

$$\begin{aligned} E_{n_\pm} &= \hbar \left[\omega_e (n+1) \pm \frac{\omega_n}{2} \right] \\ &= \hbar \left[\omega_e (n+1) \pm \sqrt{\frac{\Delta^2}{4} + (n+1)g_1^2} \right]. \end{aligned} \quad (18.175)$$

The ground state $|0, -\rangle$ satisfies the relation

$$\mathcal{H}_{\text{JC}} |0, -\rangle = E_g |0, -\rangle, \quad (18.176)$$

where

$$E_g = \frac{\hbar\Delta}{2} \quad (18.177)$$

is the ground state energy.

While in the RWA the term \mathcal{V}_{BS} is disregarded, its effect, gives rise to the so-called Bloch-Siegert shift.

Exercise 18.3.7. Calculate the eigenenergies of \mathcal{H} to lowest nonvanishing order in perturbation theory.

Solution 18.3.7. As can be seen from Eq. (18.164), the perturbation \mathcal{V}_{BS} is proportional to g_1 . The exact eigenstates of \mathcal{H}_{JC} are given by Eqs. (18.172), (18.173) and (18.176). All diagonal matrix elements of \mathcal{V}_{BS} vanish, and consequently the lowest nonvanishing order of the perturbation expansion is the second one [see Eq. (9.32)]. The nonvanishing matrix elements of \mathcal{V}_{BS} are evaluated below to first order in g_1

$$\langle n'_+ | \hbar^{-1} \mathcal{V}_{\text{BS}} |0, -\rangle = g_1 \delta_{n',1}, \quad (18.178)$$

$$\langle n'_- | \hbar^{-1} \mathcal{V}_{\text{BS}} |0, -\rangle = g_1 \cot \theta \delta_{n',0}, \quad (18.179)$$

$$\langle n'_- | \hbar^{-1} \mathcal{V}_{\text{BS}} |n_+\rangle = g_1 \sqrt{n} \delta_{n',n-2}, \quad (18.180)$$

$$\langle n'_+ | \hbar^{-1} \mathcal{V}_{\text{BS}} | n_- \rangle = g_1 \sqrt{n+2} \delta_{n',n+2} , \quad (18.181)$$

$$\begin{aligned} & \langle n'_+ | \hbar^{-1} \mathcal{V}_{\text{BS}} | n_+ \rangle \\ & = -g_1 \cot \theta \left(\sqrt{n} \delta_{n',n-1} + \sqrt{n+1} \delta_{n',n+1} \right) , \end{aligned} \quad (18.182)$$

and

$$\begin{aligned} & \langle n'_- | \hbar^{-1} \mathcal{V}_{\text{BS}} | n_- \rangle \\ & = g_1 \cot \theta \left(\sqrt{n+1} \delta_{n',n-1} + \sqrt{n+2} \delta_{n',n+1} \right) . \end{aligned} \quad (18.183)$$

To second order in g_1 the energy of the ground state is found to be given by [see Eqs. (18.168), (18.170) and (18.177)]

$$\hbar^{-1} E_{\text{g}} = \frac{\Delta}{2} + \omega_{\text{BS},0} , \quad (18.184)$$

and the energies of the excited states by

$$\begin{aligned} \hbar^{-1} E_{n_{\pm}} & = (n+1) (\omega_e \pm \omega_{\text{BS}}) \\ & \pm \sqrt{\frac{\Delta^2}{4} + (n+1) g_1^2} + \omega_{\text{BS},0} , \end{aligned} \quad (18.185)$$

where [compare with Eq. (6.411)]

$$\omega_{\text{BS}} = \frac{g_1^2}{\omega_e + \omega_a} , \quad (18.186)$$

and where

$$\omega_{\text{BS},0} = -g_1^2 \left(\frac{1}{\omega_e + \omega_a} + \frac{\cot^2 \theta}{\omega_e} \right) . \quad (18.187)$$

The following holds

$$\hbar^{-1} (E_{n_-} - E_{\text{g}}) = (n+1) \left(\omega_e - \omega_{\text{BS}} + \frac{g_1^2}{\Delta} \right) + O(g_1^4) , \quad (18.188)$$

and

$$\hbar^{-1} (E_{n_+} - E_{0+}) = n \left(\omega_e + \omega_{\text{BS}} - \frac{g_1^2}{\Delta} \right) + O(g_1^4) , \quad (18.189)$$

thus in the linear regime and when $g_1^2/|\Delta| \ll \omega_e$ the system has two resonance frequencies given by $\omega_e \pm \omega_{\text{BS}} \mp g_1^2/\Delta$.

18.3.6 Damping

The effect of damping on both a resonator and on a TLS has been discussed in the previous chapter. In this section the effect of damping on the coupled resonator-qubit system is being studied.

Exercise 18.3.8. Employ the RWA to derive equations of motion for the operators A , Σ_z and Σ_- .

Solution 18.3.8. With the help of Eqs. (4.37) and (18.163) together with the commutation relations

$$[A, A^\dagger] = 1, \quad (18.190)$$

$$[\Sigma_z, \Sigma_+] = 2\Sigma_+, \quad (18.191)$$

$$[\Sigma_z, \Sigma_-] = -2\Sigma_-, \quad (18.192)$$

$$[\Sigma_+, \Sigma_-] = \Sigma_z, \quad (18.193)$$

one obtains (recall that in the RWA the term \mathcal{V}_{BS} is disregarded)

$$\frac{dA}{dt} = -i\omega_e A - ig_1 \Sigma_-, \quad (18.194)$$

$$\frac{d\Sigma_z}{dt} = 2ig_1 (\Sigma_- A^\dagger - A \Sigma_+), \quad (18.195)$$

$$\frac{d\Sigma_-}{dt} = -i\omega_a \Sigma_- + ig_1 A \Sigma_z, \quad (18.196)$$

where $g_1 = g \sin \theta$ [see Eq. (18.165)].

Damping can be taken into account by introducing the cavity decay rate γ_e [see Eq. (17.33)] and the qubit decay times T_1 and T_2 [see Eqs. (17.126) and (17.127)]. The equation of motion for the cavity operator A (18.194) leads to an equation of motion for the expectation value $\mathcal{A} = \langle A \rangle$ [see Eq. (17.34)], and the qubit equations of motion (18.195) and (18.196) lead to equations of motion for the expectation values $P_z = \langle \Sigma_z \rangle$ and $P_- = \langle \Sigma_- \rangle$ [see Eqs. (17.119) and (17.120)]

$$\frac{d\mathcal{A}}{dt} + (i\omega_e + \gamma_e) \mathcal{A} + ig_1 P_- = 0, \quad (18.197)$$

$$\frac{dP_z}{dt} + 2ig_1 (\mathcal{A}P_+ - P_- \mathcal{A}^*) = -\frac{P_z - P_{z0}}{T_1}, \quad (18.198)$$

$$\frac{dP_-}{dt} + i\omega_a P_- - ig_1 \mathcal{A}P_z = -\frac{P_-}{T_2}, \quad (18.199)$$

where P_{z0} is the value of P_z in thermal equilibrium [see Eq. (17.125)].

Consider the low temperature limit, for which $k_B T \ll \hbar\omega_a$ and consequently $P_{z0} \simeq -1$ [see Eq. (17.125)]. In this limit Eq. (18.199) can be simplified by employing the approximation $-ig_1 \mathcal{A}P_z \simeq ig_1 \mathcal{A}$, which allows expressing Eqs. (18.197) and (18.199) in a matrix form as

$$\frac{d}{dt} \begin{pmatrix} \mathcal{A} \\ P_- \end{pmatrix} + iM \begin{pmatrix} \mathcal{A} \\ P_- \end{pmatrix} = 0, \quad (18.200)$$

where

$$M = \begin{pmatrix} \omega_e - i\gamma_e & g_1 \\ g_1 & \omega_a - i\gamma_a \end{pmatrix}, \quad (18.201)$$

and where $\gamma_a = T_2^{-1}$. To lowest nonvanishing order in the coupling coefficient g_1 the eigenvalues of M , which are denoted by Ω_e and Ω_a , are found to be given by

$$\Omega_e = \omega_e - i\gamma_e + \frac{g_1^2}{\Delta - i(\gamma_e - \gamma_a)} + O(g_1^4), \quad (18.202)$$

and

$$\Omega_a = \omega_a - i\gamma_a - \frac{g_1^2}{\Delta - i(\gamma_e - \gamma_a)} + O(g_1^4), \quad (18.203)$$

where

$$\Delta = \omega_e - \omega_a. \quad (18.204)$$

In the limit $|(\gamma_e - \gamma_a)/\Delta| \ll 1$ Eqs. (18.202) and (18.203) become

$$\Omega_e = \omega_e + \frac{g_1^2}{\Delta} - i \left(\gamma_e + \frac{g_1^2(\gamma_a - \gamma_e)}{\Delta^2} \right) + O(g_1^4), \quad (18.205)$$

and

$$\Omega_a = \omega_a - \frac{g_1^2}{\Delta} - i \left(\gamma_a + \frac{g_1^2(\gamma_e - \gamma_a)}{\Delta^2} \right) + O(g_1^4). \quad (18.206)$$

Note that the above results (18.205) and (18.206) are valid only when $|g_1/\Delta| \ll 1$. The imaginary parts of Eqs. (18.205) and (18.206) represent the effective damping rates of the resonator and qubit, respectively. The coupling-induced (i.e. g_1 dependent) change in the damping rates is commonly referred to as the Purcell effect.

18.4 Circuit graph representation

Circuits made of two-terminal components (e.g. capacitors, inductors, Josephson junctions, and sources) can be analyzed using a graph representation. Let $\phi_b(t) = c \int^t dt' V_b(t')$ be the flux variable of a given two-terminal component, where $V_b(t')$ is the voltage across the component at time t' [compare

with Eq. (18.77)]. The energy U_b stored in the component is expressed as [compare with Eq. (18.60)]

$$U_b = \int^t dt' I_b(t') V_b(t') , \quad (18.207)$$

where $I_b(t')$ is the current through the component at time t' .

For the case of a linear inductor having inductance L , the relation $I_b = L^{-1}\phi_b$ yields $U_b = c^{-1}L^{-1} \int^t dt' \phi_b \dot{\phi}_b = c^{-1}L^{-1} \int^{\phi_b} d\phi'_b \phi'_b$, hence $U_b = \phi_b^2/(2cL)$ [compare with Eq. (18.79)]. For the case a linear capacitor having capacitance C the relation $C = q/V_b = cq/\dot{\phi}_b$ yields $I_b = \dot{q} = c^{-1}C\ddot{\phi}_b$, where q is the capacitor stored charge, hence $I_b V_b = c^{-2}C\ddot{\phi}_b \dot{\phi}_b = (C/(2c^2)) (d/dt) \dot{\phi}_b^2$, and thus $U_b = (C/(2c^2)) \dot{\phi}_b^2$ [compare with Eq. (18.78)]. For the case of a Josephson junction having critical current I_c the first Josephson relation, which can be expressed as $I_b = I_c \sin(2\pi\phi_b/\phi_s)$ [see Eqs. (18.56) and (18.58)], yields $U_b = -E_J \cos(2\pi\phi_b/\phi_s)$, where $E_J = \phi_s I_c / (2\pi c)$ [compare with Eq. (18.62) and see Eq. (18.63)]. An ideal source of current I_s can be represented by an inductor having infinite inductance, and thus its energy can be expressed as $U_b = c^{-1}I_s\phi_b$.

18.4.1 Lagrangian

Each two-terminal component in the circuit is represented by a graph branch connecting two graph nodes. The Lagrangian \mathcal{L} of the circuit can be derived by performing the following protocol:

1. Represent the circuit by a graph.
2. Label each branch with an arrow pointing from one end node to the other (chosen direction is arbitrary).
3. Select a ground node.
4. Select a spanning tree. This is done by removing some branches from the graph. The spanning tree has a unique path connecting any given node to the ground node, and it has no loops.
5. Label each node by a time varying flux variable $\phi(t)$, which is given by $\phi(t) = c \int^t dt' V(t')$, where $V(t')$ is the node voltage at time t' (with respect to the ground node).
6. For any branch belonging to the spanning tree, which is labelled by an arrow pointing from node n' to node n'' , the branch flux variable ϕ_b is given by $\phi_b = \phi_{n''} - \phi_{n'}$. A branch not belonging to the spanning tree is called a closure branch. The flux variable ϕ_b of a closure branch is given by $\phi_b = \phi_{n''} - \phi_{n'} + \phi_e$, where ϕ_e is the externally applied magnetic flux applied to the loop that is closed by the closure branch [compare with Eq. (18.75)].

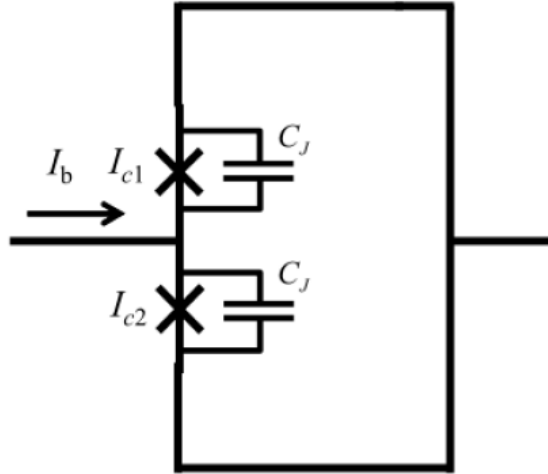

Fig. 18.4. The DC SQUID.

7. The contribution \mathcal{L}_b of a given branch having flux variable ϕ_b to the total Lagrangian \mathcal{L} is given by ($\mathcal{L}_b = U_b$ for a kinetic energy term, whereas $\mathcal{L}_b = -U_b$ for a potential energy term)

$$\mathcal{L}_b = \begin{cases} -\frac{\phi_b^2}{2c^2L} & \text{inductor} \\ \frac{C\phi_b^2}{2c^2} & \text{capacitor} \\ \frac{\phi_s I_c}{2\pi c} \cos \frac{2\pi\phi_b}{\phi_s} & \text{Josephson junction} \\ -c^{-1}I_s\phi_b & \text{current source} \end{cases} \quad (18.208)$$

The Lagrangian \mathcal{L} is the sum over all branch contributions \mathcal{L}_b .

18.4.2 DC SQUID

As an example, consider the so-called DC SQUID device seen in Fig. 18.4. The Josephson junctions on both arms of the DC SQUID have critical currents I_{c1} and I_{c2} respectively, and both have the same capacitance C_J . The self inductance of the loop is denoted as Λ . A bias current I_b is externally injected and a magnetic flux ϕ_e is externally applied to the loop.

The Lagrangian is derived using a graph representation of the circuit (see Fig. 18.5). The spanning tree is denoted by the lines colored by green. The total self inductance Λ of the loop (which is assumed to be equally divided between both arms of the DC SQUID) is taken into account by adding an inductor having inductance $\Lambda/2$ to each arm (see Fig 18.5).

The Lagrangian $\mathcal{L} = T - \tilde{U}$ is expressed as a function of the node flux variables ϕ_1 , ϕ_2 and ϕ_b , and their time derivatives $\dot{\phi}_1$, $\dot{\phi}_2$ and $\dot{\phi}_b$, where the

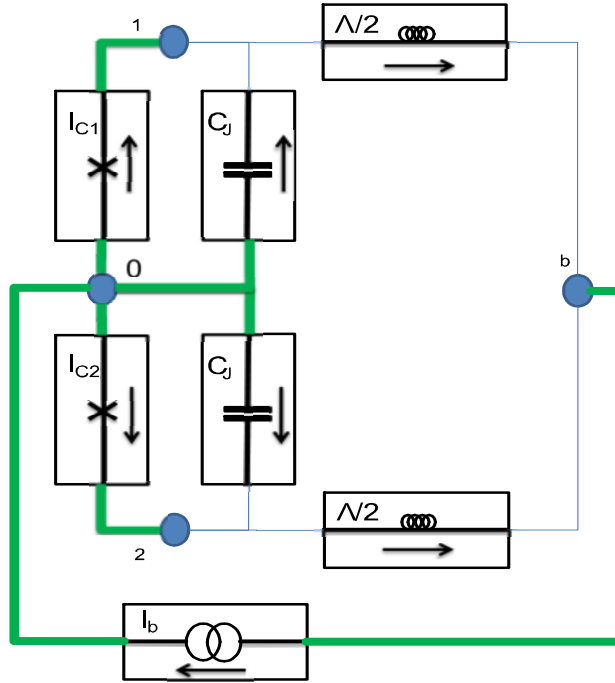

Fig. 18.5. Graph representation of a DC SQUID. The spanning tree is denoted by the lines colored by green.

kinetic energy T is given by

$$T = \frac{C_J \dot{\phi}_1^2}{2c^2} + \frac{C_J \dot{\phi}_2^2}{2c^2}, \quad (18.209)$$

and the potential energy \tilde{U} is given by

$$\begin{aligned} \tilde{U} = & -\frac{\phi_s I_{c1}}{2\pi c} \cos \frac{2\pi\phi_1}{\phi_s} - \frac{\phi_s I_{c2}}{2\pi c} \cos \frac{2\pi\phi_2}{\phi_s} - \frac{I_b \phi_b}{c} \\ & + \frac{(\phi_b - \phi_1 + \phi_e)^2}{c\Lambda} + \frac{(\phi_b - \phi_2)^2}{c\Lambda}. \end{aligned} \quad (18.210)$$

The Euler-Lagrange equation for the coordinate ϕ_b , which reads

$$\frac{\partial \mathcal{L}}{\partial \phi_b} = \frac{I_b}{c} - \frac{2(\phi_b - \phi_1 + \phi_e)}{c\Lambda} - \frac{2(\phi_b - \phi_2)}{c\Lambda} = 0, \quad (18.211)$$

yields

$$\phi_b = \frac{I_b \Lambda}{4} + \frac{\phi_1 + \phi_2 - \phi_e}{2}. \quad (18.212)$$

The above relation, which expresses the coordinate ϕ_b as a function of the coordinates ϕ_1 and ϕ_2 , allows replacing the potential energy \tilde{U} by a potential energy U , which is expressed as a function of ϕ_1 and ϕ_2 only [a constant term $-I_b^2\Lambda/(8c)$ is omitted from the expression for U]

$$U = -\frac{\phi_s I_{c1}}{2\pi c} \cos \frac{2\pi\phi_1}{\phi_s} - \frac{\phi_s I_{c2}}{2\pi c} \cos \frac{2\pi\phi_2}{\phi_s} - \frac{I_b(\phi_1 + \phi_2 - \phi_e)}{2c} + \frac{(\phi_2 - \phi_1 + \phi_e)^2}{2c\Lambda} . \quad (18.213)$$

The Euler-Lagrange equations for the coordinates ϕ_1 and ϕ_2 , which are given by

$$\frac{d}{dt} \left(\frac{\partial \mathcal{L}}{\partial \dot{\phi}_1} \right) = \frac{\partial \mathcal{L}}{\partial \phi_1} , \quad (18.214)$$

$$\frac{d}{dt} \left(\frac{\partial \mathcal{L}}{\partial \dot{\phi}_2} \right) = \frac{\partial \mathcal{L}}{\partial \phi_2} , \quad (18.215)$$

or

$$\frac{C_J \ddot{\phi}_1}{c} = -I_{c1} \sin \frac{2\pi\phi_1}{\phi_s} + \frac{I_b}{2} + \frac{\phi_2 - \phi_1 + \phi_e}{\Lambda} , \quad (18.216)$$

$$\frac{C_J \ddot{\phi}_2}{c} = -I_{c2} \sin \frac{2\pi\phi_2}{\phi_s} + \frac{I_b}{2} - \frac{\phi_2 - \phi_1 + \phi_e}{\Lambda} , \quad (18.217)$$

can be expressed as current conservation laws for the nodes 1 and 2 [note that $(I_1 - I_2)/2 = (\phi_2 - \phi_1 + \phi_e)/\Lambda$ and $I_b = I_1 + I_2$]

$$I_{c1} \sin \frac{2\pi\phi_1}{\phi_s} + \frac{C_J \ddot{\phi}_1}{c} = I_1 , \quad (18.218)$$

$$I_{c2} \sin \frac{2\pi\phi_2}{\phi_s} + \frac{C_J \ddot{\phi}_2}{c} = I_2 , \quad (18.219)$$

where the currents I_1 and I_2 , which are given by

$$I_1 = \frac{2(\phi_b - \phi_1 + \phi_e)}{\Lambda} , \quad (18.220)$$

$$I_2 = \frac{2(\phi_b - \phi_2)}{\Lambda} , \quad (18.221)$$

are the total currents flowing in the upper and lower arms respectively. The total voltage across the DC SQUID V_S is given by [see Eq. (18.212)]

$$V_S = \frac{\dot{\phi}_b}{c} = \frac{d}{dt} \frac{\frac{I_b \Lambda}{2} + \phi_1 + \phi_2 - \phi_e}{2c} . \quad (18.222)$$

18.5 Dielectric Response

In this section the dielectric function $\epsilon(\mathbf{q}, \omega)$ is defined, and then evaluated for some limiting cases. The results are employed for two applications. In the first one the effect of superconductivity on the dielectric response is estimated using the so-called two-fluid model. The second application deals with phonon-mediated electron-electron interaction. A simplified version of the mediated interaction will be employed in the following section for deriving the Hamiltonian of the BCS model of superconductivity.

18.5.1 Dielectric Function

The macroscopic Maxwell's equations (in Gaussian units) for the electric field \mathbf{E} , electric displacement \mathbf{D} , magnetic induction \mathbf{B} and magnetic field \mathbf{H} in the presence of external charge density ρ_{ext} and external current density \mathbf{J}_{ext} are given by

$$\nabla \times \mathbf{H} = \frac{4\pi}{c} \mathbf{J}_{\text{ext}} + \frac{1}{c} \frac{\partial \mathbf{D}}{\partial t}, \quad (18.223)$$

$$\nabla \times \mathbf{E} = -\frac{1}{c} \frac{\partial \mathbf{B}}{\partial t}, \quad (18.224)$$

$$\nabla \cdot \mathbf{D} = 4\pi \rho_{\text{ext}}, \quad (18.225)$$

$$\nabla \cdot \mathbf{B} = 0. \quad (18.226)$$

For an isotropic and linear medium the following relations hold

$$\mathbf{D} = \mathbf{E} + 4\pi \mathbf{P}, \quad (18.227)$$

$$\mathbf{D} = \epsilon \mathbf{E}, \quad (18.228)$$

$$\mathbf{P} = \chi_e \mathbf{E}, \quad (18.229)$$

$$\mathbf{B} = \mathbf{H} + 4\pi \mathbf{M}, \quad (18.230)$$

$$\mathbf{B} = \mu \mathbf{H}, \quad (18.231)$$

$$\mathbf{M} = \chi_m \mathbf{H}, \quad (18.232)$$

where \mathbf{P} is the electric polarization, $\epsilon = 1 + 4\pi\chi_e$ is the permittivity (dielectric constant of the medium), χ_e is the electric susceptibility, \mathbf{M} is the magnetization, $\mu = 1 + 4\pi\chi_m$ is the permeability and χ_m is the magnetic susceptibility.

In general, a scalar function $f(\mathbf{r}, t)$ can be Fourier expanded as

$$f(\mathbf{r}, t) = \int d\mathbf{q} \int d\omega e^{i(\mathbf{q}\cdot\mathbf{r} - \omega t)} f(\mathbf{q}, \omega), \quad (18.233)$$

and a vector function $\mathbf{F}(\mathbf{r}, t)$ can be Fourier expanded as

$$\mathbf{F}(\mathbf{r}, t) = \int d\mathbf{q} \int d\omega e^{i(\mathbf{q}\cdot\mathbf{r} - \omega t)} \mathbf{F}(\mathbf{q}, \omega). \quad (18.234)$$

A vector function $\mathbf{F}(\mathbf{r}, t)$ can be decomposed into longitudinal and transverse parts with respect to the wave vector \mathbf{q} according to

$$\mathbf{F} = \mathbf{F}_L + \mathbf{F}_T, \quad (18.235)$$

where the longitudinal part is given by $\mathbf{F}_L = (\hat{\mathbf{q}} \cdot \mathbf{F}) \hat{\mathbf{q}}$, the transverse one is given by $\mathbf{F}_T = (\hat{\mathbf{q}} \times \mathbf{F}) \times \hat{\mathbf{q}}$, and where $\hat{\mathbf{q}} = \mathbf{q}/|\mathbf{q}|$ is a unit vector in the direction of \mathbf{q} . The following holds $\nabla \cdot \mathbf{F} = \nabla \cdot \mathbf{F}_L$ and $\nabla \times \mathbf{F} = \nabla \times \mathbf{F}_T$. Recall that for a general scalar ϕ and a vector \mathbf{A} the following holds

$$\begin{aligned} \nabla \cdot (\phi \mathbf{A}) &= \phi \nabla \cdot \mathbf{A} + \mathbf{A} \cdot \nabla \phi, \\ \nabla \times (\phi \mathbf{A}) &= \phi \nabla \times \mathbf{A} - \mathbf{A} \times \nabla \phi, \end{aligned}$$

thus

$$\nabla \cdot \mathbf{F} = \int d\mathbf{q} \int d\omega e^{i(\mathbf{q} \cdot \mathbf{r} - \omega t)} i\mathbf{q} \cdot \mathbf{F}_L(\mathbf{q}, \omega), \quad (18.236)$$

and

$$\nabla \times \mathbf{F} = \int d\mathbf{q} \int d\omega e^{i(\mathbf{q} \cdot \mathbf{r} - \omega t)} i\mathbf{q} \times \mathbf{F}_T(\mathbf{q}, \omega). \quad (18.237)$$

With the help of the above relations the Maxwell's equations (18.223), (18.224), (18.225) and (18.226) can be Fourier transformed into

$$i\mathbf{q} \times \mathbf{H}_T(\mathbf{q}, \omega) = \frac{4\pi}{c} \mathbf{J}_{\text{ext}}(\mathbf{q}, \omega) - \frac{i\omega}{c} \mathbf{D}(\mathbf{q}, \omega), \quad (18.238)$$

$$\mathbf{q} \times \mathbf{E}_T(\mathbf{q}, \omega) = \frac{\omega}{c} \mathbf{B}(\mathbf{q}, \omega), \quad (18.239)$$

$$i\mathbf{q} \cdot \mathbf{D}_L(\mathbf{q}, \omega) = 4\pi \rho_{\text{ext}}(\mathbf{q}, \omega), \quad (18.240)$$

$$\mathbf{q} \cdot \mathbf{B}_L(\mathbf{q}, \omega) = 0. \quad (18.241)$$

While the external charge density ρ_{ext} is related to \mathbf{D} by the relation [see Eq. (18.225)]

$$\nabla \cdot \mathbf{D} = 4\pi \rho_{\text{ext}}, \quad (18.242)$$

the induced charge density ρ_{ind} , which is defined as the change in charge density with respect to the unperturbed case, is related to the electric polarization by the relation $\nabla \cdot \mathbf{P} = -\rho_{\text{ind}}$, and the total charge density $\rho_{\text{ind}} + \rho_{\text{ext}}$ is related to the electric field \mathbf{E} by the relation

$$\nabla \cdot \mathbf{E} = 4\pi (\rho_{\text{ind}} + \rho_{\text{ext}}). \quad (18.243)$$

Applying the Fourier transform to Eq. (18.243) yields

$$i\mathbf{q} \cdot \mathbf{E}_L(\mathbf{q}, \omega) = 4\pi (\rho_{\text{ind}}(\mathbf{q}, \omega) + \rho_{\text{ext}}(\mathbf{q}, \omega)). \quad (18.244)$$

The longitudinal dielectric function $\epsilon(\mathbf{q}, \omega)$, which is defined by [compare with Eq. (18.228)]

$$\epsilon(\mathbf{q}, \omega) \equiv \frac{|\mathbf{D}_L(\mathbf{q}, \omega)|}{|\mathbf{E}_L(\mathbf{q}, \omega)|}, \quad (18.245)$$

is thus given by [see Eqs. (18.240) and (18.244)]

$$\epsilon(\mathbf{q}, \omega) = \frac{\rho_{\text{ext}}(\mathbf{q}, \omega)}{\rho_{\text{ext}}(\mathbf{q}, \omega) + \rho_{\text{ind}}(\mathbf{q}, \omega)}. \quad (18.246)$$

For a general longitudinal field \mathbf{F}_L the following holds $\nabla \times \mathbf{F}_L = 0$, and thus both \mathbf{D}_L and \mathbf{E}_L can be expressed in terms of scalar potentials as

$$\mathbf{D}_L(\mathbf{r}, t) = -\nabla \varphi_{\text{ext}}(\mathbf{r}, t), \quad (18.247)$$

$$\mathbf{E}_L(\mathbf{r}, t) = -\nabla \varphi(\mathbf{r}, t), \quad (18.248)$$

and thus [see Eqs. (18.233) and (18.234)]

$$\mathbf{D}_L(\mathbf{q}, \omega) = -i\mathbf{q}\varphi_{\text{ext}}(\mathbf{q}, \omega), \quad (18.249)$$

$$\mathbf{E}_L(\mathbf{q}, \omega) = -i\mathbf{q}\varphi(\mathbf{q}, \omega). \quad (18.250)$$

Consequently, one finds that the longitudinal dielectric function $\epsilon(\mathbf{q}, \omega)$ can alternatively be expressed as [see Eq. (18.245)]

$$\epsilon(\mathbf{q}, \omega) = \frac{\varphi_{\text{ext}}(\mathbf{q}, \omega)}{\varphi(\mathbf{q}, \omega)}, \quad (18.251)$$

or

$$\epsilon(\mathbf{q}, \omega) = 1 - \frac{4\pi}{|\mathbf{q}|^2} \frac{\rho_{\text{ind}}(\mathbf{q}, \omega)}{\varphi(\mathbf{q}, \omega)}. \quad (18.252)$$

Long Wavelength Limit. The dielectric function $\epsilon(\mathbf{q}, \omega)$ of a conductor in the limit $|\mathbf{q}| \rightarrow 0$, i.e. in the homogeneous case, can be evaluated using the so-called Drude model. Consider a conductor containing charge carriers having charge q and mass m in an electromagnetic field. The density of charge carriers (i.e. number per unit volume) is n . Scattering is taken into account in the Drude model by adding a damping term to the classical equation of motion (18.4)

$$m \left(\ddot{\mathbf{r}} + \frac{1}{\tau_{\text{tr}}} \dot{\mathbf{r}} \right) = q \left(\mathbf{E} + \frac{1}{c} \dot{\mathbf{r}} \times \mathbf{B} \right), \quad (18.253)$$

where τ_{tr} is the so-called scattering time. For simplicity the applied magnetic field is assumed to vanish, i.e. $\mathbf{B} = 0$. In terms of the current density vector \mathbf{J} , which is related to the velocity vector $\mathbf{v} = \dot{\mathbf{r}}$ by the relation

$$\mathbf{v} = \frac{\mathbf{J}}{qn}, \quad (18.254)$$

Eq. (18.253) yields

$$\frac{m}{q^2 n} \left(\frac{\partial \mathbf{J}}{\partial t} + \frac{1}{\tau_{\text{tr}}} \mathbf{J} \right) = \mathbf{E} . \quad (18.255)$$

The current density \mathbf{J} is related to the induced charge density ρ_{ind} by the continuity equation (18.7)

$$\frac{d\rho_{\text{ind}}}{dt} + \nabla \cdot \mathbf{J} = 0 . \quad (18.256)$$

Applying $\nabla \cdot$ to Eq. (18.255) and using Eqs. (18.243) and (18.256) lead to

$$\frac{d^2 \rho_{\text{ind}}}{dt^2} + \frac{1}{\tau_{\text{tr}}} \frac{d\rho_{\text{ind}}}{dt} = -\omega_{\text{p}}^2 (\rho_{\text{ind}} + \rho_{\text{ext}}) , \quad (18.257)$$

where ω_{p} , which is given by

$$\omega_{\text{p}}^2 = \frac{4\pi q^2 n}{m} , \quad (18.258)$$

is the so-called plasma frequency.

By employing Fourier expansion

$$\mathbf{J}(t) = \int d\omega e^{-i\omega t} \mathbf{J}(\omega) , \quad (18.259)$$

$$\mathbf{E}(t) = \int d\omega e^{-i\omega t} \mathbf{E}(\omega) , \quad (18.260)$$

$$\rho_{\text{ind}}(t) = \int d\omega e^{-i\omega t} \rho_{\text{ind}}(\omega) , \quad (18.261)$$

$$\rho_{\text{ext}}(t) = \int d\omega e^{-i\omega t} \rho_{\text{ext}}(\omega) , \quad (18.262)$$

Eq. (18.255) becomes

$$\mathbf{J}(\omega) = \sigma(\omega) \mathbf{E}(\omega) , \quad (18.263)$$

where $\sigma(\omega)$, which is given by

$$\sigma(\omega) = \frac{\sigma_0}{1 - i\omega\tau_{\text{tr}}} , \quad (18.264)$$

is the so-called complex conductivity, and where

$$\sigma_0 = \frac{q^2 n \tau_{\text{tr}}}{m} , \quad (18.265)$$

and Eq. (18.257) becomes

$$\rho_{\text{ind}}(\omega) = \frac{\omega_{\text{p}}^2}{\omega^2 - \omega_{\text{p}}^2 + \frac{i\omega}{\tau_{\text{tr}}}} \rho_{\text{ext}}(\omega) . \quad (18.266)$$

Thus the dielectric function in the long wavelength limit $\epsilon(0, \omega)$ is given by [see Eq. (18.246)]

$$\epsilon(0, \omega) = \frac{\rho_{\text{ext}}(\omega)}{\rho_{\text{ext}}(\omega) + \rho_{\text{ind}}(\omega)} = 1 - \frac{\omega_{\text{p}}^2}{\omega^2} \frac{i\omega\tau_{\text{tr}}}{i\omega\tau_{\text{tr}} - 1}, \quad (18.267)$$

and the following holds [see Eq. (18.264)]

$$\epsilon(0, \omega) = 1 + \frac{4\pi i\sigma(\omega)}{\omega}. \quad (18.268)$$

Alternatively, in terms of the so-called skin depth δ_{sd} , which is given by

$$\delta_{\text{sd}} = \frac{c}{\omega_{\text{p}}} \sqrt{\frac{2}{\omega\tau_{\text{tr}}}}, \quad (18.269)$$

the dielectric function $\epsilon(0, \omega)$ (18.267) can be expressed as

$$\epsilon(0, \omega) = 1 + \frac{2ic^2}{\delta_{\text{sd}}^2 \omega^2} \frac{1}{1 - i\omega\tau_{\text{tr}}}. \quad (18.270)$$

Zero Frequency Limit. The dielectric function $\epsilon(\mathbf{q}, \omega)$ of a conductor in the limit $\omega \rightarrow 0$, i.e. in the static case, can be evaluated using the so-called Thomas-Fermi approximation. In terms of the induced charge density ρ_{ind} and the scalar potential φ the dielectric function $\epsilon(\mathbf{q}, 0)$ is given by [see Eq. (18.252)]

$$\epsilon(\mathbf{q}, 0) = 1 - \frac{4\pi}{|\mathbf{q}|^2} \frac{\rho_{\text{ind}}(\mathbf{q}, 0)}{\varphi(\mathbf{q}, 0)}. \quad (18.271)$$

The density of charge carriers n (charge carriers are assumed to be Fermions) of an homogeneous conductor can be calculated by summing up the Fermi-Dirac function $f_{\text{FD}}(\epsilon_i)$ over all states having energies ϵ_i [see Eq. (16.158)]

$$n(\mu) = \frac{1}{\mathcal{V}} \sum_i f_{\text{FD}}(\epsilon_i) = \frac{1}{\mathcal{V}} \sum_i \frac{1}{\exp[\beta(\epsilon_i - \mu)] + 1}, \quad (18.272)$$

where \mathcal{V} is the volume, $\beta^{-1} = k_{\text{B}}T$ is the thermal energy and where μ is the chemical potential. In the Thomas-Fermi approximation, which is valid provided that $\varphi(\mathbf{r})$ is a slowly varying function of position on the length scale of electron wavelength, the local value at location \mathbf{r} of charge carriers density is taken to be given by $n(\mu - q\varphi(\mathbf{r}))$. Thus, for small φ the induced charge density ρ_{ind} is approximately given by

$$\rho_{\text{ind}}(\mathbf{r}) = -q^2 \frac{\partial n}{\partial \mu} \varphi(\mathbf{r}). \quad (18.273)$$

When the thermal energy $k_B T$ is much smaller than the Fermi energy ϵ_F the factor $\partial n / \partial \mu$ is approximately the density of states at the Fermi energy ϵ_F , which is given by [see Eq. (16.104)]

$$\frac{\partial n}{\partial \mu} \simeq \frac{m^2 v_F}{\pi^2 \hbar^3}, \quad (18.274)$$

where v_F is the so-called Fermi velocity (which is defined by the relation $\partial \epsilon_{k'} / \partial k' = \hbar v_F$, where k' is the wave number and where the derivative is taken at $\epsilon_{k'} = \epsilon_F$). For this case Eq. (18.273) becomes

$$\rho_{\text{ind}}(\mathbf{r}) = -\frac{k_{\text{TF}}^2}{4\pi} \varphi(\mathbf{r}), \quad (18.275)$$

where

$$k_{\text{TF}}^2 = \frac{4\pi q^2 m^2 v_F}{\pi^2 \hbar^3}. \quad (18.276)$$

The above result (18.275) together with Eq. (18.271) yield

$$\epsilon(\mathbf{q}, 0) = 1 + \frac{k_{\text{TF}}^2}{|\mathbf{q}|^2}. \quad (18.277)$$

18.5.2 Two-Fluid Model

In the limit of vanishing temperature only superconducting charge carriers are present in a superconductor. However, at finite temperature also normally conducting charge carriers may be present. In the two-fluid model the total complex conductivity $\sigma(\omega)$ [see Eq. (18.263)] is taken to be given by

$$\sigma(\omega) = \sigma_n(\omega) + \sigma_s(\omega), \quad (18.278)$$

where both the normal contribution $\sigma_n(\omega)$ and the superconductivity one $\sigma_s(\omega)$ are evaluated using the Drude model expression (18.264).

As was discussed above, the first London equation for the homogeneous case (18.37) suggests that the resistance of superconductors vanishes. Accounting for this by taking the scattering time τ_{tr} to be effectively infinite yields [see (18.264)]

$$\sigma_s(\omega) = i \frac{q_s^{*2} n_s^*}{\omega m_s^*}. \quad (18.279)$$

For the case where normal conductance is carried by electrons having mass m_e , charge q_e , density n_e and scattering time $\tau_{\text{tr},e}$ the normal conductivity $\sigma_n(\omega)$ is given by [see (18.264)]

$$\sigma_n(\omega) = \frac{q_e^2 n_n \tau_{\text{tr},e}}{m_e} \frac{1}{1 - i\omega \tau_{\text{tr},e}}. \quad (18.280)$$

The dielectric constant $\epsilon(\omega)$ in the two fluid model is thus given by [see Eq. (18.268)]

$$\epsilon(\omega) = 1 + \frac{4\pi i \sigma_n(\omega)}{\omega} + \frac{4\pi i \sigma_s(\omega)}{\omega}, \quad (18.281)$$

or in terms of the skin depth δ_{sd} [see Eq. (18.269)] and the London penetration depth λ_L [see Eq. (18.26)]

$$\epsilon(\omega) = 1 + \frac{2i}{(\delta_{sd}k)^2} \frac{1}{1 - i\omega\tau_{tr,e}} - \frac{1}{(\lambda_L k)^2}, \quad (18.282)$$

where $k = \omega/c$. Note that $1/\delta_{sd}^2 \propto n_n$ [see Eq. (18.269)], whereas $1/\lambda_L^2 \propto n_s$ [see Eq. (18.26)]. Note also that the ratio between these characteristic length scales is given by

$$\frac{\lambda_L}{\delta_{sd}} = \sqrt{\frac{m_s^* n_e q_e^2 \omega \tau_{tr,e}}{m_e n_s^* q_s^{*2} 2}}. \quad (18.283)$$

18.5.3 Phonon Mediated Electron-Electron Interaction

The dielectric function in the zero frequency limit given by Eq. (18.277) represents the effect of screening by free charge carriers (i.e. by conducting electrons) of externally applied electric field. However, in the derivation of Eq. (18.277) the screening by localized charges (i.e. ions in the lattice) has not been taken into account.

The contribution of free charge carriers, which is denoted by ϵ_e , to the total dielectric function ϵ is given according to the Thomas-Fermi approximation by [see Eq. (18.277)]

$$\epsilon_e = 1 + \frac{k_{TF}^2}{|\mathbf{q}|^2}. \quad (18.284)$$

The contribution of localized charges (i.e. lattice vibrations), which is denoted by ϵ_i , is taken to be given by Eq. (18.267). When $\omega\tau_{tr,i} \gg 1$, where $\tau_{tr,i}$ is the effective scattering time of the localized charges, Eq. (18.267) yields

$$\epsilon_i = 1 - \frac{\omega_{p,i}^2}{\omega^2}, \quad (18.285)$$

where $\omega_{p,i}$, which is given by

$$\omega_{p,i}^2 = \frac{4\pi q_i^2 n_i}{m_i}, \quad (18.286)$$

is the ion plasma frequency and where m_i , q_i and n_i are the ionic mass, charge and density, respectively.

The total potential φ can be expressed as

$$\varphi = \varphi_{\text{ext}} + \varphi_e + \varphi_i, \quad (18.287)$$

where φ_e (φ_i) represents the contribution of free (localized) charges. The following is assumed to hold [see (18.251)]

$$\epsilon = \frac{\varphi_{\text{ext}}}{\varphi}, \quad (18.288)$$

$$\epsilon_e = \frac{\varphi_{\text{ext}} + \varphi_i}{\varphi}, \quad (18.289)$$

$$\epsilon_i = \frac{\varphi_{\text{ext}} + \varphi_e}{\varphi}, \quad (18.290)$$

and thus with the help of Eq. (18.287) one obtains

$$\epsilon = \epsilon_e + \epsilon_i - 1, \quad (18.291)$$

or [see Eqs. (18.284) and (18.285)]

$$\epsilon = 1 + \frac{k_{\text{TF}}^2}{|\mathbf{q}|^2} - \frac{\omega_{\text{p},i}^2}{\omega^2}. \quad (18.292)$$

The above result (18.292) indicates that the effect of lattice vibrations becomes important only when $\omega \lesssim \omega_{\text{p},i}$.

Let $\rho(\mathbf{r}')$ be the electron density in a medium having volume \mathcal{V} . Classically, the two-particle Coulomb interaction $V_{\text{TP}}(\mathbf{r}_1, \mathbf{r}_2) = e^2/|\mathbf{r}_1 - \mathbf{r}_2|$ [see Eq. (16.107)] gives rise to energy V given by [see Eqs. (16.66) and (16.44) for comparison with the analogous second-quantization expression]

$$V = \frac{1}{2} \int d^3\mathbf{r}' \int d^3\mathbf{r}'' V_{\text{TP}}(\mathbf{r}', \mathbf{r}'') \rho(\mathbf{r}') \rho(\mathbf{r}''). \quad (18.293)$$

With the help of the Fourier expansion

$$\rho(\mathbf{r}') = \frac{1}{(2\pi)^{3/2} \sqrt{\mathcal{V}}} \int d^3\mathbf{q}' \rho(\mathbf{q}') e^{i\mathbf{q}' \cdot \mathbf{r}'} \quad (18.294)$$

and Eqs. (4.47) and (16.136) one finds that [see Eq. (16.137) for comparison with the analogous second-quantization expression]

$$V = \frac{1}{2\mathcal{V}} \int d^3\mathbf{q} \frac{4\pi e^2}{|\mathbf{q}|^2} \rho(\mathbf{q}) \rho(-\mathbf{q}). \quad (18.295)$$

The effect of induced charges in the medium (i.e. screening) can be taken into account by dividing by the dielectric constant of the medium ϵ [see Eq. (18.251)]

$$V = \frac{1}{2\mathcal{V}} \int d^3\mathbf{q} \frac{4\pi e^2}{|\mathbf{q}|^2 \epsilon} \rho(\mathbf{q}) \rho(-\mathbf{q}) . \quad (18.296)$$

The expression for the Coulomb energy (18.296) together with the dielectric constant (18.292) lead to the effective interaction coefficient for a pair of electrons having wave vectors \mathbf{k}' and \mathbf{k}'' and energies $\epsilon_{k'}$ and $\epsilon_{k''}$ respectively

$$v_{\mathbf{k}',\mathbf{k}''} = \frac{4\pi e^2}{|\mathbf{q}|^2 \epsilon} = \frac{4\pi e^2}{|\mathbf{q}|^2 + k_{\text{TF}}^2} \frac{1}{1 - \frac{\Omega_{\text{p},i}^2}{\omega^2}} , \quad (18.297)$$

where

$$\mathbf{q} = \mathbf{k}'' - \mathbf{k}' , \quad (18.298)$$

$$\omega = \frac{\epsilon_{k''} - \epsilon_{k'}}{\hbar} , \quad (18.299)$$

and where

$$\Omega_{\text{p},i}^2 = \frac{|\mathbf{q}|^2}{|\mathbf{q}|^2 + k_{\text{TF}}^2} \omega_{\text{p},i}^2 . \quad (18.300)$$

The fact that ϵ^{-1} becomes negative when $\omega < \Omega_{\text{p},i}$ indicates that the effective (i.e. phonon mediated) electron-electron interaction becomes attractive in the limit of low frequencies. The characteristic energy interval $\hbar\Omega_{\text{p},i}$ in which the interaction becomes attractive is of the order of the so-called Debye energy ϵ_{D} , which represents the largest energy of an acoustic phonon in the lattice.

18.6 BCS Model

This chapter briefly discusses the BCS microscopic model of superconductivity.

18.6.1 The Hamiltonian

In the BCS model the Hamiltonian of electrons in a superconducting metal is taken to be given by

$$\begin{aligned} \mathcal{H} = & \sum_{\mathbf{k}'} (\epsilon_{k'} - \epsilon_{\text{F}}) \left(a_{\mathbf{k}',\uparrow}^\dagger a_{\mathbf{k}',\uparrow} + a_{\mathbf{k}',\downarrow}^\dagger a_{\mathbf{k}',\downarrow} \right) \\ & - \frac{g}{\mathcal{V}} \sum_{\mathbf{k}',\mathbf{k}''} \zeta_{\mathbf{k}'} \zeta_{\mathbf{k}''} B_{\mathbf{k}''}^\dagger B_{\mathbf{k}'} , \end{aligned} \quad (18.301)$$

where

$$B_{\mathbf{k}'} = a_{-\mathbf{k}',\downarrow} a_{\mathbf{k}',\uparrow} , \quad (18.302)$$

\uparrow labels spin up state, \downarrow labels spin down state, $\epsilon_{k'}$ is the energy of both single particle states $|\mathbf{k}', \uparrow\rangle$ and $|\mathbf{k}', \downarrow\rangle$, ϵ_F is the Fermi energy [see Eq. (16.102)] and

$$\zeta_{\mathbf{k}'} = \begin{cases} 1 & |\epsilon_{k'} - \epsilon_F| < \epsilon_D \\ 0 & \text{otherwise} \end{cases} . \quad (18.303)$$

The coupling constant $g > 0$ gives rise for an effective electron-electron attracting interaction [see Eq. (18.297)]. The interaction is assume to couple pairs of electrons whose energies are inside an energy interval of width $2\epsilon_D$ around the Fermi energy ϵ_F .

As can be seen from the comparison with the more general many-particle interaction operator V given by Eq. (16.94), the BCS Hamiltonian contains only interaction terms that represents annihilation (the factor $B_{\mathbf{k}'} = a_{-\mathbf{k}',\downarrow} a_{\mathbf{k}',\uparrow}$) and creation (the factor $B_{\mathbf{k}''}^\dagger = a_{\mathbf{k}'',\uparrow}^\dagger a_{-\mathbf{k}'',\downarrow}^\dagger$) of electrons pairs having zero total angular momentum. Moreover, the summation is restricted only to the energy interval of width $2\epsilon_D$ in which attractive interaction is expected, and the effective interaction coefficients are all assumed to be identical [see for comparison Eq. (18.297)].

18.6.2 Bogoliubov Transformation

Formally, the coupling term $B_{\mathbf{k}'',\mathbf{k}'}^\dagger B_{\mathbf{k}'}$ can be expressed as

$$\begin{aligned} B_{\mathbf{k}'',\mathbf{k}'}^\dagger B_{\mathbf{k}'} &= \left(B_{\mathbf{k}'',\mathbf{k}'}^\dagger - \langle B_{\mathbf{k}'',\mathbf{k}'}^\dagger \rangle \right) (B_{\mathbf{k}'} - \langle B_{\mathbf{k}'} \rangle) \\ &\quad + B_{\mathbf{k}'',\mathbf{k}'}^\dagger \langle B_{\mathbf{k}'} \rangle + \langle B_{\mathbf{k}'',\mathbf{k}'}^\dagger \rangle B_{\mathbf{k}'} - \langle B_{\mathbf{k}'',\mathbf{k}'}^\dagger \rangle \langle B_{\mathbf{k}'} \rangle , \end{aligned} \quad (18.304)$$

where $\langle B_{\mathbf{k}'} \rangle$ is the expectation value of $B_{\mathbf{k}'}$ in thermal equilibrium. In the mean field approximation the term $B_{\mathbf{k}'',\mathbf{k}'}^\dagger - \langle B_{\mathbf{k}'',\mathbf{k}'}^\dagger \rangle$, which represents the deviation from the expectation value, is considered as small, and consequently the first term in Eq. (18.304) is disregarded. The Hamiltonian can be further simplified by removing all constant terms (such terms do not affect the dynamics of the system). To that end also the last term in Eq. (18.304) can be disregarded. This approach leads to the mean field Hamiltonian \mathcal{H}_{MF} , which is found to be given by

$$\begin{aligned} \mathcal{H}_{\text{MF}} &= \sum_{\mathbf{k}'} (\epsilon_{k'} - \epsilon_F) \left(a_{\mathbf{k}',\uparrow}^\dagger a_{\mathbf{k}',\uparrow} - a_{\mathbf{k}',\downarrow} a_{\mathbf{k}',\downarrow}^\dagger \right) \\ &\quad - \Delta \sum_{\mathbf{k}'} \zeta_{\mathbf{k}'} B_{\mathbf{k}'}^\dagger - \Delta^* \sum_{\mathbf{k}'} \zeta_{\mathbf{k}'} B_{\mathbf{k}'} , \end{aligned} \quad (18.305)$$

where

$$\Delta = \frac{g}{V} \sum_{\mathbf{k}'} \zeta_{\mathbf{k}'} \langle B_{\mathbf{k}'} \rangle . \quad (18.306)$$

Note that the identity $a_{\mathbf{k}',\downarrow}^\dagger a_{\mathbf{k}',\downarrow} = 1 - a_{\mathbf{k}',\downarrow} a_{\mathbf{k}',\downarrow}^\dagger$ has been employed to derive the first term of \mathcal{H}_{MF} (and the resultant constant term $\sum_{\mathbf{k}'} (\epsilon_{\mathbf{k}'} - \epsilon_{\text{F}})$ has been removed).

By introducing the spinor operator $\Upsilon_{\mathbf{k}'}$, which is given by

$$\Upsilon_{\mathbf{k}'} = \begin{pmatrix} a_{\mathbf{k}',\uparrow} \\ a_{-\mathbf{k}',\downarrow}^\dagger \end{pmatrix} , \quad (18.307)$$

one finds that \mathcal{H}_{MF} can be expressed as

$$\mathcal{H}_{\text{MF}} = \sum_{\mathbf{k}'} \Upsilon_{\mathbf{k}'}^\dagger M_{\mathbf{k}'} \Upsilon_{\mathbf{k}'} , \quad (18.308)$$

where

$$M_{\mathbf{k}'} = \begin{pmatrix} \epsilon_{\mathbf{k}'} - \epsilon_{\text{F}} & -\Delta \zeta_{\mathbf{k}'} \\ -\Delta^* \zeta_{\mathbf{k}'} & -(\epsilon_{\mathbf{k}'} - \epsilon_{\text{F}}) \end{pmatrix} , \quad (18.309)$$

and where $\Upsilon_{\mathbf{k}'}^\dagger = (a_{\mathbf{k}',\uparrow}^\dagger \ a_{-\mathbf{k}',\downarrow})$.

For the case where $\zeta_{\mathbf{k}'} \neq 0$ the matrix $M_{\mathbf{k}'}$ can be diagonalized using the Bogoliubov transformation [see Eqs. (16.112), (16.164) and (16.165)]. Alternatively, Eqs. (6.301) and (6.302) can be employed for the same task. For the case where $\zeta_{\mathbf{k}'} = 1$ the matrix $M_{\mathbf{k}'}$ can be expressed as

$$M_{\mathbf{k}'} = \eta_{\mathbf{k}'} \begin{pmatrix} \cos(2\theta_{\mathbf{k}'}) & \sin(2\theta_{\mathbf{k}'}) e^{-2i\phi_\Delta} \\ \sin(2\theta_{\mathbf{k}'}) e^{2i\phi_\Delta} & -\cos(2\theta_{\mathbf{k}'}) \end{pmatrix} , \quad (18.310)$$

where

$$\eta_{\mathbf{k}'} = \sqrt{(\epsilon_{\mathbf{k}'} - \epsilon_{\text{F}})^2 + |\Delta|^2} , \quad (18.311)$$

$$\Delta = |\Delta| e^{-2i\phi_\Delta} , \quad (18.312)$$

$$\theta_{\mathbf{k}'} = \frac{1}{2} \tan^{-1} \left(-\frac{|\Delta|}{\epsilon_{\mathbf{k}'} - \epsilon_{\text{F}}} \right) , \quad (18.313)$$

and where both ϕ_Δ and $\theta_{\mathbf{k}'}$ are real. The following holds [see Eqs. (6.301) and (6.302)]

$$U_{\mathbf{k}'}^{-1} M_{\mathbf{k}'} U_{\mathbf{k}'} = \eta_{\mathbf{k}'} \begin{pmatrix} 1 & 0 \\ 0 & -1 \end{pmatrix} , \quad (18.314)$$

where the unitary matrix $U_{\mathbf{k}'}$ is given by

$$U_{\mathbf{k}'} = \begin{pmatrix} \cos \theta_{\mathbf{k}'} e^{-i\phi_\Delta} & -\sin \theta_{\mathbf{k}'} e^{-i\phi_\Delta} \\ \sin \theta_{\mathbf{k}'} e^{i\phi_\Delta} & \cos \theta_{\mathbf{k}'} e^{i\phi_\Delta} \end{pmatrix} , \quad (18.315)$$

and thus the Hamiltonian \mathcal{H}_{MF} (18.308) can be expressed as

$$\begin{aligned}\mathcal{H}_{\text{MF}} &= \sum_{\mathbf{k}'} \eta_{\mathbf{k}'} \begin{pmatrix} b_{\mathbf{k}',\uparrow}^\dagger & b_{-\mathbf{k}',\downarrow} \end{pmatrix} \begin{pmatrix} 1 & 0 \\ 0 & -1 \end{pmatrix} \begin{pmatrix} b_{\mathbf{k}',\uparrow} \\ b_{-\mathbf{k}',\downarrow}^\dagger \end{pmatrix} \\ &= \sum_{\mathbf{k}'} \eta_{\mathbf{k}'} \left(b_{\mathbf{k}',\uparrow}^\dagger b_{\mathbf{k}',\uparrow} - b_{-\mathbf{k}',\downarrow} b_{-\mathbf{k}',\downarrow}^\dagger \right),\end{aligned}\tag{18.316}$$

where

$$\begin{pmatrix} b_{\mathbf{k}',\uparrow} \\ b_{-\mathbf{k}',\downarrow}^\dagger \end{pmatrix} = U_{\mathbf{k}'}^{-1} \begin{pmatrix} a_{\mathbf{k}',\uparrow} \\ a_{-\mathbf{k}',\downarrow}^\dagger \end{pmatrix}.\tag{18.317}$$

By using the relation $-b_{-\mathbf{k}',\downarrow} b_{-\mathbf{k}',\downarrow}^\dagger = b_{-\mathbf{k}',\downarrow}^\dagger b_{-\mathbf{k}',\downarrow} - 1$ and removing the constant term $-\sum_{\mathbf{k}'} \eta_{\mathbf{k}'}$ the Hamiltonian \mathcal{H}_{MF} becomes

$$\mathcal{H}_{\text{MF}} = \sum_{\mathbf{k}',\sigma} \eta_{\mathbf{k}'} N_{\mathbf{k}',\sigma},\tag{18.318}$$

where $\sigma \in \{\uparrow, \downarrow\}$ and the number operator $N_{\mathbf{k},\sigma}$ (with respect to the $b_{\mathbf{k},\sigma}$ and $b_{\mathbf{k},\sigma}^\dagger$ operators) is given by

$$N_{\mathbf{k},\sigma} = b_{\mathbf{k},\sigma}^\dagger b_{\mathbf{k},\sigma}.\tag{18.319}$$

Exercise 18.6.1. Show that the annihilation $b_{\mathbf{k},\sigma}$ and creation $b_{\mathbf{k},\sigma}^\dagger$ operators satisfy Fermionic commutation relations.

Solution 18.6.1. It is convenient to introduce the compact notation for general A , B , C and D operators

$$\left[\begin{pmatrix} A \\ B \end{pmatrix}, (C \ D) \right]_+ = \begin{pmatrix} [A, C]_+ & [A, D]_+ \\ [B, C]_+ & [B, D]_+ \end{pmatrix}.\tag{18.320}$$

The following holds [see Eqs. (16.8), (16.9), (18.307) and (18.320)]

$$\begin{aligned}\left[\Upsilon_{\mathbf{k}'}, \Upsilon_{\mathbf{k}'}^\dagger \right]_+ &= \left[\begin{pmatrix} a_{\mathbf{k}',\uparrow} \\ a_{-\mathbf{k}',\downarrow}^\dagger \end{pmatrix}, \begin{pmatrix} a_{\mathbf{k}',\uparrow}^\dagger & a_{-\mathbf{k}',\downarrow} \end{pmatrix} \right]_+ \\ &= \begin{pmatrix} \left[a_{\mathbf{k}',\uparrow}, a_{\mathbf{k}',\uparrow}^\dagger \right]_+ & \left[a_{\mathbf{k}',\uparrow}, a_{-\mathbf{k}',\downarrow} \right]_+ \\ \left[a_{-\mathbf{k}',\downarrow}^\dagger, a_{\mathbf{k}',\uparrow}^\dagger \right]_+ & \left[a_{-\mathbf{k}',\downarrow}^\dagger, a_{-\mathbf{k}',\downarrow} \right]_+ \end{pmatrix} \\ &= \begin{pmatrix} 1 & 0 \\ 0 & 1 \end{pmatrix}.\end{aligned}\tag{18.321}$$

Using the notation

$$\Xi = \begin{pmatrix} b_{\mathbf{k}',\uparrow} \\ b_{-\mathbf{k}',\downarrow}^\dagger \end{pmatrix}, \quad (18.322)$$

Eq. (18.317) can be rewriting as

$$\Xi = U_{\mathbf{k}'}^{-1} \Upsilon_{\mathbf{k}'}, \quad (18.323)$$

and the following holds

$$[\Xi, \Xi^\dagger]_+ = \begin{pmatrix} [b_{\mathbf{k}',\uparrow}, b_{\mathbf{k}',\uparrow}^\dagger]_+ & [b_{\mathbf{k}',\uparrow}, b_{-\mathbf{k}',\downarrow}]_+ \\ [b_{-\mathbf{k}',\downarrow}^\dagger, b_{\mathbf{k}',\uparrow}^\dagger]_+ & [b_{-\mathbf{k}',\downarrow}^\dagger, b_{-\mathbf{k}',\downarrow}]_+ \end{pmatrix}, \quad (18.324)$$

and

$$[\Xi, \Xi^\dagger]_+ = [U_{\mathbf{k}'}^{-1} \Upsilon_{\mathbf{k}'}, \Upsilon_{\mathbf{k}'}^\dagger U_{\mathbf{k}'}]_+ = U_{\mathbf{k}'}^{-1} [\Upsilon_{\mathbf{k}'}, \Upsilon_{\mathbf{k}'}^\dagger]_+ U_{\mathbf{k}'}, \quad (18.325)$$

hence

$$\begin{pmatrix} [b_{\mathbf{k}',\uparrow}, b_{\mathbf{k}',\uparrow}^\dagger]_+ & [b_{\mathbf{k}',\uparrow}, b_{-\mathbf{k}',\downarrow}]_+ \\ [b_{-\mathbf{k}',\downarrow}^\dagger, b_{\mathbf{k}',\uparrow}^\dagger]_+ & [b_{-\mathbf{k}',\downarrow}^\dagger, b_{-\mathbf{k}',\downarrow}]_+ \end{pmatrix} = \begin{pmatrix} 1 & 0 \\ 0 & 1 \end{pmatrix}. \quad (18.326)$$

Note that the Hamiltonian \mathcal{H}_{MF} (18.318) is simplified by summing over all values of \mathbf{k}' , rather than restricting the sum over the spherical shell inside which $\zeta_{\mathbf{k}'} = 1$ [see Eq. (18.303)]. This simplifying assumption can be justified provided that $|\Delta| \ll \epsilon_{\text{D}}$, since for that case and outside the spherical shell, i.e. when $|\epsilon_{\mathbf{k}'} - \epsilon_{\text{F}}| > \epsilon_{\text{D}}$, one has $\eta_{\mathbf{k}'} \simeq \epsilon_{\mathbf{k}'} - \epsilon_{\text{F}}$ [see Eq. (18.311)], namely $\eta_{\mathbf{k}'}$ becomes very close to the energy in the normal state. As can be seen from Eq. (18.342) below, the condition $|\Delta| \ll \epsilon_{\text{D}}$ is expected to be satisfied provided that $gD_0 \ll 1$.

Some useful relations are listed below

$$\begin{aligned} a_{\mathbf{k},\uparrow}^\dagger a_{\mathbf{k},\uparrow} &= \sin^2 \theta_{\mathbf{k}} (1 - N_{-\mathbf{k},\downarrow}) + \cos^2 \theta_{\mathbf{k}} N_{\mathbf{k},\uparrow} \\ &\quad + \frac{\sin(2\theta_{\mathbf{k}})}{2} (b_{\mathbf{k},\uparrow} b_{-\mathbf{k},\downarrow} + b_{-\mathbf{k},\downarrow}^\dagger b_{\mathbf{k},\uparrow}^\dagger), \end{aligned} \quad (18.327)$$

$$\begin{aligned} a_{-\mathbf{k},\downarrow}^\dagger a_{-\mathbf{k},\downarrow} &= \sin^2 \theta_{\mathbf{k}} (1 - N_{\mathbf{k},\uparrow}) + \cos^2 \theta_{\mathbf{k}} N_{-\mathbf{k},\downarrow} \\ &\quad + \frac{\sin(2\theta_{\mathbf{k}})}{2} (b_{\mathbf{k},\uparrow} b_{-\mathbf{k},\downarrow} + b_{-\mathbf{k},\downarrow}^\dagger b_{\mathbf{k},\uparrow}^\dagger), \end{aligned} \quad (18.328)$$

$$\begin{aligned} B_{\mathbf{k}'} &= \frac{e^{-2i\phi_\Delta} \sin(2\theta_{\mathbf{k}'})}{2} (N_{-\mathbf{k}',\downarrow} + N_{\mathbf{k}',\uparrow} - 1) \\ &\quad + e^{-2i\phi_\Delta} \left(\sin^2 \theta_{\mathbf{k}'} b_{-\mathbf{k}',\downarrow}^\dagger b_{\mathbf{k}',\uparrow}^\dagger - \cos^2 \theta_{\mathbf{k}'} b_{\mathbf{k}',\uparrow} b_{-\mathbf{k}',\downarrow} \right). \end{aligned} \quad (18.329)$$

$$\sin(2\theta_{\mathbf{k}'}) = -\frac{|\Delta|}{\sqrt{(\epsilon_{\mathbf{k}'} - \epsilon_{\text{F}})^2 + |\Delta|^2}}, \quad (18.330)$$

$$\cos(2\theta_{\mathbf{k}'}) = \frac{\epsilon_{\mathbf{k}'} - \epsilon_{\text{F}}}{\sqrt{(\epsilon_{\mathbf{k}'} - \epsilon_{\text{F}})^2 + |\Delta|^2}}, \quad (18.331)$$

and

$$\sin(\theta_{\mathbf{k}'}) = \sqrt{\frac{1 - \frac{\epsilon_{\mathbf{k}'} - \epsilon_{\text{F}}}{\sqrt{(\epsilon_{\mathbf{k}'} - \epsilon_{\text{F}})^2 + |\Delta|^2}}}{2}}, \quad (18.332)$$

$$\cos(\theta_{\mathbf{k}'}) = \sqrt{\frac{1 + \frac{\epsilon_{\mathbf{k}'} - \epsilon_{\text{F}}}{\sqrt{(\epsilon_{\mathbf{k}'} - \epsilon_{\text{F}})^2 + |\Delta|^2}}}{2}}. \quad (18.333)$$

Consider the limit $|\Delta| \rightarrow 0$ (normal conductance limit). In this limit, $\theta_{\mathbf{k}'} \rightarrow 0$ ($\theta_{\mathbf{k}'} \rightarrow \pi/2$) for the case $\epsilon_{\mathbf{k}'} > \epsilon_{\text{F}}$ ($\epsilon_{\mathbf{k}'} < \epsilon_{\text{F}}$), and thus $b_{-\mathbf{k}',\downarrow}^\dagger \rightarrow e^{-i\phi\Delta} a_{-\mathbf{k}',\downarrow}^\dagger$ ($b_{-\mathbf{k}',\downarrow}^\dagger \rightarrow -e^{i\phi\Delta} a_{\mathbf{k}',\uparrow}$) [see Eqs. (18.317), (18.332) and (18.333)]. Hence, the elementary excitation is electron creation (electron annihilation, i.e. hole creation) above (below) the Fermi energy ϵ_{F} .

18.6.3 The Energy Gap

The value of the energy gap $|\Delta|$ can be determined from Eq. (18.306). Let $n_{\mathbf{k}',\sigma}$ denotes the expectation value of the operator $N_{\mathbf{k}',\sigma}$, i.e.

$$\langle N_{\mathbf{k}',\sigma} \rangle = n_{\mathbf{k}',\sigma}. \quad (18.334)$$

In thermal equilibrium at temperature T the following holds [see Eqs. (16.155), (16.156), (18.318) and (18.311)]

$$n_{\mathbf{k}',\sigma} = \frac{1}{e^{\beta\eta_{\mathbf{k}'}} + 1}, \quad (18.335)$$

where $\beta = 1/(k_{\text{B}}T)$, and where k_{B} is Boltzmann's constant. Moreover, in thermal equilibrium $\langle b_{-\mathbf{k}',\downarrow}^\dagger b_{\mathbf{k}',\uparrow}^\dagger \rangle = \langle b_{\mathbf{k}',\uparrow} b_{-\mathbf{k}',\downarrow} \rangle = 0$ and thus $\langle B_{\mathbf{k}'} \rangle$ is given by [see Eq. (18.329) and recall that $|\Delta| = \Delta e^{2i\phi\Delta}$]

$$\langle B_{\mathbf{k}'} \rangle = \frac{\Delta(1 - n_{-\mathbf{k}',\downarrow} - n_{\mathbf{k}',\uparrow})}{2\sqrt{(\epsilon_{\mathbf{k}'} - \epsilon_{\text{F}})^2 + |\Delta|^2}}, \quad (18.336)$$

and thus Eq. (18.306) can be expressed as

$$1 = \frac{g}{2\mathcal{V}} \sum_{\mathbf{k}'}^{\epsilon_{\text{F}} - \epsilon_{\text{D}} < \epsilon_{\mathbf{k}'} < \epsilon_{\text{F}} + \epsilon_{\text{D}}} \frac{1 - n_{-\mathbf{k}',\downarrow} - n_{\mathbf{k}',\uparrow}}{\sqrt{(\epsilon_{\mathbf{k}'} - \epsilon_{\text{F}})^2 + |\Delta|^2}}, \quad (18.337)$$

or [see Eqs. (18.311) and (18.335)]

$$\begin{aligned}
 1 &= \frac{g}{2\mathcal{V}} \sum_{\mathbf{k}'}^{\epsilon_F - \epsilon_D < \epsilon_{\mathbf{k}'} < \epsilon_F + \epsilon_D} \frac{1 - 2(e^{\beta\eta_{\mathbf{k}'}} + 1)^{-1}}{\eta_{\mathbf{k}'}} \\
 &= \frac{g}{2\mathcal{V}} \sum_{\mathbf{k}'}^{\epsilon_F - \epsilon_D < \epsilon_{\mathbf{k}'} < \epsilon_F + \epsilon_D} \frac{\tanh\left(\frac{\beta\eta_{\mathbf{k}'}}{2}\right)}{\eta_{\mathbf{k}'}}.
 \end{aligned} \tag{18.338}$$

Replacing the sum by an integral leads to

$$1 = \frac{gD_0}{2} \int_{-\epsilon_D}^{\epsilon_D} d\epsilon' \frac{\tanh\frac{\beta\sqrt{\epsilon'^2 + |\Delta|^2}}{2}}{\sqrt{\epsilon'^2 + |\Delta|^2}}, \tag{18.339}$$

where D_0 is the density of states per unit volume.

Zero Temperature. For the case of zero temperature, where all occupation numbers vanish, i.e. $n_{\mathbf{k}',\sigma} = 0$, Eq. (18.339) becomes

$$\begin{aligned}
 1 &= \frac{gD_0}{2} \int_{-\epsilon_D}^{\epsilon_D} \frac{d\epsilon'}{\sqrt{\epsilon'^2 + \Delta_0^2}} \\
 &= \frac{gD_0}{2} \log \frac{\epsilon_D + \sqrt{\epsilon_D^2 + \Delta_0^2}}{-\epsilon_D + \sqrt{\epsilon_D^2 + \Delta_0^2}},
 \end{aligned} \tag{18.340}$$

where Δ_0 stands for the value of $|\Delta|$ at zero temperature. The assumption $\Delta_0 \ll \epsilon_D$ leads to

$$1 = \frac{gD_0}{2} \log \frac{4\epsilon_D^2}{\Delta_0^2}, \tag{18.341}$$

thus

$$\Delta_0 = 2\epsilon_D \exp\left(-\frac{1}{gD_0}\right). \tag{18.342}$$

Critical Temperature. The energy gap $|\Delta|$ vanishes when $T = T_c$, where T_c is the critical temperature. For this case Eq. (18.339) becomes

$$\begin{aligned}
 1 &= \frac{gD_0}{2} \int_{-\epsilon_D}^{\epsilon_D} d\epsilon' \frac{\tanh\frac{\beta_c \epsilon'}{2}}{\epsilon'} \\
 &= gD_0 \int_0^{\frac{\beta_c \epsilon_D}{2}} dx \frac{\tanh x}{x},
 \end{aligned} \tag{18.343}$$

where $\beta_c = 1/k_B T_c$. Integration by parts (note that $\lim_{x \rightarrow 0} \tanh x \log x = 0$) yields

$$1 = gD_0 \left(\tanh \frac{\beta_c \epsilon_D}{2} \log \frac{\beta_c \epsilon_D}{2} - \int_0^{\frac{\beta_c \epsilon_D}{2}} dx \frac{\log x}{\cosh^2 x} \right). \quad (18.344)$$

For the case of weak coupling, for which

$$\frac{\beta_c \epsilon_D}{2} \gg 1, \quad (18.345)$$

one has

$$1 \simeq gD_0 \left(\log \frac{\beta_c \epsilon_D}{2} - \int_0^\infty dx \frac{\log x}{\cosh^2 x} \right). \quad (18.346)$$

Using the identity

$$- \int_0^\infty dx \frac{\log x}{\cosh^2 x} = \log \frac{4}{\pi} + C_E, \quad (18.347)$$

where $C_E \simeq 0.577$ is Euler's constant, one finds that [see Eq. (18.342)]

$$k_B T_c = \frac{e^{C_E}}{\pi} \Delta_0 \simeq 0.566 \times \Delta_0. \quad (18.348)$$

General Temperature. The energy gap $|\Delta|$ at temperature T can be numerically evaluated from Eq. (18.339). To a good approximation the solution can be expressed by the following analytical relation

$$|\Delta| \simeq \Delta_0 \sqrt{1 - \left(\frac{T}{T_c} \right)^3}. \quad (18.349)$$

18.6.4 The Ground State

The ground state $|\Psi_0\rangle$ of the mean field Hamiltonian $\mathcal{H}_{\text{MF}} = \sum_{\mathbf{k}', \sigma} \eta_{\mathbf{k}'} N_{\mathbf{k}', \sigma}$ (18.318) is a state for which all occupation numbers vanish, i.e. $N_{\mathbf{k}', \sigma} |\Psi_0\rangle = b_{\mathbf{k}, \sigma}^\dagger b_{\mathbf{k}, \sigma} |\Psi_0\rangle = 0$, and therefore $b_{\mathbf{k}, \sigma} |\Psi_0\rangle = 0$ for all \mathbf{k} and σ . Moreover, $|\Psi_0\rangle$ is required to be normalized, i.e. $\langle \Psi_0 | \Psi_0 \rangle = 1$.

Claim. The ground state $|\Psi_0\rangle$ is given by

$$|\Psi_0\rangle = \prod_{\mathbf{k}'} \mathcal{K}_{\mathbf{k}'} |0\rangle, \quad (18.350)$$

where

$$\mathcal{K}_{\mathbf{k}'} = e^{i\phi_\Delta} \cos \theta_{\mathbf{k}'} - e^{-i\phi_\Delta} \sin \theta_{\mathbf{k}'} a_{\mathbf{k}', \uparrow}^\dagger a_{-\mathbf{k}', \downarrow}^\dagger. \quad (18.351)$$

Proof. By employing the fact that $[\mathcal{K}_{\mathbf{k}''}^\dagger, \mathcal{K}_{\mathbf{k}'}] = 0$ provided that $\mathbf{k}' \neq \mathbf{k}''$ and the relation

$$\begin{aligned} \mathcal{K}_{\mathbf{k}'}^\dagger \mathcal{K}_{\mathbf{k}'} &= \cos^2 \theta_{\mathbf{k}'} + \sin^2 \theta_{\mathbf{k}'} a_{-\mathbf{k}', \downarrow} a_{\mathbf{k}', \uparrow} a_{\mathbf{k}', \uparrow}^\dagger a_{-\mathbf{k}', \downarrow}^\dagger \\ &\quad - \sin \theta_{\mathbf{k}'} \cos \theta_{\mathbf{k}'} \left(e^{-2i\phi_\Delta} a_{\mathbf{k}', \uparrow}^\dagger a_{-\mathbf{k}', \downarrow}^\dagger + e^{2i\phi_\Delta} a_{-\mathbf{k}', \downarrow} a_{\mathbf{k}', \uparrow} \right), \end{aligned} \quad (18.352)$$

one finds that $|\Psi_0\rangle$ is indeed normalized as required

$$\begin{aligned} \langle \Psi_0 | \Psi_0 \rangle &= \langle 0 | \prod_{\mathbf{k}''} \mathcal{K}_{\mathbf{k}''}^\dagger \prod_{\mathbf{k}'} \mathcal{K}_{\mathbf{k}'} | 0 \rangle \\ &= \langle 0 | \prod_{\mathbf{k}'} \mathcal{K}_{\mathbf{k}'}^\dagger \mathcal{K}_{\mathbf{k}'} | 0 \rangle \\ &= \langle 0 | \prod_{\mathbf{k}'} \left[\cos^2 \theta_{\mathbf{k}'} + \sin^2 \theta_{\mathbf{k}'} \left(1 - a_{\mathbf{k}', \uparrow}^\dagger a_{\mathbf{k}', \uparrow} \right) \left(1 - a_{-\mathbf{k}', \downarrow}^\dagger a_{-\mathbf{k}', \downarrow} \right) \right] | 0 \rangle \\ &= 1. \end{aligned} \quad (18.353)$$

Moreover, using the relations [see Eq. (18.317)]

$$\begin{aligned} b_{\mathbf{k}', \uparrow} \mathcal{K}_{\mathbf{k}'} &= \left(e^{i\phi_\Delta} \cos \theta_{\mathbf{k}'} a_{\mathbf{k}', \uparrow} - e^{-i\phi_\Delta} \sin \theta_{\mathbf{k}'} a_{-\mathbf{k}', \downarrow}^\dagger \right) \\ &\quad \times \left(e^{i\phi_\Delta} \cos \theta_{\mathbf{k}'} - e^{-i\phi_\Delta} \sin \theta_{\mathbf{k}'} a_{\mathbf{k}', \uparrow}^\dagger a_{-\mathbf{k}', \downarrow}^\dagger \right), \end{aligned} \quad (18.354)$$

and

$$\begin{aligned} b_{-\mathbf{k}, \downarrow} \mathcal{K}_{\mathbf{k}'} &= \left(e^{i\phi_\Delta} \cos \theta_{\mathbf{k}'} a_{-\mathbf{k}', \downarrow} - e^{-i\phi_\Delta} \sin \theta_{\mathbf{k}'} a_{\mathbf{k}', \uparrow}^\dagger \right) \\ &\quad \times \left(e^{i\phi_\Delta} \cos \theta_{\mathbf{k}'} - e^{-i\phi_\Delta} \sin \theta_{\mathbf{k}'} a_{\mathbf{k}', \uparrow}^\dagger a_{-\mathbf{k}', \downarrow}^\dagger \right), \end{aligned} \quad (18.355)$$

one finds that

$$\begin{aligned} b_{\mathbf{k}', \uparrow} |\Psi_0\rangle &= b_{\mathbf{k}', \uparrow} \prod_{\mathbf{k}''} \mathcal{K}_{\mathbf{k}''} | 0 \rangle \\ &= \left(\prod_{\mathbf{k}'' \neq \mathbf{k}'} \mathcal{K}_{\mathbf{k}''} \right) b_{\mathbf{k}', \uparrow} \mathcal{K}_{\mathbf{k}'} | 0 \rangle \\ &= - \left(\prod_{\mathbf{k}'' \neq \mathbf{k}'} \mathcal{K}_{\mathbf{k}''} \right) \sin \theta_{\mathbf{k}'} \cos \theta_{\mathbf{k}'} \left(a_{\mathbf{k}', \uparrow} a_{\mathbf{k}', \uparrow}^\dagger + 1 \right) a_{-\mathbf{k}', \downarrow}^\dagger | 0 \rangle \\ &= \left(\prod_{\mathbf{k}'' \neq \mathbf{k}'} \mathcal{K}_{\mathbf{k}''} \right) \sin \theta_{\mathbf{k}'} \cos \theta_{\mathbf{k}'} a_{\mathbf{k}', \uparrow}^\dagger a_{\mathbf{k}', \uparrow} a_{-\mathbf{k}', \downarrow}^\dagger | 0 \rangle \\ &= 0, \end{aligned} \quad (18.356)$$

and similarly

$$b_{-\mathbf{k},\downarrow} |\Psi_0\rangle = 0 .$$

Alternatively, the ground state $|\Psi_0\rangle$, which is given by Eq. (18.350), can be expressed as

$$|\Psi_0\rangle = C_0 \prod_{\mathbf{k}'} \left(1 - \gamma_{\mathbf{k}'} a_{\mathbf{k}',\uparrow}^\dagger a_{-\mathbf{k}',\downarrow}^\dagger \right) |0\rangle , \quad (18.357)$$

where C_0 is a normalization constant, which is given by

$$C_0 = \prod_{\mathbf{k}'} e^{i\phi_\Delta} \cos \theta_{\mathbf{k}'} , \quad (18.358)$$

and where [see Eqs. (18.332) and (18.333)]

$$\begin{aligned} \gamma_{\mathbf{k}'} &= e^{-2i\phi_\Delta} \tan \theta_{\mathbf{k}'} \\ &= e^{-2i\phi_\Delta} \sqrt{\frac{1 - \frac{\epsilon_{\mathbf{k}'} - \epsilon_F}{\sqrt{(\epsilon_{\mathbf{k}'} - \epsilon_F)^2 + |\Delta|^2}}}{1 + \frac{\epsilon_{\mathbf{k}'} - \epsilon_F}{\sqrt{(\epsilon_{\mathbf{k}'} - \epsilon_F)^2 + |\Delta|^2}}}} . \end{aligned} \quad (18.359)$$

Furthermore, since $\left(a_{\mathbf{k}',\uparrow}^\dagger a_{-\mathbf{k}',\downarrow}^\dagger \right)^2 = 0$ the following holds

$$|\Psi_0\rangle = C_0 \exp \left(- \sum_{\mathbf{k}'} \gamma_{\mathbf{k}'} a_{\mathbf{k}',\uparrow}^\dagger a_{-\mathbf{k}',\downarrow}^\dagger \right) |0\rangle . \quad (18.360)$$

18.6.5 Pairing Wavefunction

For a general function of position $\gamma(\mathbf{r}''')$ the following holds

$$\begin{aligned} & \int d\mathbf{r}' \int d\mathbf{r}'' \gamma(\mathbf{r}'' - \mathbf{r}') \Psi_\uparrow^\dagger(\mathbf{r}') \Psi_\uparrow^\dagger(\mathbf{r}'') \\ &= \frac{1}{\mathcal{V}} \sum_{\mathbf{k}', \mathbf{k}''} a_{\mathbf{k}',\uparrow}^\dagger a_{-\mathbf{k}'',\downarrow}^\dagger \int d\mathbf{r}' \int d\mathbf{r}'' \gamma(\mathbf{r}'' - \mathbf{r}') e^{i\mathbf{k}'' \cdot \mathbf{r}'' - i\mathbf{k}' \cdot \mathbf{r}'} \\ &= \sum_{\mathbf{k}', \mathbf{k}''} a_{\mathbf{k}',\uparrow}^\dagger a_{-\mathbf{k}'',\downarrow}^\dagger \underbrace{\frac{1}{\mathcal{V}} \int d\mathbf{r}' e^{i(\mathbf{k}'' - \mathbf{k}') \cdot \mathbf{r}'}}_{=\delta_{\mathbf{k}', \mathbf{k}''}} \int d\mathbf{r}''' \gamma(\mathbf{r}''') e^{i\mathbf{k}' \cdot \mathbf{r}'''} \\ &= \sum_{\mathbf{k}'} a_{\mathbf{k}',\uparrow}^\dagger a_{-\mathbf{k}',\downarrow}^\dagger \int d\mathbf{r}''' \gamma(\mathbf{r}''') e^{i\mathbf{k}' \cdot \mathbf{r}'''} , \end{aligned} \quad (18.361)$$

where $\Psi_\sigma(\mathbf{r}')$ is quantized field operators [see Eq. (16.97)]. In view of the above result the ground state $|\Psi_0\rangle$, which is given by Eq. (18.360), can be expressed as

$$|\Psi_0\rangle = C_0 \exp\left(\int d\mathbf{r}' \int d\mathbf{r}'' \gamma(\mathbf{r}'' - \mathbf{r}') \Psi_\uparrow^\dagger(\mathbf{r}') \Psi_\downarrow^\dagger(\mathbf{r}'')\right) |0\rangle, \quad (18.362)$$

where the function $\gamma(\mathbf{r}'' - \mathbf{r}')$, which is called the pairing wavefunction, satisfies

$$\int d\mathbf{r}''' \gamma(\mathbf{r}''') e^{i\mathbf{k}' \cdot \mathbf{r}'''} = -\gamma_{\mathbf{k}'}, \quad (18.363)$$

where $\gamma_{\mathbf{k}'}$ is given by Eq. (18.359).

The energy region near ϵ_F in which $\gamma_{\mathbf{k}'}$ changes significantly has a characteristic width given by the energy gap Δ_0 [see Eq. (18.359)]. The corresponding region in \mathbf{k}' space has thus a characteristic size given by $\Delta_0/\hbar v_F$, where v_F is the so-called Fermi velocity (which is defined by the relation $\partial\epsilon_{\mathbf{k}'}/\partial k' = \hbar v_F$, where the derivative is taken at $\epsilon_{\mathbf{k}'} = \epsilon_F$). Consequently the pairing wavefunction $\gamma(\mathbf{r}''')$ is expected to have a characteristic 'size' given by ξ , where

$$\xi = \frac{\hbar v_F}{\pi |\Delta|}, \quad (18.364)$$

is the so-called BCS coherence length.

18.7 The Josephson Effect

Consider the global transformation $a_{\mathbf{k}',\sigma} \rightarrow a_{\mathbf{k}',\sigma} e^{-i\Theta/2}$ and $a_{\mathbf{k}',\sigma}^\dagger \rightarrow a_{\mathbf{k}',\sigma}^\dagger e^{i\Theta/2}$, where Θ is real. Such a transformation leaves the Hamiltonian (18.301) unchanged, however, the factor $B_{\mathbf{k}'}$ is transformed according to $B_{\mathbf{k}'} \rightarrow B_{\mathbf{k}'} e^{-i\Theta}$ [see Eq. (18.329)] and the energy gap Δ is transformed according to [see Eq. (18.306)]

$$\Delta \rightarrow \Delta e^{-i\Theta}. \quad (18.365)$$

Moreover, the ground state $|\Psi_0\rangle$ is modified [see Eq. (18.357)] and becomes $|\Psi_0\rangle \rightarrow |\Psi(\Theta)\rangle$, where

$$|\Psi(\Theta)\rangle = \prod_{\mathbf{k}'} \mathcal{K}_{\mathbf{k}'}(\Theta) |0\rangle, \quad (18.366)$$

where the operator $\mathcal{K}_{\mathbf{k}'}(\Theta)$ is given by

$$\mathcal{K}_{\mathbf{k}'}(\Theta) = e^{i\phi_\Delta} \cos \theta_{\mathbf{k}'} - e^{i\Theta} e^{-i\phi_\Delta} \sin \theta_{\mathbf{k}'} B_{\mathbf{k}'}^\dagger. \quad (18.367)$$

As can be seen from Eq. (18.366), the vector state $|\Psi(\Theta)\rangle$ becomes identical to the ground state $|\Psi_0\rangle$ (18.357) when $\Theta = 2n\pi$, where n is integer. In view of the fact that the pair creation operator $B_{\mathbf{k}'}^\dagger = a_{\mathbf{k}',\uparrow}^\dagger a_{-\mathbf{k}',\downarrow}^\dagger$ (18.329) in Eq. (18.367) is multiplied by the factor $e^{i\Theta}$ one may argue that the phase Θ can be considered as the phase of Cooper pairs.

Claim. The state $|\Psi(\Theta)\rangle$ (18.366) can be alternatively expressed as

$$|\Psi(\Theta)\rangle = e^{in_P\Theta} |\Psi_0\rangle, \quad (18.368)$$

where $|\Psi_0\rangle$ is the BCS ground state (18.357) and where

$$n_P = \frac{1}{2} \sum_{\mathbf{k}',\sigma} a_{\mathbf{k}',\sigma}^\dagger a_{\mathbf{k}',\sigma} \quad (18.369)$$

is the so-called pair number operator.

Proof. On one hand

$$\begin{aligned} & \left(a_{\mathbf{k}',\uparrow}^\dagger a_{\mathbf{k}',\uparrow} + a_{-\mathbf{k}',\downarrow}^\dagger a_{-\mathbf{k}',\downarrow} \right) \mathcal{K}_{\mathbf{k}'}(\Theta) |0\rangle \\ &= -e^{i\Theta} e^{-i\phi_\Delta} \sin\theta_{\mathbf{k}'} \left(a_{\mathbf{k}',\uparrow}^\dagger a_{\mathbf{k}',\uparrow} + a_{-\mathbf{k}',\downarrow}^\dagger a_{-\mathbf{k}',\downarrow} \right) a_{\mathbf{k}',\uparrow}^\dagger a_{-\mathbf{k}',\downarrow}^\dagger |0\rangle \\ &= -e^{i\Theta} e^{-i\phi_\Delta} \sin\theta_{\mathbf{k}'} \left[a_{\mathbf{k}',\uparrow}^\dagger a_{-\mathbf{k}',\downarrow}^\dagger \left(1 - a_{\mathbf{k}',\uparrow}^\dagger a_{\mathbf{k}',\uparrow} \right) + a_{\mathbf{k}',\uparrow}^\dagger a_{-\mathbf{k}',\downarrow}^\dagger \left(1 - a_{-\mathbf{k}',\downarrow}^\dagger a_{-\mathbf{k}',\downarrow} \right) \right] |0\rangle \\ &= -e^{i\Theta} e^{-i\phi_\Delta} \sin\theta_{\mathbf{k}'} \left(a_{\mathbf{k}',\uparrow}^\dagger a_{-\mathbf{k}',\downarrow}^\dagger + a_{\mathbf{k}',\uparrow}^\dagger a_{-\mathbf{k}',\downarrow}^\dagger \right) |0\rangle, \end{aligned} \quad (18.370)$$

and thus

$$\begin{aligned} n_P \prod_{\mathbf{k}'} \mathcal{K}_{\mathbf{k}'}(\Theta) |0\rangle &= \frac{1}{2} \sum_{\mathbf{k}'} \left(a_{\mathbf{k}',\uparrow}^\dagger a_{\mathbf{k}',\uparrow} + a_{-\mathbf{k}',\downarrow}^\dagger a_{-\mathbf{k}',\downarrow} \right) \prod_{\mathbf{k}''} \mathcal{K}_{\mathbf{k}''}(\Theta) |0\rangle \\ &= - \sum_{\mathbf{k}'} \prod_{\mathbf{k}'' \neq \mathbf{k}'} \mathcal{K}_{\mathbf{k}''}(\Theta) e^{i\Theta} e^{-i\phi_\Delta} \sin\theta_{\mathbf{k}'} a_{\mathbf{k}',\uparrow}^\dagger a_{-\mathbf{k}',\downarrow}^\dagger |0\rangle. \end{aligned} \quad (18.371)$$

On the other hand

$$-i \frac{\partial}{\partial \Theta} \prod_{\mathbf{k}''} \mathcal{K}_{\mathbf{k}''}(\Theta) |0\rangle = -i \sum_{\mathbf{k}'} \prod_{\mathbf{k}'' \neq \mathbf{k}'} \mathcal{K}_{\mathbf{k}''}(\Theta) \frac{\partial \mathcal{K}_{\mathbf{k}'}}{\partial \Theta} |0\rangle, \quad (18.372)$$

and therefore [see Eq. (18.367)]

$$n_P |\Psi(\Theta)\rangle = -i \frac{\partial}{\partial \Theta} |\Psi(\Theta)\rangle, \quad (18.373)$$

where $|\Psi(\Theta)\rangle = \prod_{\mathbf{k}'} \mathcal{K}_{\mathbf{k}'}(\Theta) |0\rangle$ [see Eq. (18.366)]. The above result together with the Taylor expansion formula for the exponential function [see Eq. (3.31)] lead to $e^{in_P\Theta} |\Psi(0)\rangle = |\Psi(\Theta)\rangle$, which proves the claim (18.368).

18.7.1 The Second Josephson Relation

Consider the case where a voltage V is applied to a superconductor. The added energy of $\mu = eV$ per electron, where e is the electron charge, can be taken into account by adding a term to the Hamiltonian of the system, which becomes

$$\mathcal{H}(V) = \mathcal{H}_{\text{MF}} + 2\mu n_{\text{P}} , \quad (18.374)$$

where \mathcal{H}_{MF} is given by Eq. (18.318) and where the pair number operator n_{P} is given by Eq. (18.369). As will be shown below, the added term $2\mu n_{\text{P}}$ gives rise to time dependence of the complex energy gap Δ [see Eq. (18.306)].

Claim. The following holds

$$i\hbar \frac{d\Delta}{dt} = 2\mu\Delta . \quad (18.375)$$

Proof. With the help of the Heisenberg equation of motion (4.38) one finds that

$$i\hbar \frac{d\langle B_{\mathbf{k}'} \rangle}{dt} = \langle [B_{\mathbf{k}'}, \mathcal{H}(V)] \rangle . \quad (18.376)$$

thus [see Eqs. (18.327), (18.328), (18.329) and (18.318)]

$$\begin{aligned} i\hbar \frac{d\langle B_{\mathbf{k}'} \rangle}{dt} &= \eta_{\mathbf{k}'} e^{-2i\phi\Delta} \left\langle \left[\sin^2 \theta_{\mathbf{k}'} b_{-\mathbf{k}',\downarrow}^\dagger b_{\mathbf{k}',\uparrow}^\dagger - \cos^2 \theta_{\mathbf{k}'} b_{\mathbf{k}',\uparrow} b_{-\mathbf{k}',\downarrow}, N_{\mathbf{k}',\uparrow} + N_{-\mathbf{k}',\downarrow} \right] \right\rangle \\ &\quad + \mu \frac{e^{-2i\phi\Delta} \sin^2(2\theta_{\mathbf{k}'})}{2} \left\langle \left[N_{\mathbf{k}',\uparrow} + N_{-\mathbf{k}',\downarrow}, b_{\mathbf{k}',\uparrow} b_{-\mathbf{k}',\downarrow} + b_{-\mathbf{k}',\downarrow}^\dagger b_{\mathbf{k}',\uparrow}^\dagger \right] \right\rangle \\ &\quad + \mu e^{-2i\phi\Delta} \cos(2\theta_{\mathbf{k}'}) \left\langle \left[\sin^2 \theta_{\mathbf{k}'} b_{-\mathbf{k}',\downarrow}^\dagger b_{\mathbf{k}',\uparrow}^\dagger - \cos^2 \theta_{\mathbf{k}'} b_{\mathbf{k}',\uparrow} b_{-\mathbf{k}',\downarrow}, N_{\mathbf{k}',\uparrow} + N_{-\mathbf{k}',\downarrow} \right] \right\rangle \\ &\quad + \mu e^{-2i\phi\Delta} \sin(2\theta_{\mathbf{k}'}) \left\langle \left[b_{-\mathbf{k}',\downarrow}^\dagger b_{\mathbf{k}',\uparrow}^\dagger, b_{\mathbf{k}',\uparrow} b_{-\mathbf{k}',\downarrow} \right] \right\rangle . \end{aligned} \quad (18.377)$$

With the help of the commutation relations

$$\left[b_{-\mathbf{k}',\downarrow}^\dagger b_{\mathbf{k}',\uparrow}^\dagger, N_{\mathbf{k}',\uparrow} + N_{-\mathbf{k}',\downarrow} \right] = -2b_{-\mathbf{k}',\downarrow}^\dagger b_{\mathbf{k}',\uparrow}^\dagger , \quad (18.378)$$

$$\left[b_{-\mathbf{k}',\downarrow}^\dagger b_{\mathbf{k}',\uparrow}^\dagger, b_{\mathbf{k}',\uparrow} b_{-\mathbf{k}',\downarrow} \right] = N_{\mathbf{k}',\uparrow} + N_{-\mathbf{k}',\downarrow} - 1 , \quad (18.379)$$

one finds that

$$i\hbar \frac{d\langle B_{\mathbf{k}'} \rangle}{dt} = \mu e^{-2i\phi\Delta} \sin(2\theta_{\mathbf{k}'}) \langle N_{-\mathbf{k}',\downarrow} + N_{\mathbf{k}',\uparrow} - 1 \rangle , \quad (18.380)$$

and therefore [see Eqs. (18.330) and (18.336)]

$$i\hbar \frac{d\langle B_{\mathbf{k}'} \rangle}{dt} = 2\mu \langle B_{\mathbf{k}'} \rangle . \quad (18.381)$$

Thus, the complex energy gap Δ , which is given by [see Eq. (18.306)]

$$\Delta = \frac{g}{V} \sum_{\mathbf{k}'} \langle B_{\mathbf{k}'} \rangle , \quad (18.382)$$

satisfies Eq. (18.375).

For a fixed μ the solution of Eq. (18.375) reads

$$\Delta(t) = \Delta(0) e^{-i\Theta(t)} , \quad (18.383)$$

where the phase factor $\Theta(t)$ is given by

$$\Theta(t) = \frac{2\mu t}{\hbar} = \frac{2eVt}{\hbar} . \quad (18.384)$$

Taking the time derivative (which is denoted by overdot) yields, in agreement with Eq. (18.58), the second Josephson relation

$$\dot{\Theta} = \frac{2eV}{\hbar} . \quad (18.385)$$

18.7.2 The Energy of a Josephson Junction

Consider a system composed of two superconductors that are separated one from the other by a thin insulating layer, which serves as a tunneling barrier. The Hamiltonian of the system is assumed to be given by

$$\mathcal{H} = \mathcal{H}_1 + \mathcal{H}_2 + \mathcal{H}_T , \quad (18.386)$$

where \mathcal{H}_1 and \mathcal{H}_2 are the Hamiltonians of the two decoupled superconductors and where the tunneling Hamiltonian \mathcal{H}_T is taken to be given by

$$\begin{aligned} \mathcal{H}_T = & \sum_{\mathbf{k}', \mathbf{k}''} t_{\mathbf{k}', \mathbf{k}''} \left(a_{1, \mathbf{k}', \uparrow}^\dagger a_{2, \mathbf{k}'', \uparrow} + a_{1, -\mathbf{k}', \downarrow}^\dagger a_{2, -\mathbf{k}'', \downarrow} \right) \\ & + t_{\mathbf{k}', \mathbf{k}''}^* \left(a_{2, \mathbf{k}'', \uparrow}^\dagger a_{1, \mathbf{k}', \uparrow} + a_{2, -\mathbf{k}'', \downarrow}^\dagger a_{1, -\mathbf{k}', \downarrow} \right) , \end{aligned} \quad (18.387)$$

where the annihilation operators of the first (second) superconductor are labeled by $a_{1, \mathbf{k}', \sigma}$ ($a_{2, \mathbf{k}'', \sigma}$). With the help of Eq. (18.317) one finds that \mathcal{H}_T can be expressed as

$$\mathcal{H}_T = \sum_{\mathbf{k}', \mathbf{k}''} \mathcal{H}_{\mathbf{k}', \mathbf{k}''} , \quad (18.388)$$

where

$$\begin{aligned}
 \mathcal{H}_{\mathbf{k}',\mathbf{k}''} = & \mathcal{A}_{\mathbf{k}',\mathbf{k}''} \left(b_{1,-\mathbf{k}',\downarrow}^\dagger b_{2,\mathbf{k}'',\uparrow}^\dagger - b_{1,\mathbf{k}',\uparrow}^\dagger b_{2,-\mathbf{k}'',\downarrow}^\dagger \right) \\
 & + \mathcal{A}_{\mathbf{k}',\mathbf{k}''}^* \left(b_{2,\mathbf{k}'',\uparrow} b_{1,-\mathbf{k}',\downarrow} - b_{2,-\mathbf{k}'',\downarrow} b_{1,\mathbf{k}',\uparrow} \right) \\
 & + \mathcal{B}_{\mathbf{k}',\mathbf{k}''} \left(b_{1,-\mathbf{k}',\downarrow} b_{2,-\mathbf{k}'',\downarrow}^\dagger + b_{1,\mathbf{k}',\uparrow} b_{2,\mathbf{k}'',\uparrow}^\dagger \right) \\
 & + \mathcal{B}_{\mathbf{k}',\mathbf{k}''}^* \left(b_{2,-\mathbf{k}'',\downarrow} b_{1,-\mathbf{k}',\downarrow}^\dagger + b_{2,\mathbf{k}'',\uparrow} b_{1,\mathbf{k}',\uparrow}^\dagger \right),
 \end{aligned} \tag{18.389}$$

the coefficients $\mathcal{A}_{\mathbf{k}',\mathbf{k}''}$ and $\mathcal{B}_{\mathbf{k}',\mathbf{k}''}$ are given by

$$\mathcal{A}_{\mathbf{k}',\mathbf{k}''} = \tau_{\mathbf{k}',\mathbf{k}''} \cos \theta_{1,\mathbf{k}'} \sin \theta_{2,\mathbf{k}''} + \tau_{\mathbf{k}',\mathbf{k}''}^* \sin \theta_{1,\mathbf{k}'} \cos \theta_{2,\mathbf{k}''}, \tag{18.390}$$

$$\mathcal{B}_{\mathbf{k}',\mathbf{k}''} = \tau_{\mathbf{k}',\mathbf{k}''} \sin \theta_{1,\mathbf{k}'} \sin \theta_{2,\mathbf{k}''} - \tau_{\mathbf{k}',\mathbf{k}''}^* \cos \theta_{1,\mathbf{k}'} \cos \theta_{2,\mathbf{k}''}, \tag{18.391}$$

and where

$$\tau_{\mathbf{k}',\mathbf{k}''} = e^{i(\phi_{1\Delta} - \phi_{2\Delta})} t_{\mathbf{k}',\mathbf{k}''}. \tag{18.392}$$

We employ below time independent perturbation theory to calculate the correction δE to the system's energy to lowest nonvanishing order in the tunneling coefficients $|t_{\mathbf{k}',\mathbf{k}''}|$. The averaged total energy change δE is evaluated by summing over all basis states of the combined system and multiplying the energy change of each state by its thermal occupation probability. As can be seen from Eq. (9.32) δE vanishes to first order in $|t_{\mathbf{k}',\mathbf{k}''}|$. To second order in $|t_{\mathbf{k}',\mathbf{k}''}|$ the correction δE is found to be given by

$$\begin{aligned}
 \delta E = & 2 \sum_{\mathbf{k}',\mathbf{k}''} |\mathcal{A}_{\mathbf{k}',\mathbf{k}''}|^2 \left(\frac{n_{\mathbf{k}'} n_{\mathbf{k}''}}{\eta_{\mathbf{k}'} + \eta_{\mathbf{k}''}} - \frac{(1 - n_{\mathbf{k}'}) (1 - n_{\mathbf{k}''})}{\eta_{\mathbf{k}'} + \eta_{\mathbf{k}''}} \right) \\
 & + 2 \sum_{\mathbf{k}',\mathbf{k}''} |\mathcal{B}_{\mathbf{k}',\mathbf{k}''}|^2 \left(\frac{n_{\mathbf{k}'} (1 - n_{\mathbf{k}''})}{\eta_{\mathbf{k}'} - \eta_{\mathbf{k}''}} + \frac{(1 - n_{\mathbf{k}'}) n_{\mathbf{k}''}}{\eta_{\mathbf{k}''} - \eta_{\mathbf{k}'}} \right),
 \end{aligned} \tag{18.393}$$

where $\eta_{\mathbf{k}'}$ is given by Eq. (18.311) and $n_{\mathbf{k}'}$ is given by Eq. (18.335). With the help of Eqs. (18.330), (18.390), (18.391) and (18.392) one finds that

$$\begin{aligned}
 |\mathcal{A}_{\mathbf{k}',\mathbf{k}''}|^2 = & |\tau_{\mathbf{k}',\mathbf{k}''}|^2 \left(\cos^2 \theta_{1,\mathbf{k}'} \sin^2 \theta_{2,\mathbf{k}''} + \sin^2 \theta_{1,\mathbf{k}'} \cos^2 \theta_{2,\mathbf{k}''} \right) \\
 & + \frac{1}{2} \operatorname{Re} \left(\frac{t_{\mathbf{k}',\mathbf{k}''}^2 \Delta_1^* \Delta_2}{\eta_{1,\mathbf{k}'} \eta_{2,\mathbf{k}''}} \right),
 \end{aligned} \tag{18.394}$$

and

$$\begin{aligned}
 |\mathcal{B}_{\mathbf{k}',\mathbf{k}''}|^2 = & |\tau_{\mathbf{k}',\mathbf{k}''}|^2 \left(\sin^2 \theta_{1,\mathbf{k}'} \sin^2 \theta_{2,\mathbf{k}''} + \cos^2 \theta_{1,\mathbf{k}'} \cos^2 \theta_{2,\mathbf{k}''} \right) \\
 & - \frac{1}{2} \operatorname{Re} \left(\frac{t_{\mathbf{k}',\mathbf{k}''}^2 \Delta_1^* \Delta_2}{\eta_{1,\mathbf{k}'} \eta_{2,\mathbf{k}''}} \right).
 \end{aligned} \tag{18.395}$$

In what follows it will be assumed, for simplicity, that all tunneling amplitudes $t_{\mathbf{k}',\mathbf{k}''}$ are identical. Moreover, the two superconductors will be assumed to be of the same type, i.e. $|\Delta_1| = |\Delta_2| \equiv |\Delta|$. For this case all the terms $t_{\mathbf{k}',\mathbf{k}''}^2 \Delta_1^* \Delta_2$ can be expressed as

$$t_{\mathbf{k}',\mathbf{k}''}^2 \Delta_1^* \Delta_2 = \mathcal{T} |\Delta|^2 e^{i\Theta}, \quad (18.396)$$

where $\mathcal{T} = |t_{\mathbf{k}',\mathbf{k}''}|^2$ and where Θ is the relative phase difference between the two superconductors. The energy correction δE can be expressed as a function of Θ as

$$\delta E = (\delta E)_0 - E_J \cos \Theta, \quad (18.397)$$

where $(\delta E)_0$ is independent on Θ and where

$$\begin{aligned} E_J &= \sum_{\mathbf{k}',\mathbf{k}''} \frac{\mathcal{T} |\Delta|^2}{\eta_{1,\mathbf{k}'} \eta_{2,\mathbf{k}''}} \left(\frac{1 - n_{\mathbf{k}''} - n_{\mathbf{k}'}}{\eta_{\mathbf{k}'} + \eta_{\mathbf{k}''}} + \frac{n_{\mathbf{k}'} - n_{\mathbf{k}''}}{\eta_{\mathbf{k}'} - \eta_{\mathbf{k}''}} \right) \\ &= \sum_{\mathbf{k}',\mathbf{k}''} \frac{\mathcal{T} |\Delta|^2}{\eta_{1,\mathbf{k}'} \eta_{2,\mathbf{k}''}} \frac{(1 - 2n_{\mathbf{k}''}) \eta_{\mathbf{k}'} - (1 - 2n_{\mathbf{k}'}) \eta_{\mathbf{k}''}}{\eta_{\mathbf{k}'}^2 - \eta_{\mathbf{k}''}^2}. \end{aligned} \quad (18.398)$$

Replacing the sum by an integral leads to

$$E_J = \frac{\hbar |\Delta|^2}{\pi e^2 R_N} \int_0^\infty \int_0^\infty \frac{d\epsilon_1 d\epsilon_2}{\eta_1 \eta_2} \frac{\tanh \frac{\beta \eta_2}{2} \eta_1 - \tanh \frac{\beta \eta_1}{2} \eta_2}{\eta_1^2 - \eta_2^2}, \quad (18.399)$$

where R_N , which is given by

$$R_N = \frac{\hbar}{4\pi e^2 \mathcal{V}^2 D_0^2 \mathcal{T}}, \quad (18.400)$$

is the so-called normal state resistance, $\mathcal{V} D_0$ is the density of states, and where [see Eq. (18.311)]

$$\eta_n = \sqrt{\epsilon_n^2 + |\Delta|^2}. \quad (18.401)$$

The variable transformation

$$\eta_n = |\Delta| \cosh \theta_n, \quad (18.402)$$

$$\epsilon_n = |\Delta| \sinh \theta_n, \quad (18.403)$$

leads to

$$E_J = \frac{\hbar |\Delta|}{\pi e^2 R_N} I \left(\frac{\beta |\Delta|}{2} \right), \quad (18.404)$$

where the function $I(x)$ is given by

$$I(x) = \int_0^\infty \int_0^\infty d\theta_1 d\theta_2 \frac{\tanh(x \cosh \theta_2) \cosh \theta_1 - \tanh(x \cosh \theta_1) \cosh \theta_2}{\cosh^2 \theta_1 - \cosh^2 \theta_2}. \quad (18.405)$$

In the limit of zero temperature the integral can be evaluated using the variable transformation

$$\theta_p = \frac{\theta_1 + \theta_2}{2}, \quad (18.406)$$

$$\theta_m = \frac{\theta_1 - \theta_2}{2}, \quad (18.407)$$

which together with the identities

$$\cosh \theta_1 + \cosh \theta_2 = 2 \cosh \theta_p \cosh \theta_m, \quad (18.408)$$

$$\cosh \theta_1 - \cosh \theta_2 = 2 \sinh \theta_p \sinh \theta_m, \quad (18.409)$$

$$\int_{-\infty}^{\infty} \frac{d\theta}{\cosh \theta} = \pi, \quad (18.410)$$

lead to

$$\begin{aligned} E_J &= \frac{\hbar |\Delta|}{\pi e^2 R_N} \int_0^\infty \int_0^\infty \frac{d\theta_1 d\theta_2}{\cosh \theta_1 + \cosh \theta_2} \\ &= \frac{\hbar |\Delta|}{4\pi e^2 R_N} \int_{-\infty}^{\infty} \int_{-\infty}^{\infty} \frac{d\theta_1 d\theta_2}{\cosh \theta_1 + \cosh \theta_2} \\ &= \frac{\hbar |\Delta|}{4\pi e^2 R_N} \int_{-\infty}^{\infty} \frac{d\theta_p}{\cosh \theta_p} \int_{-\infty}^{\infty} \frac{d\theta_m}{\cosh \theta_m}, \end{aligned} \quad (18.411)$$

thus

$$E_J = \frac{\pi \hbar |\Delta|}{4e^2 R_N}. \quad (18.412)$$

For arbitrary temperature the result is

$$E_J = \frac{\pi \hbar |\Delta|}{4e^2 R_N} \tanh \frac{\beta |\Delta|}{2}. \quad (18.413)$$

18.7.3 The First Josephson Relation

As was shown above [see Eq. (18.397)], the energy of a Josephson junction U_J having phase Θ relative to the energy when the phase vanishes is given by [compare with Eq. (18.62)]

$$U_J = -E_J \cos \Theta. \quad (18.414)$$

Let $I(t)$ and $V(t)$ be the current through and voltage across a Josephson junction, respectively, at time t . Assume that initially at time $t = 0$ the phase Θ vanishes. Energy conservation leads to the requirement that

$$U_J = \int_0^t dt' I(t') V(t') . \quad (18.415)$$

With the help of the second Josephson relation $\dot{\Theta} = (2e/\hbar) V$ (18.385) and Eq. (18.414) this becomes

$$-E_J \cos \Theta = \frac{\hbar}{2e} \int_0^\Theta d\Theta' I . \quad (18.416)$$

Taking the derivative with respect to Θ leads, in agreement with Eq. (18.56), to the first Josephson relation

$$I = I_c \sin \Theta , \quad (18.417)$$

where the so-called critical current I_c is given by

$$I_c = \frac{2eE_J}{\hbar} = \frac{2\pi cE_J}{\phi_s} , \quad (18.418)$$

where

$$\phi_s = \frac{hc}{2e} \quad (18.419)$$

is the superconducting flux quantum, which is identical to the superconducting flux quantum given by Eq. (18.44) provided that the charge q_s^* is taken to be $2e$. Note also that for the 'normal' flux quantum ϕ_0 given by Eq. (12.48) the charge of elementary carrier is e .

18.8 Problems

1. **Rotating Superconductor** - Consider a superconductor rotating at angular frequency Ω around the z axis. In the presence of an externally applied magnetic field \mathbf{B} calculate the magnetic field deep inside the superconductor.
2. Consider a conductor containing charge carriers having charge q and mass m . The density of charge carriers at point \mathbf{r} is $n(\mathbf{r})$ and the current density is $\mathbf{J}(\mathbf{r})$. Contrary to the case of a normal metal, it is assumed that *all* charge carriers at point \mathbf{r} move at the same velocity \mathbf{v} , which is related to \mathbf{J} by the relation [see Eq. (18.254)]

$$\mathbf{v} = \frac{\mathbf{J}}{qn} . \quad (18.420)$$

Show that in steady state this assumption leads to the 2nd London equation [see Eq. (18.25)]

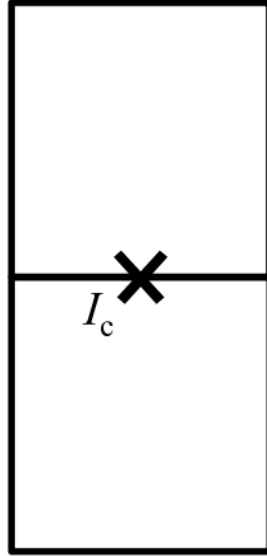

Fig. 18.6. Gradiometer RF SQUID.

$$\nabla^2 \mathbf{H} = \frac{1}{\lambda_L^2} \mathbf{H}, \quad (18.421)$$

where \mathbf{H} is the magnetic field and where

$$\lambda_L = \sqrt{\frac{mc^2}{4\pi nq^2}}. \quad (18.422)$$

3. Consider a sphere of radius R made of a type I superconductor. A uniform and time independent magnetic field $\mathbf{H} = H\hat{\mathbf{z}}$ (smaller than the critical field) is externally applied. Calculate the magnetic induction \mathbf{B} everywhere outside the sphere, in the limit where the London penetration depth vanishes.
4. Consider the so-called gradiometer RF SQUID seen in Fig. 18.6. The junction's critical current is labeled by I_c . It is assumed that the junction has capacitance, which is denoted by C_J . Consider the case where a magnetic flux that is denoted by ϕ_{e1} (ϕ_{e2}) is externally applied to the upper (lower) loop. Let A_1 (A_2) be the self inductance of the upper (lower) loop. Derive an equation of motion for the system.
5. **Cooper pair box** - Find an Hamiltonian for the device seen in Fig. 18.7.
6. The Hamiltonian of a Cooper pair box is given by Eq. (18.555). The potential energy term $-E_J \cos \Phi$ in Eq. (18.555) can be expanded as

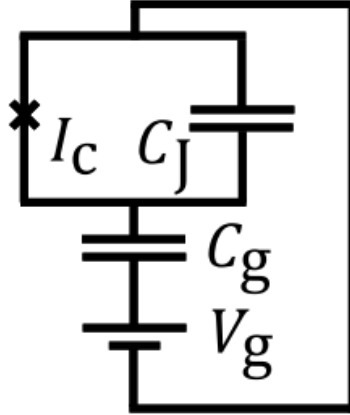

Fig. 18.7. Cooper pair box.

$$-E_J \cos \Phi = E_J \left(-1 + \frac{\Phi^2}{2} - \frac{\Phi^4}{24} \right) + O(\Phi^6) . \quad (18.423)$$

Consider the case where terms of order $O(\Phi^6)$ can be disregarded, and the term of order Φ^4 in Eq. (18.423) can be treated as a perturbation. Calculate to lowest nonvanishing order in time-independent perturbation theory the transition angular frequency $(E_1 - E_0)/\hbar$ between the ground state (having energy E_0) and the first excited state (having energy E_1), and the transition angular frequency $(E_2 - E_1)/\hbar$ between the first excited state and second excited state (having energy E_2).

7. Consider the DC SQUID shown in Fig. 18.4. The Josephson junctions on both arms of the DC SQUID have critical currents I_{c1} and I_{c2} , respectively, and both have the same capacitance C_J . The self inductance of the loop is denoted as Λ . A bias current I_b is externally injected and a magnetic flux ϕ_e is externally applied to the loop. Let $I_{b,c}$ be the critical current of the device, i.e. the largest bias current that can be applied with no resistance. Calculate $I_{b,c}$ in the limit $\beta_L \equiv 2\pi\Lambda I_c/\phi_s \ll 1$.
8. The dimensionless potential energy u of a DC SQUID (see Fig. 18.4) is given by Eq. (18.577), which can be rewritten as

$$u = -\cos \gamma_+ \cos \gamma_- + \alpha \sin \gamma_+ \sin \gamma_- - \frac{I_b \gamma_+}{I_c} + \frac{2 \left(\gamma_- + \frac{\pi \phi_e}{\phi_s} \right)^2}{\beta_L} , \quad (18.424)$$

The Josephson junctions on both arms of the DC SQUID have critical currents I_{c1} and I_{c2} , and flux variables ϕ_1 and ϕ_2 , respectively. The coor-

ordinates γ_{\pm} are given by $\gamma_{\pm} = \pi(\phi_1 \pm \phi_2)/\phi_s$, I_c is given by $I_c = I_{c1} + I_{c2}$, and the asymmetry parameter α is given by $\alpha = (I_{c1} - I_{c2})/I_c$. The self inductance of the loop is denoted by Λ . Externally controlled parameters are the bias current I_b , and magnetic flux ϕ_e applied to the loop. Assume that $\beta_L \equiv 2\pi\Lambda I_c/\phi_s \gg 1$.

- a) Calculate the Hessian matrix H , which is given by

$$H = \begin{pmatrix} \frac{\partial^2 u}{\partial \gamma_+^2} & \frac{\partial^2 u}{\partial \gamma_+ \partial \gamma_-} \\ \frac{\partial^2 u}{\partial \gamma_+ \partial \gamma_-} & \frac{\partial^2 u}{\partial \gamma_-^2} \end{pmatrix}, \quad (18.425)$$

in the limit $\beta_L \rightarrow \infty$. Use the result to calculate $\det H$ and $\text{Tr } H$.

- b) Consider the square that is defined by the four vertices having (γ_+, γ_-) coordinates given by $(\pi/2, 0)$, $(0, \pi/2)$, $(-\pi/2, 0)$ and $(0, -\pi/2)$. Show that $\det H = 0$ along the edges of this square, and that $\text{Tr } H > 0$ inside the square.
- c) Use the relations $0 = \partial u/\partial \gamma_+$ and $0 = \partial u/\partial \gamma_-$, to relate the square in the (γ_+, γ_-) plane, to a curve in the plane of normalized control parameters $(p_b, p_e) = (I_b/I_c, 4\pi\phi_e/(\beta_L\phi_s))$.
- d) Explain the physical significance of the curve in the normalized control parameters plane (p_b, p_e) .
9. Consider the mechanical flux qubit seen in Fig. 18.8. The Josephson junction has critical current I_c and capacitance C_J . The superconducting loop, which has self inductance Λ , contains a freely suspended section that is allowed to mechanically oscillate in the plane of the loop. The coordinate of the mechanical fundamental flexural mode, which has angular frequency ω_m and effective mass m , is denoted by x . Other mechanical modes of the suspended beam are disregarded. The mechanical motion gives rise to a change in the loop area given by $l_m x$, where l_m is the effective length of the suspended section. A magnetic field is applied perpendicularly to the plane of the loop. Let ϕ_e be the externally applied flux for the case $x = 0$, and B the component of the magnetic field normal to the plane of the loop at the location of the doubly clamped beam (it is assumed that B is constant in the region where the beam oscillates). The total magnetic flux threading the loop is denoted by ϕ .
- a) Express the Lagrangian \mathcal{L} as a function of the coordinates ϕ and x , and their time derivatives $\dot{\phi}$ and \dot{x} . Show that the Euler-Lagrange equation for ϕ expresses the law of current conservation, and the Euler-Lagrange equation for x expresses Newton's second law.
- b) Express the Hamiltonian \mathcal{H} as a function of the coordinates ϕ and x and their canonical conjugate variables.
10. Consider the Josephson junction shown in Fig. 18.9. The junction has an effective thickness d_J , which is roughly given by $d_J \simeq d_0 + 2\lambda_L$, where d_0 is the thickness of the insulating layer, and λ_L is the London penetration depth, and a rectangular cross section having area $L_x L_y$ (it is assumed

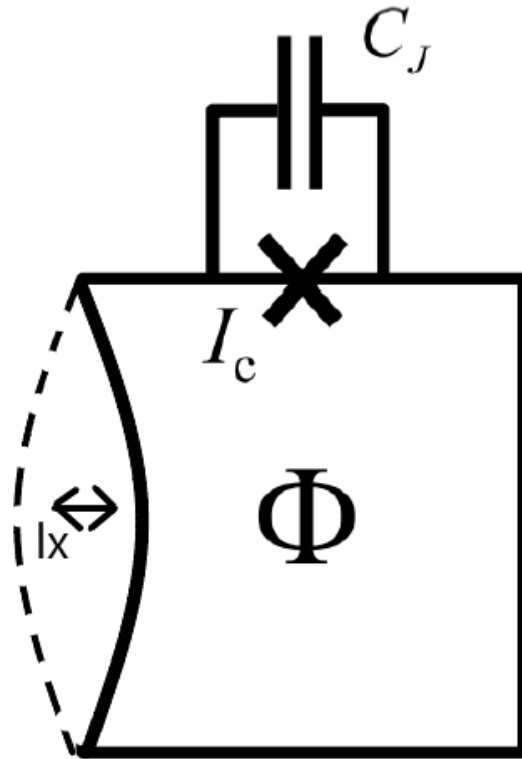

Fig. 18.8. Mechanical flux qubit.

that $L_x, L_y \gg \lambda_L$). A magnetic field $\mathbf{B} = B\hat{y}$ is externally applied. Show that the junction critical current I_c is given by

$$I_c = J_c L_x L_y \frac{\sin \frac{\kappa L_x}{2}}{\frac{\kappa L_x}{2}}, \quad (18.426)$$

where $\kappa = 2\pi B d_J / \phi_s$, and where J_c is the critical current density.

11. Consider the flux qubit device shown in Fig. 18.10. The flux qubit loop, which has self inductance Λ , is interrupted by a Josephson junction having a critical current I_c and capacitance C_J . The dimensionless screening parameter of the qubit is $\beta_L = 2\pi\Lambda I_c / \phi_s$ [see Eq. (18.87)], where ϕ_s is the flux quantum. A normally applied magnetic field produces a flux ϕ_e threading the flux qubit loop. Consider the case where $\phi_e = \phi_s/2$ and where $\beta_L > 1$. For this case the ground $|+\rangle$ and first excited $|-\rangle$ states of the flux qubit are given by $|\pm\rangle = 2^{-1/2}(|\curvearrowright\rangle \pm |\curvearrowleft\rangle)$ [see Eq. (18.152)], where $|\curvearrowright\rangle$ ($|\curvearrowleft\rangle$) represents a state of the flux qubit for which

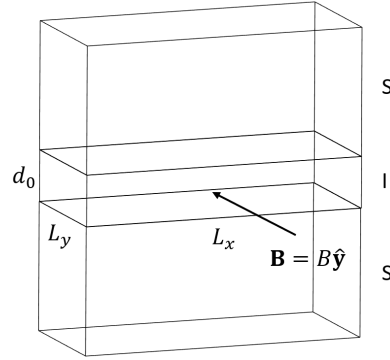

Fig. 18.9. Magnetic field $\mathbf{B} = B\hat{y}$ applied to a Josephson junction.

the persistent current circulating in the loop flows in the clockwise (counterclockwise) direction. The flux qubit, which is treated as a two-level system, is inductively coupled to both, a DC-SQUID on the left (mutual inductance is M_x), and to an LC resonator on the right (mutual inductance is M_z). Both the DC-SQUID and the LC resonator serve as switchable detectors [it is assumed that the DC SQUID (LC resonator) has no effect on the flux qubit, when it is switched off, i.e. when $I_{DC} = 0$ ($I_{LC} = 0$)]. The angular frequency ω_p used to operate the LC resonator is assumed to be given by $\omega_p = \omega_e = \sqrt{c/(LC)}$ [see Eq. (18.102)]. Recall that the effective resonance frequency of the LC resonator depends on the energy eigenstate occupied by the flux qubit [see Eqs. (18.188) and (18.189)]. Hence, the measurement performed by the LC resonator can be represented by the observable $\Sigma_z = |+\rangle\langle+| - |-\rangle\langle-|$ (18.158). A DC SQUID allows measuring the total magnetic flux applied to its loop, which is affected by the flux qubit circulating current due to the mutual inductance M_x . Hence, the measurement performed by the DC SQUID can be represented by the observable $\Sigma_x = |\curvearrowright\rangle\langle\curvearrowright| - |\curvearrowleft\rangle\langle\curvearrowleft|$. The flux qubit is initially prepared in the state $|\curvearrowright\rangle$. A short pulse I_{LC} is applied to perform a measurement with the LC resonator. Immediately afterwards, a short pulse I_{DC} is applied to perform a measurement with the DC SQUID resonator. Calculate the initial $\langle\Sigma_x\rangle_i$ and final $\langle\Sigma_x\rangle_f$ values of $\langle\Sigma_x\rangle$ (angled brackets $\langle\rangle$ represent expectation value). Is angular momentum conserved?

12. **decoherence and recoherence** - Consider an LC resonator coupled to a flux qubit biased with an applied magnetic flux ϕ_e given by $\phi_e = \phi_s/2$ (see Fig. 18.10). When the resonator frequency ω_e [see Eq. (18.102)] is much smaller than the qubit frequency ω_a [see Eq. (18.155)], the adiabatic approximation can be employed. Consider an initial system state having the form $|\psi\rangle(t=0) = |+\rangle \otimes |\phi_+\rangle + |-\rangle \otimes |\phi_-\rangle$, where $|+\rangle$ is the qubit

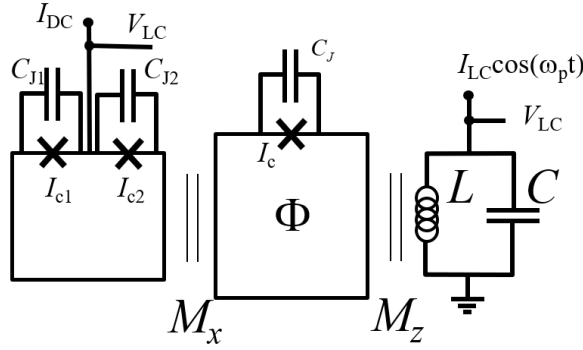

Fig. 18.10. Flux qubit coupled to DC SQUID and LC resonator.

ground state, $|-\rangle$ is the qubit first excited state, and where $|\phi_+\rangle$ and $|\phi_-\rangle$ are arbitrary resonator states. In the adiabatic approximation, the state $|\psi\rangle$ evolves in time as [see Eq. (13.84)]

$$|\psi\rangle(t) = e^{-\frac{i\varepsilon_+ t}{\hbar}} |+\rangle \otimes u_+ |\phi_+\rangle + e^{-\frac{i\varepsilon_- t}{\hbar}} |-\rangle \otimes u_- |\phi_-\rangle, \quad (18.427)$$

where ε_{\pm} is a qubit eigenenergy [see Eq. (18.154)], the unitary operator u_{\pm} is given by $u_{\pm} = \exp(-i\hbar^{-1}\mathcal{H}_{\pm}t)$ [see Eq. (4.13)], where the Hamiltonian \mathcal{H}_{\pm} is given by $\mathcal{H}_{\pm} = \hbar\omega_{e,\pm}(A^{\dagger}A + 1/2)$, $A^{\dagger}A$ is a resonator number operator, and $\omega_{e,\pm}$ is an effective resonator angular frequency, corresponding to a qubit occupying the state $|\pm\rangle$. Consider the case where the qubit-resonator system is prepared at time $t = 0$ in the state $|\curvearrowright\rangle \otimes |\alpha\rangle$, where $|\curvearrowright\rangle$ and $|\curvearrowleft\rangle$ are qubit circulating current states, α is complex, and $|\alpha\rangle$ is a resonator coherent state. Note that a device similar to the one shown in Fig. 18.10 can be used for performing such a preparation. Employ the adiabatic approximation to calculate the expectation value $\langle \Sigma_x \rangle(t)$ at time $t > 0$, to lowest nonvanishing order in the qubit-resonator coupling coefficient g .

13. Resistively and capacitively shunted Josephson junction (RCSJ)

- Consider a RCSJ composed of a Josephson junction having a critical current I_c connected in parallel with both a shunt capacitor having capacitance C_J and a shunt resistor having resistance R_J . A bias current given by $i_b I_c$ is injected into the RCSJ, where i_b is a dimensionless constant.

- a) Calculate the time-averaged voltage V_{dc} across the device for the so-called overdamped case, for which $\beta_C \ll 1$, where the so-called Stewart-McCumber parameter β_C is given by [ϕ_s is defined by Eq. (18.44)]

$$\beta_C = \frac{2\pi c I_c R_J^2 C_J}{\phi_s}. \quad (18.428)$$

b) For the same case calculate the Fourier spectrum of the voltage across the device.

14. **Shapiro steps** - A voltage given by

$$V(t) = V_0 + V_1 \cos(\omega t) , \quad (18.429)$$

where V_0 , V_1 and ω are all constants, is applied across a RCSJ. Calculate the current for the overdamped case $\beta_C \ll 1$ [see Eq. (18.428)].

15. A qubit state vector $|\alpha\rangle(t)$ is expressed as $|\alpha\rangle(t) = a_+(t)|+\rangle + a_-(t)|-\rangle$, where $\{|+\rangle, |-\rangle\}$ is an orthonormal basis for the qubit Hilbert space. The time evolution of $\bar{a} = (a_+, a_-)^T$ is governed by the Schrödinger equation

$$i\hbar \frac{d\bar{a}}{dt} = \mathcal{H}\bar{a} . \quad (18.430)$$

Consider the case where the Hamiltonian matrix \mathcal{H} is given by

$$\mathcal{H} = \frac{\hbar}{2} \begin{pmatrix} \omega_f & \omega_\Delta e^{-i\omega t} \\ \omega_\Delta e^{i\omega t} & -\omega_f \end{pmatrix} , \quad (18.431)$$

where

$$\omega_f = \omega_{f0} - \omega_{f1} \cos(\omega_p t) , \quad (18.432)$$

and where ω_{f0} , ω_{f1} , ω_p , ω_Δ and ω are all positive constants. A general unitary transformation given by $\bar{a} = U\bar{b}$, where $\bar{b} = (b_+, b_-)^T$, maps the Schrödinger equation into

$$i\hbar \frac{d\bar{b}}{dt} = \mathcal{H}'\bar{b} , \quad (18.433)$$

where \mathcal{H}' is the transformed Hamiltonian. Find a unitary transformation U (which may be time dependent), for which the diagonal elements of the transformed Hamiltonian matrix \mathcal{H}' become time independent. Employ the result to derive an effective Hamiltonian \mathcal{H}'_n for the region where $\omega + n\omega_p \simeq \omega_{f0}$, where n is an integer.

16. Consider a superconducting loop interrupted by three Josephson junctions. The n 'th junction has capacitance C_n and Josephson energy E_{Jn} , where $n \in \{1, 2, 3\}$. The loop has negligibly small self inductance. The externally applied magnetic flux is denoted by ϕ_e . The third junction is smaller in area by a factor α , compared to the first and the second junctions, which are assumed to be identical, i.e. $C_1 = C_2 \equiv C_J$, $E_{J1} = E_{J2} \equiv E_J$, $C_3 = \alpha C_J$ and $E_{J3} = \alpha E_J$. Derive a Lagrangian \mathcal{L} for the system. If needed, employ a transformation to a set of coordinates $\{\varphi_n\}$, for which the kinetic energy T becomes proportional to $\sum_n \dot{\varphi}_n^2$ (i.e. all coordinates φ_n share the same 'mass'). Derive the potential energy as a function of these coordinates φ_n .

17. A point particle having positive charge e is localized at the point $\mathbf{r} = 0$ inside a metal having Fermi velocity v_F . Calculate the screened potential $\varphi(\mathbf{r})$ at location \mathbf{r} in the Thomas-Fermi approximation at zero temperature.
18. **electron-phonon interaction** - Elementary acoustic excitations in solids are commonly referred to as phonons. The Hamiltonian of a conducting medium is assumed to be given by

$$\mathcal{H} = \sum_{\mathbf{k}} \varepsilon_{\mathbf{a},\mathbf{k}} a_{\mathbf{k}}^\dagger a_{\mathbf{k}} + \sum_{\mathbf{q}} \varepsilon_{\mathbf{c},\mathbf{q}} c_{\mathbf{q}}^\dagger c_{\mathbf{q}} + i\hbar g \sum_{\mathbf{k},\mathbf{q}} a_{\mathbf{k}+\mathbf{q}}^\dagger a_{\mathbf{k}} (c_{\mathbf{q}} - c_{-\mathbf{q}}^\dagger), \quad (18.434)$$

where the Fermion (Boson) operator $a_{\mathbf{k}}^\dagger$ ($c_{\mathbf{q}}^\dagger$) creates an electron (a phonon) having wave vector \mathbf{k} (\mathbf{q}) and energy $\varepsilon_{\mathbf{a},\mathbf{k}}$ ($\varepsilon_{\mathbf{c},\mathbf{q}}$). The coefficient g represents the electron-phonon coupling. Note that the coupling term preserves the total momentum. Employ the Schrieffer-Wolff transformation given by Eq. (9.107), and consider the case where the temperature is sufficiently low in order to allow simplifying Eq. (9.107) by assuming that both states $|k'\rangle$ and $|k''\rangle$ in Eq. (9.107) have zero phonons. Derive an effective Hamiltonian \mathcal{H}_{ee} for the phonon-mediated electron-electron interaction for this case.

19. Calculate $\langle n_P \rangle$ and $\langle (\Delta n_P)^2 \rangle$ with respect to the BCS ground state $|\Psi_0\rangle$, where n_P is the pairs number operator (18.369).
20. Calculate the energy density of states for elementary excitations in a superconductor.
21. Find the time evolution of the operators $a_{\mathbf{k},\uparrow}(t)$ and $a_{-\mathbf{k},\downarrow}^\dagger(t)$ at time t [see the Hamiltonian (18.301)] for given initial conditions $a_{\mathbf{k},\uparrow}(0)$ and $a_{-\mathbf{k},\downarrow}^\dagger(0)$ at time $t = 0$.
22. Employ the BCS model to calculate the entropy σ_S of a superconductor in the low temperature limit $T \ll \Delta_0/k_B$, where Δ_0 is the energy gap at zero temperature, and k_B is Boltzmann's constant. Compare your result to the entropy of a free electron gas given by Eq. (16.291).
23. The specific heat C is defined by

$$C = T \frac{d\sigma}{dT}, \quad (18.435)$$

where T is the temperature, and σ is the entropy. Calculate C_S for a superconductor in the low temperature limit. Compare your result with the free electron gas specific heat C_N in the same low temperature limit.

24. The critical field, i.e. the largest magnetic field that can be applied to a superconductor before it undergoes a phase transition to the normal conducting phase, is denoted by B_c . Estimate B_c by assuming that [see Eq. (14.42)]

$$\frac{\mathcal{V}B_c^2}{8\pi} = E_N - E_S, \quad (18.436)$$

where \mathcal{V} is the volume of the superconductor, and E_N (E_S) is the ground state energy in the normal (superconducting) phase. Assume that $|\Delta| \ll \epsilon_F$, where $|\Delta|$ is the superconducting energy gap, and ϵ_F is the Fermi energy. The term $E_N - E_S$ can be calculated using the mean field Hamiltonian \mathcal{H}_{MF} . Note, however, that \mathcal{H}_{MF} that is given by Eq. (18.318) was derived by disregarding constant terms. Show that when all the constant terms are kept, the mean field Hamiltonian becomes

$$\mathcal{H}_{\text{MF,T}} = \sum_{\mathbf{k}',\sigma} \eta_{\mathbf{k}'} N_{\mathbf{k}',\sigma} + \mathcal{H}_{\text{MF,C}} , \quad (18.437)$$

where the term $\mathcal{H}_{\text{MF,C}}$ is given by [see Eqs. (18.304) and (18.306)]

$$\mathcal{H}_{\text{MF,C}} = \sum_{\mathbf{k}'} \epsilon_{\mathbf{k}'} - \epsilon_F - \eta_{\mathbf{k}'} + \Delta \langle B_{\mathbf{k}'}^\dagger \rangle . \quad (18.438)$$

Use the expression given by Eq. (18.437) to calculate $E_N - E_S$.

25. **Jordan-Wigner transformation** - Consider a one-dimensional equally-spaced array containing L sites. Each site is occupied by a spin 1/2 particle. The vector operator $\boldsymbol{\sigma}_l = (\sigma_{l,x}, \sigma_{l,y}, \sigma_{l,z})$ [see Eq. (6.137)] represents the angular momentum in units of $\hbar/2$ of the spin localized in the l 'th site, where $l \in \{1, 2, \dots, L\}$. The operator a_l is defined by

$$a_l = Q_l^{-1} \sigma_{l,+} , \quad (18.439)$$

where

$$\sigma_{l,\pm} = \frac{\sigma_{l,x} \pm i\sigma_{l,y}}{2} , \quad (18.440)$$

$$Q_l = e^{i\pi \sum_{l'=1}^{l-1} N_{l'}} , \quad (18.441)$$

and where

$$N_l = \sigma_{l,-} \sigma_{l,+} . \quad (18.442)$$

- a) Show that [see Eq. (18.441)]

$$Q_l = Q_l^\dagger = Q_l^{-1} , \quad (18.443)$$

and

$$Q_l^2 = 1 . \quad (18.444)$$

- b) Show that the operators a_l satisfy Fermionic relations [compare with Eqs. (16.8) and (16.9)]

$$[a_{l'}, a_{l''}]_+ = [a_{l'}^\dagger, a_{l''}^\dagger]_+ = 0 , \quad (18.445)$$

$$[a_{l'}, a_{l''}^\dagger]_+ = \delta_{l',l''} , \quad (18.446)$$

where $[,]_+$ denotes anti-commutation (i.e. $[A, B]_+ = AB + BA$).

c) Show that

$$\sigma_{l,z} = 1 - 2N_l = (a_l^\dagger + a_l) (a_l^\dagger - a_l) , \quad (18.447)$$

and

$$\sigma_{l,x}\sigma_{l+1,x} = (a_l^\dagger - a_l) (a_{l+1}^\dagger + a_{l+1}) , \quad (18.448)$$

$$\sigma_{l,y}\sigma_{l+1,y} = - (a_l^\dagger + a_l) (a_{l+1}^\dagger - a_{l+1}) . \quad (18.449)$$

d) **One-dimensional Ising model** - Consider the Hamiltonian

$$\mathcal{H} = -\Omega \sum_{l=1}^L \sigma_{l,z} - J \sum_{l=1}^L \sigma_{l,x}\sigma_{l+1,x} , \quad (18.450)$$

where both Ω and J are real constants. It is assumed that the spin array is arranged along a ring, and thus, the last ($l = L$) coupling term $\sigma_{l,x}\sigma_{l+1,x}$ [see Eq. (18.450)] is taken to be given by $\sigma_{L,x}\sigma_{1,x}$. Show that in terms of the Fermionic operators a_l the Hamiltonian \mathcal{H} (18.450) can be expressed as

$$\begin{aligned} \mathcal{H} = & -\Omega \sum_{l=1}^L (1 - 2N_l) - J \sum_{l=1}^{L-1} (a_l^\dagger - a_l) (a_{l+1}^\dagger + a_{l+1}) \\ & + J e^{i\pi N} (a_L^\dagger - a_L) (a_1^\dagger + a_1) , \end{aligned} \quad (18.451)$$

where

$$N = \sum_{l=1}^L N_l . \quad (18.452)$$

e) Show that

$$[e^{i\pi N}, \mathcal{H}] = 0 . \quad (18.453)$$

f) The operator A_n is defined by [compare with Eq. (2.253)]

$$A_n = \frac{e^{-i\varphi}}{\sqrt{L}} \sum_{l=1}^L e^{-\frac{2\pi i n l}{L}} a_l , \quad (18.454)$$

where φ is real. The index n can take L different values given by

$$n \in \mathcal{N}(n_0) \equiv n_0 + \{1, 2, \dots, L\} , \quad (18.455)$$

where n_0 is a real constant. Show that the set of operators A_n satisfy Fermionic commutation relations given by

$$[A_{n'}, A_{n''}]_+ = [A_{n'}^\dagger, A_{n''}^\dagger]_+ = 0, \quad (18.456)$$

$$[A_{n'}, A_{n''}^\dagger]_+ = \delta_{n', n''}. \quad (18.457)$$

g) As was shown above, $\langle e^{i\pi N} \rangle$ is time independent [see Eqs. (4.38) and (18.453)]. For cases where $\langle e^{i\pi N} \rangle = \pm 1$, it is convenient to replace the Hamiltonian \mathcal{H} (18.451) by

$$\mathcal{H} = -\Omega \sum_{l=1}^L (1 - 2N_l) - J \sum_{l=1}^L (a_l^\dagger - a_l) (a_{l+1}^\dagger + a_{l+1}), \quad (18.458)$$

where

$$a_{L+1} \equiv \begin{cases} -a_1 & \text{for } \langle e^{i\pi N} \rangle = +1 \\ +a_1 & \text{for } \langle e^{i\pi N} \rangle = -1 \end{cases}. \quad (18.459)$$

Show that in terms of the operators A_n , the Hamiltonian \mathcal{H} (18.458) can be expressed as

$$\mathcal{H} = \sum_{n \in \mathcal{N}(n_0)} \Upsilon_n^\dagger M_n \Upsilon_n, \quad (18.460)$$

where [compare to Eq. (18.307)]

$$\Upsilon_n = \begin{pmatrix} A_n \\ A_{-n}^\dagger \end{pmatrix}, \quad (18.461)$$

$$\Upsilon_n^\dagger = (A_n^\dagger \ A_{-n}), \quad (18.462)$$

$$M_n = \begin{pmatrix} \Omega - J \cos k_n & -iJ e^{-2i\varphi} \sin k_n \\ iJ e^{2i\varphi} \sin k_n & -\Omega + J \cos k_n \end{pmatrix}, \quad (18.463)$$

and where

$$k_n = \frac{2\pi n}{L}. \quad (18.464)$$

h) **Bogoliubov transformation** - Show that [see Eq. (18.460)]

$$\Upsilon_n^\dagger M_n \Upsilon_n = \eta_n (b_n^\dagger b_n - b_{-n} b_{-n}^\dagger), \quad (18.465)$$

where [compare with Eq. (18.311)]

$$\begin{aligned}\eta_n &= \sqrt{(\Omega - J \cos k_n)^2 + (J \sin k_n)^2} \\ &= \sqrt{(\Omega - J)^2 + 4\Omega J \sin^2 \frac{k_n}{2}},\end{aligned}\tag{18.466}$$

$$\begin{pmatrix} b_n \\ b_{-n}^\dagger \end{pmatrix} = U_n^{-1} \begin{pmatrix} A_n \\ A_{-n}^\dagger \end{pmatrix},\tag{18.467}$$

$$U_n = \begin{pmatrix} e^{-i(\varphi+\pi/4)} \cos \theta_n & -e^{-i(\varphi+\pi/4)} \sin \theta_n \\ e^{i(\varphi+\pi/4)} \sin \theta_n & e^{i(\varphi+\pi/4)} \cos \theta_n \end{pmatrix},\tag{18.468}$$

and where

$$\theta_n = \frac{1}{2} \tan^{-1} \left(\frac{J \sin k_n}{\Omega - J \cos k_n} \right).\tag{18.469}$$

Note that in terms of the operators b_n , the Hamiltonian \mathcal{H} (18.460) can be expressed as

$$\mathcal{H} = 2 \sum_{n \in \mathcal{N}(n_0)} \eta_n b_n^\dagger b_n - E_0,\tag{18.470}$$

where

$$E_0 = \sum_{n \in \mathcal{N}(n_0)} \eta_n.\tag{18.471}$$

i) **Entropy** - Show that the entropy Σ at temperature T is given by

$$\frac{\Sigma}{L} = \frac{1}{\pi} \int_0^\pi dk [\log(2 \cosh(\epsilon(k))) - \epsilon(k) \tanh(\epsilon(k))],\tag{18.472}$$

where

$$\epsilon(k) = \beta\Omega \sqrt{\left(1 - \frac{J}{\Omega}\right)^2 + 4\frac{J}{\Omega} \sin^2 \frac{k}{2}},\tag{18.473}$$

and where $\beta = 1/(k_B T)$. Note that for the decoupled case (i.e. for $J = 0$), Eq. (18.472) yields [see Eq. (18.739), and compare with Eq. (8.582)]

$$\begin{aligned}\frac{\Sigma}{L} &= \log(2 \cosh(\beta\Omega)) - \beta\Omega \tanh(\beta\Omega) \\ &= -\frac{1-x}{2} \log \frac{1-x}{2} - \frac{1+x}{2} \log \frac{1+x}{2},\end{aligned}\tag{18.474}$$

where

$$x = \tanh(\beta\Omega).\tag{18.475}$$

- j) **Mean field approximation** - Consider a product state, for which all L spins are in the same single spin state $|\psi(\theta, \phi)\rangle$, which is given by

$$|\psi(\theta, \phi)\rangle \doteq \begin{pmatrix} \cos \frac{\theta}{2} \\ e^{i\phi} \sin \frac{\theta}{2} \end{pmatrix}, \quad (18.476)$$

where both θ and ϕ are real. The energy expectation value is denoted by $\langle \mathcal{H} \rangle$, and the values of the angles θ and ϕ , for which $\langle \mathcal{H} \rangle$ is minimized, are denoted by θ_m and ϕ_m , respectively. Show that

$$\langle \sigma_x \rangle_m = \begin{cases} 0 & \text{for } \frac{2J}{\Omega} < 1 \\ \pm \sqrt{1 - \left(\frac{\Omega}{2J}\right)^2} & \text{for } \frac{2J}{\Omega} \geq 1 \end{cases}, \quad (18.477)$$

where $\langle \sigma_x \rangle_m = \langle \psi(\theta_m, \phi_m) | \sigma_x | \psi(\theta_m, \phi_m) \rangle$.

- k) For the case $L = 2$, show that $\langle \sigma_{1,x} \rangle = \langle \sigma_{2,x} \rangle = 0$ for all energy eigenvectors of the Hamiltonian \mathcal{H} .

26. **One-dimensional Hubbard model** - Consider a one-dimensional array containing L sites. The creation and annihilation operators corresponding to site $l \in \{1, 2, \dots, L\}$ with spin state $\sigma \in \{\uparrow, \downarrow\}$ are denoted by $a_{l,\sigma}^\dagger$ and $a_{l,\sigma}$, respectively. The operators $a_{l,\sigma}^\dagger$ and $a_{l,\sigma}$ satisfy Fermionic anti-commutation relations (16.8) and (16.9). The Hamiltonian \mathcal{H} is given by $\mathcal{H} = \mathcal{H}_0 + \mathcal{V}$, where the linear part \mathcal{H}_0 is

$$\begin{aligned} \mathcal{H}_0 = & -t \sum_{\sigma \in \{\uparrow, \downarrow\}} \sum_{l=1}^L \left(a_{l,\sigma}^\dagger a_{l+1,\sigma} + a_{l+1,\sigma}^\dagger a_{l,\sigma} \right) \\ & - m \sum_{\sigma \in \{\uparrow, \downarrow\}} \sum_{l=1}^L a_{l,\sigma}^\dagger a_{l,\sigma}, \end{aligned} \quad (18.478)$$

the on-site interaction term \mathcal{V} is

$$\mathcal{V} = U \sum_{l=1}^L \left(n_{l,\uparrow} - \frac{1}{2} \right) \left(n_{l,\downarrow} - \frac{1}{2} \right), \quad (18.479)$$

the real coefficients t , m and U are constants, and the Fermionic number operator $n_{l,\sigma}$ for spin state $\sigma \in \{\uparrow, \downarrow\}$ is given by [see Eq. (16.5)]

$$n_{l,\sigma} = a_{l,\sigma}^\dagger a_{l,\sigma}. \quad (18.480)$$

It is assumed that the array has a ring configuration, and thus, the last ($l = L$) hopping term $a_{l,\sigma}^\dagger a_{l+1,\sigma} + a_{l+1,\sigma}^\dagger a_{l,\sigma}$ [see Eq. (18.478)] is taken to be given by $a_{L,\sigma}^\dagger a_{1,\sigma} + a_{1,\sigma}^\dagger a_{L,\sigma}$.

- a) Show that for $\sigma \in \{\uparrow, \downarrow\}$, the total spin σ number operator n_σ , which is defined by

$$n_\sigma = \sum_{l=1}^L n_{l,\sigma} , \quad (18.481)$$

is a constant of the motion.

- b) Show that \mathcal{H}_0 can be expressed as

$$\mathcal{H}_0 = \sum_{\sigma} \Upsilon_{\sigma}^{\dagger} M \Upsilon_{\sigma} , \quad (18.482)$$

where the $L \times 1$ column vector Υ_{σ} is given by

$$\Upsilon_{\sigma} = \begin{pmatrix} a_{1\sigma} \\ a_{2\sigma} \\ a_{3\sigma} \\ \vdots \\ a_{L-1\sigma} \\ a_{L\sigma} \end{pmatrix} , \quad (18.483)$$

the $1 \times L$ row vector $\Upsilon_{\sigma}^{\dagger}$ is given by

$$\Upsilon_{\sigma}^{\dagger} = \left(a_{1\sigma}^{\dagger} a_{2\sigma}^{\dagger} a_{3\sigma}^{\dagger} \cdots a_{L-1\sigma}^{\dagger} a_{L\sigma}^{\dagger} \right) , \quad (18.484)$$

and the $L \times L$ matrix M by

$$M = - \begin{pmatrix} m & t & 0 & \vdots & 0 & t \\ t & m & t & \vdots & 0 & 0 \\ 0 & t & m & \vdots & 0 & 0 \\ \vdots & \vdots & \vdots & \ddots & \vdots & \vdots \\ 0 & 0 & 0 & \vdots & m & t \\ t & 0 & 0 & \vdots & t & m \end{pmatrix} . \quad (18.485)$$

- c) Show that

$$\mathcal{H}_0 = \sum_{\sigma} \sum_{l=1}^L \eta_l N_{l,\sigma} , \quad (18.486)$$

where the transformed number operator $N_{l,\sigma}$ is given by

$$N_{l,\sigma} = b_{l,\sigma}^{\dagger} b_{l,\sigma}$$

the transformed annihilation operator $b_{l,\sigma}$ by

$$b_{l,\sigma} = \sum_{l'=1}^L \frac{e^{-ik_l l'}}{\sqrt{L}} a_{l',\sigma}, \quad (18.487)$$

the energy η_l by [compare with Eq. (2.260)]

$$\eta_l = -m - 2t \cos k_l, \quad (18.488)$$

and the wave number k_l by [compare with Eq. (2.259)]

$$k_l = \frac{2\pi l}{L}. \quad (18.489)$$

The transformation inverse to (18.487) is given by

$$a_{l,\sigma} = \sum_{l'=1}^L \frac{e^{ik_l l'}}{\sqrt{L}} b_{l',\sigma}. \quad (18.490)$$

- d) Show that the transformed operators $b_{l,\sigma}^\dagger$ and $b_{l,\sigma}$ [see Eq. (18.487)] satisfy Fermionic anti-commutation relations (16.8) and (16.9).
 e) For the case $U = 0$, the total energy $E(l_\sigma)$ for spin state $\sigma \in \{\uparrow, \downarrow\}$ is defined by

$$E(l_\sigma) = \sum_{l=-l_\sigma}^{l_\sigma} \eta_l, \quad (18.491)$$

where the single-particle energy η_l is given by Eq. (18.488). Show that for integers $L \gg 1$ and $l_\sigma \gg 1$

$$E(l_\sigma) \simeq -2l_\sigma \left(m + 2t \frac{\sin \frac{2\pi l_\sigma}{L}}{\frac{2\pi l_\sigma}{L}} \right). \quad (18.492)$$

The energy density of states $D(\eta_F)$ per length (and per spin) is defined by

$$D(\eta_F) = \frac{1}{\eta_F L} \frac{dE}{d\eta_F}, \quad (18.493)$$

where η_F , which is given by [see Eq. (18.488)]

$$\eta_F = -m - 2t \cos \frac{2\pi l_\sigma}{L}, \quad (18.494)$$

is the largest energy occupied single-particle. Use the above result (18.492) to show that

$$D(\eta_F) = \frac{1}{\pi \sqrt{4t^2 - (\eta_F + m)^2}}. \quad (18.495)$$

- f) For the case $U = 0$, show that in thermal equilibrium at temperature T

$$\langle n_{i,\sigma} \rangle = \sum_{l=1}^L \frac{1}{e^{\beta \eta_l} + 1} , \quad (18.496)$$

where $\beta = 1/(k_B T)$, and k_B is Boltzmann's constant.

- g) Show that

$$\sum_{l=1}^L n_{l,\uparrow} n_{l,\downarrow} = \frac{1}{L} \sum_{l',l'',l''',l''''=1}^L b_{l''',\uparrow}^\dagger b_{l',\uparrow} b_{l''',\downarrow}^\dagger b_{l'',\downarrow} \delta_{l'+l'',l'''+l''''} . \quad (18.497)$$

- h) **Mean field approximation** - Formally, the coupling term $n_{l,\uparrow} n_{l,\downarrow}$ in Eq. (18.479) can be expressed as [compare with Eq. (18.304)]

$$\begin{aligned} n_{l,\uparrow} n_{l,\downarrow} &= (n_{l,\uparrow} - \langle n_{l,\uparrow} \rangle) (n_{l,\downarrow} - \langle n_{l,\downarrow} \rangle) \\ &\quad + n_{l,\uparrow} \langle n_{l,\downarrow} \rangle + \langle n_{l,\uparrow} \rangle n_{l,\downarrow} - \langle n_{l,\uparrow} \rangle \langle n_{l,\downarrow} \rangle . \end{aligned} \quad (18.498)$$

In the mean field approximation both terms $n_{l,\uparrow} - \langle n_{l,\uparrow} \rangle$ and $n_{l,\downarrow} - \langle n_{l,\downarrow} \rangle$ are considered as small. The mean field Hamiltonian \mathcal{H}_{MF} is derived from \mathcal{H} by disregarding the term $(n_{l,\uparrow} - \langle n_{l,\uparrow} \rangle) (n_{l,\downarrow} - \langle n_{l,\downarrow} \rangle)$ in Eq. (18.498), and by removing all constant terms

$$\begin{aligned} \mathcal{H}_{\text{MF}} &= -t \sum_{\sigma \in \{\uparrow, \downarrow\}} \sum_{l=1}^L \left(a_{l,\sigma}^\dagger a_{l+1,\sigma} + a_{l+1,\sigma}^\dagger a_{l,\sigma} \right) \\ &\quad - \sum_{l=1}^L (m_\uparrow n_{l,\uparrow} + m_\downarrow n_{l,\downarrow}) , \end{aligned} \quad (18.499)$$

where

$$m_\uparrow = m - U \left(\langle n_{l,\downarrow} \rangle - \frac{1}{2} \right) , \quad (18.500)$$

$$m_\downarrow = m - U \left(\langle n_{l,\uparrow} \rangle - \frac{1}{2} \right) . \quad (18.501)$$

It is assumed that the expectation values $\langle n_{l,\downarrow} \rangle$ and $\langle n_{l,\uparrow} \rangle$, which are expressed in terms of the averaged occupation n_0 and magnetization m as

$$\langle n_{l,\downarrow} \rangle = n_0 - m , \quad (18.502)$$

$$\langle n_{l,\uparrow} \rangle = n_0 + m , \quad (18.503)$$

are independent on site index l , and thus [see Eqs. (18.500) and (18.501)]

$$m_{\uparrow} = m - U \left(n_0 - \frac{1}{2} - m \right) , \quad (18.504)$$

$$m_{\downarrow} = m - U \left(n_0 - \frac{1}{2} + m \right) . \quad (18.505)$$

Note that the relations (18.502) and (18.503) imply that

$$\frac{m}{n_0} = \frac{\langle n_{l,\uparrow} \rangle - \langle n_{l,\downarrow} \rangle}{\langle n_{l,\uparrow} \rangle + \langle n_{l,\downarrow} \rangle} . \quad (18.506)$$

Consider the case where the averaged occupation n_0 is fixed. Show that the ground state energy is locally minimized for $m = 0$, i.e. for a vanishing magnetization, provided that the Stoner criterion, which is given by

$$LDU < 1 , \quad (18.507)$$

is satisfied, where LD is the energy density of states per spin [see Eq. (18.495)].

27. **Dicke model** - Consider a system composed of N TLSs interacting with a single cavity mode having angular frequency ω_e . Assume that all TLSs have the same energy spacing $\hbar\omega_a$ and the same coupling coefficient to the cavity mode, which is denoted by g_s . In the RWA the Hamiltonian of the system is taken to be given by [compare with Eq. (18.163)]

$$\begin{aligned} \hbar^{-1}\mathcal{H}_D &= \omega_e \left(A^\dagger A + \frac{1}{2} \right) + \frac{\omega_a}{2} \Sigma_z \\ &+ g_s (A^\dagger \Sigma_- + A \Sigma_+) , \end{aligned} \quad (18.508)$$

where the operators Σ_{\pm} and Σ_z are related to the single TLS operators $\Sigma_{\pm,n}$ and $\Sigma_{z,n}$ [see Eqs. (18.158), (18.159) and (18.160)] by

$$\Sigma_{\pm} = \sum_{n=1}^N \Sigma_{\pm,n} , \quad (18.509)$$

$$\Sigma_z = \sum_{n=1}^N \Sigma_{z,n} . \quad (18.510)$$

Assume that the single TLS operators $\Sigma_{\pm,n}$ and $\Sigma_{z,n}$ satisfy the commutation relations (18.191), (18.192) and (18.193) (which implies that the operators Σ_{\pm} and Σ_z satisfy the same relations). In the so-called Holstein-Primakoff transformation the operators Σ_{\pm} and Σ_z are expressed as

$$\Sigma_+ = B^\dagger (\mathcal{N} - B^\dagger B)^{1/2} , \quad (18.511)$$

$$\Sigma_- = (\mathcal{N} - B^\dagger B)^{1/2} B , \quad (18.512)$$

$$\Sigma_z = -\mathcal{N} + 2B^\dagger B , \quad (18.513)$$

where \mathcal{N} is a positive constant.

- a) Show that the operators Σ_\pm and Σ_z given by Eqs. (18.511), (18.512) and (18.513) satisfy the commutation relations (18.191), (18.192) and (18.193) provided that the operator B satisfies the following commutation relation

$$[B, B^\dagger] = 1 . \quad (18.514)$$

- b) Employ the following transformations

$$A = \alpha + a , \quad (18.515)$$

$$B = \beta + b , \quad (18.516)$$

where both α and β are complex constants, and express the Hamiltonian (18.508) in terms of the operators a and b .

- c) When $g_s = 0$, i.e. when the TLSs are decoupled from the cavity mode, in the ground state the cavity contains no photons and all TLSs occupy their lower energy state, i.e. $\langle A^\dagger A \rangle = 0$ and $\langle \Sigma_z \rangle = -N$. To describe the behavior of the coupled system when its state is expected to be close to the ground state of the decoupled system the constants \mathcal{N} , α and β are chosen to be given by

$$\mathcal{N} = N , \quad (18.517)$$

$$\alpha = \beta = 0 . \quad (18.518)$$

Employ the approximation

$$(N - B^\dagger B)^{1/2} \simeq N^{1/2} , \quad (18.519)$$

which is expected to hold provided that $N \gg 1$, and calculate the energy eigenvalues of the Hamiltonian \mathcal{H}_D .

18.9 Solutions

1. In classical mechanics a mass particle in a rotating frame experiences a force perpendicular to its velocity called the Coriolis force. For the present case the Coriolis force \mathbf{F}_Ω is taken to be given by

$$\mathbf{F}_\Omega = 2m_s^* \mathbf{v} \times \boldsymbol{\Omega} , \quad (18.520)$$

where $\boldsymbol{\Omega} = \Omega \hat{\mathbf{z}}$ is the rotation vector and where $\mathbf{v} = \dot{\mathbf{r}}$ is the velocity vector. Additional force perpendicular to the velocity, which is acting in the presence of a magnetic field \mathbf{B} , is the Lorentz force $\mathbf{F}_L = \frac{q_s^*}{c} \mathbf{v} \times \mathbf{B}$ [see

Eq. (18.4)]. From this point of view the effect of rotation can be taken into account by replacing the magnetic field \mathbf{B} by an effective magnetic field \mathbf{B}_{eff} given by

$$\mathbf{B}_{\text{eff}} = \mathbf{B} + \frac{2m_s^*c}{q_s^*}\Omega . \quad (18.521)$$

With this approach Eq. (18.25) (for time independent \mathbf{B}) becomes

$$\nabla^2\mathbf{B} = \frac{1}{\lambda_L^2} \left(\mathbf{B} + \frac{2m_s^*c}{q_s^*}\Omega \right) . \quad (18.522)$$

Thus the magnetic field deep inside the superconductor is given by $-(2m_s^*c/q_s^*)\Omega$.

2. The total energy of the system in steady state is given by $E = T + U_H$, where

$$T = \int_V \frac{nm\mathbf{v}^2}{2} dV$$

is the kinetic energy and where

$$U_H = \frac{1}{8\pi} \int_V \mathbf{H}^2 dV \quad (18.523)$$

is the magnetic energy [see Eq. (14.42)]. With the help of the Maxwell's equation (18.223) and Eq. (18.254) E can be expressed in terms of \mathbf{H} as

$$E = \frac{1}{8\pi} \int_V \left[\lambda_L^2 (\nabla \times \mathbf{H})^2 + \mathbf{H}^2 \right] dV . \quad (18.524)$$

Let $\delta\mathbf{H}$ be an infinitesimally small change in \mathbf{H} , and let δE be the corresponding change in the energy. The requirement that E obtains a minimum value leads to

$$0 = \delta E = \frac{1}{4\pi} \int_V \left[\lambda_L^2 (\nabla \times \mathbf{H}) \cdot (\nabla \times \delta\mathbf{H}) + \mathbf{H} \cdot \delta\mathbf{H} \right] dV . \quad (18.525)$$

With the help of the general vector identity [see Eq. (14.45)]

$$\nabla \cdot (\mathbf{F}_1 \times \mathbf{F}_2) = (\nabla \times \mathbf{F}_1) \cdot \mathbf{F}_2 - \mathbf{F}_1 \cdot (\nabla \times \mathbf{F}_2) , \quad (18.526)$$

one finds (for the case where \mathbf{F}_1 and \mathbf{F}_2 are taken to be given by $\mathbf{F}_1 = \nabla \times \mathbf{H}$ and $\mathbf{F}_2 = \delta\mathbf{H}$) that

$$(\nabla \times \mathbf{H}) \cdot (\nabla \times \delta\mathbf{H}) = (\nabla \times (\nabla \times \mathbf{H})) \cdot \delta\mathbf{H} - \nabla \cdot (\nabla \times \mathbf{H} \times \delta\mathbf{H}) . \quad (18.527)$$

The vector identity $\nabla \times (\nabla \times \mathbf{H}) = \nabla (\nabla \cdot \mathbf{H}) - \nabla^2\mathbf{H}$ together with the Maxwell's equation (18.226) lead to

$$(\nabla \times \mathbf{H}) \cdot (\nabla \times \delta \mathbf{H}) = -(\nabla^2 \mathbf{H}) \cdot \delta \mathbf{H} - \nabla \cdot (\nabla \times \mathbf{H} \times \delta \mathbf{H}) . \quad (18.528)$$

The volume integral over the second term on the right hand side can be expressed as a surface integral using the divergence theorem. However, when boundary conditions of $\delta \mathbf{H} = \mathbf{0}$ on the surfaces are applied the surface integral vanishes. Thus Eq. (18.525) becomes

$$0 = \delta E = \frac{1}{4\pi} \int_V (-\lambda_L^2 \nabla^2 \mathbf{H} + \mathbf{H}) \cdot \delta \mathbf{H} \, dV . \quad (18.529)$$

The requirement that δE vanishes for arbitrary (small) $\delta \mathbf{H}$ leads to Eq. (18.421). The assumption that $\mathbf{B} = \mu \mathbf{H}$ [see Eq. (18.231)], i.e. the assumption that the medium is isotropic and linear, implies that in steady state Eq. (18.421) is equivalent to the 2nd London equation (18.25).

3. In the limit where the London penetration depth vanishes, \mathbf{B} vanishes everywhere inside the sphere (Meissner effect). Anywhere outside the sphere $\nabla \times \mathbf{B} = 0$ [see Eqs. (18.223) and (18.231)], hence \mathbf{B} can be expressed in terms of a scalar function φ as $\mathbf{B} = \nabla \varphi$. The Maxwell's equation $\nabla \cdot \mathbf{B} = 0$ (18.226) implies that $\nabla^2 \varphi = 0$. The boundary condition $\hat{\mathbf{r}} \cdot \mathbf{B} = \mathbf{0}$ must be satisfied on the sphere surface, and the condition $\mathbf{B} = \mathbf{H}$ must be satisfied far from the sphere [see Eq. (18.231)]. In spherical coordinates (r, θ, ϕ) , the unit vector $\hat{\mathbf{z}}$ can be expressed as $\hat{\mathbf{z}} = \nabla(r \cos \theta) = \hat{\mathbf{r}} \cos \theta - \hat{\boldsymbol{\theta}} \sin \theta$ [see Eq. (7.124)], and thus $\mathbf{H} = H \hat{\mathbf{z}}$ can be expressed as $\mathbf{H} = \nabla \varphi_H$, where $\varphi_H = Hr \cos \theta$. Consider a solution having the form $\varphi(r, \theta, \phi) = \varphi_H + f(r) Y_l^m(\theta, \phi)$, where $Y_l^m(\theta, \phi)$ is a spherical harmonic function (the sphere center is at $r = 0$). With the help of Eqs. (6.109), (7.19) and (6.89) one finds that

$$\nabla^2 \varphi = \left(\frac{1}{r} \frac{d^2(rf)}{dr^2} - \frac{l(l+1)f}{r^2} \right) Y_l^m , \quad (18.530)$$

and with the help of Eqs. (7.124) and (6.117) one finds that

$$\nabla \varphi = \left(\hat{\mathbf{r}} \cos \theta - \hat{\boldsymbol{\theta}} \sin \theta \right) H + \hat{\mathbf{r}} \frac{\partial f}{\partial r} Y_l^m + \left(\hat{\boldsymbol{\theta}} \frac{1}{r} \frac{\partial Y_l^m}{\partial \theta} + \hat{\boldsymbol{\phi}} \frac{im Y_l^m}{r \sin \theta} \right) f . \quad (18.531)$$

The condition $\nabla^2 \varphi = 0$ can be satisfied by choosing $f(r) = \sqrt{\pi/3} H R^3 r^{-2}$, $l = 1$ and $m = 0$ [see Eq. (18.530) and (6.132)]. For this choice Eq. (18.531) yields

$$\mathbf{B} = \nabla \varphi = H \left[\hat{\mathbf{r}} \left(1 - \frac{R^3}{r^3} \right) \cos \theta - \hat{\boldsymbol{\theta}} \left(1 + \frac{R^3}{2r^3} \right) \sin \theta \right] . \quad (18.532)$$

Note that both conditions, $\hat{\mathbf{r}} \cdot \mathbf{B} = \mathbf{0}$ on the sphere surface, and $\mathbf{B} = \mathbf{H}$ far from the sphere ($r/R \rightarrow \infty$), are satisfied by Eq. (18.532).

4. The total magnetic flux ϕ_1 (ϕ_2) threading the upper (lower) loop is given by [see Eq. (18.75) and Fig. 18.11]

$$\phi_1 = \phi_{e1} + A_1 I_{s1} , \quad (18.533)$$

$$\phi_2 = \phi_{e2} + A_2 I_{s2} , \quad (18.534)$$

where ϕ_1 (ϕ_2) is the total magnetic flux in the upper (lower) loop, I_{s1} (I_{s2}) is the circulating current flowing in the upper (lower) loop and mutual inductance between the loops is disregarded. The requirement that the phase of the macroscopic wavefunction is continuous in both the upper and lower loops yields the following relations [see Eq. (18.72)]

$$\Theta + \frac{2\pi\phi_1}{\phi_s} = 2n_1\pi , \quad (18.535)$$

$$-\Theta + \frac{2\pi\phi_2}{\phi_s} = 2n_2\pi , \quad (18.536)$$

where Θ is the gauge invariant phase difference across the junction, ϕ_s is the flux quantum and where both n_1 and n_2 are integers. The Lagrangian of the system can be expressed as a function of the dimensionless flux coordinates Φ , which is defined by [see Eqs. (18.535) and (18.536)]

$$\Phi = 2\pi \left(\frac{\phi_1}{\phi_s} - n_1 \right) = -2\pi \left(\frac{\phi_2}{\phi_s} - n_2 \right) = -\Theta , \quad (18.537)$$

and its time derivative $\dot{\Phi}$ [see Eq. (18.82)]

$$\mathcal{L} = \frac{C_J \phi_s^2 \dot{\Phi}^2}{8\pi^2 c^2} - \frac{\phi_s^2 (\Phi - \Phi_{e1})^2}{8\pi^2 c A_1} - \frac{\phi_s^2 (\Phi + \Phi_{e2})^2}{8\pi^2 c A_2} + \frac{\phi_s I_c}{2\pi c} \cos \Phi , \quad (18.538)$$

where

$$\Phi_{e1} = \frac{2\pi\phi_{e1}}{\phi_s} - 2\pi n_1 , \quad (18.539)$$

$$\Phi_{e2} = \frac{2\pi\phi_{e2}}{\phi_s} - 2\pi n_2 , \quad (18.540)$$

are the normalized external fluxes. Using the notation

$$\frac{1}{\Lambda_0} = \frac{1}{\Lambda_1} + \frac{1}{\Lambda_2} , \quad (18.541)$$

$$\Phi_{e0} = \frac{\Lambda_0 \Phi_{e1}}{\Lambda_1} - \frac{\Lambda_0 \Phi_{e2}}{\Lambda_2} , \quad (18.542)$$

the Lagrangian can be expressed as

$$\mathcal{L} = \frac{C_J \phi_s^2 \dot{\Phi}^2}{8\pi^2 c^2} - \frac{\phi_s^2 (\Phi - \Phi_{e0})^2}{8\pi^2 c \Lambda_0} + \frac{\phi_s I_c}{2\pi c} \cos \Phi + C_G , \quad (18.543)$$

where the constant C_G is given by

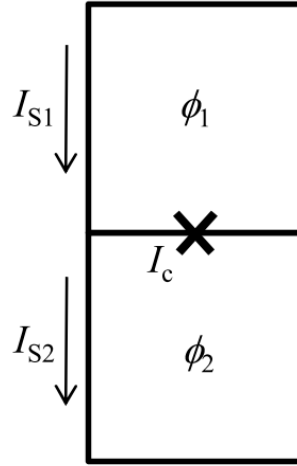

Fig. 18.11. Gradiometer RF SQUID.

$$C_G = -\frac{\phi_s^2 \left(\frac{\Lambda_0}{A_1} \Phi_{e1}^2 + \frac{\Lambda_0}{A_2} \Phi_{e2}^2 - \Phi_{e0}^2 \right)}{8\pi^2 c \Lambda_0}. \quad (18.544)$$

The resulting Euler - Lagrange equation of motion (1.8) is given by

$$\frac{d}{dt} \left(\frac{\partial \mathcal{L}}{\partial \dot{\Phi}} \right) = \frac{\partial \mathcal{L}}{\partial \Phi}, \quad (18.545)$$

thus

$$\frac{C_J \phi_s \ddot{\Phi}}{2\pi c} = -\frac{\phi_s (\Phi - \Phi_{e0})}{2\pi \Lambda_0} - I_c \sin \Phi. \quad (18.546)$$

Note that [see Eqs. (18.533) and (18.534)]

$$\Phi - \Phi_{e0} = \frac{2\pi \Lambda_0 (I_{s1} - I_{s2})}{\phi_s}, \quad (18.547)$$

thus with the help of Eqs. (18.58) and (18.537) the equation of motion (18.546) can be expressed as a current conservation law [compare with Eq. (18.90)]

$$I_{s1} - I_{s2} = I_c \sin \Theta + C_J \dot{V}, \quad (18.548)$$

where V is the voltage across the Josephson junction.

5. The negative terminal of the voltage source V_g is taken to be a ground node, i.e. its potential is assumed to vanish. The Lagrangian \mathcal{L} is expressed as a function of the flux variable ϕ and its time derivative $\dot{\phi}$ of

the node between the capacitor C_g and the Josephson junction (this node is commonly called the island). The flux variable of the node between the positive terminal of the voltage source and the capacitor C_g is taken to be given by $cV_g t$ (recall that, in general a node flux variable is defined by $\phi(t) = c \int^t dt' V(t')$, where $V(t')$ is the node voltage at time t' with respect to the ground node). The Lagrangian \mathcal{L} is thus given by

$$\mathcal{L} = \frac{C_g (\dot{\phi} - cV_g)^2}{2c^2} + \frac{C_J \dot{\phi}^2}{2c^2} + \frac{\phi_s I_c}{2\pi c} \cos \frac{2\pi\phi}{\phi_s},$$

or, in terms of the dimensionless coordinate $\Phi = 2\pi\phi/\phi_s$

$$\mathcal{L} = \frac{C_g \left(\frac{\phi_s \dot{\Phi}}{2\pi} - cV_g \right)^2}{2c^2} + \frac{C_J \phi_s^2 \dot{\Phi}^2}{8\pi^2 c^2} + E_J \cos \Phi,$$

where

$$E_J = \frac{\phi_s I_c}{2\pi c}. \quad (18.549)$$

The corresponding Euler - Lagrange equation (1.8)

$$\frac{d}{dt} \left(\frac{\partial \mathcal{L}}{\partial \dot{\Phi}} \right) = \frac{\partial \mathcal{L}}{\partial \Phi}, \quad (18.550)$$

which yields

$$C_J \frac{\phi_s \ddot{\Phi}}{2\pi c} + I_c \sin \Phi = C_g \left(\dot{V}_g - \frac{\phi_s \ddot{\Phi}}{2\pi c} \right), \quad (18.551)$$

or

$$C_J \dot{V}_J + I_c \sin \Phi = C_g (\dot{V}_g - \dot{V}_J), \quad (18.552)$$

where $V_J = \phi_s \dot{\Phi}/2\pi c$, expresses the law of current conservation. The variable canonically conjugate to Φ is defined by [see Eq. (1.20)]

$$P = \frac{\partial \mathcal{L}}{\partial \dot{\Phi}} = \frac{\phi_s}{2\pi c} q_i, \quad (18.553)$$

where q_i , which is given by

$$q_i = C_J \frac{\phi_s \dot{\Phi}}{2\pi c} - C_g \left(V_g - \frac{\phi_s \dot{\Phi}}{2\pi c} \right) = C_J V_J - C_g (V_g - V_J), \quad (18.554)$$

is the charge trapped in the island. Using the definition (1.22) one finds that the Hamiltonian \mathcal{H} can be expressed as a function of Φ and P as

$$\mathcal{H} = \frac{\left(\frac{2\pi c}{\phi_s} P + C_g V_g\right)^2}{2C_\Sigma} - E_J \cos \Phi - \frac{V_g^2 C_g}{2}, \quad (18.555)$$

where C_Σ , which is given by

$$C_\Sigma = C_J + C_g, \quad (18.556)$$

is the total capacitance of the island.

6. When constant terms are disregarded the Hamiltonian (18.555) becomes

$$\mathcal{H} = \frac{2\pi^2 c^2}{\phi_s^2 C_\Sigma} (P + p_0)^2 + E_J \left(\frac{\Phi^2}{2} - \frac{\Phi^4}{24} \right), \quad (18.557)$$

where the constant p_0 is given by

$$p_0 = \frac{\phi_s C_g V_g}{2\pi c}, \quad (18.558)$$

or

$$\mathcal{H} = \frac{(P + p_0)^2}{2\mu} + \frac{\mu\omega_p^2}{2} \left(\Phi^2 - \frac{\Phi^4}{12} \right), \quad (18.559)$$

where

$$\mu = \frac{\phi_s^2 C_\Sigma}{4\pi^2 c^2} = \frac{E_J}{\omega_p^2}, \quad (18.560)$$

$$\omega_p^2 = \frac{4\pi^2 c^2 E_J}{\phi_s^2 C_\Sigma} = \frac{1}{L_J C_\Sigma}, \quad (18.561)$$

and where $L_J = \phi_s / (2\pi c I_c)$ is the Josephson inductance [recall that $E_J = \phi_s I_c / (2\pi c)$, and see Eqs. (18.63) and (18.66)]. With the help of Eq. (2.182) and the commutation relation $[\Phi, P] = i\hbar$ [see Eq. (3.9)] one finds that [compare with Eq. (12.54)]

$$UPU^\dagger = P + p_0, \quad (18.562)$$

where the unitary operator U is given by

$$U = e^{-\frac{ip_0\Phi}{\hbar}}. \quad (18.563)$$

The transformed Hamiltonian $\mathcal{H}' = U^\dagger \mathcal{H} U$, which is given by

$$\mathcal{H}' = \mathcal{H}_0 - \frac{E_J}{24} \Phi^4, \quad (18.564)$$

where

$$\mathcal{H}_0 = \frac{P^2}{2\mu} + \frac{\mu\omega_p^2 \Phi^2}{2}, \quad (18.565)$$

has the same energy eigenvalues as the Hamiltonian \mathcal{H} . In terms of the annihilation a and creation a^\dagger operators the harmonic oscillator Hamiltonian \mathcal{H}_0 is expressed as [see Eqs. (5.9), (5.10), (5.11) and (5.16)]

$$\mathcal{H}_0 = \hbar\omega_p \left(a^\dagger a + \frac{1}{2} \right), \quad (18.566)$$

where

$$a = \sqrt{\frac{\mu\omega_p}{2\hbar}} \left(\Phi + \frac{iP}{\mu\omega_p} \right), \quad (18.567)$$

and the perturbation term is expressed as

$$-\frac{E_J}{24}\Phi^4 = -\frac{\hbar^2 E_J}{96\mu^2\omega_p^2} (a + a^\dagger)^4 = -\frac{(\hbar\omega_p)^2}{96E_J} (a + a^\dagger)^4. \quad (18.568)$$

The following holds [see Eq. (5.16)]

$$\mathcal{H}_0 |n\rangle = \hbar\omega_p \left(n + \frac{1}{2} \right) |n\rangle, \quad (18.569)$$

and [see Eqs. (5.28), (5.29) and (5.13)]

$$\langle n | (a + a^\dagger)^4 | n \rangle = 6n^2 + 6n + 3, \quad (18.570)$$

where $\{|n\rangle\}$ are energy eigenvectors of \mathcal{H}_0 , hence to first order in perturbation theory [see Eq. (9.32)]

$$\frac{E_1 - E_0}{\hbar} = \omega_p \left(1 - \frac{\hbar\omega_p}{8E_J} \right), \quad (18.571)$$

$$\frac{E_2 - E_1}{\hbar} = \omega_p \left(1 - \frac{\hbar\omega_p}{4E_J} \right). \quad (18.572)$$

7. The kinetic T and potential U energies are expressed by Eqs. (18.209) and (18.213), respectively, as a function of the node flux variables ϕ_1 and ϕ_2 . The coordinate transformation

$$\phi_+ = \frac{\phi_1 + \phi_2}{2}, \quad (18.573)$$

$$\phi_- = \frac{\phi_1 - \phi_2}{2}, \quad (18.574)$$

yields a DC SQUID kinetic energy T [see Eq. (18.209)]

$$T = \frac{C_J \left(\dot{\phi}_+^2 + \dot{\phi}_-^2 \right)}{c^2}, \quad (18.575)$$

and a DC SQUID potential energy given by $U = U_0 u$ [see Eq. (18.213)], where the constant U_0 is given by

$$U_0 = \frac{\phi_s I_c}{2\pi c}, \quad (18.576)$$

the dimensionless potential u is given by [note that the constant term $I_b \phi_e / (2c)$ has been disregarded, and recall that $\cos(x \pm y) = \cos x \cos y \mp \sin x \sin y$]

$$u = -\cos \frac{2\pi\phi_+}{\phi_s} \cos \frac{2\pi\phi_-}{\phi_s} + \alpha \sin \frac{2\pi\phi_+}{\phi_s} \sin \frac{2\pi\phi_-}{\phi_s} - \frac{2\pi I_b}{I_c} \frac{\phi_+}{\phi_s} + \frac{2 \left(\frac{2\pi\phi_-}{\phi_s} + \frac{\pi\phi_e}{\phi_s} \right)^2}{\beta_L}, \quad (18.577)$$

and where

$$I_{c1} + I_{c2} = I_c, \quad (18.578)$$

$$I_{c1} - I_{c2} = \alpha I_c. \quad (18.579)$$

In the limit $\beta_L \equiv 2\pi \Lambda I_c / \phi_s \ll 1$ the inductive energy of the loop $2 \left(2\pi\phi_- / \phi_s + \pi\phi_e / \phi_s \right)^2 / \beta_L$, which depends only on the coordinate ϕ_- , becomes large, unless $\phi_- = -\phi_e/2$. The one-dimensional potential, which is defined by $u_+(\phi_+) = u(\phi_+, -\phi_e/2)$, is given by

$$u_+ = -\cos \frac{2\pi\phi_+}{\phi_s} \cos \frac{\pi\phi_e}{\phi_s} - \alpha \sin \frac{2\pi\phi_+}{\phi_s} \sin \frac{\pi\phi_e}{\phi_s} - \frac{2\pi I_b}{I_c} \frac{\phi_+}{\phi_s} = -i_c \left(\frac{\cos \frac{\pi\phi_e}{\phi_s}}{i_c} \cos \frac{2\pi\phi_+}{\phi_s} + \frac{\alpha \sin \frac{\pi\phi_e}{\phi_s}}{i_c} \sin \frac{2\pi\phi_+}{\phi_s} \right) - \frac{2\pi I_b}{I_c} \frac{\phi_+}{\phi_s}, \quad (18.580)$$

where

$$i_c = \sqrt{\cos^2 \frac{\pi\phi_e}{\phi_s} + \alpha^2 \sin^2 \frac{\pi\phi_e}{\phi_s}} = \sqrt{1 - (1 - \alpha^2) \sin^2 \frac{\pi\phi_e}{\phi_s}}, \quad (18.581)$$

hence [recall that $\cos(x - y) = \cos x \cos y + \sin x \sin y$]

$$u_+ = -i_c \cos \left(\frac{2\pi\phi_+}{\phi_s} - \theta \right) - \frac{2\pi I_b}{I_c} \frac{\phi_+}{\phi_s}, \quad (18.582)$$

where

$$\theta = \tan^{-1} \left(\alpha \tan \frac{\pi\phi_e}{\phi_s} \right). \quad (18.583)$$

The equation

$$0 = \frac{du_+}{d\phi_+} = \frac{2\pi}{\phi_s} \left(i_c \sin \left(\frac{2\pi\phi_+}{\phi_s} - \theta \right) - \frac{I_b}{I_c} \right), \quad (18.584)$$

has no solution when $I_b > I_{b,c}$, where the critical current $I_{b,c}$ is given by

$$I_{b,c} = I_c i_c = I_c \sqrt{1 - (1 - \alpha^2) \sin^2 \frac{\pi \phi_e}{\phi_s}}. \quad (18.585)$$

8. The extremum points of the DC-SQUID potential are found by solving

$$0 = \frac{\partial u}{\partial \gamma_+} = \sin \gamma_+ \cos \gamma_- + \alpha \cos \gamma_+ \sin \gamma_- - \frac{I_b}{I_c}, \quad (18.586)$$

$$0 = \frac{\partial u}{\partial \gamma_-} = \cos \gamma_+ \sin \gamma_- + \alpha \sin \gamma_+ \cos \gamma_- + \frac{4 \left(\gamma_- + \frac{\pi \phi_e}{\phi_s} \right)}{\beta_L}. \quad (18.587)$$

a) The Hessian matrix is given by

$$H = \begin{pmatrix} \cos \gamma_+ \cos \gamma_- - \alpha \sin \gamma_+ \sin \gamma_- & -\sin \gamma_+ \sin \gamma_- + \alpha \cos \gamma_+ \cos \gamma_- \\ -\sin \gamma_+ \sin \gamma_- + \alpha \cos \gamma_+ \cos \gamma_- & \cos \gamma_+ \cos \gamma_- - \alpha \sin \gamma_+ \sin \gamma_- + \frac{4}{\beta_L} \end{pmatrix}. \quad (18.588)$$

In the limit $\beta_L \rightarrow \infty$

$$\begin{aligned} \det H &= (1 - \alpha^2) (\cos^2 \gamma_+ - \sin^2 \gamma_-) \\ &= (1 - \alpha^2) \cos \gamma_1 \cos \gamma_2, \end{aligned} \quad (18.589)$$

and

$$\begin{aligned} \text{Tr } H &= 2 (\cos \gamma_+ \cos \gamma_- - \alpha \sin \gamma_+ \sin \gamma_-) \\ &= (1 + \alpha) \cos \gamma_1 + (1 - \alpha) \cos \gamma_2, \end{aligned} \quad (18.590)$$

where $\gamma_{\pm} = (\gamma_1 \pm \gamma_2)/2$.

b) The square vertices (γ_1, γ_1) coordinates are $(\pi/2, \pi/2)$, $(\pi/2, -\pi/2)$, $(-\pi/2, -\pi/2)$ and $(-\pi/2, \pi/2)$. Inside the square $\text{Tr } H > 0$ [see Eq. (18.590)] and $\det H = 0$ [see Eq. (18.589)] along its edges.

c) The relations (18.586) and (18.587) can be rewritten as (recall that it is assumed that $\beta_L \gg 1$)

$$p_b = \sin \gamma_+ \cos \gamma_- + \alpha \cos \gamma_+ \sin \gamma_-, \quad (18.591)$$

$$p_e = -\cos \gamma_+ \sin \gamma_- - \alpha \sin \gamma_+ \cos \gamma_-, \quad (18.592)$$

or

$$p_b = \frac{(1 + \alpha) \sin (\gamma_+ + \gamma_-) + (1 - \alpha) \sin (\gamma_+ - \gamma_-)}{2}, \quad (18.593)$$

$$p_e = \frac{(-1 - \alpha) \sin (\gamma_+ + \gamma_-) + (1 - \alpha) \sin (\gamma_+ - \gamma_-)}{2}, \quad (18.594)$$

or [recall that $\gamma_{\pm} = (\gamma_1 \pm \gamma_2) / 2$]

$$p_b = \frac{(1 + \alpha) \sin \gamma_1 + (1 - \alpha) \sin \gamma_2}{2}, \quad (18.595)$$

$$p_e = \frac{(-1 - \alpha) \sin \gamma_2 + (1 - \alpha) \sin \gamma_1}{2}, \quad (18.596)$$

thus the bounding contour in the plane of normalized control parameters (p_b, p_e) has a rectangle shape, with vertices $(1, -\alpha)$, $(\alpha, -1)$, $(-1, \alpha)$ and $(-\alpha, 1)$ (recall that it is assumed that $\beta_L \equiv 2\pi \Lambda I_c / \phi_s \gg 1$).

- d) For local minima points of the potential u , both eigenvalues of H are positive, and thus $\det H > 0$ and $\text{tr } H > 0$. Thus the conditions $\det H = 0$ and $\text{tr } H > 0$ determine the boundaries of the stability regions of minima points of the potential u in the plane of the coordinates. Consider the local minima point at $(\gamma_+, \gamma_-) = (0, 0)$ of the potential u with control parameters $(p_b, p_e) = (0, 0)$. The bounding contour in the (p_b, p_e) plane determines the stability region, inside which this local extrema point remains stable.
9. The total magnetic flux ϕ threading the loop is given by [compare with Eq. (18.75)]

$$\phi = \phi_e + \Lambda I_s + Bl_m x, \quad (18.597)$$

where I_s is the current circulating in the loop.

- a) The Lagrangian $\mathcal{L}(\phi, x, \dot{\phi}, \dot{x})$ is given by [compare with Eq. (18.82)]

$$\mathcal{L} = \frac{m\dot{x}^2}{2} + \frac{C_J \dot{\phi}^2}{2c^2} - U(\phi, x), \quad (18.598)$$

where the potential energy U is given by

$$U = \frac{m\omega_m^2 x^2}{2} + \frac{(\phi - \phi_e - Bl_m x)^2}{2c\Lambda} - \frac{\phi_s I_c}{2\pi c} \cos \frac{2\pi\phi}{\phi_s}, \quad (18.599)$$

and ϕ_s is the flux quantum. The resulting Euler - Lagrange equations are given by

$$-\frac{\phi - \phi_e - Bl_m x}{\Lambda} - I_c \sin \frac{2\pi\phi}{\phi_s} = \frac{C_J \ddot{\phi}}{c}, \quad (18.600)$$

$$-m\omega_m^2 x + \frac{Bl_m (\phi - \phi_e - Bl_m x)}{c\Lambda} = m\ddot{x}. \quad (18.601)$$

In terms of the gauge invariant phase across the Josephson junction γ_J , which is given by

$$\gamma_J = 2\pi n - \frac{2\pi\phi}{\phi_s}, \quad (18.602)$$

where n is an integer, the Euler - Lagrange equations can be rewritten as [note that $\phi - \phi_e - Bl_m x = AI_s$, see Eq. (18.597)]

$$m\ddot{x} + m\omega_m^2 x - \frac{Bl_m I_s}{c} = 0, \quad (18.603)$$

and

$$I_c \sin \gamma_J + C_J \frac{\phi_s}{2\pi c} \dot{\gamma}_J = I_s. \quad (18.604)$$

The Euler - Lagrange Eq. (18.603) expresses Newton's second law, where the force is composed of the restoring mechanical force $-m\omega_m^2 x$ and the Lorentz force $c^{-1}Bl_m I_s$ acting on the movable beam, whereas Eq. (18.604) states that the circulating current I_s equals the sum of the current $I_c \sin \gamma_J$ through the Josephson junction and the current $C_J \dot{V}_J$ through the capacitor, where the voltage V_J is given by the second Josephson equation $V_J = (\phi_s/2\pi c) \dot{\gamma}_J$ [see Eq. (18.58)].

- b) The variables canonically conjugate to x and ϕ are $p = \partial\mathcal{L}/\partial\dot{x} = m\dot{x}$ and $Q = \partial\mathcal{L}/\partial\dot{\phi} = c^{-2}C_J\dot{\phi}$ respectively. The Hamiltonian is given by

$$\mathcal{H} = \frac{p^2}{2m} + \frac{c^2 Q^2}{2C_J} + U(\phi, x).$$

Quantization is achieved by regarding the variables x , p , ϕ and Q as Hermitian operators satisfying the following commutation relations $[x, p] = [\phi, Q] = i\hbar$ and $[x, \phi] = [x, Q] = [p, \phi] = [p, Q] = 0$.

10. Integration of the current density \mathbf{J}_s over a general closed curve \mathcal{C} yields [see Eq. (18.67) and (18.71)]

$$\oint_{\mathcal{C}} \mathbf{dr} \cdot \nabla \theta_{GI} = \oint_{\mathcal{C}} \mathbf{dr} \cdot \nabla \theta - \frac{2\pi}{\phi_s} \oint_{\mathcal{C}} \mathbf{dr} \cdot \mathbf{A}. \quad (18.605)$$

The requirement that the macroscopic wavefunction is continuous yields

$$\oint_{\mathcal{C}} \mathbf{dr} \cdot \nabla \theta_{GI} = 2\pi n - \frac{2\pi\phi}{\phi_s}, \quad (18.606)$$

where n is integer, and ϕ is the magnetic flux threading the closed curve \mathcal{C} . Let $\Theta(x, y)$ be the junction phase difference [i.e. the change in the gauge invariant phase θ_{GI} across the junction at point (x, y)] [compare with Eq. (18.69)]. With the help of Eq. (18.606) one finds that $\Theta(x, y) = \Theta_0 + \kappa x$, where Θ_0 is the value of Θ at $x = 0$. The total current I_J is given by [see Eq. (18.56)]

$$\begin{aligned}
 I_J &= J_c \int_{-\frac{L_x}{2}}^{\frac{L_x}{2}} dx \int_{-\frac{L_y}{2}}^{\frac{L_y}{2}} dy \sin \Theta \\
 &= J_c L_y \int_{-\frac{L_x}{2}}^{\frac{L_x}{2}} dx \sin (\Theta_0 + \kappa x) \\
 &= J_c L_x L_y \frac{\sin \frac{\kappa L_x}{2}}{\frac{\kappa L_x}{2}} \sin \Theta_0,
 \end{aligned} \tag{18.607}$$

where J_c is the junction critical current density. The current is maximized when $\sin \Theta_0 = 1$, and thus Eq. (18.426) holds.

11. The initial state $|\curvearrowright\rangle$ yields the expectation value $\langle \Sigma_x \rangle_i = 1$. After the first measurement the flux qubit collapses to the state $|+\rangle$ ($|-\rangle$) with probability 0.5 (0.5). The following holds $\langle + | \Sigma_x | + \rangle = \langle - | \Sigma_x | - \rangle = 0$, hence the final expectation value is given by $\langle \Sigma_x \rangle_f = 0$, and thus angular momentum is apparently not conserved. Note that typically in the states $|\curvearrowright\rangle$ or $|\curvearrowleft\rangle$ the angular momentum carried by a flux qubit circulating current is of the order of $10^7 \hbar$. This example demonstrates that the non-unitary nature of quantum state collapse may lead to violation of conservation laws. In this particular example, the assumption that non-invasive measurements can be performed on the flux qubit by the LC resonator and by the DC SQUID is invalid.
12. For $\phi_e = \phi_s/2$, the qubit energy eigenstates $|+\rangle$ and $|-\rangle$ are related to the circulating current states $|\curvearrowright\rangle$ and $|\curvearrowleft\rangle$ by [see Eq. (18.152)]

$$\begin{pmatrix} |+\rangle \\ |-\rangle \end{pmatrix} = \begin{pmatrix} \frac{1}{\sqrt{2}} & \frac{1}{\sqrt{2}} \\ -\frac{1}{\sqrt{2}} & \frac{1}{\sqrt{2}} \end{pmatrix} \begin{pmatrix} |\curvearrowright\rangle \\ |\curvearrowleft\rangle \end{pmatrix}, \tag{18.608}$$

and the corresponding eigenenergies are $\varepsilon_{\pm} = \mp \hbar \omega_{\Delta} / 2$ [see Eq. (18.154)]. The operator $\Sigma_x = |\curvearrowright\rangle \langle \curvearrowright| - |\curvearrowleft\rangle \langle \curvearrowleft|$ in the qubit energy eigenstates basis is given by $\Sigma_x = |+\rangle \langle -| + |-\rangle \langle +|$. In the same basis the initial state $|\psi\rangle (t=0) = |\curvearrowright\rangle \otimes |\alpha\rangle$ is expressed as $|\psi\rangle (t=0) = 2^{-1/2} (|+\rangle + |-\rangle) \otimes |\alpha\rangle$. The effective angular resonance frequency of the LC resonator $\omega_{e\pm}$ with a flux qubit occupying the energy eigenstate state $|\mp\rangle$ is given by $\omega_{e\pm} = \omega_e \pm \omega_{BS} \mp g_1^2 / \Delta + O(g_1^4)$ [see Eqs. (18.188) and (18.189)]. Recall that, for a harmonic oscillator having angular frequency ω_e , a coherent state $|\alpha_0\rangle$ at time $t=0$, where α_0 is complex, evolves into a coherent state $e^{-i\omega_e t/2} |\alpha = \alpha_0 e^{-i\omega_e t}\rangle$ at time t [see Eq. (5.53)]. The above results together with Eqs. (18.427) and (5.252) yields to lowest nonvanishing order in g (note that $\langle + | \Sigma_x | + \rangle = \langle - | \Sigma_x | - \rangle = 0$ and $\langle + | \Sigma_x | - \rangle = \langle - | \Sigma_x | + \rangle = 1$)

$$\begin{aligned}
\langle \Sigma_x \rangle (t) &= \text{Re} \left(e^{-i\omega_\Delta t} \langle \alpha | u_+^\dagger u_- | \alpha \rangle \right) \\
&= \text{Re} \left(e^{-i\omega_\Delta t} e^{-\frac{i(\omega_{e-} - \omega_{e+})t}{2}} \langle \alpha e^{-i\omega_{e+}t} | \alpha e^{-i\omega_{e-}t} \rangle \right) \\
&= \text{Re} \left(e^{-i\omega_\Delta t} e^{-\frac{i(\omega_{e-} - \omega_{e+})t}{2}} \langle \alpha e^{-i\omega_{e+}t} | \alpha e^{-i\omega_{e-}t} \rangle \right),
\end{aligned} \tag{18.609}$$

thus [note that $\langle \rho e^{-i\theta_2} | \rho e^{i\theta_1} \rangle = \exp(-\rho^2(1 - e^{i(\theta_1 - \theta_2)}))$ for $\rho \geq 0$ and $\theta_{1,2} \in \mathcal{R}$]

$$\langle \Sigma_x \rangle (t) = \text{Re} \left(e^{-i\omega_\Delta t} f(\omega_g t) \right), \tag{18.610}$$

where $\omega_g = \omega_{e+} - \omega_{e-}$, and the function $f(\varphi)$ is given by

$$f(\varphi) = e^{\frac{i\varphi}{2}} \exp \left(-|\alpha|^2 (1 - e^{i\varphi}) \right). \tag{18.611}$$

The term $e^{-i\omega_\Delta t}$ gives rise to Rabi oscillation at angular frequency ω_Δ , and the term $f(\omega_g t)$ gives rise to periodic modulation in the Rabi oscillation amplitude having angular frequency ω_g [note that $|f(\varphi)|^2 = e^{-2|\alpha|^2(1 - \cos \varphi)}$]. The reduction of $|f(\omega_g t)|^2$ in time is attributed to the effect of decoherence. Recoherence occurs when $|f(\omega_g t)|^2$ increases in time.

13. The current I_J and voltage V_J of a Josephson junction are related to the phase across the junction Θ by the first $I_J = I_c \sin \Theta$ (18.56) and second $d\Theta/dt = 2eV_J/\hbar$ (18.58) Josephson relations. The current through the capacitor is given by $C_J \dot{V}_J$ and the current through the resistor is given by V_J/R_J , and thus current conservation yields

$$C_J \dot{V}_J + \frac{V_J}{R_J} + I_c \sin \Theta = i_b I_c, \tag{18.612}$$

or in a dimensionless form

$$\beta_C \frac{d^2 \Theta}{d\tau^2} + \frac{d\Theta}{d\tau} + \sin \Theta = i_b, \tag{18.613}$$

where β_C is given by Eq. (18.428) and the dimensionless time τ is related to the time t by

$$\tau = \frac{2\pi c R_J I_c}{\phi_s} t. \tag{18.614}$$

- a) In the overdamped limit Eq. (18.613) becomes (the second derivative term is disregarded)

$$\frac{d\Theta}{d\tau} + \sin \Theta = i_b. \tag{18.615}$$

Below the critical current, i.e. when $|i_b| \leq 1$, a fixed solution given by $\Theta = \sin^{-1} i_b$ exists and consequently $d\Theta/d\tau = 0$, i.e. the voltage vanishes. The case $|i_b| > 1$ is treated by integration of [see Eq. (18.615)]

$$d\tau = \frac{d\Theta}{i_b - \sin \Theta}, \quad (18.616)$$

which leads to

$$\tau = \frac{2}{\sqrt{i_b^2 - 1}} \tan^{-1} \frac{i_b \tan \frac{\Theta}{2} - 1}{\sqrt{i_b^2 - 1}}. \quad (18.617)$$

The inverted relation reads

$$\Theta = 2 \tan^{-1} \frac{1 + \sqrt{i_b^2 - 1} \tan \frac{\pi\tau}{T_J}}{i_b}, \quad (18.618)$$

where the normalized period time T_J is given by

$$T_J = \frac{2\pi}{\sqrt{i_b^2 - 1}}. \quad (18.619)$$

Time averaging of the normalized voltage $d\Theta/d\tau$ (which is periodic in τ) yields

$$\left\langle \frac{d\Theta}{d\tau} \right\rangle = \frac{1}{T_J} \int_0^{T_J} \frac{d\Theta}{d\tau} d\tau = \frac{2\pi}{T_J}, \quad (18.620)$$

and thus [see Eq. (18.619)]

$$V_{dc} = R_J I_c \sqrt{i_b^2 - 1}. \quad (18.621)$$

b) With the help of Eqs. (18.615), (18.618) and (18.619) together with the identity

$$\sin(2 \tan^{-1}(s)) = \frac{2s}{1 + s^2}, \quad (18.622)$$

one finds that

$$\begin{aligned} \frac{d\Theta}{d\tau} &= i_b - \sin \Theta \\ &= i_b - \frac{2 \frac{1 + \sqrt{i_b^2 - 1} \tan \frac{\pi}{2}}{i_b}}{1 + \left(\frac{1 + \sqrt{i_b^2 - 1} \tan \frac{\pi}{2}}{i_b} \right)^2} \\ &= \frac{i_b^2 - 1}{i_b + \frac{\cos x}{i_b} + \frac{\sqrt{i_b^2 - 1} \sin x}{i_b}}, \end{aligned} \quad (18.623)$$

where

$$x = \frac{2\pi\tau}{T_J} . \quad (18.624)$$

With the help of the identity

$$\sin(y) \cos(x) + \cos(y) \sin(x) = \sin(y+x) , \quad (18.625)$$

this can be expressed as

$$\frac{d\Theta}{d\tau} = \mathcal{V} \left(\frac{2\pi\tau}{T_J} + x_0 \right) , \quad (18.626)$$

where the function $\mathcal{V}(x)$ is defined by

$$\mathcal{V}(x) = \frac{i_b^2 - 1}{i_b + \sin x} , \quad (18.627)$$

and where

$$x_0 = \tan^{-1} \frac{1}{\sqrt{i_b^2 - 1}} . \quad (18.628)$$

The Fourier expansion of the function $\mathcal{V}(x)$ is expressed as [see Eq. (18.627)]

$$\mathcal{V}(x) = \sum_{k=-\infty}^{\infty} g_k e^{ikx} . \quad (18.629)$$

With the help of the identity

$$\sin x = \frac{e^{ix} - e^{-ix}}{2i} , \quad (18.630)$$

one obtains

$$\begin{aligned} i_b^2 - 1 &= (i_b + \sin x) \sum_{k=-\infty}^{\infty} g_k e^{ikx} \\ &= \sum_{k=-\infty}^{\infty} \left(i_b g_k + \frac{g_{k-1} - g_{k+1}}{2i} \right) e^{ikx} , \end{aligned} \quad (18.631)$$

or

$$i_b g_k + \frac{1}{2i} (g_{k-1} - g_{k+1}) = \begin{cases} i_b^2 - 1 & \text{if } k = 0 \\ 0 & \text{else} \end{cases} . \quad (18.632)$$

Moreover, $g_{-k} = g_k^*$ since $g(x)$ is real. Seeking a solution having the form

$$g_k = g_0 (iu_b)^k , \quad (18.633)$$

leads to

$$u_b = i_b \pm \sqrt{i_b^2 - 1} . \quad (18.634)$$

To ensure convergence of the Fourier series the solution $i_b - \sqrt{i_b^2 - 1}$ is chosen for $k > 0$ and the solution $i_b - \sqrt{i_b^2 - 1} = \left(i_b + \sqrt{i_b^2 - 1}\right)^{-1}$ is chosen for $k < 0$. For the case $k = 0$ one has

$$i_b g_0 + \frac{1}{2i} (g_{-1} - g_{+1}) = i_b^2 - 1 , \quad (18.635)$$

and thus

$$g_0 = \sqrt{i_b^2 - 1} , \quad (18.636)$$

and therefore

$$g_k = \frac{i_b}{|i_b|} \sqrt{i_b^2 - 1} i^k \left(i_b - \frac{i_b}{|i_b|} \sqrt{i_b^2 - 1}\right)^{|k|} . \quad (18.637)$$

14. Integrating the second Josephson relation (18.58) $d\Theta/dt = 2eV_J/\hbar$

$$\Theta = \frac{2e}{\hbar} \int_0^t dt' V_J(t') , \quad (18.638)$$

and substituting into the first Josephson relation $I_J = I_c \sin \Theta$ (18.56) yield the current

$$I_J = I_c \sin \left(\Theta_0 + \omega_J t + \frac{V_1 \omega_J}{V_0 \omega} \sin(\omega t) \right) , \quad (18.639)$$

where $\Theta_0 = \Theta(t = 0)$ and ω_J , which is given by

$$\omega_J = \frac{2eV_0}{\hbar} , \quad (18.640)$$

is the so-called Josephson frequency. With the help of the Jacobi-Anger expansion (6.417) one obtains

$$I_J = I_c \sum_{n=-\infty}^{\infty} J_n \left(\frac{V_1 \omega_J}{V_0 \omega} \right) \sin(\Theta_0 + (\omega_J + n\omega) t) . \quad (18.641)$$

The total current is given by $I = I_R + I_J$, where $I_R = V(t)/R_J$ is the current through the resistor. The time-averaged value I_n of the current

at the n 'th Shapiro step, where the condition $\omega_J + n\omega = 0$ is satisfied, is thus given by

$$I_n = \frac{V_0}{R_J} + I_c J_n \left(\frac{V_1 \omega_J}{V_0 \omega} \right) \sin(\Theta_0) . \quad (18.642)$$

15. For a transformation having the form $U = \exp(- (i/2) \sigma_z \phi)$, where ϕ is real (which may depend on time), and the Pauli matrix vector $\boldsymbol{\sigma}$ are given by $\boldsymbol{\sigma} = (\sigma_x, \sigma_y, \sigma_z)$ [see (6.137)], the following holds [see Eqs. (6.139) and (6.375), and compare with Eq. (6.176)]

$$\begin{aligned} \hbar^{-1} \mathcal{H}' &= -iU^\dagger \frac{dU}{dt} + \hbar^{-1} U^\dagger \mathcal{H} U \\ &= \begin{pmatrix} \frac{\omega_f - \frac{d\phi}{dt}}{2} & \frac{\omega_\Delta e^{-i(\omega t - \phi)}}{2} \\ \frac{\omega_\Delta e^{i(\omega t - \phi)}}{2} & -\frac{\omega_f - \frac{d\phi}{dt}}{2} \end{pmatrix} . \end{aligned} \quad (18.643)$$

For the case where ϕ is chosen to be given by

$$\phi = -\frac{\omega_{f1}}{\omega_p} \sin(\omega_p t) , \quad (18.644)$$

one obtains [compare with Eq. (6.413), and recall the Jacobi-Anger expansion (6.417)]

$$\begin{aligned} \hbar^{-1} \mathcal{H}' &= \begin{pmatrix} \frac{\omega_{f0}}{2} & \frac{\omega_\Delta e^{-i\left(\omega t - \left(-\frac{\omega_{f1}}{\omega_p} \sin(\omega_p t)\right)\right)}}{2} \\ \frac{\omega_\Delta e^{i\left(\omega t - \left(-\frac{\omega_{f1}}{\omega_p} \sin(\omega_p t)\right)\right)}}{2} & -\frac{\omega_{f0}}{2} \end{pmatrix} \\ &= \begin{pmatrix} \frac{\omega_{f0}}{2} & \frac{\omega_\Delta \sum_{n=-\infty}^{\infty} J_n\left(\frac{\omega_{f1}}{\omega_p}\right) e^{-i(\omega + n\omega_p)t}}{2} \\ \frac{\omega_\Delta \sum_{n=-\infty}^{\infty} J_n\left(\frac{\omega_{f1}}{\omega_p}\right) e^{i(\omega + n\omega_p)t}}{2} & -\frac{\omega_{f0}}{2} \end{pmatrix} . \end{aligned} \quad (18.645)$$

When $\omega + n\omega_p \simeq \omega_{f0}$ the approximation $\mathcal{H}' \simeq \mathcal{H}'_n$ can be employed, where [compare with Eqs. (6.373) and (6.422)]

$$\hbar^{-1} \mathcal{H}'_n = \begin{pmatrix} \frac{\omega_{f0}}{2} & \frac{\omega_\Delta J_n\left(\frac{\omega_{f1}}{\omega_p}\right) e^{-i(\omega + n\omega_p)t}}{2} \\ \frac{\omega_\Delta J_n\left(\frac{\omega_{f1}}{\omega_p}\right) e^{i(\omega + n\omega_p)t}}{2} & -\frac{\omega_{f0}}{2} \end{pmatrix} . \quad (18.646)$$

Note that, the steady state polarization as a function of the qubit damping rates can be evaluated using Eq. (17.300).

16. Since the loop's inductance is negligibly small, the following holds [see Eq. (18.75)]

$$\phi_1 + \phi_2 + \phi_3 = \phi_e , \quad (18.647)$$

where ϕ_n is the phase across the n 'th junction. The Lagrangian of the system $\mathcal{L} = T - U$ [see Eq. (1.16)] can be expressed as a function of the dimensionless flux coordinates Φ_1 and Φ_2 , and their time derivatives $\dot{\Phi}_1$ and $\dot{\Phi}_2$, where

$$\Phi_n = \frac{2\pi\phi_n}{\phi_s}, \quad (18.648)$$

the kinetic energy T is given by

$$T = \frac{C_J\phi_s^2 \left(\dot{\Phi}_1^2 + \dot{\Phi}_2^2 + \alpha (\dot{\Phi}_1 + \dot{\Phi}_2)^2 \right)}{8\pi^2 c^2}, \quad (18.649)$$

and the potential energy U is given by [see Eq. (18.82)]

$$U = -E_J (\cos \Phi_1 + \cos \Phi_2 + \alpha \cos (\Phi_e - \Phi_1 - \Phi_2)), \quad (18.650)$$

where $\Phi_e = 2\pi\phi_e/\phi_s$. The coordinate transformation

$$\Phi_1 = \frac{\frac{\Phi_p}{\sqrt{1+2\alpha}} + \Phi_m}{\sqrt{2}}, \quad (18.651)$$

$$\Phi_2 = \frac{\frac{\Phi_p}{\sqrt{1+2\alpha}} - \Phi_m}{\sqrt{2}}, \quad (18.652)$$

yields

$$T = \frac{C_J\phi_s^2 \left(\dot{\Phi}_p^2 + \dot{\Phi}_m^2 \right)}{8\pi^2 c^2}, \quad (18.653)$$

and [recall that $\cos(x+y) + \cos(x-y) = 2\cos x \cos y$]

$$\frac{U}{E_J} = -u \left(\frac{\Phi_p}{\sqrt{2}\sqrt{1+2\alpha}}, \frac{\Phi_m}{\sqrt{2}} \right), \quad (18.654)$$

where the two-dimensional dimensionless potential u is given by [compare with Eq. (18.86)]

$$u(x_p, x_m) = -2\cos x_p \cos x_m + \alpha \cos(2x_p - \Phi_{e,r}), \quad (18.655)$$

and where $\Phi_e = \pi + \Phi_{e,r}$. Note that the potential $u(x_p, x_m)$ has two wells per unit cell. The wells are symmetric when $\Phi_{e,r} = 0$, i.e. when $\phi_e = \phi_s/2$.

17. The Coulomb interaction $\varphi_{\text{ext}}(\mathbf{r})$ can be expressed as [see Eqs. (16.107) and (16.136)]

$$\varphi_{\text{ext}}(\mathbf{r}) = \frac{e}{|\mathbf{r}|} = \int d^3\mathbf{q} \frac{e}{2\pi^2 q^2} e^{i\mathbf{q}\cdot\mathbf{r}}, \quad (18.656)$$

hence in the Thomas-Fermi approximation [see Eqs. (18.251) and (18.277)]

$$\varphi(\mathbf{q}) = \frac{e}{2\pi^2} \frac{1}{q^2 + k_{\text{TF}}^2}, \quad (18.657)$$

where k_{TF} is given by Eq. (18.276), thus

$$\begin{aligned} \varphi(\mathbf{r}) &= \frac{e}{2\pi^2} \int d^3\mathbf{q} \frac{e^{i\mathbf{q}\cdot\mathbf{r}}}{q^2 + k_{\text{TF}}^2} \\ &= \frac{e}{\pi} \int_0^\infty dq q^2 \int_{-1}^1 d(\cos\theta) \frac{e^{iqr\cos\theta}}{q^2 + k_{\text{TF}}^2} \\ &= \frac{e}{\pi r} \int_0^\infty dq \frac{2q \sin(qr)}{q^2 + k_{\text{TF}}^2} \\ &= \frac{e}{r} e^{-k_{\text{TF}}r}. \end{aligned} \quad (18.658)$$

18. Consider the set of basis states $|\bar{n}\rangle = |\{n_{\mathbf{a},\mathbf{k}}\}, \{n_{\mathbf{c},\mathbf{q}}\}\rangle$, where $n_{\mathbf{a},\mathbf{k}} = \langle \bar{n} | a_{\mathbf{k}}^\dagger a_{\mathbf{k}} | \bar{n} \rangle \in \{0, 1\}$ represents an electron occupation number and $n_{\mathbf{c},\mathbf{q}} = \langle \bar{n} | c_{\mathbf{q}}^\dagger c_{\mathbf{q}} | \bar{n} \rangle \in \{0, 1, 2, \dots\}$ represents a phonon occupation number. The corresponding energy (when electron-phonon interaction is disregarded) is given by [see Eq. (18.434)]

$$E_{\bar{n}} = \sum_{\mathbf{k}} \varepsilon_{\mathbf{a},\mathbf{k}} n_{\mathbf{a},\mathbf{k}} + \sum_{\mathbf{q}} \varepsilon_{\mathbf{c},\mathbf{q}} n_{\mathbf{c},\mathbf{q}}. \quad (18.659)$$

Using this notation Eq. (9.107) reads

$$\begin{aligned} \langle \bar{n}' | \mathcal{H}_{\text{R}} | \bar{n}'' \rangle &= E_{\bar{n}'} \delta_{\bar{n}', \bar{n}''} \\ &+ \frac{1}{2} \sum_{\bar{n}'''} \langle \bar{n}' | V | \bar{n}''' \rangle \langle \bar{n}''' | V | \bar{n}'' \rangle \left(\frac{1}{E_{\bar{n}'} - E_{\bar{n}'''}} - \frac{1}{E_{\bar{n}'''} - E_{\bar{n}''}} \right), \end{aligned} \quad (18.660)$$

where

$$V = i\hbar g \sum_{\mathbf{k}, \mathbf{q}} a_{\mathbf{k}+\mathbf{q}}^\dagger a_{\mathbf{k}} (c_{\mathbf{q}} - c_{-\mathbf{q}}^\dagger). \quad (18.661)$$

When both $|\bar{n}'\rangle$ and $|\bar{n}''\rangle$ represents states with no phonons, i.e. when $n'_{\mathbf{c},\mathbf{q}} = n''_{\mathbf{c},\mathbf{q}} = 0$ for all \mathbf{q} , one has

$$\begin{aligned} \langle \bar{n}' | \mathcal{H}_{\text{R}} | \bar{n}'' \rangle &= E_{\bar{n}'} \delta_{\bar{n}', \bar{n}''} \\ &+ \frac{\hbar^2 g^2}{2} \sum_{\mathbf{k}_1, \mathbf{q}_1, \mathbf{k}_2, \mathbf{q}_2} \sum_{\bar{n}'''} M_{\bar{n}', \bar{n}''}^{(\mathbf{k}_1, \mathbf{q}_1, \mathbf{k}_2, \mathbf{q}_2)} \left(\frac{1}{E_{\bar{n}'} - E_{\bar{n}'''}} - \frac{1}{E_{\bar{n}'''} - E_{\bar{n}''}} \right), \end{aligned} \quad (18.662)$$

where

$$M_{\bar{n}', \bar{n}''}^{(\mathbf{k}_1, \mathbf{q}_1, \mathbf{k}_2, \mathbf{q}_2)} = \langle \bar{n}' | a_{\mathbf{k}_1 + \mathbf{q}_1}^\dagger a_{\mathbf{k}_1} c_{\mathbf{q}_1} | \bar{n}''' \rangle \langle \bar{n}''' | a_{\mathbf{k}_2 + \mathbf{q}_2}^\dagger a_{\mathbf{k}_2} c_{-\mathbf{q}_2}^\dagger | \bar{n}'' \rangle .$$

The term $M_{\bar{n}', \bar{n}''}^{(\mathbf{k}_1, \mathbf{q}_1, \mathbf{k}_2, \mathbf{q}_2)} \neq 0$ only when $\mathbf{q}_1 = -\mathbf{q}_2 \equiv \mathbf{q}$ and $n_{\mathbf{q}'''} = \delta_{\mathbf{q}''', \mathbf{q}}$. Moreover when $M_{\bar{n}', \bar{n}''}^{(\mathbf{k}_1, \mathbf{q}_1, \mathbf{k}_2, \mathbf{q}_2)} \neq 0$ the following holds [see Eq. (18.659)]

$$E_{\bar{n}'} - E_{\bar{n}'''} = \varepsilon_{\mathbf{a}, \mathbf{k}_1 + \mathbf{q}} - \varepsilon_{\mathbf{a}, \mathbf{k}_1} - \varepsilon_{\mathbf{c}, \mathbf{q}} , \quad (18.663)$$

$$E_{\bar{n}'''} - E_{\bar{n}''} = \varepsilon_{\mathbf{a}, \mathbf{k}_2 - \mathbf{q}} - \varepsilon_{\mathbf{a}, \mathbf{k}_2} + \varepsilon_{\mathbf{c}, \mathbf{q}} , \quad (18.664)$$

thus the phonon-mediated electron-electron interaction is represented for this case by an effective Hamiltonian \mathcal{H}_{ee} given by

$$\mathcal{H}_{ee} = \sum_{\mathbf{k}_1, \mathbf{k}_2, \mathbf{q}} v_{\mathbf{k}_1, \mathbf{k}_2, \mathbf{q}} V_{\mathbf{k}_1, \mathbf{k}_2, \mathbf{q}} , \quad (18.665)$$

where

$$V_{\mathbf{k}_1, \mathbf{k}_2, \mathbf{q}} = a_{\mathbf{k}_1 + \mathbf{q}}^\dagger a_{\mathbf{k}_1} a_{\mathbf{k}_2 - \mathbf{q}}^\dagger a_{\mathbf{k}_2} , \quad (18.666)$$

and

$$v_{\mathbf{k}_1, \mathbf{k}_2, \mathbf{q}} = -\frac{\hbar^2 g^2}{2} \left(\frac{1}{\varepsilon_{\mathbf{a}, \mathbf{k}_1} - \varepsilon_{\mathbf{a}, \mathbf{k}_1 + \mathbf{q}} + \varepsilon_{\mathbf{c}, \mathbf{q}}} - \frac{1}{\varepsilon_{\mathbf{a}, \mathbf{k}_2} - \varepsilon_{\mathbf{a}, \mathbf{k}_2 - \mathbf{q}} - \varepsilon_{\mathbf{c}, \mathbf{q}}} \right) . \quad (18.667)$$

The following holds [see Eqs. (16.8) and (16.9)]

$$\begin{aligned} V_{\mathbf{k}_2, \mathbf{k}_1, -\mathbf{q}} &= a_{\mathbf{k}_2 - \mathbf{q}}^\dagger a_{\mathbf{k}_2} a_{\mathbf{k}_1 + \mathbf{q}}^\dagger a_{\mathbf{k}_1} \\ &= a_{\mathbf{k}_2 - \mathbf{q}}^\dagger a_{\mathbf{k}_1} \delta_{\mathbf{k}_2, \mathbf{k}_1 + \mathbf{q}} - a_{\mathbf{k}_1 + \mathbf{q}}^\dagger a_{\mathbf{k}_2} \delta_{\mathbf{k}_2 - \mathbf{q}, \mathbf{k}_1} + a_{\mathbf{k}_1 + \mathbf{q}}^\dagger a_{\mathbf{k}_1} a_{\mathbf{k}_2 - \mathbf{q}}^\dagger a_{\mathbf{k}_2} \\ &= a_{\mathbf{k}_2 - \mathbf{q}}^\dagger a_{\mathbf{k}_1} \delta_{\mathbf{k}_2, \mathbf{k}_1 + \mathbf{q}} - a_{\mathbf{k}_1 + \mathbf{q}}^\dagger a_{\mathbf{k}_2} \delta_{\mathbf{k}_2 - \mathbf{q}, \mathbf{k}_1} + V_{\mathbf{k}_1, \mathbf{k}_2, \mathbf{q}} , \end{aligned} \quad (18.668)$$

and [note that $\varepsilon_{\mathbf{c}, -\mathbf{q}} = \varepsilon_{\mathbf{c}, \mathbf{q}}$ and $1/(x+y) - 1/(x-y) = -2y/(x^2 - y^2)$]

$$\begin{aligned} \tilde{v}_{\mathbf{k}_1, \mathbf{k}_2, \mathbf{q}} &\equiv \frac{v_{\mathbf{k}_1, \mathbf{k}_2, \mathbf{q}} + v_{\mathbf{k}_2, \mathbf{k}_1, -\mathbf{q}}}{2} \\ &= \frac{\hbar^2 g^2 \varepsilon_{\mathbf{c}, \mathbf{q}}}{2} \left(\frac{1}{(\varepsilon_{\mathbf{a}, \mathbf{k}_1} - \varepsilon_{\mathbf{a}, \mathbf{k}_1 + \mathbf{q}})^2 - \varepsilon_{\mathbf{c}, \mathbf{q}}^2} + \frac{1}{(\varepsilon_{\mathbf{a}, \mathbf{k}_2} - \varepsilon_{\mathbf{a}, \mathbf{k}_2 - \mathbf{q}})^2 - \varepsilon_{\mathbf{c}, \mathbf{q}}^2} \right) , \end{aligned} \quad (18.669)$$

thus, using the relation [see Eq. (18.665)]

$$\mathcal{H}_{ee} = \frac{1}{2} \sum_{\mathbf{k}_1, \mathbf{k}_2, \mathbf{q}} v_{\mathbf{k}_1, \mathbf{k}_2, \mathbf{q}} V_{\mathbf{k}_1, \mathbf{k}_2, \mathbf{q}} + \frac{1}{2} \sum_{\mathbf{k}_1, \mathbf{k}_2, \mathbf{q}} v_{\mathbf{k}_2, \mathbf{k}_1, -\mathbf{q}} V_{\mathbf{k}_2, \mathbf{k}_1, -\mathbf{q}} , \quad (18.670)$$

one finds that the Hamiltonian \mathcal{H}_{ee} can be expressed as (the single-electron terms proportional to $a_{\mathbf{k}_2-\mathbf{q}}^\dagger a_{\mathbf{k}_1}$ and $a_{\mathbf{k}_1+\mathbf{q}}^\dagger a_{\mathbf{k}_2}$ are disregarded)

$$\mathcal{H}_{ee} = \sum_{\mathbf{k}_1, \mathbf{k}_2, \mathbf{q}} \tilde{v}_{\mathbf{k}_1, \mathbf{k}_2, \mathbf{q}} a_{\mathbf{k}_1+\mathbf{q}}^\dagger a_{\mathbf{k}_1} a_{\mathbf{k}_2-\mathbf{q}}^\dagger a_{\mathbf{k}_2} . \quad (18.671)$$

In the region where $|\varepsilon_{a, \mathbf{k}_1, 2} - \varepsilon_{a, \mathbf{k}_1, 2+\mathbf{q}}| < \varepsilon_{c, \mathbf{q}}$ the phonon-mediated interaction becomes attractive.

19. The following holds [see Eqs. (18.327) and (18.328)]

$$\langle \Psi_0 | a_{\mathbf{k}', \sigma}^\dagger a_{\mathbf{k}', \sigma} | \Psi_0 \rangle = \sin^2 \theta_{\mathbf{k}'}, \quad (18.672)$$

thus

$$\langle \Psi_0 | n_{\mathbf{P}} | \Psi_0 \rangle = \sum_{\mathbf{k}'} \sin^2 \theta_{\mathbf{k}'}. \quad (18.673)$$

Similarly, since $(a_{\mathbf{k}', \sigma}^\dagger a_{\mathbf{k}', \sigma})^2 = a_{\mathbf{k}', \sigma}^\dagger a_{\mathbf{k}', \sigma} a_{\mathbf{k}', \sigma} a_{\mathbf{k}', \sigma}$ one finds that

$$\begin{aligned} \langle \Psi_0 | n_{\mathbf{P}}^2 | \Psi_0 \rangle &= \frac{1}{4} \sum_{\mathbf{k}', \mathbf{k}''} \langle \Psi_0 | (a_{\mathbf{k}', \uparrow}^\dagger a_{\mathbf{k}', \uparrow} + a_{-\mathbf{k}', \downarrow}^\dagger a_{-\mathbf{k}', \downarrow}) (a_{\mathbf{k}'', \uparrow}^\dagger a_{\mathbf{k}'', \uparrow} + a_{-\mathbf{k}'', \downarrow}^\dagger a_{-\mathbf{k}'', \downarrow}) | \Psi_0 \rangle \\ &= \frac{1}{4} \sum_{\mathbf{k}'} \langle \Psi_0 | a_{\mathbf{k}', \uparrow}^\dagger a_{\mathbf{k}', \uparrow} + a_{-\mathbf{k}', \downarrow}^\dagger a_{-\mathbf{k}', \downarrow} + 2a_{\mathbf{k}', \uparrow}^\dagger a_{\mathbf{k}', \uparrow} a_{-\mathbf{k}', \downarrow}^\dagger a_{-\mathbf{k}', \downarrow} | \Psi_0 \rangle \\ &\quad + \frac{1}{4} \sum_{\mathbf{k}' \neq \mathbf{k}''} \langle \Psi_0 | (a_{\mathbf{k}', \uparrow}^\dagger a_{\mathbf{k}', \uparrow} + a_{-\mathbf{k}', \downarrow}^\dagger a_{-\mathbf{k}', \downarrow}) (a_{\mathbf{k}'', \uparrow}^\dagger a_{\mathbf{k}'', \uparrow} + a_{-\mathbf{k}'', \downarrow}^\dagger a_{-\mathbf{k}'', \downarrow}) | \Psi_0 \rangle \\ &= \frac{1}{2} \sum_{\mathbf{k}'} \sin^2 \theta_{\mathbf{k}'} + \sin^4 \theta_{\mathbf{k}'} + \sum_{\mathbf{k}' \neq \mathbf{k}''} \sin^2 \theta_{\mathbf{k}'} \sin^2 \theta_{\mathbf{k}''}, \end{aligned} \quad (18.674)$$

thus

$$\begin{aligned} \langle \Psi_0 | (\Delta n_{\mathbf{P}})^2 | \Psi_0 \rangle &= \langle \Psi_0 | n_{\mathbf{P}}^2 | \Psi_0 \rangle - (\langle \Psi_0 | n_{\mathbf{P}} | \Psi_0 \rangle)^2 \\ &= \frac{1}{2} \sum_{\mathbf{k}'} \sin^2 \theta_{\mathbf{k}'} + \sin^4 \theta_{\mathbf{k}'} + \sum_{\mathbf{k}' \neq \mathbf{k}''} \sin^2 \theta_{\mathbf{k}'} \sin^2 \theta_{\mathbf{k}''} - \sum_{\mathbf{k}', \mathbf{k}''} \sin^2 \theta_{\mathbf{k}'} \sin^2 \theta_{\mathbf{k}''} \\ &= \frac{1}{2} \sum_{\mathbf{k}'} \sin^2 \theta_{\mathbf{k}'} (1 - \sin^2 \theta_{\mathbf{k}'}) \\ &= \frac{1}{2} \sum_{\mathbf{k}'} \sin^2 \theta_{\mathbf{k}'} \cos^2 \theta_{\mathbf{k}'}. \end{aligned}$$

20. With the help of Eqs. (16.103) and (18.311) one finds that the density of states $D(\epsilon)$ per unit volume (volume is labeled by \mathcal{V}) is given by [compare with Eq. (16.104)]

$$\begin{aligned}
 D(\epsilon) &= \frac{1}{\mathcal{V}} \sum_{\mathbf{k}'} \delta(\epsilon - \eta_{\mathbf{k}'}) \\
 &= \frac{1}{\mathcal{V}} \frac{2\mathcal{V}}{8\pi^3} 4\pi \int_0^\infty dk' k'^2 \delta\left(\epsilon - \sqrt{(\epsilon_{k'} - \epsilon_F)^2 + |\Delta|^2}\right).
 \end{aligned} \tag{18.675}$$

Assuming that the energy $\epsilon_{k'}$ of an electron having wave vector \mathbf{k}' is given by [see Eq. (16.98)]

$$\epsilon_{k'} = \frac{\hbar^2 k'^2}{2m}, \tag{18.676}$$

one finds that

$$\begin{aligned}
 D(\epsilon) &= D_F \int_0^\infty d\epsilon' \sqrt{\frac{\epsilon'}{\epsilon_F}} \delta\left(\epsilon - \sqrt{(\epsilon' - \epsilon_F)^2 + |\Delta|^2}\right) \\
 &= D_F \left(1 + \frac{\sqrt{\epsilon^2 - |\Delta|^2}}{\epsilon_F}\right)^{1/2} \frac{\epsilon}{\sqrt{\epsilon^2 - |\Delta|^2}},
 \end{aligned} \tag{18.677}$$

where

$$D_F = \frac{2^{1/2} m^{3/2}}{\pi^2 \hbar^3} \sqrt{\epsilon_F} \tag{18.678}$$

is the normal phase density of states per unit volume at the Fermi energy, which is labeled by ϵ_F . For the case where $\epsilon \ll \epsilon_F$ and $|\Delta| \ll \epsilon_F$ one has

$$D(\epsilon) = D_F \frac{\epsilon}{\sqrt{\epsilon^2 - |\Delta|^2}}. \tag{18.679}$$

21. The time evolution of the operators $b_{\mathbf{k},\uparrow}(t)$ and $b_{-\mathbf{k},\downarrow}^\dagger(t)$ is governed by [see Eqs. (4.37) and (18.318)]

$$\frac{db_{\mathbf{k},\uparrow}}{dt} = -i\hbar^{-1} \sum_{\mathbf{k}',\sigma} \eta_{\mathbf{k}'} \left[b_{\mathbf{k},\uparrow}, b_{\mathbf{k}',\sigma}^\dagger b_{\mathbf{k}',\sigma} \right], \tag{18.680}$$

$$\frac{db_{-\mathbf{k},\downarrow}^\dagger}{dt} = -i\hbar^{-1} \sum_{\mathbf{k}',\sigma} \eta_{\mathbf{k}'} \left[b_{-\mathbf{k},\downarrow}^\dagger, b_{\mathbf{k}',\sigma}^\dagger b_{\mathbf{k}',\sigma} \right], \tag{18.681}$$

thus

$$\frac{db_{\mathbf{k},\uparrow}}{dt} = -i\hbar^{-1} \eta_{\mathbf{k}} \left[b_{\mathbf{k},\uparrow}, b_{\mathbf{k},\uparrow}^\dagger b_{\mathbf{k},\uparrow} \right], \tag{18.682}$$

$$\frac{db_{-\mathbf{k},\downarrow}^\dagger}{dt} = -i\hbar^{-1} \eta_{-\mathbf{k}} \left[b_{-\mathbf{k},\downarrow}^\dagger, b_{-\mathbf{k},\downarrow}^\dagger b_{-\mathbf{k},\downarrow} \right]. \tag{18.683}$$

With the help of the identity (16.70) one finds that

$$\frac{db_{\mathbf{k},\uparrow}}{dt} = -i\hbar^{-1}\eta_{\mathbf{k}}b_{\mathbf{k},\uparrow}, \quad (18.684)$$

$$\frac{db_{-\mathbf{k},\downarrow}^\dagger}{dt} = i\hbar^{-1}\eta_{-\mathbf{k}}b_{-\mathbf{k},\downarrow}^\dagger, \quad (18.685)$$

thus

$$\begin{pmatrix} b_{\mathbf{k},\uparrow}(t) \\ b_{-\mathbf{k},\downarrow}^\dagger(t) \end{pmatrix} = \begin{pmatrix} e^{-i\hbar^{-1}\eta_{\mathbf{k}}t} & 0 \\ 0 & e^{i\hbar^{-1}\eta_{\mathbf{k}}t} \end{pmatrix} \begin{pmatrix} b_{\mathbf{k},\uparrow}(0) \\ b_{-\mathbf{k},\downarrow}^\dagger(0) \end{pmatrix}. \quad (18.686)$$

The transformation (18.317), according to which

$$\begin{pmatrix} a_{\mathbf{k},\uparrow} \\ a_{-\mathbf{k},\downarrow}^\dagger \end{pmatrix} = M_{\text{B}} \begin{pmatrix} b_{\mathbf{k},\uparrow} \\ b_{-\mathbf{k},\downarrow}^\dagger \end{pmatrix}, \quad (18.687)$$

where

$$M_{\text{B}} = \begin{pmatrix} e^{-i\phi_{\Delta}} \cos \theta_{\mathbf{k}} & -e^{-i\phi_{\Delta}} \sin \theta_{\mathbf{k}} \\ e^{i\phi_{\Delta}} \sin \theta_{\mathbf{k}} & e^{i\phi_{\Delta}} \cos \theta_{\mathbf{k}} \end{pmatrix}, \quad (18.688)$$

leads to

$$\begin{pmatrix} a_{\mathbf{k},\uparrow}(t) \\ a_{-\mathbf{k},\downarrow}^\dagger(t) \end{pmatrix} = M_{\text{B}} \begin{pmatrix} e^{-i\hbar^{-1}\eta_{\mathbf{k}}t} & 0 \\ 0 & e^{i\hbar^{-1}\eta_{\mathbf{k}}t} \end{pmatrix} M_{\text{B}}^{-1} \begin{pmatrix} a_{\mathbf{k},\uparrow}(0) \\ a_{-\mathbf{k},\downarrow}^\dagger(0) \end{pmatrix}, \quad (18.689)$$

thus [see Eqs. (18.330), (18.331) and (18.311)]

$$\begin{aligned} & \begin{pmatrix} a_{\mathbf{k},\uparrow}(t) \\ a_{-\mathbf{k},\downarrow}^\dagger(t) \end{pmatrix} \\ &= \begin{pmatrix} \cos \frac{\eta_{\mathbf{k}}t}{\hbar} - i \frac{\epsilon_{\mathbf{k}'} - \epsilon_{\text{F}}}{\eta_{\mathbf{k}'}} \sin \frac{\eta_{\mathbf{k}}t}{\hbar} & i \frac{|\Delta|}{\eta_{\mathbf{k}'}} e^{-2i\phi_{\Delta}} \sin \frac{\eta_{\mathbf{k}}t}{\hbar} \\ i \frac{|\Delta|}{\eta_{\mathbf{k}'}} e^{2i\phi_{\Delta}} \sin \frac{\eta_{\mathbf{k}}t}{\hbar} & \cos \frac{\eta_{\mathbf{k}}t}{\hbar} + i \frac{\epsilon_{\mathbf{k}'} - \epsilon_{\text{F}}}{\eta_{\mathbf{k}'}} \sin \frac{\eta_{\mathbf{k}}t}{\hbar} \end{pmatrix} \begin{pmatrix} a_{\mathbf{k},\uparrow}(0) \\ a_{-\mathbf{k},\downarrow}^\dagger(0) \end{pmatrix}. \end{aligned} \quad (18.690)$$

22. The entropy σ_{S} is given by [see Eq. (16.287)]

$$\sigma_{\text{S}} = - \sum_{\mathbf{k}',\sigma} [n_{\mathbf{k}',\sigma} \log n_{\mathbf{k}',\sigma} + (1 - n_{\mathbf{k}',\sigma}) \log (1 - n_{\mathbf{k}',\sigma})], \quad (18.691)$$

where $n_{\mathbf{k}',\sigma} = 1 / (e^{\beta\eta_{\mathbf{k}'}} + 1)$ [see Eq. (18.335)], $\beta = 1 / (k_{\text{B}}T)$, and $\eta_{\mathbf{k}'} = \sqrt{(\epsilon_{\mathbf{k}'} - \epsilon_{\text{F}})^2 + |\Delta|^2}$ [see Eq. (18.311)], with \mathbf{k}' denoting wave vector and σ denoting spin state. In the low temperature limit $n_{\mathbf{k}',\sigma} \simeq e^{-\beta\eta_{\mathbf{k}'}} \ll 1$, hence

$$\sigma_{\text{S}} = \sum_{\mathbf{k}',\sigma} \beta\eta_{\mathbf{k}'} e^{-\beta\eta_{\mathbf{k}'}} , \quad (18.692)$$

or

$$\begin{aligned}
 \sigma_S &= \mathcal{V} D_F \beta \int_{\Delta_0}^{\infty} d\eta \frac{d\epsilon}{d\eta} \sqrt{\frac{\epsilon}{\epsilon_F}} \eta e^{-\beta\eta} \\
 &\simeq \mathcal{V} D_F \beta \Delta_0^2 \int_{\Delta_0}^{\infty} d\eta \frac{e^{-\beta\eta}}{\sqrt{\eta^2 - \Delta_0^2}} \\
 &\simeq \frac{\mathcal{V} D_F \beta \Delta_0^2}{\sqrt{2\Delta_0}} \int_{\Delta_0}^{\infty} d\eta \frac{e^{-\beta\eta}}{\sqrt{\eta - \Delta_0}} \\
 &= \sqrt{\frac{\pi}{2}} \mathcal{V} D_F \Delta_0 \sqrt{\beta \Delta_0} e^{-\beta \Delta_0} ,
 \end{aligned} \tag{18.693}$$

where \mathcal{V} is the volume, and $D_F = 2^{1/2} m^{3/2} \sqrt{\epsilon_F} / (\pi^2 \hbar^3)$ is the energy density of states per unit volume at the Fermi energy ϵ_F [see Eq. (16.104)]. In terms of the entropy of a free electron gas σ_N , which is given by Eq. (16.291), σ_S is given by

$$\sigma_S = \frac{3\sigma_N}{\sqrt{2}\pi^{3/2}} (\beta \Delta_0)^{3/2} e^{-\beta \Delta_0} , \tag{18.694}$$

hence $\sigma_S \ll \sigma_N$ in the low temperature limit.

23. With the help of Eq. (18.693), which states that $\sigma_S = \sqrt{\pi/2} \mathcal{V} D_F \Delta_0 \sqrt{\beta \Delta_0} e^{-\beta \Delta_0}$, where \mathcal{V} is the volume, $\beta = 1/(k_B T)$, k_B is the Boltzmann's constant, and $D_F = 2^{1/2} m^{3/2} \sqrt{\epsilon_F} / (\pi^2 \hbar^3)$ is the energy density of states per unit volume at the Fermi energy ϵ_F , one finds that

$$\begin{aligned}
 C_S &= T \frac{d\sigma_S}{dT} \\
 &= -\frac{1}{k_B T} \frac{d\sigma_S}{d\beta} \\
 &= -\sqrt{\pi/2} \mathcal{V} D_F \beta \Delta_0^2 \left(\frac{1}{2\sqrt{\beta \Delta_0}} - \sqrt{\beta \Delta_0} \right) e^{-\beta \Delta_0} ,
 \end{aligned} \tag{18.695}$$

thus [recall that in the derivation of Eq. (18.693) it was assumed that $\beta \Delta_0 \gg 1$]

$$C_S = \sqrt{\pi/2} \mathcal{V} D_F \Delta_0 (\beta \Delta_0)^{3/2} e^{-\beta \Delta_0} . \tag{18.696}$$

For comparison, for the case of a free electron gas, to lowest non-vanishing order in T [see Eq. (16.291)]

$$C_N = -\frac{1}{k_B T} \frac{d\sigma_N}{d\beta} = \frac{\pi^2 \mathcal{V} D_F}{3\beta} . \tag{18.697}$$

24. By using Eqs. (18.329) and (18.330) one finds that at zero temperature

$$\begin{aligned}\langle B_{\mathbf{k}'}^\dagger \rangle &= -\frac{e^{2i\phi_\Delta} \sin(2\theta_{\mathbf{k}'})}{2} \\ &= \frac{1}{2} \frac{e^{2i\phi_\Delta} |\Delta|}{\sqrt{(\epsilon_{\mathbf{k}'} - \epsilon_F)^2 + |\Delta|^2}},\end{aligned}\tag{18.698}$$

hence [see Eqs. (18.311) and (18.438)]

$$\mathcal{H}_{\text{MF,C}} = \sum_{\mathbf{k}'} \left(|\epsilon_{\mathbf{k}'} - \epsilon_F| - \sqrt{(\epsilon_{\mathbf{k}'} - \epsilon_F)^2 + |\Delta|^2} + \frac{|\Delta|^2}{2\sqrt{(\epsilon_{\mathbf{k}'} - \epsilon_F)^2 + |\Delta|^2}} \right),\tag{18.699}$$

or [see Eq. (14.74)]

$$\begin{aligned}\mathcal{H}_{\text{MF,C}} &= 2\mathcal{V}D_F \int_{\epsilon_F}^{\infty} d\epsilon \sqrt{\frac{\epsilon}{\epsilon_F}} \left(\epsilon - \epsilon_F - \sqrt{(\epsilon - \epsilon_F)^2 + |\Delta|^2} + \frac{|\Delta|^2}{2\sqrt{(\epsilon - \epsilon_F)^2 + |\Delta|^2}} \right) \\ &= 2\mathcal{V}D_F |\Delta|^2 \int_0^{\infty} dx \sqrt{1 + \frac{|\Delta|x}{\epsilon_F}} \left(x - \sqrt{1 + x^2} + \frac{1}{2\sqrt{1 + x^2}} \right) \\ &= 2\mathcal{V}D_F |\Delta|^2 \int_0^{\infty} dx \left(x - \sqrt{1 + x^2} + \frac{1}{2\sqrt{1 + x^2}} \right) + O\left(\left(\frac{|\Delta|}{\epsilon_F}\right)^3\right) \\ &= 2\mathcal{V}D_F |\Delta|^2 \left(-\frac{1}{4} \right) + O\left(\left(\frac{|\Delta|}{\epsilon_F}\right)^3\right),\end{aligned}\tag{18.700}$$

where \mathcal{V} is the volume, and $D_F = 2^{1/2}m^{3/2}\sqrt{\epsilon_F}/(\pi^2\hbar^3)$ is the energy density of states per unit volume at the Fermi energy ϵ_F [see Eq. (16.104)], hence to second order in $|\Delta|/\epsilon_F$ [see Eq. (18.436)]

$$B_C = \sqrt{4\pi D_F |\Delta|^2}.\tag{18.701}$$

25. The 2×2 matrix representation of the single-spin operators $\sigma_\pm = (\sigma_x \pm i\sigma_y)/2$ and $N = \sigma_- \sigma_+$ are given by [see Eq. (6.137)]

$$\sigma_+ \doteq \begin{pmatrix} 0 & 1 \\ 0 & 0 \end{pmatrix},\tag{18.702}$$

$$\sigma_- \doteq \begin{pmatrix} 0 & 0 \\ 1 & 0 \end{pmatrix},\tag{18.703}$$

and

$$N \doteq \begin{pmatrix} 0 & 0 \\ 0 & 1 \end{pmatrix}, \quad (18.704)$$

and thus (note that $N^n = N$ for any positive integer n , and that $e^{i\pi} = -1$)

$$e^{i\pi N} \doteq \begin{pmatrix} 1 & 0 \\ 0 & -1 \end{pmatrix}. \quad (18.705)$$

Note that

$$\sigma_+ \sigma_- + \sigma_- \sigma_+ \doteq \begin{pmatrix} 1 & 0 \\ 0 & 1 \end{pmatrix}, \quad (18.706)$$

$$\sigma_+ \sigma_- - \sigma_- \sigma_+ \doteq \begin{pmatrix} 1 & 0 \\ 0 & -1 \end{pmatrix}, \quad (18.707)$$

and

$$\sigma_+^2 = \sigma_-^2 \doteq \begin{pmatrix} 0 & 0 \\ 0 & 0 \end{pmatrix}. \quad (18.708)$$

The Hilbert space of the L spin system can be spanned by the set of 2^L ket vectors $\{|\eta_1, \eta_2, \dots, \eta_L\rangle\}$, which satisfy

$$\sigma_{l,z} |\eta_1, \eta_2, \dots, \eta_L\rangle = \eta_l |\eta_1, \eta_2, \dots, \eta_L\rangle, \quad (18.709)$$

and where $\eta_l \in \{-1, 1\}$.

a) As can be see from Eqs. (18.441) and (18.709), the following holds

$$Q_l |\eta_1, \eta_2, \dots, \eta_L\rangle = \left(\prod_{l'=1}^{l-1} \eta_{l'} \right) |\eta_1, \eta_2, \dots, \eta_L\rangle, \quad (18.710)$$

and thus the relations (18.443) and (18.444) hold. Note that [see Eqs.(18.439), (18.443) and (18.710)]

$$a_l = Q_l \sigma_{l,+} = \sigma_{l,+} Q_l. \quad (18.711)$$

b) The following holds [see Eqs. (18.439), (18.443) and (18.444)]

$$[a_{l'}, a_{l''}]_+ = Q_{l'} \sigma_{l',+} Q_{l''} \sigma_{l'',+} + Q_{l''} \sigma_{l'',+} Q_{l'} \sigma_{l',+}, \quad (18.712)$$

$$[a_{l'}^\dagger, a_{l''}^\dagger]_+ = \sigma_{l',-} Q_{l'} \sigma_{l'',-} Q_{l''} + \sigma_{l'',-} Q_{l''} \sigma_{l',-} Q_{l'}, \quad (18.713)$$

$$[a_{l'}, a_{l''}^\dagger]_+ = Q_{l'} \sigma_{l',+} \sigma_{l'',-} Q_{l''} + \sigma_{l'',-} Q_{l''} Q_{l'} \sigma_{l',+}, \quad (18.714)$$

By considering all three possibilities $l' < l''$, $l' = l''$ and $l' > l''$, one concludes, using the above relations together with Eqs. (18.706) and

(18.710), that Eqs. (18.445) and (18.446) hold. As an example, for the case $l' < l''$, one has

$$\begin{aligned}
 & [a_{l'}, a_{l'']_+ |\eta_1, \eta_2, \dots, \eta_{l'}, \dots, \eta_{l''}, \dots, \eta_L\rangle \\
 &= Q_{l'} \sigma_{l',+} Q_{l''} \sigma_{l'',+} |\eta_1, \eta_2, \dots, \eta_{l'}, \dots, \eta_{l''}, \dots, \eta_L\rangle \\
 &+ Q_{l''} \sigma_{l'',+} Q_{l'} \sigma_{l',+} |\eta_1, \eta_2, \dots, \eta_{l'}, \dots, \eta_{l''}, \dots, \eta_L\rangle \\
 &= \delta_{\eta_{l'}, -1} \delta_{\eta_{l''}, -1} \left(\prod_{l''=l'+1}^{l''-1} \eta_{l''} \right) (-1+1) |\eta_1, \eta_2, \dots, -\eta_{l'}, \dots, -\eta_{l''}, \dots, \eta_L\rangle \\
 &= 0.
 \end{aligned} \tag{18.715}$$

- c) Using the relation [see Eqs. (18.439), (18.442), (18.708), (18.443), (18.444) and (18.711)]

$$\left(a_l^\dagger + a_l \right) \left(a_l^\dagger - a_l \right) = (\sigma_{l,-} + \sigma_{l,+}) (\sigma_{l,-} - \sigma_{l,+}) , \tag{18.716}$$

one finds that Eq. (18.447) holds [see Eq. (18.707)]. With the help of Eqs. (18.445), (18.446), (18.447) and (18.711) one finds that (note that $Q_l Q_{l+1} = 1 - 2N_l$)

$$\begin{aligned}
 \sigma_{l,x} \sigma_{l+1,x} &= (\sigma_{l,+} + \sigma_{l,-}) (\sigma_{l+1,+} + \sigma_{l+1,-}) \\
 &= \left(a_l + a_l^\dagger \right) Q_l Q_{l+1} \left(a_{l+1} + a_{l+1}^\dagger \right) \\
 &= \left(a_l + a_l^\dagger \right) \left(a_l^\dagger + a_l \right) \left(a_l^\dagger - a_l \right) \left(a_{l+1} + a_{l+1}^\dagger \right) \\
 &= \left(a_l^\dagger - a_l \right) \left(a_{l+1}^\dagger + a_{l+1} \right) ,
 \end{aligned} \tag{18.717}$$

and

$$\begin{aligned}
 \sigma_{l,y} \sigma_{l+1,y} &= -(\sigma_{l,+} - \sigma_{l,-}) (\sigma_{l+1,+} - \sigma_{l+1,-}) \\
 &= -\left(a_l - a_l^\dagger \right) Q_l Q_{l+1} \left(a_{l+1} - a_{l+1}^\dagger \right) \\
 &= -\left(a_l - a_l^\dagger \right) \left(a_l^\dagger + a_l \right) \left(a_l^\dagger - a_l \right) \left(a_{l+1} - a_{l+1}^\dagger \right) \\
 &= -\left(a_l^\dagger + a_l \right) \left(a_{l+1}^\dagger - a_{l+1} \right) ,
 \end{aligned} \tag{18.718}$$

thus Eqs. (18.448) and (18.449) hold.

- d) The last ($l = L$) coupling term $\sigma_{L,x} \sigma_{1,x}$ can be expressed as [see Eqs. (16.11), (18.716) and (18.717)]

$$\begin{aligned}
 \sigma_{L,x}\sigma_{1,x} &= (\sigma_{L,+} + \sigma_{L,-})(\sigma_{1,+} + \sigma_{1,-}) \\
 &= Q_L (a_L + a_L^\dagger) (a_1 + a_1^\dagger) \\
 &= e^{i\pi \sum_{l=1}^{L-1} N_l} (a_L + a_L^\dagger) (a_1 + a_1^\dagger) \\
 &= e^{i\pi N} e^{-i\pi N_L} (a_L + a_L^\dagger) (a_1 + a_1^\dagger) \\
 &= e^{i\pi N} (a_L^\dagger + a_L) (a_L^\dagger - a_L) (a_L + a_L^\dagger) (a_1 + a_1^\dagger) \\
 &= -e^{i\pi N} (a_L^\dagger - a_L) (a_1^\dagger + a_1) ,
 \end{aligned} \tag{18.719}$$

where

$$N = \sum_{l=1}^L N_l . \tag{18.720}$$

The above result together with Eqs. (18.447) and (18.448) lead to Eq. (18.451).

e) The following holds [see Eqs. (18.450) and (18.705)]

$$\begin{aligned}
 [e^{i\pi N}, \mathcal{H}] &= -\Omega \sum_{l''=1}^L \left[\prod_{l'=1}^L \sigma_{l',z}, \sigma_{l'',z} \right] - J \sum_{l''=1}^L \left[\prod_{l'=1}^L \sigma_{l',z}, \sigma_{l'',x} \sigma_{l''+1,x} \right] \\
 &= -J \sum_{l''=1}^L \left[\prod_{l'=1}^L \sigma_{l',z}, \sigma_{l'',x} \sigma_{l''+1,x} \right] \\
 &= -J \sum_{l''=1}^L \left(\prod_{l'=1}^{l''-1} \sigma_{l',z} \right) [\sigma_{l'',z} \sigma_{l''+1,z}, \sigma_{l'',x} \sigma_{l''+1,x}] \left(\prod_{l'=l''+2}^L \sigma_{l',z} \right) ,
 \end{aligned} \tag{18.721}$$

where

$$\begin{aligned}
 &[\sigma_{l'',z} \sigma_{l''+1,z}, \sigma_{l'',x} \sigma_{l''+1,x}] \\
 &= \sigma_{l'',z} \sigma_{l''+1,x} [\sigma_{l''+1,z}, \sigma_{l''+1,x}] + [\sigma_{l'',z}, \sigma_{l''+1,x}] \sigma_{l''+1,x} \sigma_{l''+1,z} \\
 &= i\sigma_{l'',y} (2i) \sigma_{l''+1,y} + (2i) \sigma_{l'',y} (-i) \sigma_{l''+1,y} \\
 &= 0 ,
 \end{aligned} \tag{18.722}$$

thus Eq. (18.453) holds.

f) The commutation relations (18.456) and (18.457) are obtained using the commutation relations (18.445) and (18.446), together with the identity (for $n'' \neq n'$)

$$\frac{1}{L} \sum_{l'=1}^L e^{\frac{2\pi i(n''-n')l'}{L}} = \frac{e^{\frac{2\pi i(n''-n')}{L}}}{L} \frac{1 - e^{2\pi i(n''-n')}}{1 - e^{\frac{2\pi i(n''-n')}{L}}}, \quad (18.723)$$

which for the case where $n''-n'$ is an integer [see Eq. (18.455)] implies that

$$\frac{1}{L} \sum_{l'=1}^L e^{\frac{2\pi i(n''-n')l'}{L}} = \delta_{n',n''}. \quad (18.724)$$

g) Note that the transformation inverse to (18.454) is given by [see Eqs. (18.455) and (18.724)]

$$a_l = \frac{e^{i\varphi}}{\sqrt{L}} \sum_{n \in \mathcal{N}(n_0)} e^{\frac{2\pi i n l}{L}} A_n. \quad (18.725)$$

The inverse transformation (18.725) implies that

$$a_{l+L} = \frac{e^{i\varphi}}{\sqrt{L}} \sum_{n \in \mathcal{N}(n_0)} e^{\frac{2\pi i n l}{L}} e^{2\pi i n} A_n. \quad (18.726)$$

To achieve consistency between the above result (18.726) and Eq. (18.459), the constant n_0 [see Eq. (18.455)] is chosen to be given by

$$n_0 = \begin{cases} \frac{1}{2} & \text{for } \langle e^{i\pi N} \rangle = +1 \\ 0 & \text{for } \langle e^{i\pi N} \rangle = -1 \end{cases}. \quad (18.727)$$

The following holds [see Eqs. (18.724) and (18.725)]

$$\begin{aligned} \sum_{l=1}^L N_l &= \sum_{n',n'' \in \mathcal{N}(n_0)} A_{n''}^\dagger A_{n'} \frac{1}{L} \sum_{l=1}^L e^{\frac{2\pi i(n'-n'')l}{L}} \\ &= \sum_{n \in \mathcal{N}(n_0)} A_n^\dagger A_n \\ &= \sum_{n \in \mathcal{N}(n_0)} \frac{A_n^\dagger A_n + A_{-n}^\dagger A_{-n}}{2} \\ &= \sum_{n \in \mathcal{N}(n_0)} \frac{1 + A_n^\dagger A_n - A_{-n} A_{-n}^\dagger}{2}, \end{aligned} \quad (18.728)$$

$$(18.729)$$

$$\begin{aligned}
 \sum_{l=1}^L a_l^\dagger a_{l+1}^\dagger &= e^{-2i\varphi} \sum_{n', n'' \in \mathcal{N}(n_0)} A_{n''}^\dagger A_{n'}^\dagger \frac{e^{-\frac{2\pi i n'}{L}}}{L} \sum_{l=1}^L e^{\frac{2\pi i(-n'-n'')l}{L}} \\
 &= e^{-2i\varphi} \sum_{n \in \mathcal{N}(n_0)} A_{-n}^\dagger A_n^\dagger e^{-\frac{2\pi i n}{L}} \\
 &= -i e^{-2i\varphi} \sum_{n \in \mathcal{N}(n_0)} A_{-n}^\dagger A_n^\dagger \sin \frac{2\pi n}{L},
 \end{aligned} \tag{18.730}$$

$$\begin{aligned}
 \sum_{l=1}^L a_l^\dagger a_{l+1} &= \sum_{n', n'' \in \mathcal{N}(n_0)} A_{n''}^\dagger A_{n'} \frac{e^{\frac{2\pi i n'}{L}}}{L} \sum_{l=1}^L e^{\frac{2\pi i(n'-n'')l}{L}} \\
 &= \sum_{n \in \mathcal{N}(n_0)} A_n^\dagger A_n e^{\frac{2\pi i n}{L}} \\
 &= \sum_{n \in \mathcal{N}(n_0)} A_n^\dagger A_n \cos \frac{2\pi n}{L},
 \end{aligned} \tag{18.731}$$

$$\begin{aligned}
 \sum_{l=1}^L a_l a_{l+1}^\dagger &= \sum_{n', n'' \in \mathcal{N}(n_0)} A_{n''} A_{n'}^\dagger \frac{e^{-\frac{2\pi i n'}{L}}}{L} \sum_{l=1}^L e^{\frac{2\pi i(-n'+n'')l}{L}} \\
 &= \sum_{n \in \mathcal{N}(n_0)} A_n A_n^\dagger e^{-\frac{2\pi i n}{L}} \\
 &= \sum_{n \in \mathcal{N}(n_0)} A_n A_n^\dagger \cos \frac{2\pi n}{L},
 \end{aligned} \tag{18.732}$$

and

$$\begin{aligned}
 \sum_{l=1}^L a_l a_{l+1} &= e^{2i\varphi} \sum_{n', n'' \in \mathcal{N}(n_0)} A_{n''} A_{n'} \frac{e^{\frac{2\pi i n'}{L}}}{L} \sum_{l=1}^L e^{\frac{2\pi i(n'+n'')l}{L}} \\
 &= e^{2i\varphi} \sum_{n \in \mathcal{N}(n_0)} A_{-n} A_n e^{\frac{2\pi i n}{L}} \\
 &= i e^{2i\varphi} \sum_{n \in \mathcal{N}(n_0)} A_{-n} A_n \sin \frac{2\pi n}{L},
 \end{aligned} \tag{18.733}$$

and thus Eq. (18.460) holds.

h) The matrix M_n can be expressed as [see Eq. (18.463)]

$$M_n = \eta_n \begin{pmatrix} \cos(2\theta_n) & -ie^{-2i\varphi} \sin(2\theta_n) \\ ie^{2i\varphi} \sin(2\theta_n) & -\cos(2\theta_n) \end{pmatrix}, \quad (18.734)$$

where η_n and θ_n are given by Eqs. (18.466) and (18.469), respectively. The following holds [see Eqs. (6.301) and (6.302)]

$$U_n^{-1} M_n U_n = \eta_n \begin{pmatrix} 1 & 0 \\ 0 & -1 \end{pmatrix}, \quad (18.735)$$

where the unitary matrix U_n is given by Eq. (18.468), and thus

$$\Upsilon_n^\dagger M_n \Upsilon_n = \eta_n (b_n^\dagger \ b_{-n}) \begin{pmatrix} 1 & 0 \\ 0 & -1 \end{pmatrix} \begin{pmatrix} b_n \\ b_{-n}^\dagger \end{pmatrix}, \quad (18.736)$$

hence Eq. (18.465) holds.

i) The entropy Σ is given by [see Eqs. (18.470) and (16.287)]

$$\Sigma = - \sum_{n \in \mathcal{N}(n_0)} [\mu_n \log \mu_n + (1 - \mu_n) \log (1 - \mu_n)],$$

where

$$\mu_n = \frac{1}{e^{2\beta\eta_n} + 1}, \quad (18.737)$$

or [see Eqs. (18.464) and (18.466), recall that it is assumed that $L \gg 1$, and note that $\mu_{-n} = \mu_n$]

$$\Sigma = -\frac{L}{\pi} \int_0^\pi dk \left[\frac{1}{e^{2\beta\eta(k)} + 1} \log \frac{1}{e^{2\beta\eta(k)} + 1} + \frac{e^{2\beta\eta(k)}}{e^{2\beta\eta(k)} + 1} \log \frac{e^{2\beta\eta(k)}}{e^{2\beta\eta(k)} + 1} \right], \quad (18.738)$$

where $\eta^2(k) = (\Omega - J)^2 + 4\Omega J \sin^2(k/2)$. The identity

$$\frac{1}{e^{2q} + 1} \log \frac{1}{e^{2q} + 1} + \frac{e^{2q}}{e^{2q} + 1} \log \frac{e^{2q}}{e^{2q} + 1} = q \tanh q - \log(2 \cosh q), \quad (18.739)$$

leads to Eq. (18.472).

j) The following holds [see Eqs. (18.476) and (18.450)]

$$\begin{aligned} \langle \mathcal{H} \rangle &= -\Omega \sum_{l=1}^L \langle \sigma_{l,z} \rangle - J \sum_{l=1}^L \langle \sigma_{l,x} \rangle \langle \sigma_{l+1,x} \rangle \\ &= -L\Omega \left(\cos(\theta) + \frac{J}{\Omega} \sin^2(\theta) \cos^2(\phi) \right). \end{aligned} \quad (18.740)$$

For any given θ , the energy expectation value $\langle \mathcal{H} \rangle$ is minimized for $\phi = \phi_m = 0$. Using the relations

$$\frac{d}{d\theta} \left(\cos(\theta) + \frac{J}{\Omega} \sin^2(\theta) \right) = \left(\frac{2J}{\Omega} \cos(\theta) - 1 \right) \sin(\theta) , \quad (18.741)$$

$$\frac{d^2}{d\theta^2} \left(\cos(\theta) + \frac{J}{\Omega} \sin^2(\theta) \right) = -\cos(\theta) + \frac{2J}{\Omega} \cos(2\theta) , \quad (18.742)$$

one finds that

$$\theta_m = \begin{cases} 0 & \text{for } \frac{2J}{\Omega} < 1 \\ \cos^{-1} \left(\left(\frac{2J}{\Omega} \right)^{-1} \right) & \text{for } \frac{2J}{\Omega} \geq 1 \end{cases} , \quad (18.743)$$

and thus Eq. (18.477) holds [note that $\langle \sigma_x \rangle = \langle \psi(\theta, \phi = 0) | \sigma_x | \psi(\theta, \phi = 0) \rangle = \sin(\theta)$].

k) For a general $L = 2$ state

$$|\psi\rangle \doteq \begin{pmatrix} a \\ b \\ c \\ d \end{pmatrix} , \quad (18.744)$$

the following holds [compare with Eq. (17.185)]

$$\langle \sigma_{1,x} \rangle = \langle \psi | \begin{pmatrix} 0 & 0 & 1 & 0 \\ 0 & 0 & 0 & 1 \\ 1 & 0 & 0 & 0 \\ 0 & 1 & 0 & 0 \end{pmatrix} | \psi \rangle = ac^* + a^*c + bd^* + b^*d , \quad (18.745)$$

and

$$\langle \sigma_{2,x} \rangle = \langle \psi | \begin{pmatrix} 0 & 1 & 0 & 0 \\ 1 & 0 & 0 & 0 \\ 0 & 0 & 0 & 1 \\ 0 & 0 & 1 & 0 \end{pmatrix} | \psi \rangle = ab^* + a^*b + cd^* + c^*d , \quad (18.746)$$

As can be seen from Eq. (18.450), which for the case $L = 2$ becomes

$$\mathcal{H} \doteq \begin{pmatrix} -2\Omega & 0 & 0 & -J \\ 0 & 0 & -J & 0 \\ 0 & -J & 0 & 0 \\ -J & 0 & 0 & 2\Omega \end{pmatrix} , \quad (18.747)$$

$b = c = 0$ for two eigenvectors of \mathcal{H} , and $a = d = 0$ for the other two, and thus $\langle \sigma_{1,x} \rangle = \langle \sigma_{2,x} \rangle = 0$ for all energy eigenvectors of the Hamiltonian \mathcal{H} . For a general integer L , the same conclusion can be reached by noticing that the Hamiltonian \mathcal{H} (18.450) is invariant under the mirror reflection $x \rightarrow -x$.

26. The linear part \mathcal{H}_0 can be diagonalized using the $L \times L$ matrix u , which has entries given by

$$u_{l',l''} = \frac{\zeta_L^{l'l''}}{\sqrt{L}}, \quad (18.748)$$

where the complex number ζ_L is given by (note that $\zeta_L^L = 1$ and $|\zeta_L| = 1$)

$$\zeta_L = e^{-\frac{2\pi i}{L}}. \quad (18.749)$$

With the help of the identity [recall that $\sum_{l'=1}^L x^{l'} = x(1-x^L)/(1-x)$]

$$\begin{aligned} \frac{1}{L} \sum_{l'=1}^L \zeta_L^{ll'} &= \begin{cases} \frac{\zeta_L^l(1-\zeta_L^{lL})}{L(1-\zeta_L^l)} \text{ mod } (l, L) \neq 0 \\ 1 \text{ mod } (l, L) = 0 \end{cases} \\ &= \begin{cases} 0 \text{ mod } (l, L) \neq 0 \\ 1 \text{ mod } (l, L) = 0 \end{cases}, \end{aligned} \quad (18.750)$$

one finds that the matrix u is unitary, i.e.

$$u^\dagger u = uu^\dagger = 1, \quad (18.751)$$

and that the following holds

$$\begin{aligned} &u \begin{pmatrix} 0 & 1 & 0 & \vdots & 0 & 1 \\ 1 & 0 & 1 & \vdots & 0 & 0 \\ 0 & 1 & 0 & \vdots & 0 & 0 \\ \vdots & \vdots & \vdots & \ddots & \vdots & \vdots \\ 0 & 0 & 0 & \vdots & 0 & 1 \\ 1 & 0 & 0 & \vdots & 1 & 0 \end{pmatrix} u^\dagger \\ &= \begin{pmatrix} \zeta^1 + \zeta^{-1} & 0 & 0 & \vdots & 0 & 0 \\ 0 & \zeta^2 + \zeta^{-2} & 0 & \vdots & 0 & 0 \\ 0 & 0 & \zeta^3 + \zeta^{-3} & \vdots & 0 & 0 \\ \vdots & \vdots & \vdots & \ddots & \vdots & \vdots \\ 0 & 0 & 0 & \vdots & \zeta^{L-1} + \zeta^{-L+1} & 0 \\ 0 & 0 & 0 & \vdots & 0 & \zeta^L + \zeta^{-L} \end{pmatrix}. \end{aligned} \quad (18.752)$$

- a) The time evolution of $\langle n_\sigma \rangle$ depends on the commutation relation $[n_\sigma, \mathcal{H}]$ [see Eq. (4.38)]. With the help of the identity

$$[AB, C]_- = A[B, C]_+ - [A, C]_+ B, \quad (18.753)$$

one finds that [see Eqs. (16.8) and (16.9)]

$$\begin{aligned} & [n_\sigma, a_{l,\sigma}^\dagger a_{l+1,\sigma} + a_{l+1,\sigma}^\dagger a_{l,\sigma}] \\ &= [a_{l,\sigma}^\dagger a_{l,\sigma} + a_{l+1,\sigma}^\dagger a_{l+1,\sigma}, a_{l,\sigma}^\dagger a_{l+1,\sigma} + a_{l+1,\sigma}^\dagger a_{l,\sigma}] \\ &= a_{l,\sigma}^\dagger [a_{l,\sigma}^\dagger a_{l,\sigma}, a_{l+1,\sigma}] + [a_{l,\sigma}^\dagger a_{l,\sigma}, a_{l+1,\sigma}^\dagger] a_{l+1,\sigma} \\ &+ a_{l+1,\sigma}^\dagger [a_{l,\sigma}^\dagger a_{l,\sigma}, a_{l,\sigma}] + [a_{l,\sigma}^\dagger a_{l,\sigma}, a_{l+1,\sigma}^\dagger] a_{l,\sigma} \\ &+ a_{l,\sigma}^\dagger [a_{l+1,\sigma}^\dagger a_{l+1,\sigma}, a_{l+1,\sigma}] + [a_{l+1,\sigma}^\dagger a_{l+1,\sigma}, a_{l,\sigma}^\dagger] a_{l+1,\sigma} \\ &+ a_{l+1,\sigma}^\dagger [a_{l+1,\sigma}^\dagger a_{l+1,\sigma}, a_{l,\sigma}] + [a_{l+1,\sigma}^\dagger a_{l+1,\sigma}, a_{l+1,\sigma}^\dagger] a_{l,\sigma} \\ &= [a_{l,\sigma}^\dagger a_{l,\sigma}, a_{l+1,\sigma}^\dagger] a_{l+1,\sigma} + a_{l+1,\sigma}^\dagger [a_{l,\sigma}^\dagger a_{l,\sigma}, a_{l,\sigma}] \\ &+ a_{l,\sigma}^\dagger [a_{l+1,\sigma}^\dagger a_{l+1,\sigma}, a_{l+1,\sigma}] + [a_{l+1,\sigma}^\dagger a_{l+1,\sigma}, a_{l+1,\sigma}^\dagger] a_{l,\sigma} \\ &= a_{l,\sigma}^\dagger a_{l+1,\sigma} - a_{l+1,\sigma}^\dagger a_{l,\sigma} - a_{l,\sigma}^\dagger a_{l+1,\sigma} + a_{l+1,\sigma}^\dagger a_{l,\sigma} \\ &= 0. \end{aligned} \quad (18.754)$$

The above result, together with Eqs. (18.478), (18.479) and (16.11), imply that $[n_\sigma, \mathcal{H}] = 0$, thus n_σ is a constants of the motion.

- b) The relation (18.482) is obtained using Eq. (18.478).
 c) The following holds [see Eqs. (18.482) and (18.751)]

$$\mathcal{H}_0 = \sum_\sigma \mathcal{Y}_\sigma^\dagger M' \mathcal{Y}'_\sigma, \quad (18.755)$$

where $M' = u M u^\dagger$, $\mathcal{Y}'_\sigma = u \mathcal{Y}_\sigma$ and $\mathcal{Y}_\sigma^\dagger = \mathcal{Y}_\sigma^\dagger u^\dagger$, thus Eq. (18.486) holds [see Eqs. (18.485), (18.751) and (18.752)].

- d) The anti-commutation relations (16.8) and (16.9) for $b_{l,\sigma}^\dagger$ and $b_{l,\sigma}$ are obtained from the anti-commutation relations for $a_{l,\sigma}^\dagger$ and $a_{l,\sigma}$ together with Eq. (18.751).
 e) The following holds [see Eq. (18.488) and (18.489)]

$$\begin{aligned}
E(l_\sigma) &= -2 \sum_{l=0}^{l_\sigma} m + 2t \cos \frac{2\pi l}{L} \\
&= -2(l_\sigma + 1)m - 4t \operatorname{Re} \sum_{l=0}^{l_\sigma} e^{\frac{2\pi i l}{L}} \\
&= -2(l_\sigma + 1)m - 4t \operatorname{Re} \frac{e^{\frac{\pi i l_\sigma}{L}} \left(e^{\frac{\pi i (l_\sigma + 1)}{L}} - e^{-\frac{\pi i (l_\sigma + 1)}{L}} \right)}{\left(e^{\frac{\pi i}{L}} - e^{-\frac{\pi i}{L}} \right)} \\
&= -2(l_\sigma + 1)m - 4t \frac{\sin \left(\frac{\pi (l_\sigma + 1)}{L} \right)}{\sin \left(\frac{\pi}{L} \right)} \operatorname{Re} e^{\frac{\pi i l_\sigma}{L}} \\
&= -2(l_\sigma + 1)m - 4t \frac{\sin \left(\frac{\pi (l_\sigma + 1)}{L} \right) \cos \left(\frac{\pi l_\sigma}{L} \right)}{\sin \left(\frac{\pi}{L} \right)} \\
&\simeq -2l_\sigma m - 4t \frac{\sin \left(\frac{\pi l_\sigma}{L} \right) \cos \left(\frac{\pi l_\sigma}{L} \right)}{\frac{\pi}{L}},
\end{aligned} \tag{18.756}$$

thus Eq. (18.492) holds. The relation (18.495) is obtained using Eqs. (18.492) and (18.494). Alternatively, the definition given by Eq. (16.103) for the density of states per unit length

$$D(\eta_F) = \frac{1}{L} \sum_{l=-l_\sigma}^{l_\sigma} \delta(\eta_F - \eta_l), \tag{18.757}$$

yields for $L \gg 1$ [see Eq. (18.489)]

$$\begin{aligned}
D(\eta_F) &\simeq \frac{1}{L} \frac{L}{2\pi} \int dk \delta(\eta_F + m + 2t \cos k) \\
&= 2 \frac{1}{2\pi} \frac{1}{2|t \sin k|} \\
&= \frac{1}{\pi} \frac{1}{2|t| \sqrt{1 - \cos^2 k}} \\
&= \frac{1}{\pi \sqrt{4t^2 - (\eta_F + m)^2}},
\end{aligned} \tag{18.758}$$

in agreement with Eq. (18.495).

- f) The expression (18.496) for $\langle n_{l,\sigma} \rangle$ is obtained using Eqs. (16.155), (16.156) and (18.486).
g) With the help of Eqs. (18.490) and (18.750) one finds that

$$\begin{aligned}
 \sum_{l=1}^L n_{l,\uparrow} n_{l,\downarrow} &= \sum_{l=1}^L a_{l,\uparrow}^\dagger a_{l,\uparrow} a_{l,\downarrow}^\dagger a_{l,\downarrow} \\
 &= \sum_{l',l'',l''',l''''=1}^L b_{l''',\uparrow}^\dagger b_{l',\uparrow} b_{l''',\downarrow}^\dagger b_{l'',\downarrow} \sum_{l=1}^L \frac{e^{ik_l(l'+l''-l'''-l''')}}{L^2} \\
 &= \frac{1}{L} \sum_{l',l'',l''',l''''=1}^L b_{l''',\uparrow}^\dagger b_{l',\uparrow} b_{l''',\downarrow}^\dagger b_{l'',\downarrow} \delta_{l'+l''-l'''-l''''} .
 \end{aligned} \tag{18.759}$$

h) The mean field approximation energies η_l for spin state $\sigma \in \{\uparrow, \downarrow\}$ are given by [see Eqs. (18.488), (18.504) and (18.505)]

$$\eta_{l,\uparrow} = -m_\uparrow - 2t \cos k_l , \tag{18.760}$$

$$\eta_{l,\downarrow} = -m_\downarrow - 2t \cos k_l . \tag{18.761}$$

For given n_0 and m , the spin numbers l_\uparrow and l_\downarrow are given by

$$l_\uparrow = \frac{\langle n_{l,\uparrow} \rangle L}{2} = \frac{(n_0 + m) L}{2} , \tag{18.762}$$

$$l_\downarrow = \frac{\langle n_{l,\downarrow} \rangle L}{2} = \frac{(n_0 - m) L}{2} , \tag{18.763}$$

and thus the ground state energy E_0 is given by [see Eqs. (18.492), (18.504) and (18.505)]

$$\begin{aligned}
 E_0 &= -2l_\uparrow \left(m_\uparrow + 2t \frac{\sin \frac{2\pi l_\uparrow}{L}}{\frac{2\pi l_\uparrow}{L}} \right) - 2l_\downarrow \left(m_\downarrow + 2t \frac{\sin \frac{2\pi l_\downarrow}{L}}{\frac{2\pi l_\downarrow}{L}} \right) \\
 &= -(n_0 + m) L \left(m - U \left(n_0 - \frac{1}{2} - m \right) + 2t \frac{\sin \frac{\pi(n_0+m)L}{L}}{\frac{\pi(n_0+m)L}{L}} \right) \\
 &\quad - (n_0 - m) L \left(m - U \left(n_0 - \frac{1}{2} + m \right) + 2t \frac{\sin \frac{\pi(n_0-m)L}{L}}{\frac{\pi(n_0-m)L}{L}} \right) .
 \end{aligned} \tag{18.764}$$

The following holds

$$\left. \frac{d^2 E}{dm^2} \right|_{m=0} = 4L (\pi t \sin(n_0 \pi) - U) . \tag{18.765}$$

Note that $l_\uparrow = l_\downarrow = n_0 L/2$ for $m = 0$ [see Eqs. (18.762) and (18.763)]. The Stoner criterion (18.507) is derived from the condition $d^2 E/dm^2 < 0$ at $m = 0$ using Eq. (18.495).

27. Recall that the commutation relation (18.514) implies that the eigenvalues of the number operator $B^\dagger B$ are the non-negative integers (see chapter 5).

a) By assuming that the commutation relation (18.514) holds one finds that [see Eqs. (18.511), (18.512) and (18.513)]

$$\begin{aligned} [\Sigma_z, \Sigma_+] &= 2 [B^\dagger B, B^\dagger] (\mathcal{N} - B^\dagger B)^{1/2} \\ &= 2B^\dagger (\mathcal{N} - B^\dagger B)^{1/2} \\ &= 2\Sigma_+ , \end{aligned} \tag{18.766}$$

$$\begin{aligned} [\Sigma_z, \Sigma_-] &= 2 (\mathcal{N} - B^\dagger B)^{1/2} [B^\dagger B, B] \\ &= -2 (\mathcal{N} - B^\dagger B)^{1/2} B \\ &= -2\Sigma_- , \end{aligned} \tag{18.767}$$

and

$$\begin{aligned} &[\Sigma_+, \Sigma_-] \\ &= B^\dagger (\mathcal{N} - B^\dagger B) B - (\mathcal{N} - B^\dagger B)^{1/2} B B^\dagger (\mathcal{N} - B^\dagger B)^{1/2} \\ &= B^\dagger (\mathcal{N} - ([B^\dagger, B] + B B^\dagger)) B - (\mathcal{N} - B^\dagger B)^{1/2} ([B, B^\dagger] + B^\dagger B) (\mathcal{N} - B^\dagger B)^{1/2} \\ &= -\mathcal{N} + 2B^\dagger B \\ &= \Sigma_z , \end{aligned} \tag{18.768}$$

thus the commutation relations (18.191), (18.192) and (18.193) hold.

b) Note that the commutation relations (18.190) and (18.514) imply that the operators a and b satisfy the same relations [see Eqs. (18.515) and (18.516)]

$$[a, a^\dagger] = 1 , \tag{18.769}$$

$$[b, b^\dagger] = 1 . \tag{18.770}$$

In terms of the operators a and b the Hamiltonian (18.508) is given by [see Eqs. (18.511), (18.512), (18.513), (18.515) and (18.516)]

$$\begin{aligned} \hbar^{-1} \mathcal{H}_D &= \omega_e \left[(\alpha^* + a^\dagger) (\alpha + a) + \frac{1}{2} \right] \\ &\quad + \frac{\omega_a}{2} [-\mathcal{N} + 2 (\beta^* + b^\dagger) (\beta + b)] \\ &\quad + g_s [(\alpha^* + a^\dagger) J_D (\beta + b) + (\alpha + a) (\beta^* + b^\dagger) J_D] , \end{aligned} \tag{18.771}$$

where J_D is given by

$$J_D = [\mathcal{N} - (\beta^* + b^\dagger) (\beta + b)]^{1/2} . \tag{18.772}$$

c) For this case the Hamiltonian (18.771) becomes

$$\hbar^{-1}\mathcal{H}_D = \omega_e a^\dagger a + \omega_a b^\dagger b + g_{\text{eff}} (a^\dagger b + ab^\dagger) + \frac{\omega_e}{2} - \frac{\mathcal{N}\omega_a}{2}, \quad (18.773)$$

where

$$g_{\text{eff}} = N^{1/2} g_s, \quad (18.774)$$

or in a matrix form

$$\begin{aligned} \hbar^{-1}\mathcal{H}_D &= (a^\dagger \ b^\dagger) M \begin{pmatrix} a \\ b \end{pmatrix} \\ &+ \frac{\omega_e}{2} - \frac{\mathcal{N}\omega_a}{2}, \end{aligned} \quad (18.775)$$

where the 2×2 matrix M is given by

$$M = \begin{pmatrix} \omega_e & g_{\text{eff}} \\ g_{\text{eff}} & \omega_a \end{pmatrix}. \quad (18.776)$$

Thus in this approximation the energy eigenvalues of the Hamiltonian \mathcal{H}_D are given by [compare with Eq. (9.211)]

$$E_{n_+, n_-} = \hbar \left(n_+ \omega_+ + n_- \omega_- + \frac{\omega_e}{2} - \frac{\mathcal{N}\omega_a}{2} \right), \quad (18.777)$$

where both n_+ and n_- are non-negative integers, and where the angular frequencies ω_\pm , which are given by

$$\omega_\pm = \frac{\omega_a + \omega_e}{2} \pm \frac{1}{2} \sqrt{(\omega_e - \omega_a)^2 + 4g_{\text{eff}}^2}, \quad (18.778)$$

are the eigenvalues of the matrix M . As can be seen from the above result (18.778), both angular frequencies ω_\pm are positive provided that

$$g_{\text{eff}} < \sqrt{\omega_a \omega_e}. \quad (18.779)$$

References

1. Claude Cohen-Tannoudji, Bernard Diu, Franck Laloe, Quantum Mechanics, Wiley, New York (1977).
2. J.J.Sakurai, Modern Quantum Mechanics, Addison-Wesley, New York (1994).
3. L. D. Landau and L. M. Lifshitz, Quantum Mechanics Non-Relativistic Theory, Oxford: Pergamon Press (1977).
4. L. S. Schulman, Techniques and Applications of Path Integration, , Wiley, New York (1981).
5. M. V. Berry, Quantal phase-factors accompanying adiabatic changes, Proc. Roy. Soc. London A **392**, 45-57 (1984).
6. Alexander L. Fetter and John Dirk Walecka, Quantum Theory of Many-Particle Systems, Mcgraw-Hill (1971).
7. Howard Carmichael, An open systems approach to quantum optics, Springer (August 1993).

Index

- action, 3
- adiabatic approximation, 567
- Aharonov-Bohm effect, 540
- angular momentum, 179

- birefringence, 602
- Bloch-Siegert shift, 781
- Bogoliubov transformation, 666, 799
- Bohr's magneton, 34, 82
- Bohr's radius, 274
- Bohr-Sommerfeld quantization rule, 516
- Bose-Einstein function, 674
- Boson, 648, 650
- bra-vector, 21

- canonically conjugate, 7
- cavity quantum electrodynamics, 778
- central potential, 267
- chemical potential, 380
- closure relation, 22
- coherence length, 807
- collapse postulate, 33
- commutation relation, 39
- commuting operators, 40
- conductivity, 792
- conservative system, 6
- continuity equation, 511
- Coulomb gauge, 591, 625
- current density, 511

- DC SQUID, 786
- degeneracy, 28
- density operator, 297
- Dicke model, 831
- dielectric function, 789
- diffraction, 607
- Dirac's notation, 21
- Drude model, 791
- dual correspondence, 23

- Ehrenfest's theorem, 87

- eigenvalue, 27
- eigenvector, 27
- equipartition theorem, 700
- Euler-Lagrange equations, 4
- expectation value, 33

- Fermi's golden rule, 486
- Fermi-Dirac function, 673
- Fermion, 648
- Feynman's path integral, 539
- fine-structure constant, 628
- flux quantum, 543, 762, 814
- fugacity, 381

- gauge invariance, 543, 758
- gauge transformation, 569
- generalized force, 6
- geometrical phase, 568
- gyromagnetic ratio, 34

- Hamilton's formalism, 3
- Hamilton-Jacobi equations, 7
- Heisenberg representation, 83
- Hermitian adjoint, 26
- Holstein-Primakoff transformation, 831
- Hydrogen atom, 272

- ideal gas, 666
- identical particles, 647
- inner product, 19

- Jaynes-Cummings Hamiltonian, 780
- Jaynes-Cummings model, 432
- Josephson effect, 763
- Josephson inductance, 765

- ket-vector, 21
- kinetic energy, 6

- Lagrangian, 3
- Larmor frequency, 82
- linear vector space, 19

- London Equations, 759
- London penetration depth, 760

- macroscopic quantum model, 759
- magnetic moment, 33
- matrix representation, 24
- Maxwell's equations, 591, 789
- Meissner effect, 760
- momentum representation, 62
- momentum wavefunction, 63

- norm, 20
- normal ordering, 140
- number density operator, 655
- number operator, 128

- observable, 26
- operator, 21
- optical Bloch equations, 709
- orbital angular momentum, 179, 187
- orthogonal, 20
- orthonormal basis, 20
- outer product, 22

- parity operator, 607
- path integration, 535
- Pauli's exclusion principle, 651
- Planck's constant, 1
- plasma frequency, 768, 792
- Poincaré sphere, 600
- Poisson's brackets, 9
- polarization, 599
- position representation, 58
- position wavefunction, 59
- positive-definite, 43
- potential energy, 6
- Poynting vector, 631
- principle of least action, 4
- projector, 29
- Purcell effect, 784
- pure ensemble, 299

- quantized field operator, 654
- quantum bit, 776
- quantum measurement, 32
- quantum statistical mechanics, 300

- Rabi frequency, 224
- radial equation, 270
- Rayleigh-Sommerfeld, 618
- reduced mass, 272
- rotation, 180

- scattering time, 791
- Schrödinger equation, 1, 79
- Schwartz inequality, 41, 42
- second quantization, 659
- semiclassical limit, 553
- Shapiro steps, 821
- shell, 277
- spherical harmonics, 191
- spin, 33
- spin 1/2, 81, 187
- SQUID, 766
- state vector, 19
- stationary state, 81
- Stern-Gerlach, 34
- superconductivity, 757
- symmetric ordering, 84

- thermal bath, 694
- thermal equilibrium, 698
- Thomas-Fermi approximation, 793
- Thomas-Reiche-Kuhn sum rule, 90
- time evolution operator, 79
- time-dependent perturbation theory, 479
- tomography, 309
- trace, 38
- transformation function, 63
- translation operator, 58
- tunneling, 518
- turning point, 512
- two-mode squeezing, 722

- uncertainty principle, 41, 307
- unitary, 37
- Unruh-Davies effect, 716

- vector potential, 591, 625

- Weyl transformation, 85
- Weyl's expansion, 618
- WKB approximation, 509